

SITE PLAN  
1"=8'

ALL DIMENTION ARE IN INTCH/FIT.  
SCALE-1"=8'

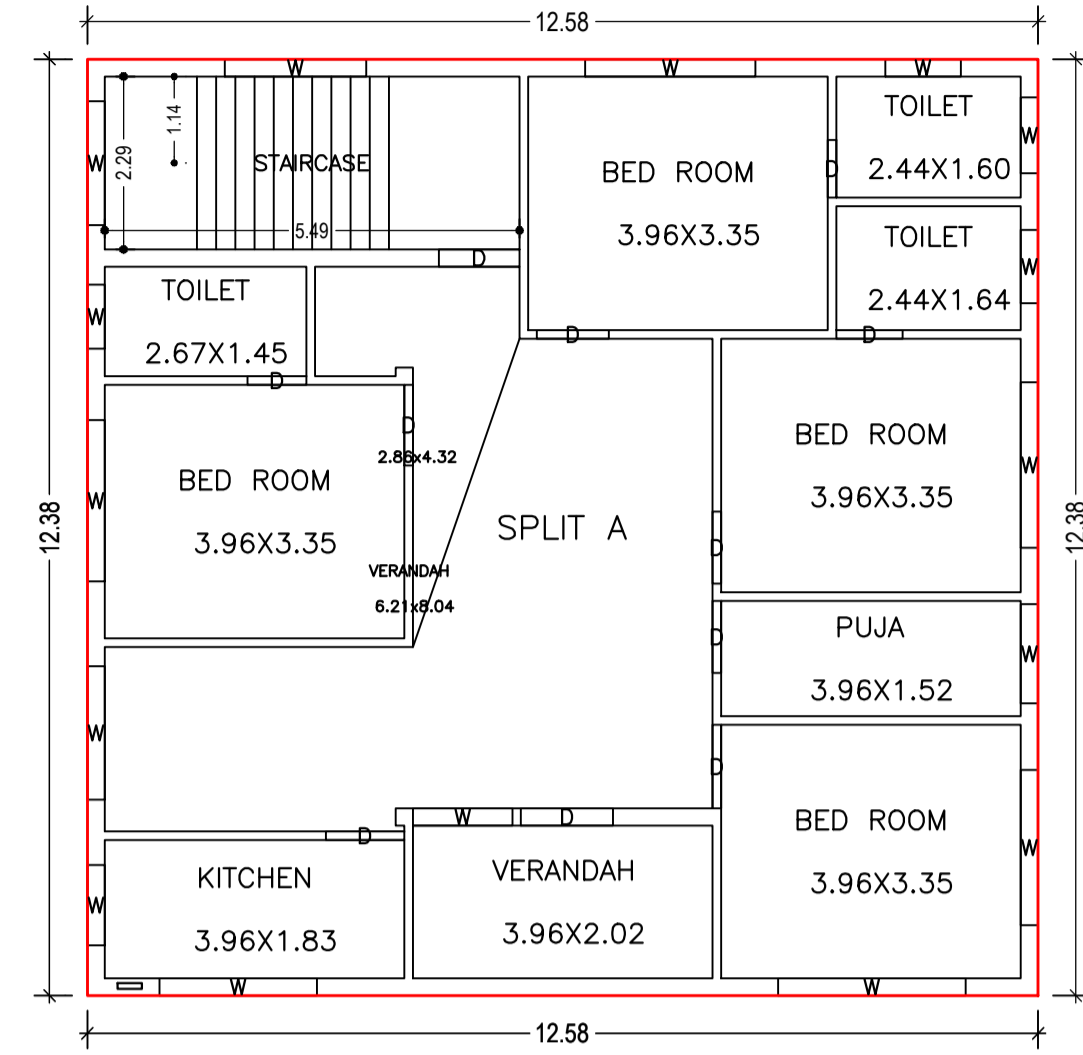

GROUND FLOOR PLAN  
(Proposed)  
(SCALE 1:100)

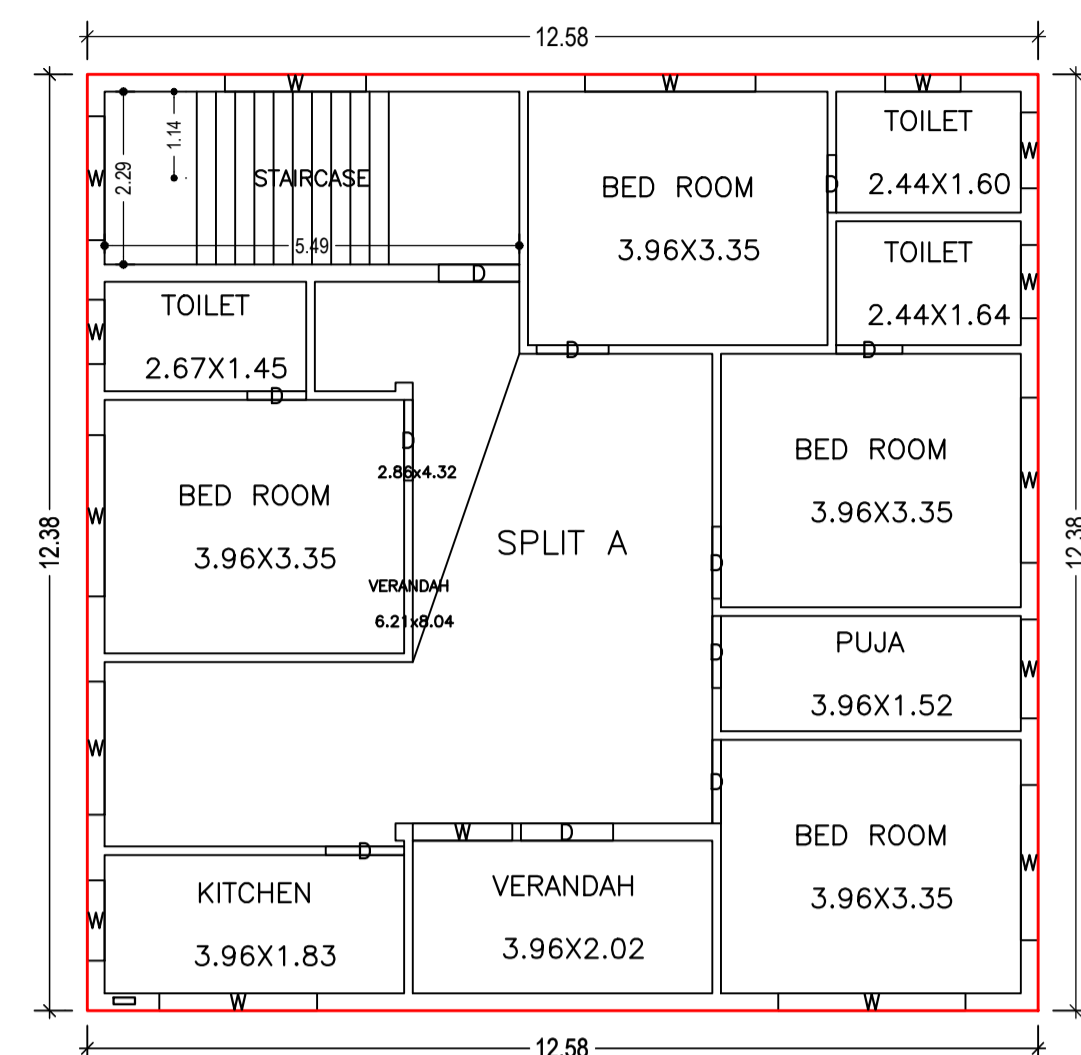

FIRST FLOOR PLAN  
(Proposed)  
(SCALE 1:100)

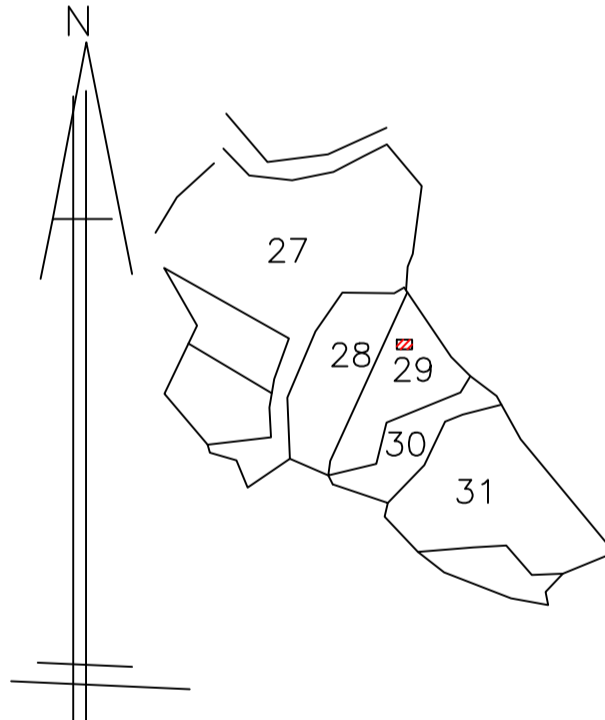

KEY PLAN  
1"=330'

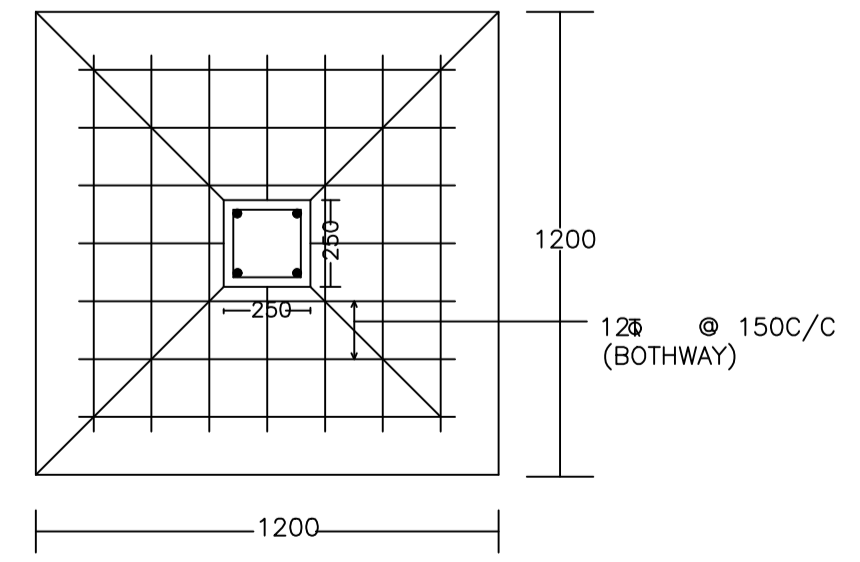
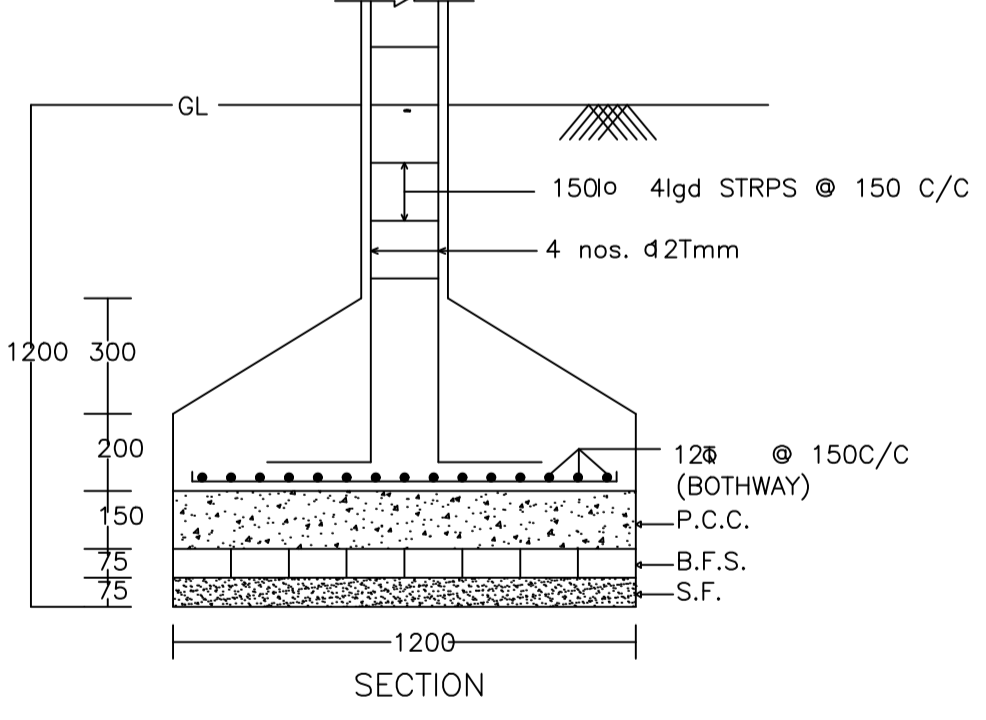
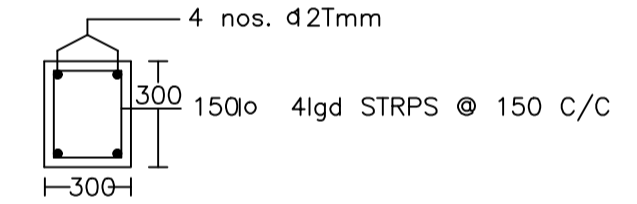

DETAIL OF COLUMNS PLOT NO. 28

UnitBUA Table for Building :A (SMT GAYATRI DEVI)

FLOOR	Name	UnitBUA Type	UnitBUA Area	Carpet Area	No. of Rooms	No. of Tenement
GROUND FLOOR PLAN	SPLIT A	FLAT	311.49	311.44	11	1
FIRST FLOOR PLAN	SPLIT A	FLAT	0.00	0.00	11	0
Total:	-	-	311.49	311.44	22	1

Building :A (SMT GAYATRI DEVI)

Floor Name	Total Built Up Area (Sq.mt.)	Proposed FAR Area (Sq.mt.) Resi.	Total FAR Area (Sq.mt.)	Total Consumed Additional FAR Area (Sq.mt.)	Tnmt (No.)
Ground Floor	155.74	155.74	155.74	155.74	01
First Floor	155.74	155.74	155.74	155.74	00
Terrace Floor	0.00	0.00	0.00	0.00	00
Total	311.48	311.48	311.48	311.48	01
Total Number of Same Buildings	1				
Total:	311.48	311.48	311.48	311.48	01

SCHEDULE OF DOOR:

BUILDING NAME	NAME	LENGTH	HEIGHT	NOS
A (SMT GAYATRI DEVI)	D	0.76	2.10	02
A (SMT GAYATRI DEVI)	D	0.78	2.10	02
A (SMT GAYATRI DEVI)	D	0.88	2.10	02
A (SMT GAYATRI DEVI)	D	0.95	2.10	06
A (SMT GAYATRI DEVI)	D	1.04	2.10	02
A (SMT GAYATRI DEVI)	D	1.07	2.10	04
A (SMT GAYATRI DEVI)	D	1.11	2.10	02
A (SMT GAYATRI DEVI)	D	1.22	2.10	02

SCHEDULE OF WINDOW/VENTILATION:

BUILDING NAME	NAME	LENGTH	HEIGHT	NOS
A (SMT GAYATRI DEVI)	W	0.85	1.20	02
A (SMT GAYATRI DEVI)	W	0.97	1.20	02
A (SMT GAYATRI DEVI)	W	1.00	1.20	04
A (SMT GAYATRI DEVI)	W	1.06	1.20	02
A (SMT GAYATRI DEVI)	W	1.31	1.20	02
A (SMT GAYATRI DEVI)	W	1.32	1.20	02
A (SMT GAYATRI DEVI)	W	1.64	1.20	02
A (SMT GAYATRI DEVI)	W	1.76	1.20	02
A (SMT GAYATRI DEVI)	W	1.87	1.20	02
A (SMT GAYATRI DEVI)	W	2.05	1.20	02
A (SMT GAYATRI DEVI)	W	2.09	1.20	02
A (SMT GAYATRI DEVI)	W	2.13	1.20	02
A (SMT GAYATRI DEVI)	W	2.19	1.20	02
A (SMT GAYATRI DEVI)	W	2.25	1.20	02
A (SMT GAYATRI DEVI)	W	2.48	1.20	02

Proposal Basic Information

Proposal File No.	DMC/BP/0036/W23/2022
Owner Name	GAYATRI DEVI
Khata No	OLD- 22, NEW- 12
Plot No	OLD- 29, NEW- 29
Village Name	Amaghata
Use	Residential
SubUse	Bungalow/ Dwelling / Non Apartment

AREA STATEMENT

AREA OF PLOT (Minimum)	(A)	SQ.MT.
NET AREA OF PLOT(Gross Plot Area - Deduction from Gross Plot area)	(A-Deductions)	409.04
Deduction for Balance Plot Area(from Gross Plot Area)		
Common Plot		101.34
Total		101.34
BALANCE AREA OF PLOT(Net Plot Area - Recreational/Amenity space)	(A-Deductions)	307.69
PLOT AREA FOR COVERAGE(Net Plot Area)	(A-Deductions)	409.04
Plot Area for FAR (Net Plot Area + RoadWidening Area)	(A-Deductions)	409.04
COVERAGE CHECK		
Permissible Coverage area ( 60.00 % )		245.42
Proposed Coverage Area ( 38.07 % )		155.74
Total Prop. Coverage Area ( 38.07 % )		155.74
Balance coverage area ( 21.92 % )		89.68
FAR CHECK		
Perm. FAR Area ( 1.50 )		613.56
Total Perm. FAR area		613.56
Residential FAR		311.49
Proposed FAR Area		311.49
Total Proposed FAR Area		311.49
Consumed FAR (Factor)		0.76
Balance FAR Area		302.07
BUILT UP AREA CHECK		
Total Proposed BuiltUp Area		311.48
ARCHITECT (Regd)		RAJEEV RANJAN SINGH
ENGINEER (Regd)		
SUPERVISOR (Regd)		
OWNER (Regd)		GAYATRI DEVI
DEVELOPMENT AUTHORITY		LOCAL BODY

COLOR INDEX

PLOT BOUNDARY	Black
ABUTTING ROAD	Green
PROPOSED CONSTRUCTION	Red
COMMON PLOT	Yellow
ROAD WIDENING AREA	Blue
EXISTING (To be retained)	Light Blue
EXISTING (To be demolished)	Orange

Buildingwise Floor FAR Details

Floor Name	Building Name		Total	
	Proposed Built Up Area (Sq.mt.)	Proposed FAR Area (Sq.mt.)	Total Proposed Built Up Area (Sq.mt.)	Total FAR Area (Sq.mt.)
Ground Floor	155.74	155.74	155.74	155.74
First Floor	155.74	155.74	155.74	155.74
Terrace Floor	0.00	0.00	0.00	0.00
Total:	311.48	311.48	311.48	311.48

Building USE/SUBUSE Details

Building Name	Building Use	Building SubUse	Building Structure
A (SMT GAYATRI DEVI)	Residential	Residential Bldg/Apartment	Non-Highrise

FAR & Tenement Details (Table 4c-1)

Building	No. of Same Bldg	Total Built Up Area (Sq.mt.)	Proposed FAR Area (Sq.mt.) Resi.	Total FAR Area (Sq.mt.)	Total Consumed Additional FAR Area (Sq.mt.)	Tnmt (No.)
A (SMT GAYATRI DEVI)	1	311.48	311.48	311.48	311.48	01
Grand Total :	1	311.48	311.48	311.48	311.48	01

LTP NAME AND SIGNATURE	STRUCTURAL ENG'S NAME AND SIGNATURE	BUILDER NAME AND SIGNATURE	DIGITAL SIGNATURE
RAJEEV RANJAN SINGH DMC/ENG/0032/2017			

Proposal Basic Information

Proposal File No.	DMC/BP/0036/W23/2022
Owner Name	GAYATRI DEVI
Khata No	OLD- 22, NEW- 12
Plot No	OLD- 29, NEW- 29
Village Name	Amaghata
Use	Residential
SubUse	Bungalow/ Dwelling / Non Apartment

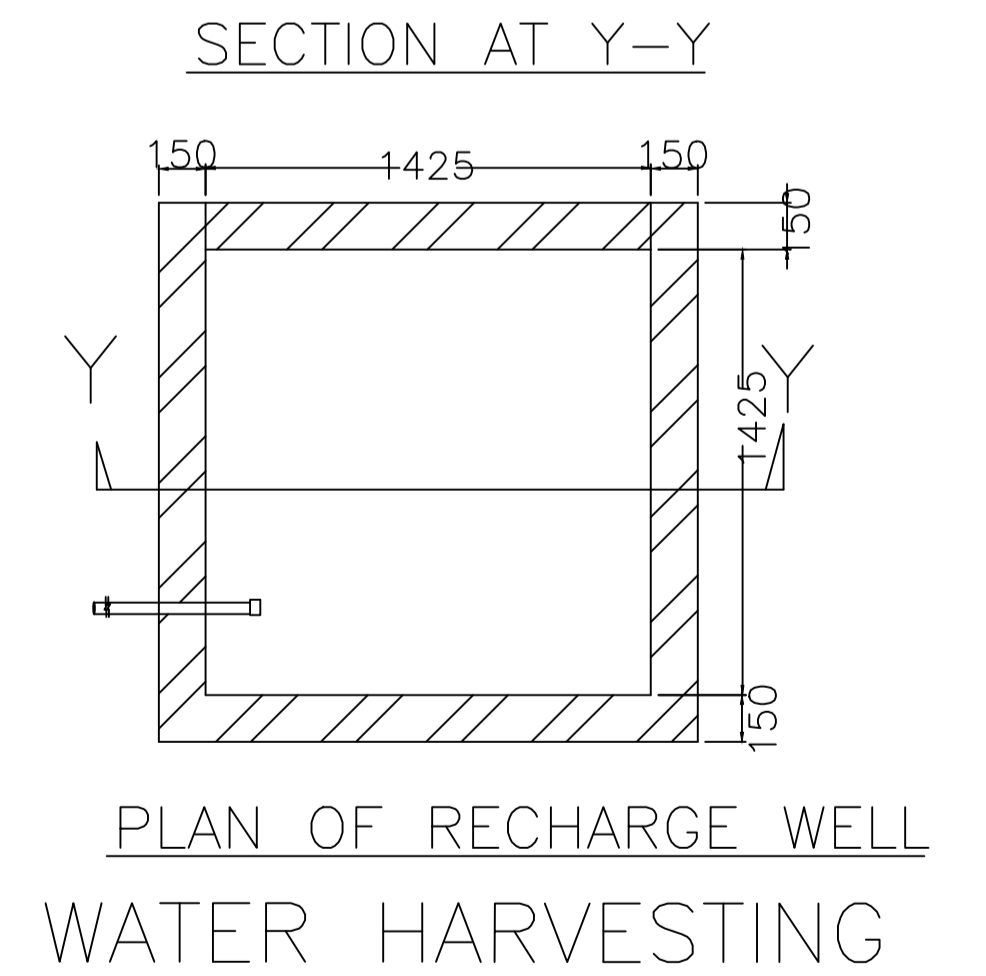
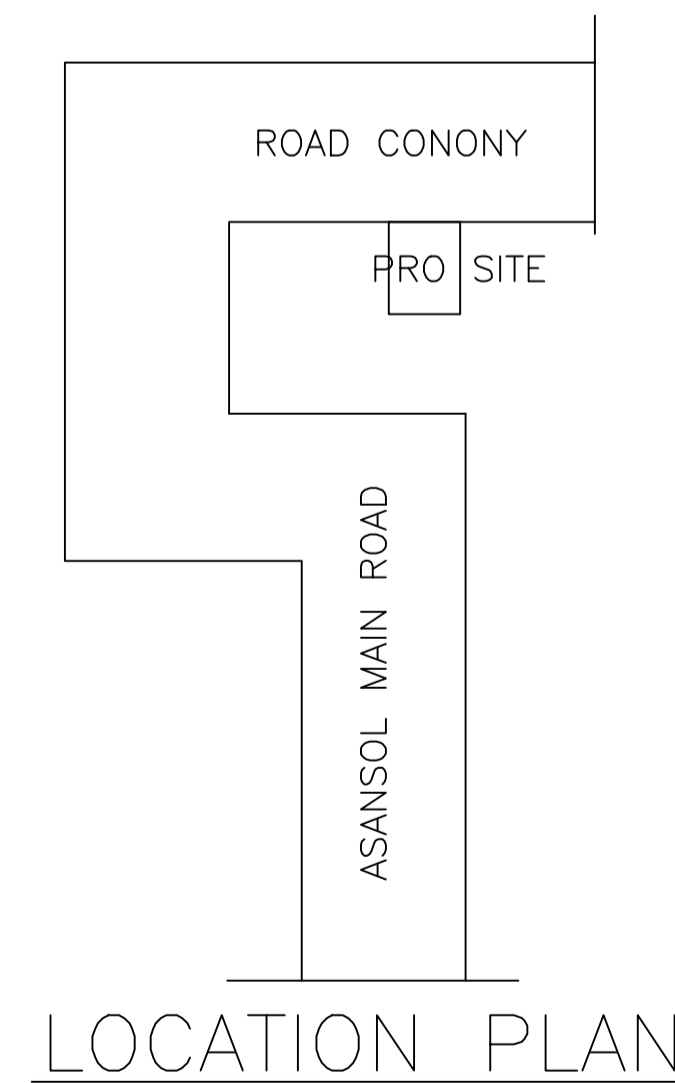
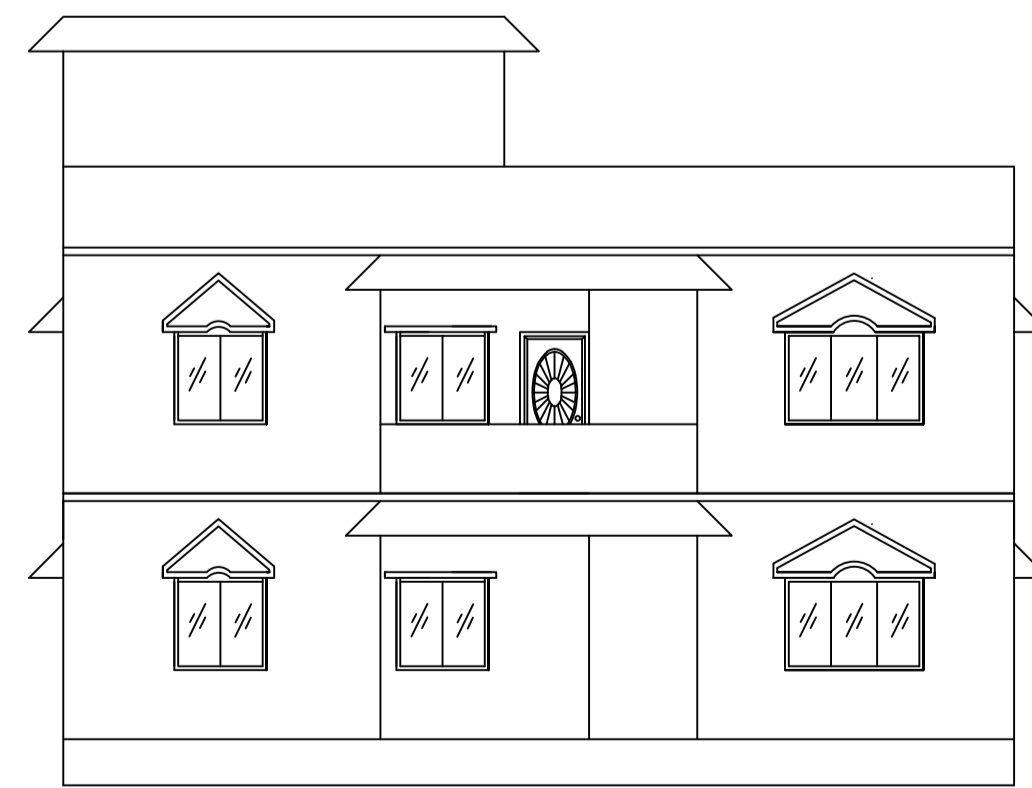
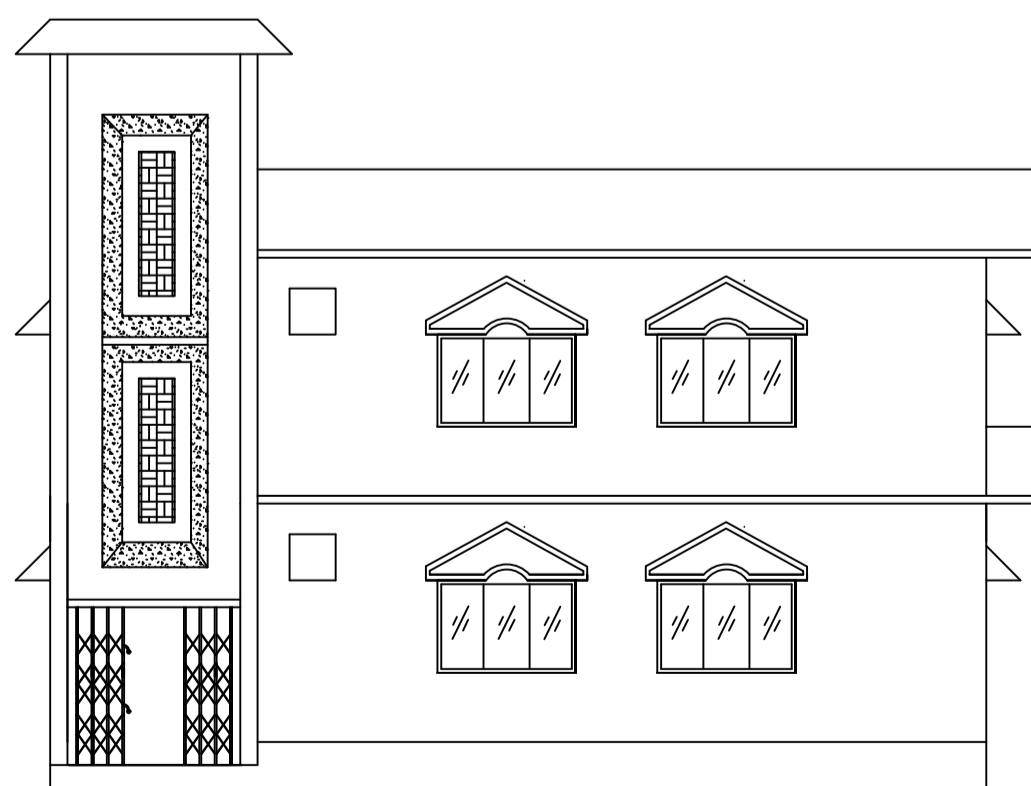
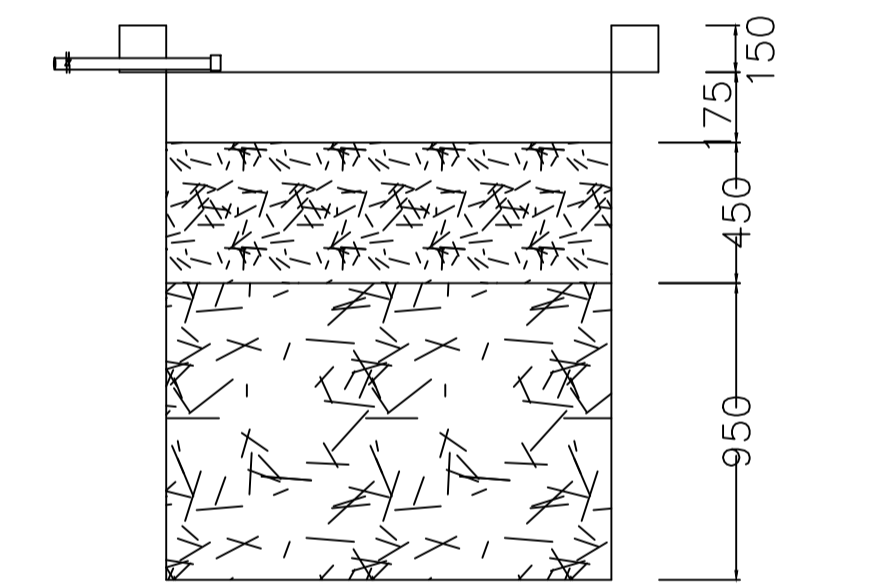
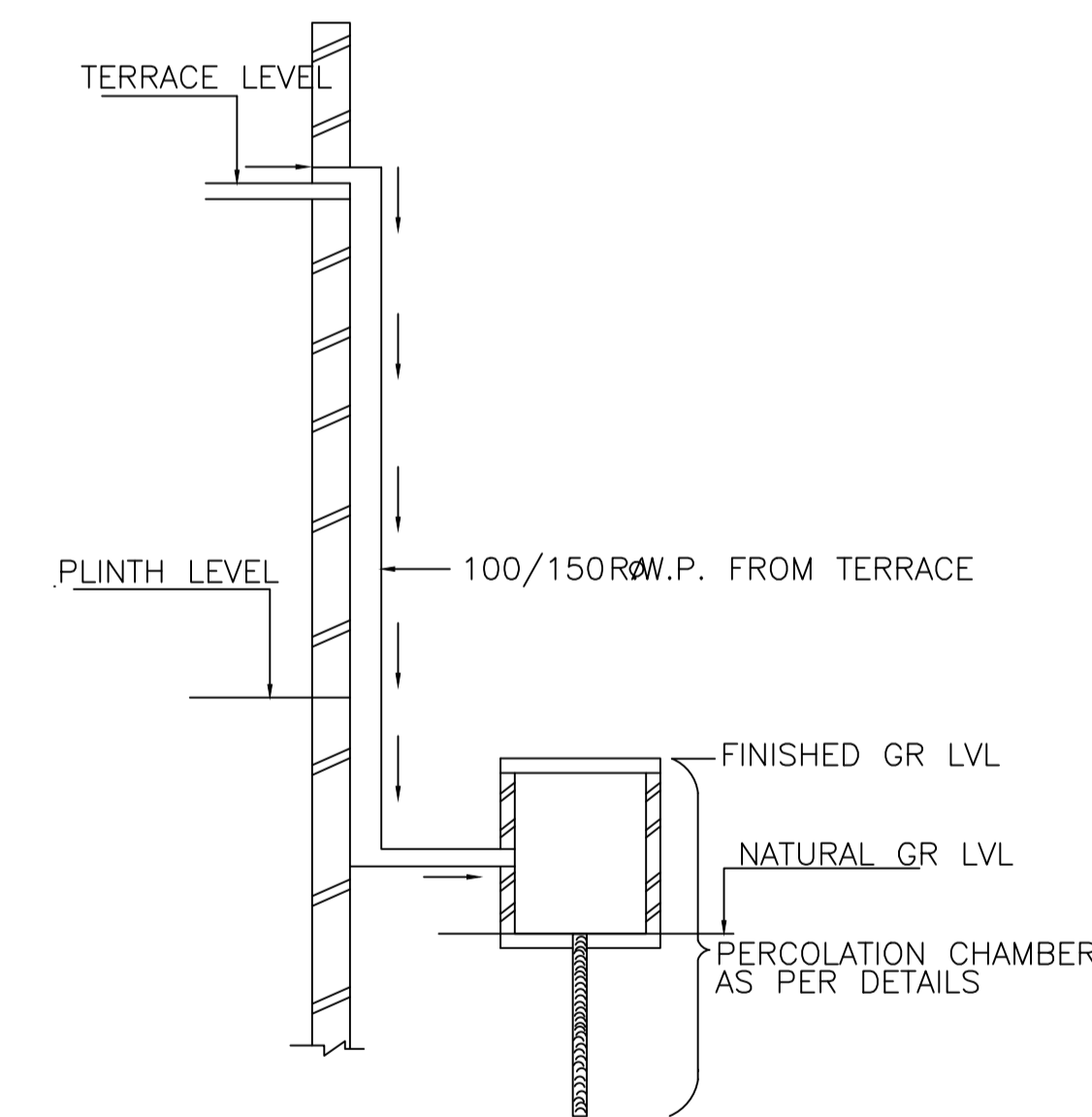
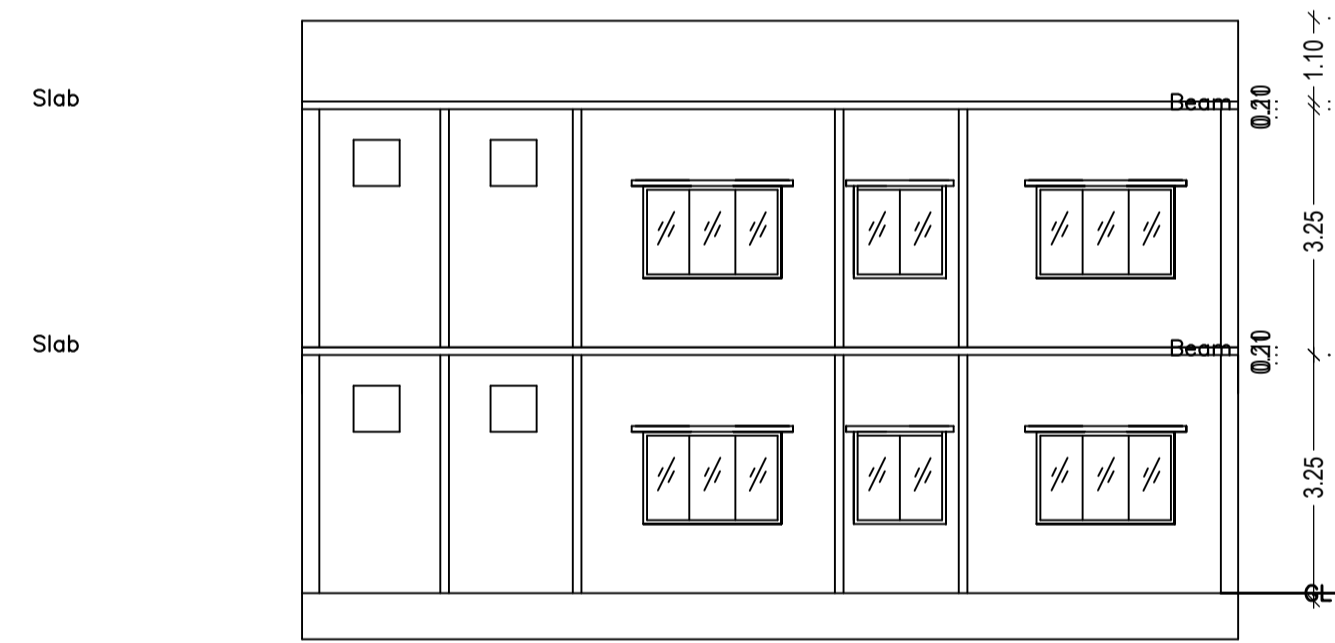
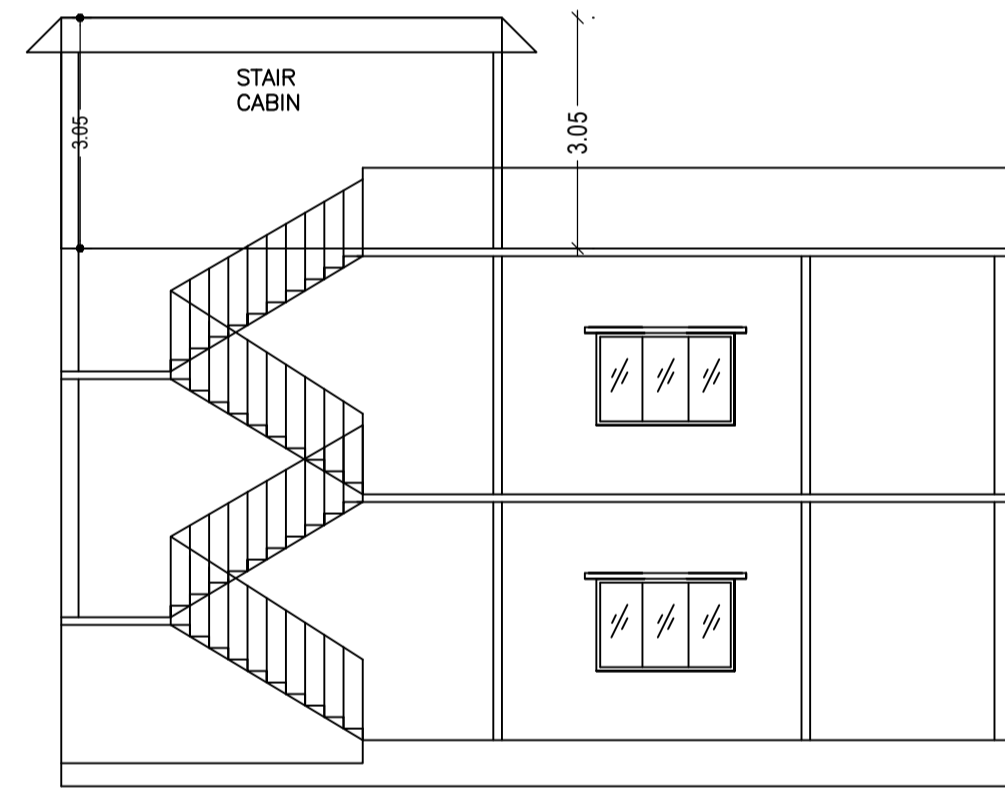
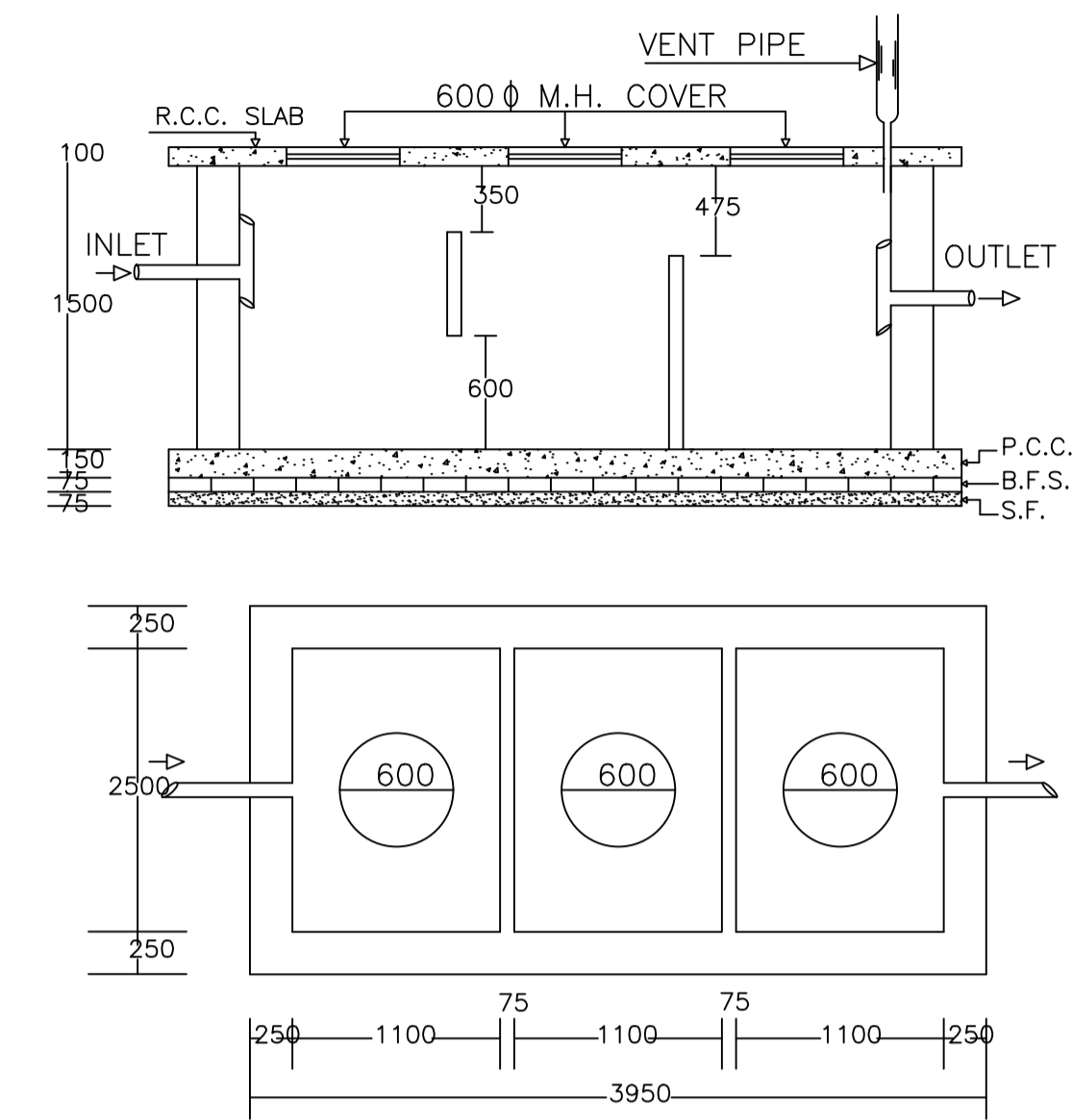
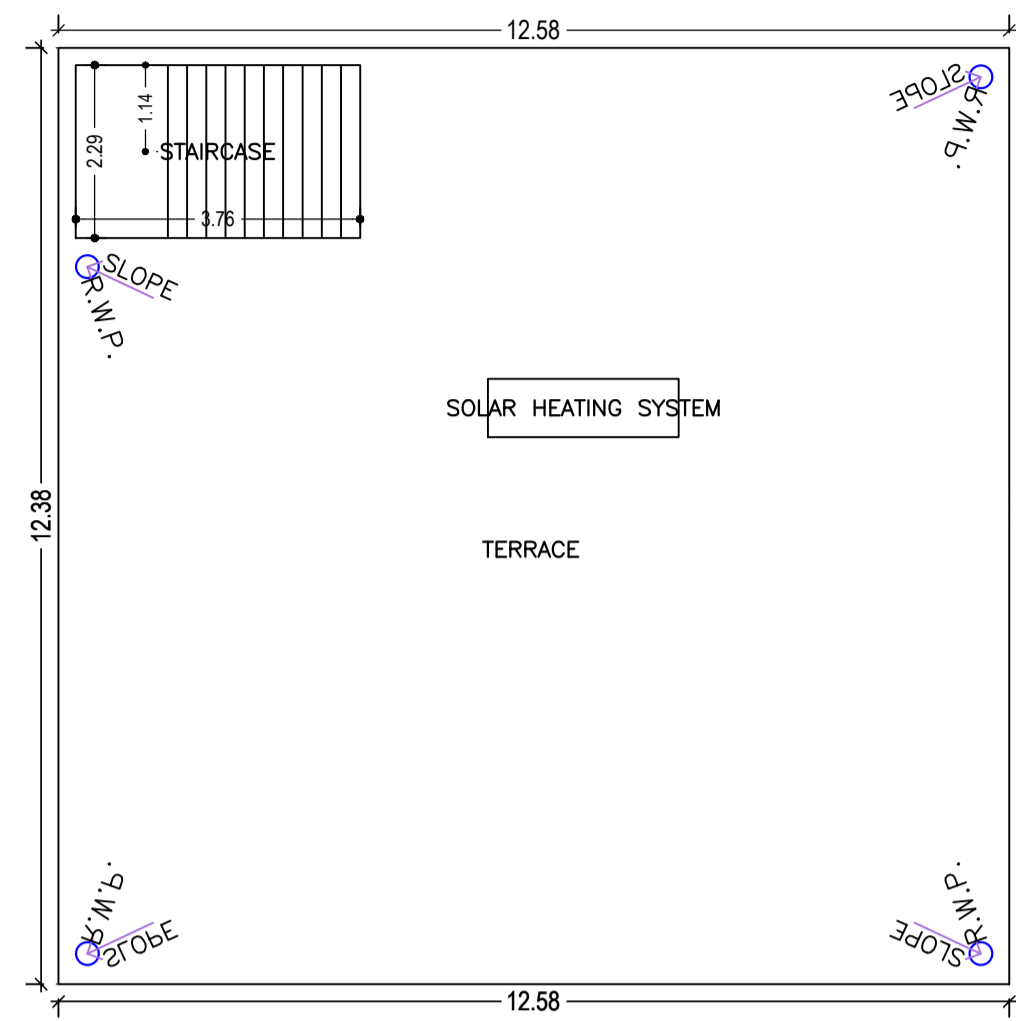
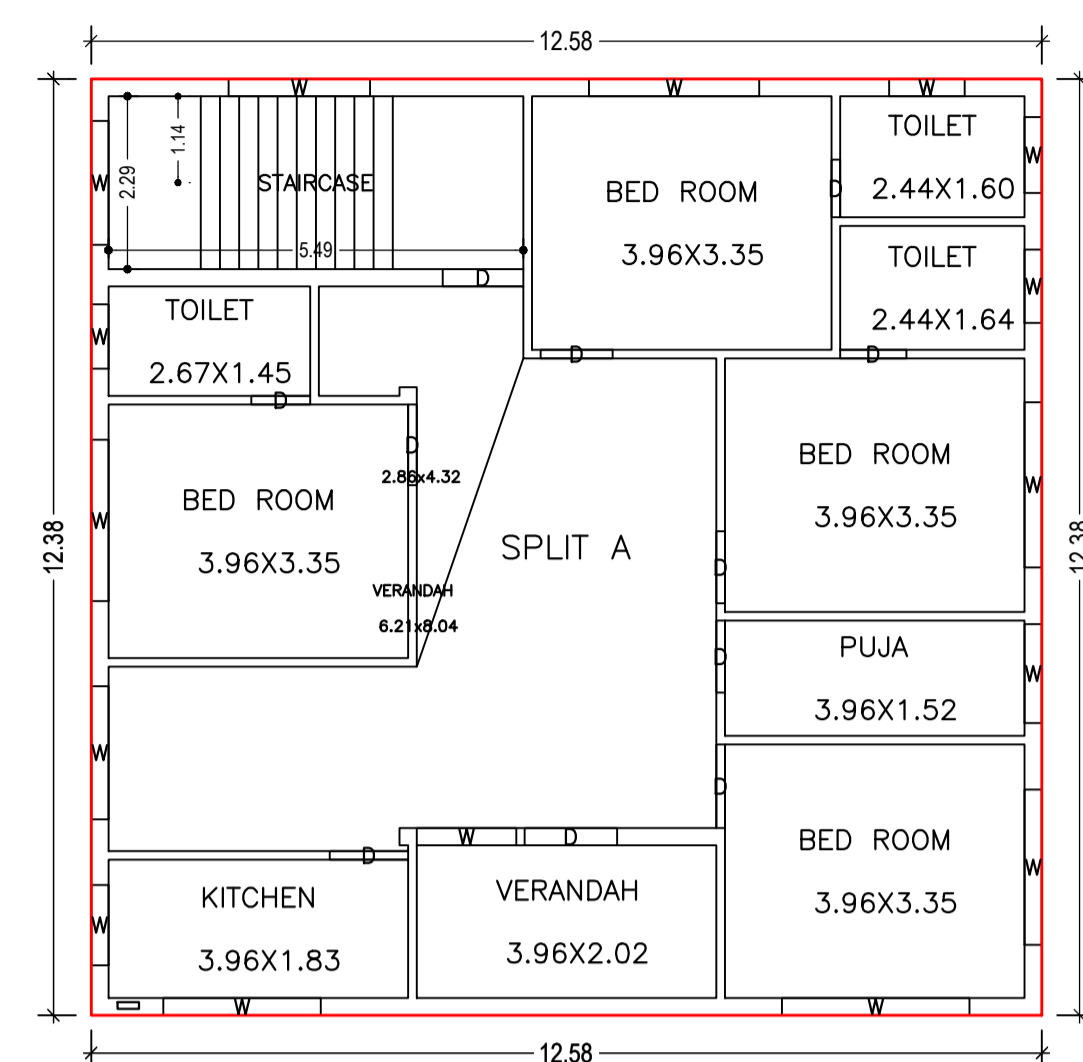
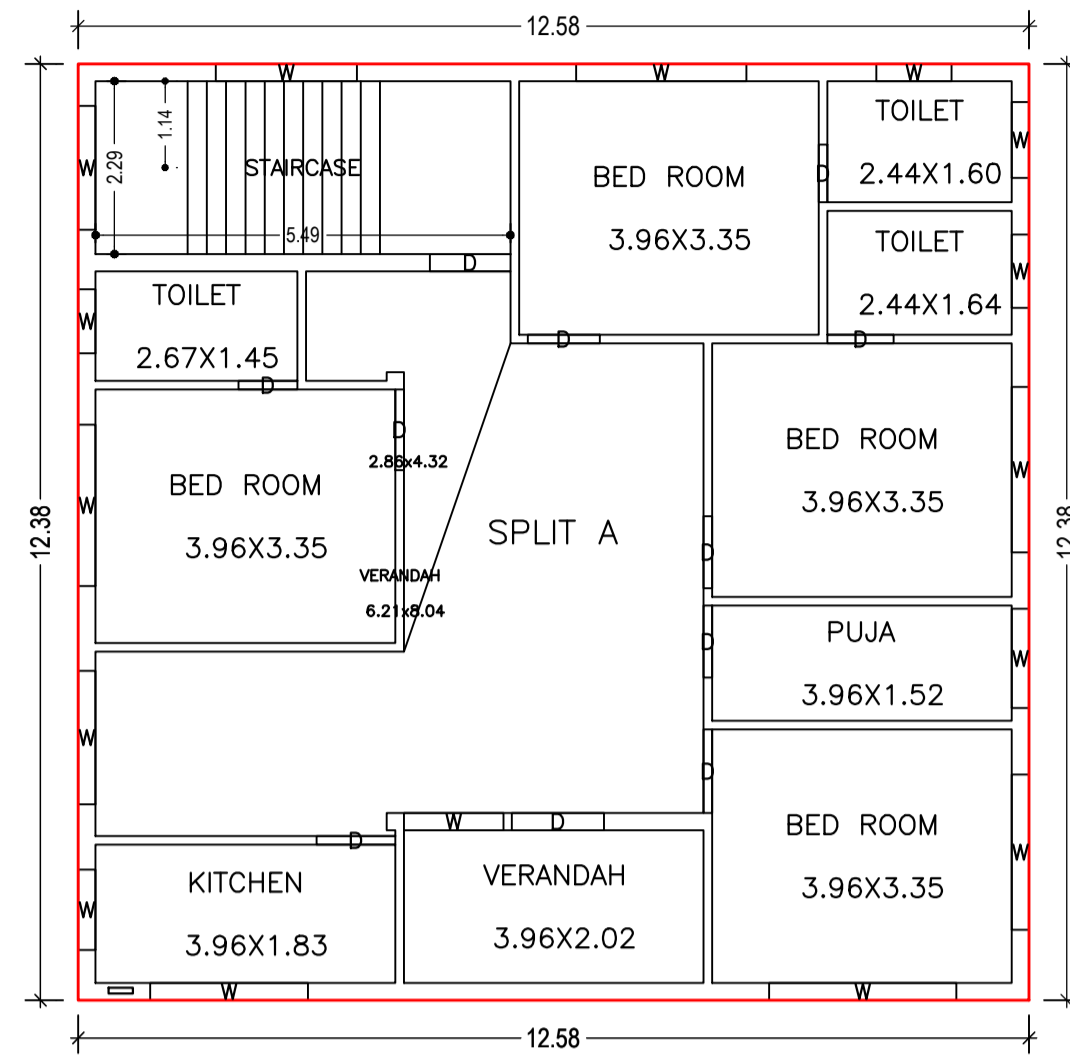

LTP NAME AND SIGNATURE RAJEEV RANJAN SINGH DMC/ENG/0032/2017	STRUCTURAL ENG'S NAME AND SIGNATURE	BUILDER NAME AND SIGNATURE	DIGITAL SIGNATURE
--	-------------------------------------	----------------------------	-------------------