

Project Title :1) IBRAR AHMAD 2) MINOR ADIL AHMAD

AREA STATEMENT (WARD MUNICIPAL CORPORATION)	VERSION NO. 1.0.36
PROJECT TITLE	VERSION DATE: 18/10/2020
Plot No. Residential	Plot Use: Residential
Project: PANDARPALA URBAN LOCAL BODIES	Plot Location: Bangalore Dwelling / Non Apartment
Project Type: Building Permission	Level Use: NA
Application Type: General Proposal	Abutting Road Width: -
Nature of Development: New	Revenue Survey No/Survey No: -
Location: Old Area	Tram No: -
Sub Location: NA	Hoisting No: -
Proposed Name: -	Area No: -
Street No: -	North: -
Road/Street: -	South: -
East: -	West: -

TABLE DETAILS	
AREA OF PLOT (Minimum)	(A)
Net Plot Area (Gross Plot Area - Deduction for Gross Plot Area)	(A) Deductions
Deductions for Balance Plot Area (from Gross Plot Area)	
G.P. Area	30.35
Net Plot Area (Net Plot Area - Room/Area/Verandah/Space)	(A) Deductions
Net Area for Coverage (Net Plot Area)	(A) Deductions
Net Area for Plinth (Net Plot Area - Road/Driveway Area)	(A) Deductions

COLOR INDEX	
PLANT BOUNDARY	Green
EXISTING ROAD	Red
PROPOSED WORK COVERAGE AREA	Blue
EXISTING (To be retained)	Yellow
EXISTING (To be demolished)	Orange

PARKING CALCULATION		
Parking Type	Prop. No.	Prop. Area
Other Parking	1	36.37
Total Area	1	36.37

MARGIN DETAIL					
Building / Wing	Road Name	Front Margin	Rear Margin	Side Margin	Setback Margin
A (BUILDING)	4.87M WIDE ROAD	4.54	3.07	5.94	0.91

FAR & Tenement Details (Table 40-1)						
Building	No. of Store	Total Built Up Area (Sq.Mt)	Deductions (Area in Sq.Mt)	Proposed FAR Area (Sq.Mt)	Total FAR Area (Sq.Mt)	Tenement No.
A (BUILDING)	1	663.21	5.10	66.91	667.20	01
Grand Total	1	663.21	5.10	66.91	667.20	01

### BRIEF SPECIFICATION

FOUNDATION..... CEMENT CONCRETE (1:1.5:3)  
 BRICK WORK IN FOUNDATION & SUPERSTRUCTURE  
 FIRST CLASS BRICK WORK IN CEMENT MORTAR (1:6)  
 D.P.C.....25 D.P.C. IN CEMENT CONCRETE (1:2:4)  
 FLOOR.....25 I.P.S. OVER 75 P.C.C.  
 ROOF.....100 THK. R.C.C. ROOF (1:1.5:3)  
 LINTEL.....150 THK. R.C.C. LINTEL (1:1.5:3)  
 STAIRS.....RISE- 150, TREAD- 250

### DETAILS OF AREA

TOTAL AREA (AS PER DEED) ..... 394.65 SQM.  
 TOTAL AREA (AS PER SITE) ..... 368.78 SQM.  
 GROUND FLOOR AREA..... 221.07 SQM.  
 FIRST FLOOR AREA..... 221.07 SQM.  
 SECOND FLOOR AREA..... 221.07 SQM.  
 TOTAL COVERED AREA..... 663.21 SQM.  
 % PLINTH AREA..... 59.94 %  
 FAR ..... 1.80

### SCHEDULE

D = 1.500X2.100      W = 1.800X1.200  
 D1 = 1.050X2.100      V = 0.600X0.600  
 D2 = 0.800X2.100

### TITLE OF DRAWING

PLAN OF PROPOSED RESIDENTIAL BUILDING OF (1) IBRAR AHMAD S/O NEYAZ AHMAD (2) MINOR ADIL AHMAD S/O IBRAR AHMAD Residence BHULI ROAD NAYA BAZAR, Dist Dharwad. Mouza. PANDARPALA ND. 04 Old Khata No 71, New Khata No 379. New Plot No 3292 Old Plot No 2132, 2141, 2142 Area 5.90 - Kathas DIST. OF DHANBAD (JHARKHAND).

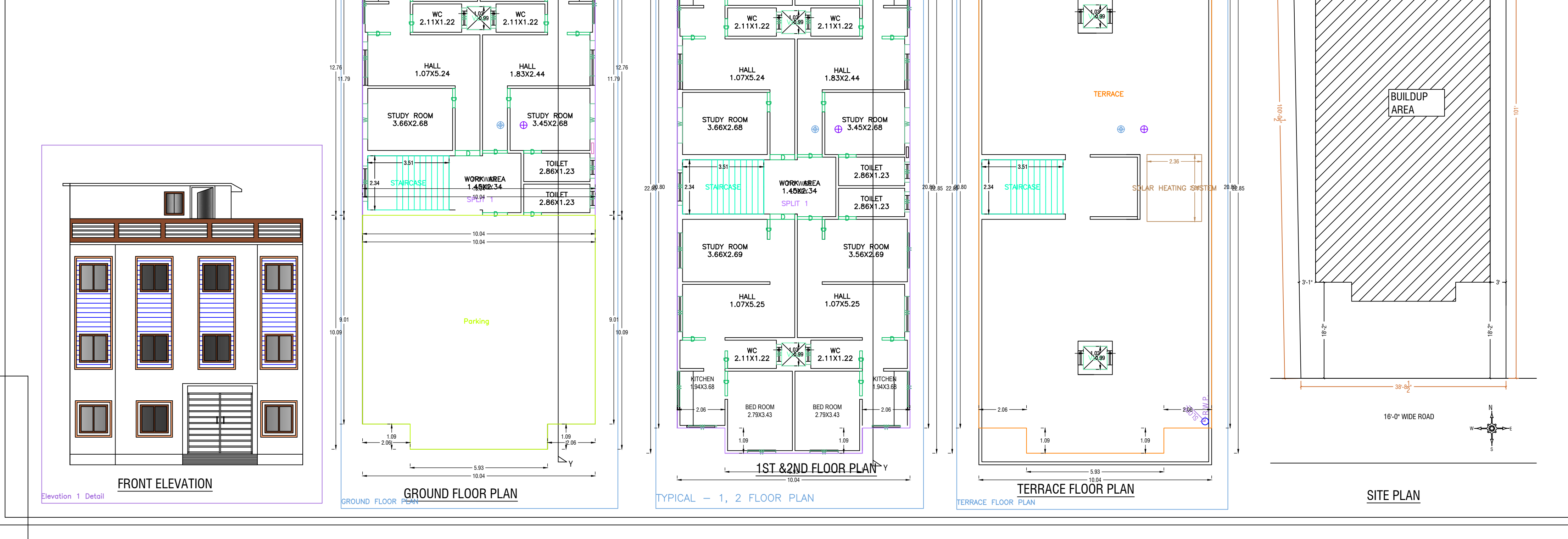
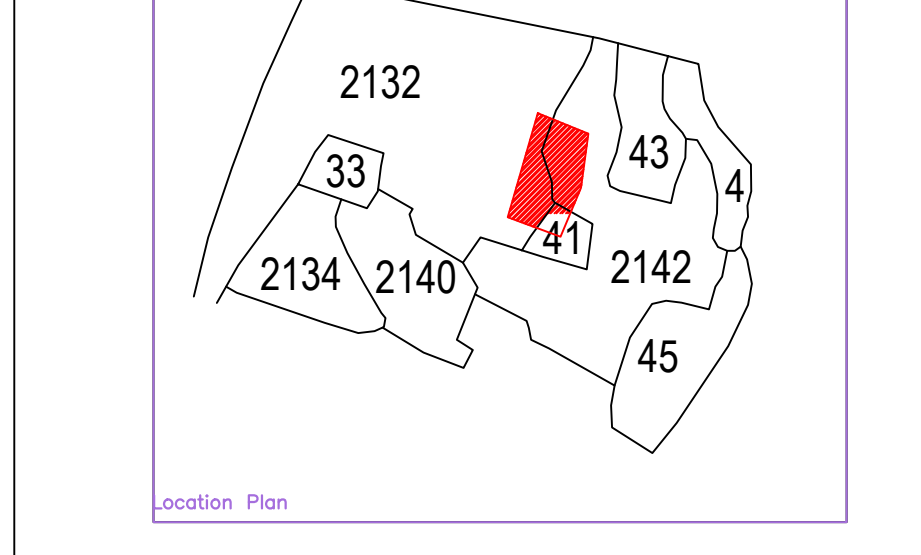
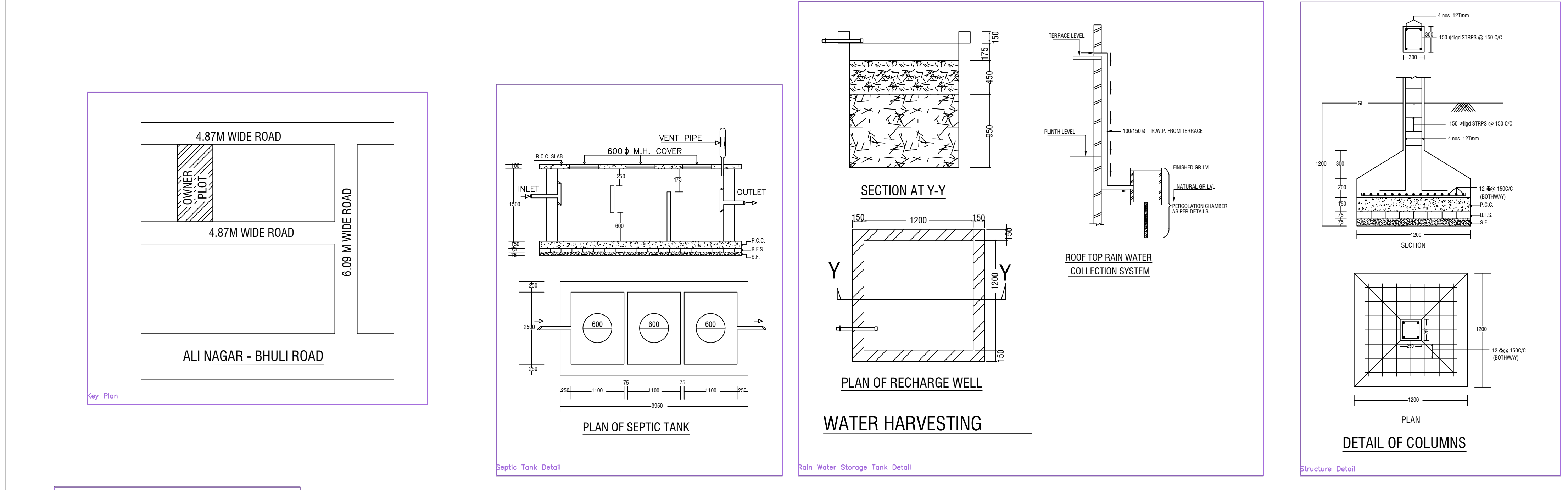
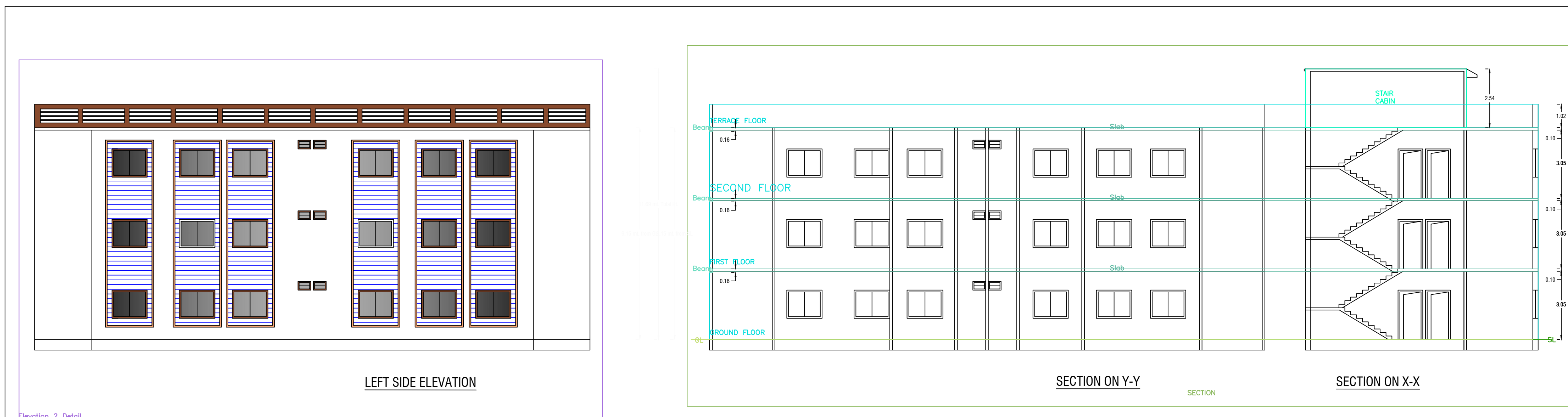

Building A (BUILDING)					
Floor Name	Total Built Up Area (Sq.Mt)	Deductions (Area in Sq.Mt)	Proposed FAR Area (Sq.Mt)	Total FAR Area (Sq.Mt)	Tenement No.
Ground Floor	221.07	5.10	66.91	123.14	01
First Floor	221.07	0.00	219.03	219.03	00
Second Floor	221.07	0.00	219.03	219.03	00
Terrace Floor	0.00	0.00	0.00	0.00	00
Total	663.21	5.10	66.91	667.20	01
Total Number of Store Buildings	1				
Total	663.21	5.10	66.91	667.20	01

SCHEDULE OF JOINERY:				
BUILDING NAME	NAME	LENGTH	HEIGHT	NO. OF
A (BUILDING)	C	0.76	2.10	03
A (BUILDING)	C	0.84	2.10	06
A (BUILDING)	C	0.88	2.10	04
A (BUILDING)	C	0.88	2.10	04
A (BUILDING)	D	1.07	2.10	21
Total				37

SCHEDULE OF JOINERY:				
BUILDING NAME	NAME	LENGTH	HEIGHT	NO. OF
A (BUILDING)	W	0.87	1.20	10
A (BUILDING)	W	1.27	1.20	20
A (BUILDING)	W	1.32	1.20	33
Total				63

UphBUA Table for Building A (BUILDING)						
FLOOR	Name	UphBUA Type	UphBUA Area	Capal Area	No. of Rooms	No. of Tenement
GROUND FLOOR	SPLIT 1	FLAT	342.18	342.09	13	1
Total			342.18	342.09	13	1

