

SITE PLAN
SCALE - 1:100

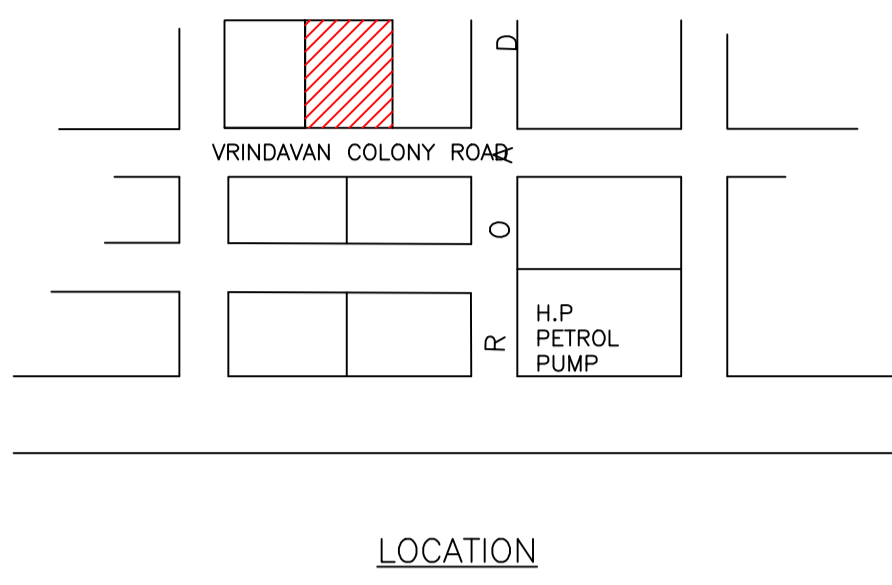

LOCATION

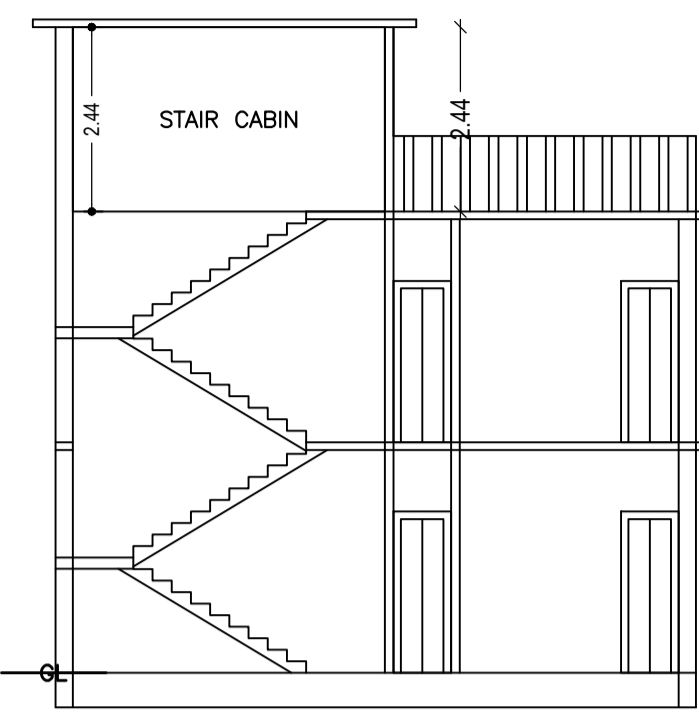

SECTION ON: 'A-A'
SCALE - 1:100

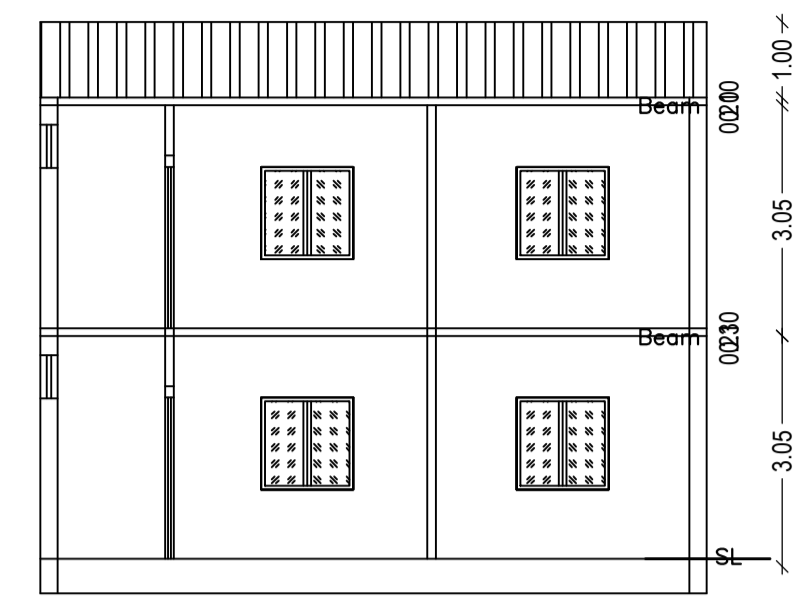

SECTION ON: 'B-B'
SCALE - 1:100

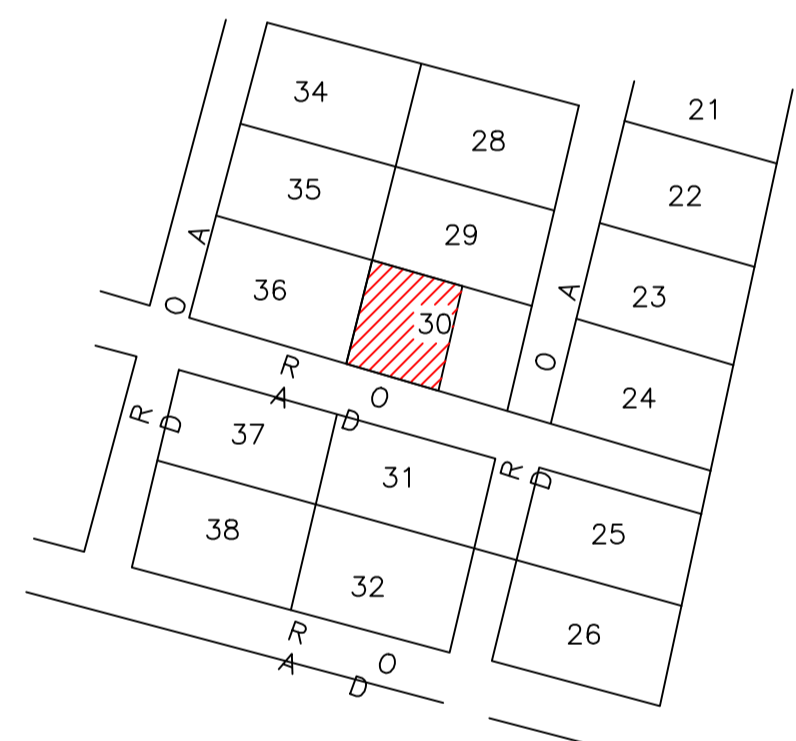

KEY PLAN
SCALE - NTS

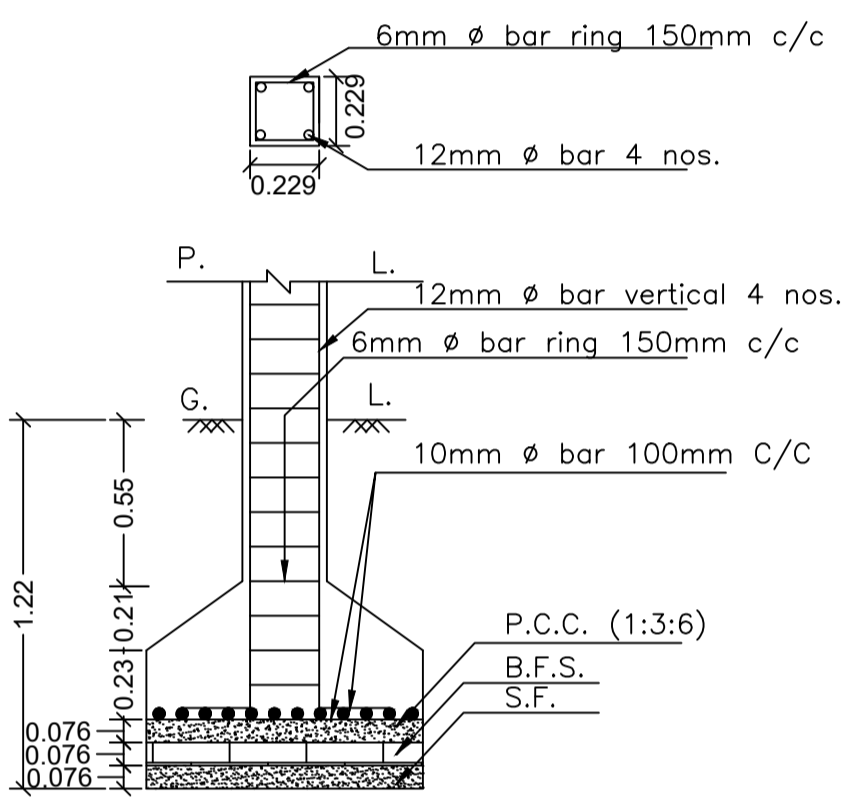

SECTION ON- ZZ
SCALE - 1:25

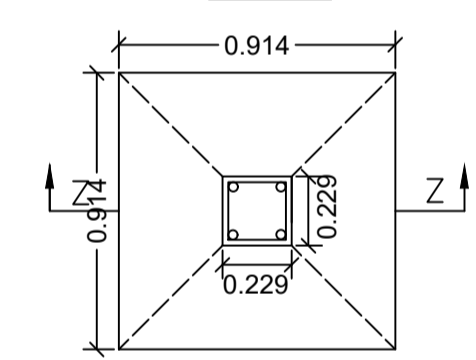

PLAN
DETAILS OF COLUMN FOOTING
SCALE - 1:25

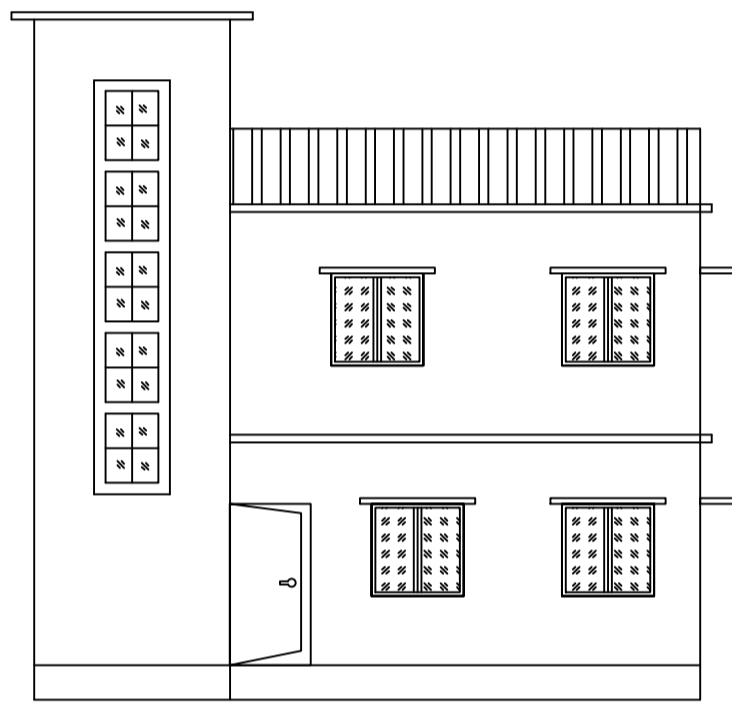

FRONT ELEVATION
SCALE - 1:100

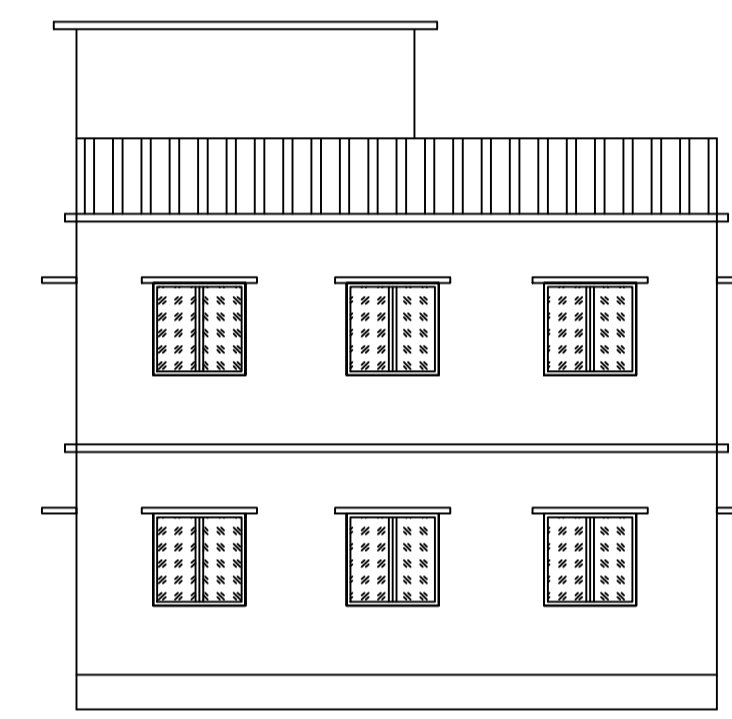

RIGHT SIDE ELEVATION
SCALE - 1:100

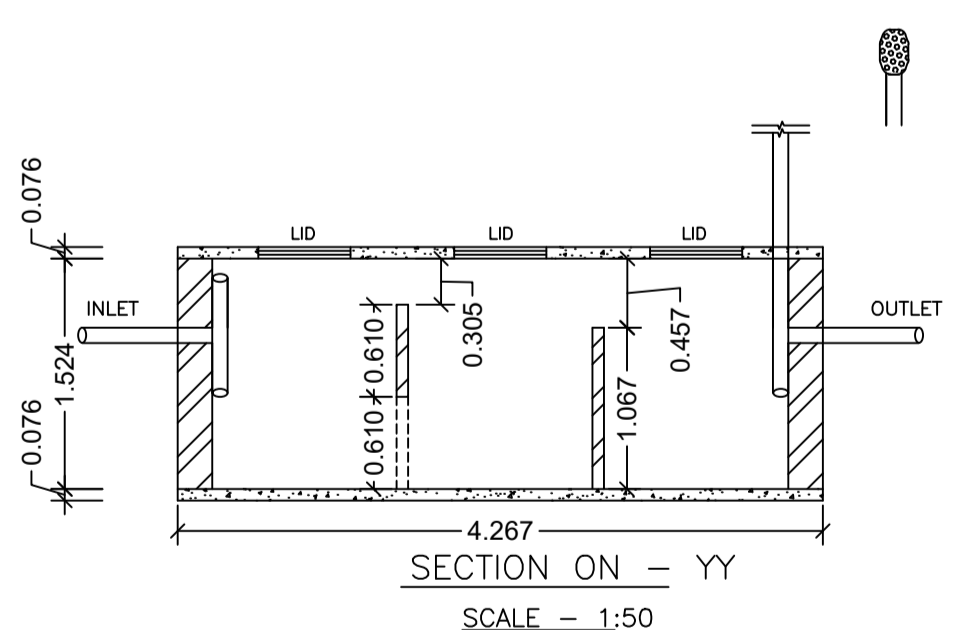

SECTION ON - YY
SCALE - 1:50

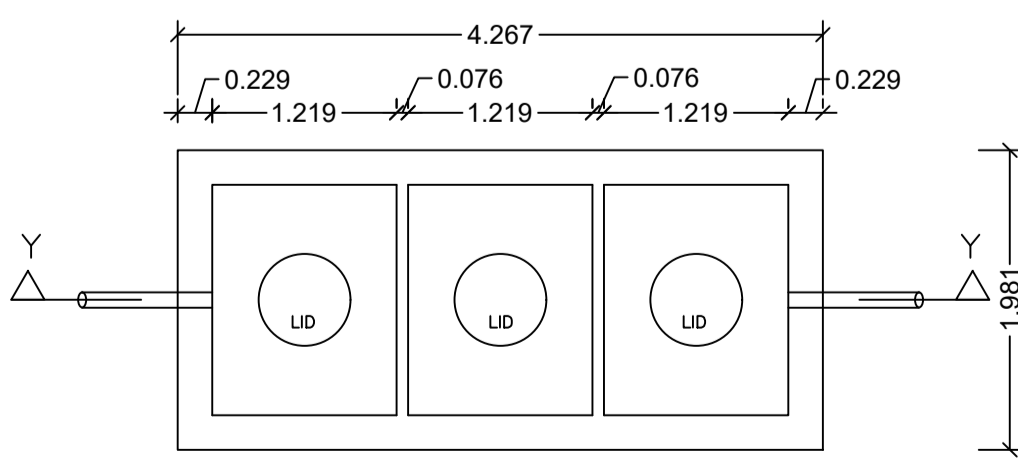

DETAILS OF SEPTIC TANK
SCALE - 1:50

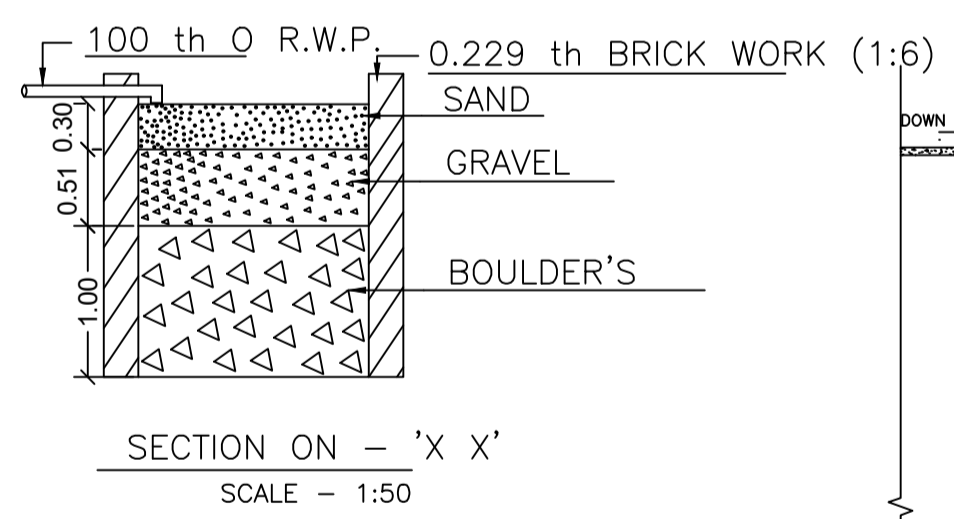

SECTION ON - 'X X'
SCALE - 1:50

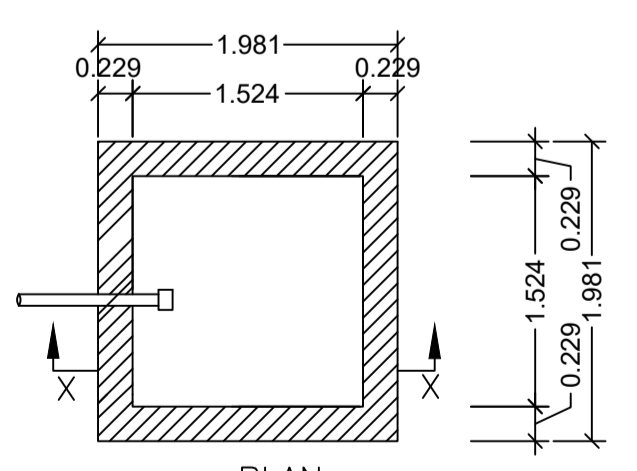

PLAN
DETAILS OF WATER HARVESTING
SCALE - 1:50

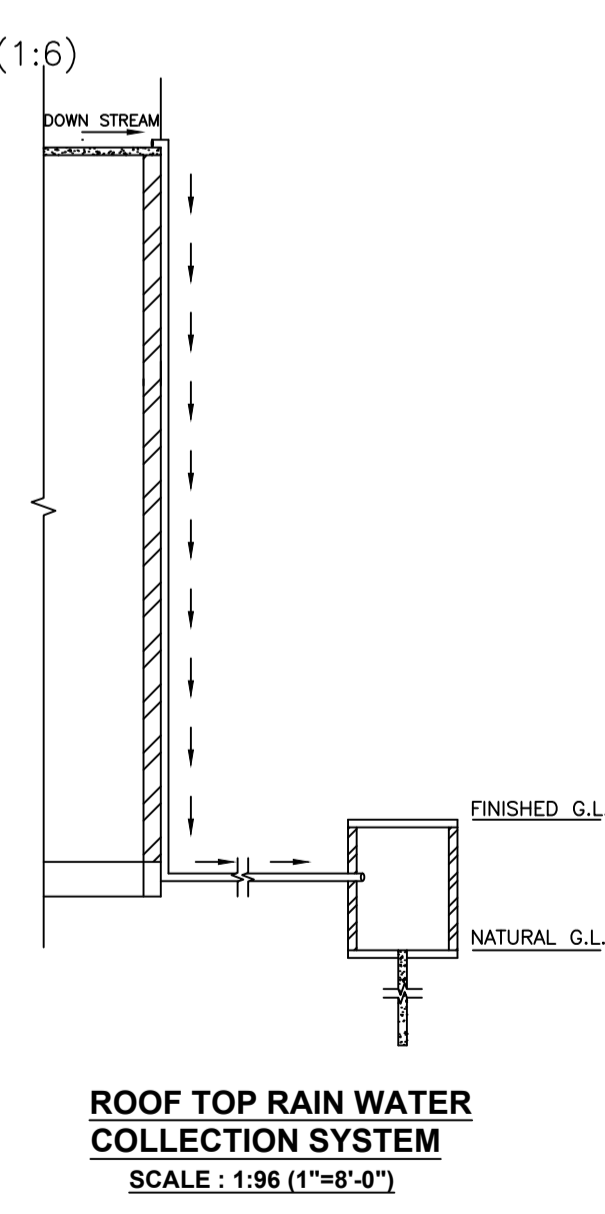

ROOF TOP RAIN WATER COLLECTION SYSTEM
SCALE : 1:96 (1"=8'-0")

Building :A (A)

Floor Name	Total Built Up Area (Sq.mt.)	Proposed FAR Area (Sq.mt.) Resi.	Total FAR Area (Sq.mt.)	Total Consumed Additional FAR Area (Sq.mt.)	Tnmt (No.)
Ground Floor	74.65	74.65	74.65	74.65	01
First Floor	74.65	74.65	74.65	74.65	00
Terrace Floor	0.00	0.00	0.00	0.00	00
Total:	149.30	149.30	149.30	149.30	01
Total Number of Same Buildings :	1				
Total :	149.30	149.30	149.30	149.30	01

FAR & Tenement Details (Table 4c-1)

Building	No. of Same Bldg	Total Built Up Area (Sq.mt.)	Proposed FAR Area (Sq.mt.) Resi.	Total FAR Area (Sq.mt.)	Total Consumed Additional FAR Area (Sq.mt.)	Tnmt (No.)
A (A)	1	149.30	149.30	149.30	149.30	01
Grand Total :	1	149.30	149.30	149.30	149.30	01

UnitBUA Table for Building :A (A)

FLOOR	Name	UnitBUA Type	UnitBUA Area	Carpel Area	No. of Rooms	No. of Tenement
GROUND FLOOR PLAN	SPLIT A	FLAT	149.31	149.24	7	1
FIRST FLOOR PLAN	SPLIT A	FLAT	0.00	0.00	7	0
Total:	-	-	149.31	149.24	14	1

Proposal Basic Information

Proposal File No.	DMC/BP/0259/W23/2022
Owner Name	MADHU RANI
Khata No	OLD-45, NEW-71
Plot No	OLD-678 (CO-OP, PLOT NO-30 B PART) NEW-877
Village Name	Sabalpur
Use	Residential
SubUse	Bungalow/ Dwelling / Non Apartment

AREA STATEMENT

AREA OF PLOT (Minimum)	(A)	SQ.MT.
NET AREA OF PLOT(Gross Plot Area - Deduction from Gross Plot area)	(A-Deductions)	133.15
Deduction for Balance Plot Area(from Gross Plot Area)		
Common Plot		12.66
BALANCE AREA OF PLOT(Net Plot Area - Recreational/Amenity space)	(A-Deductions)	120.49
PLOT AREA FOR COVERAGE(Net Plot Area)	(A-Deductions)	133.15
Plot Area for FAR (Net Plot Area + RoadWidening Area)	(A-Deductions)	133.15
COVERAGE CHECK		
Permissible Coverage area (70.00 %)		93.20
Proposed Coverage Area (56.07 %)		74.65
Total Prop. Coverage Area (56.07 %)		74.65
Balance coverage area (13.93 %)		18.55
FAR CHECK		
Perm. FAR Area (2.50)		332.88
Total Perm. FAR area		332.88
Residential FAR		149.31
Proposed FAR Area		149.31
Total Proposed FAR Area		149.31
Consumed FAR (Factor)		1.12
Balance FAR Area		183.57
BUILT UP AREA CHECK		
Total Proposed BuiltUp Area		149.30
ARCHITECT (Regd)	SANJEEV KUMAR RAY	
ENGINEER (Regd)		
SUPERVISOR (Regd)		
OWNER (Regd)	MADHU RANI	
DEVELOPMENT AUTHORITY LOCAL BODY		

COLOR INDEX

PLOT BOUNDARY	Black
ABUTTING ROAD	Green
PROPOSED CONSTRUCTION	Red
COMMON PLOT	Yellow
ROAD WIDENING AREA	Orange
EXISTING (To be retained)	Blue
EXISTING (To be demolished)	Light Blue

Buildingwise Floor FAR Details

Floor Name	Building Name A (A)		Total	
	Proposed Built Up Area (Sq.mt.)	Proposed FAR Area (Sq.mt.)	Total Proposed Built Up Area (Sq.mt.)	Total FAR Area (Sq.mt.)
Ground Floor	74.65	74.65	74.65	74.65
First Floor	74.65	74.65	74.65	74.65
Terrace Floor	0.00	0.00	0.00	0.00
Total :	149.30	149.30	149.30	149.30

Building USE/SUBUSE Details

Building Name	Building Use	Building SubUse	Building Structure
A (A)	Residential	Bungalow/ Dwelling / Non Apartment	Non-Highrise

SCHEDULE OF DOOR:

BUILDING NAME	NAME	LENGTH	HEIGHT	NOS
A (A)	D	0.76	2.10	04
A (A)	D	0.91	2.10	02
A (A)	D	1.04	2.10	02
A (A)	D	1.07	2.10	07

SCHEDULE OF WINDOW/VENTILATION:

BUILDING NAME	NAME	LENGTH	HEIGHT	NOS
A (A)	V	0.61	1.20	04
A (A)	W	1.22	1.20	12
A (A)	W	1.82	1.20	02

LTP NAME AND SIGNATURE SANJEEV KUMAR RAY DMC/ENG/0001/2019	STRUCTURAL ENG'S NAME AND SIGNATURE	BUILDER NAME AND SIGNATURE	DIGITAL SIGNATURE
--	-------------------------------------	----------------------------	-------------------

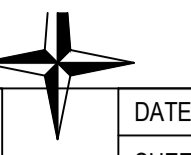

Proposal Basic Information	
Proposal File No.	DMC/BP/0259/W23/2022
Owner Name	MADHU RANI
Khata No	OLD-45, NEW-71
Plot No	OLD-678 (CO-OP, PLOT NO-30 B PART) NEW-877
Village Name	Sabalpur
Use	Residential
SubUse	Bungalow/ Dwelling / Non Apartment

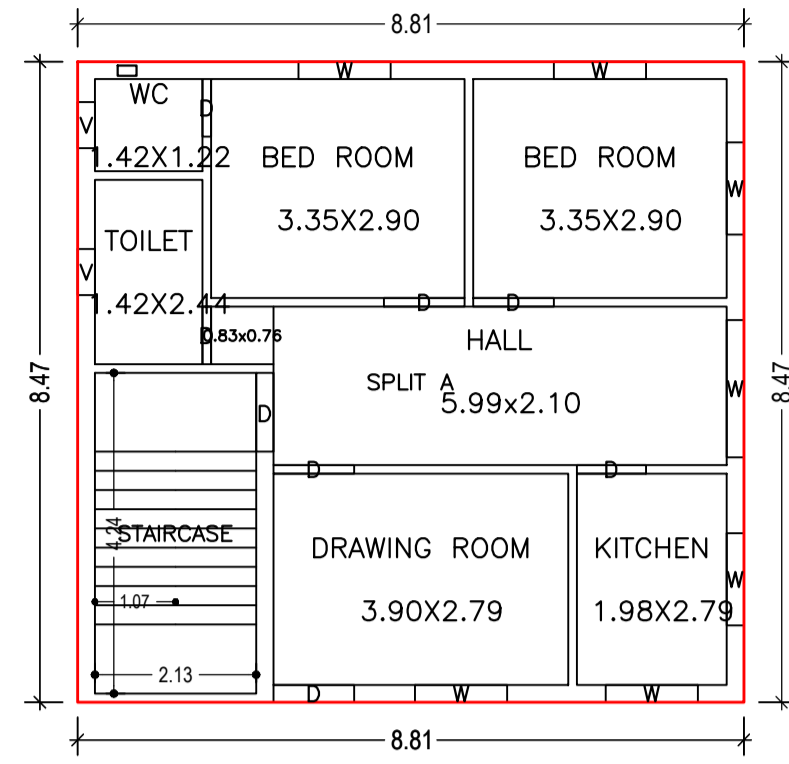

GROUND FLOOR PLAN
(Proposed)
(SCALE 1:100)

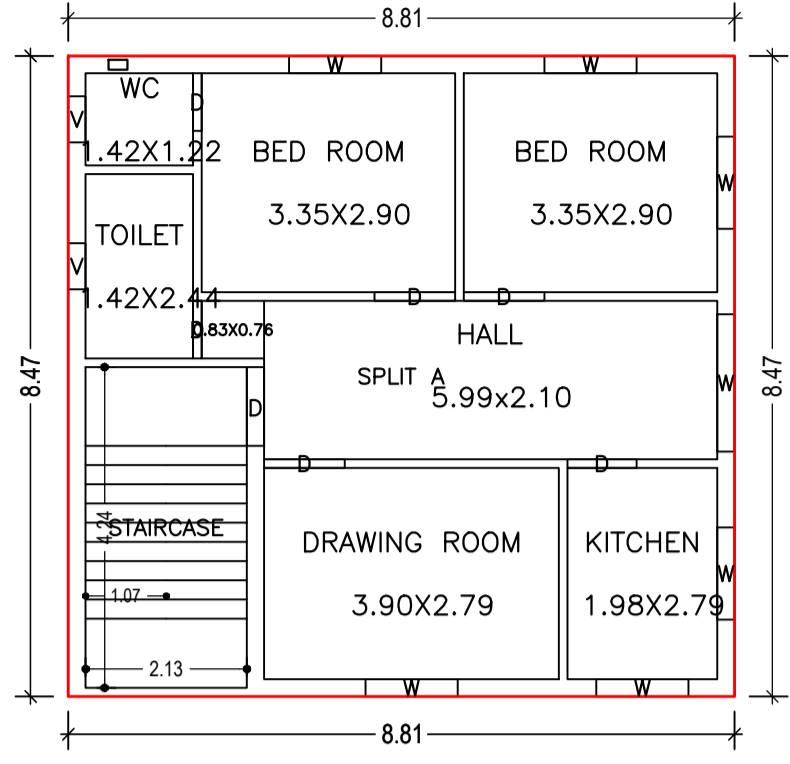

FIRST FLOOR PLAN
(Proposed)
(SCALE 1:100)

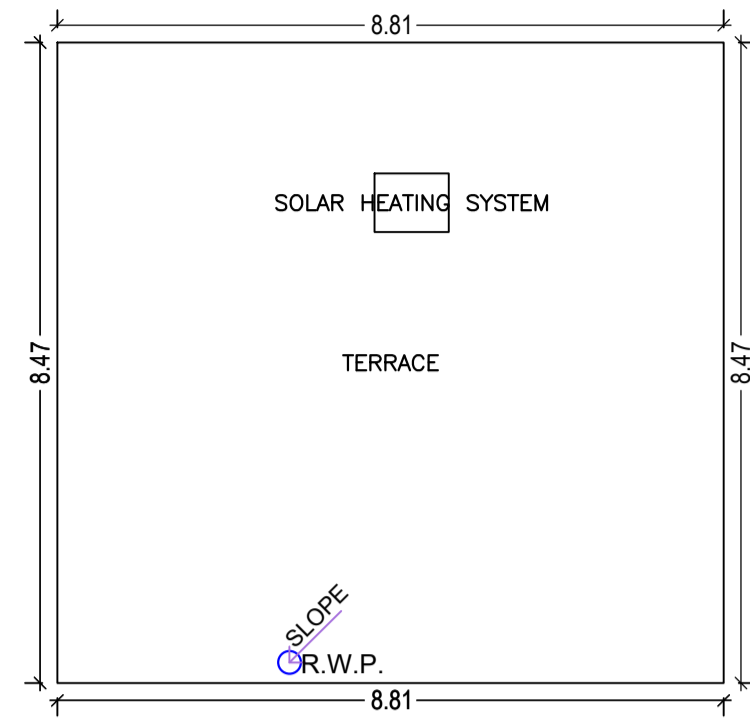

TERRACE FLOOR PLAN
(SCALE 1:100)

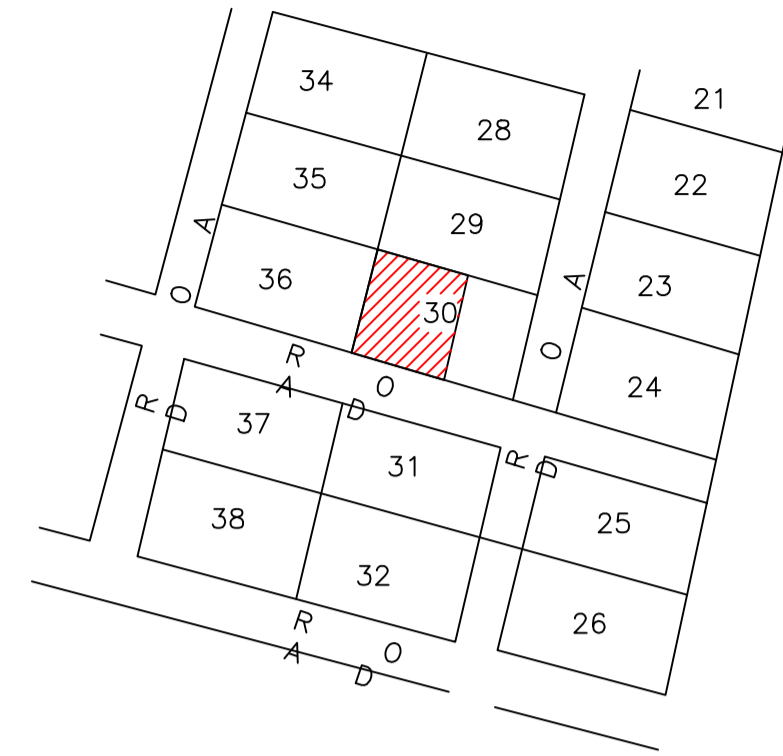

KEY PLAN
SCALE - NTS

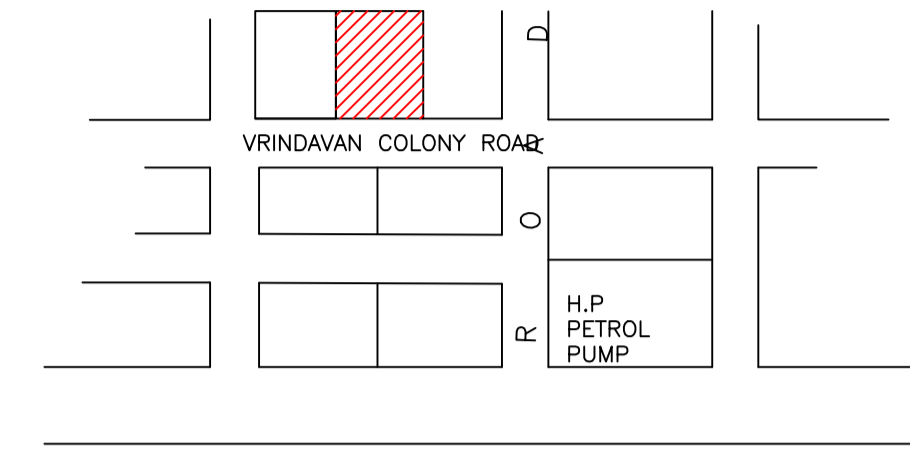

LOCATION

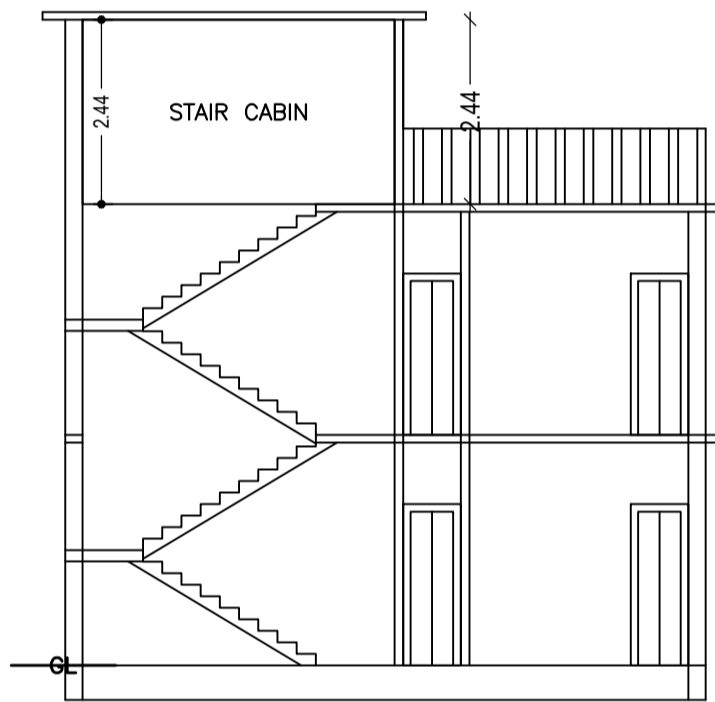

SECTION ON: 'A-A'
SCALE - 1:100

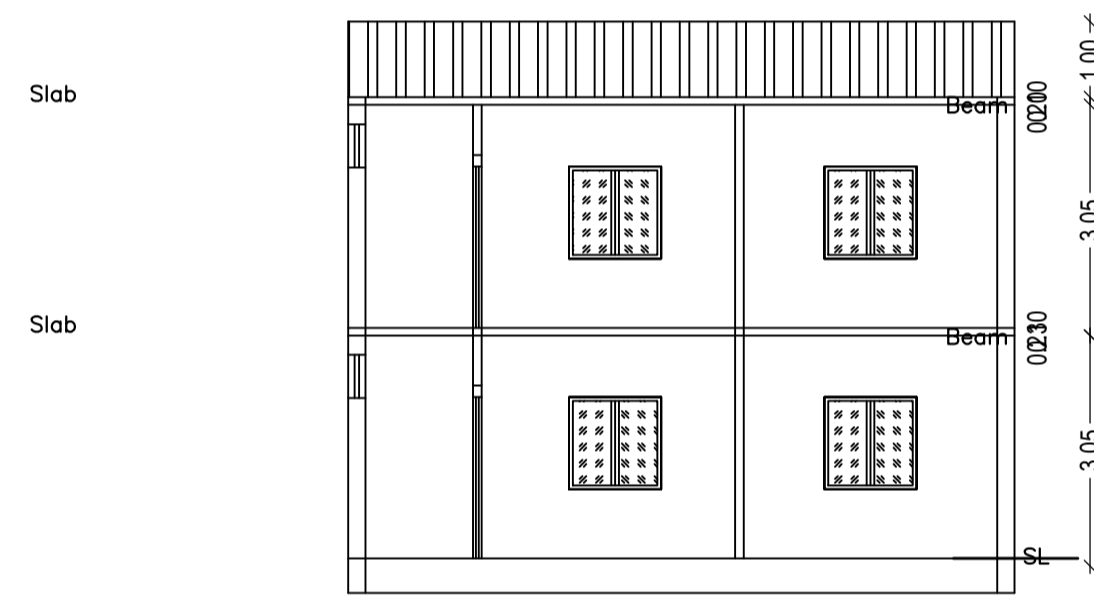

SECTION ON: 'B-B'
SCALE - 1:100

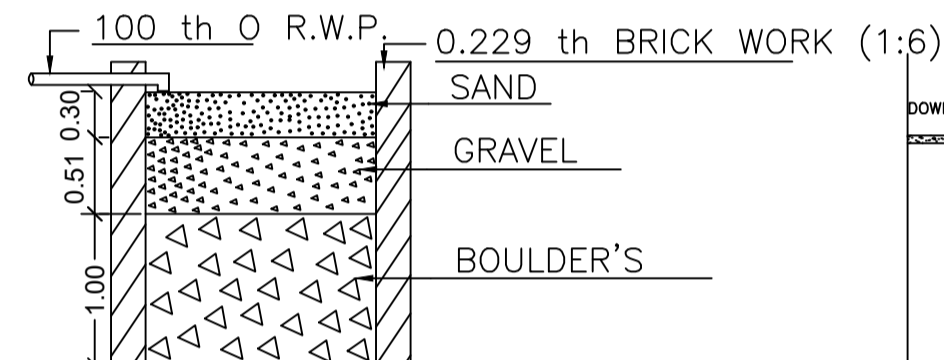

SECTION ON - 'X X'
SCALE - 1:50

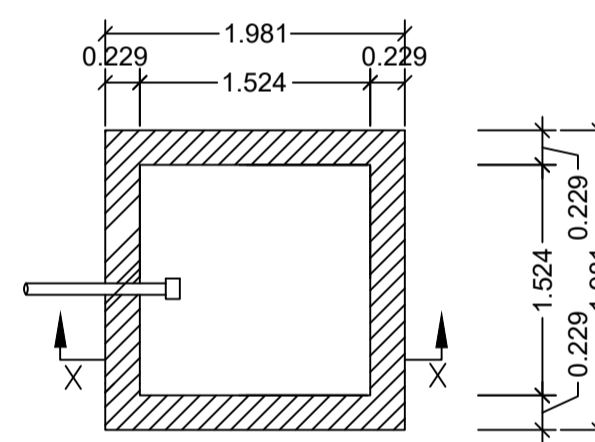

PLAN
DETAILS OF WATER HARVESTING
SCALE - 1:50

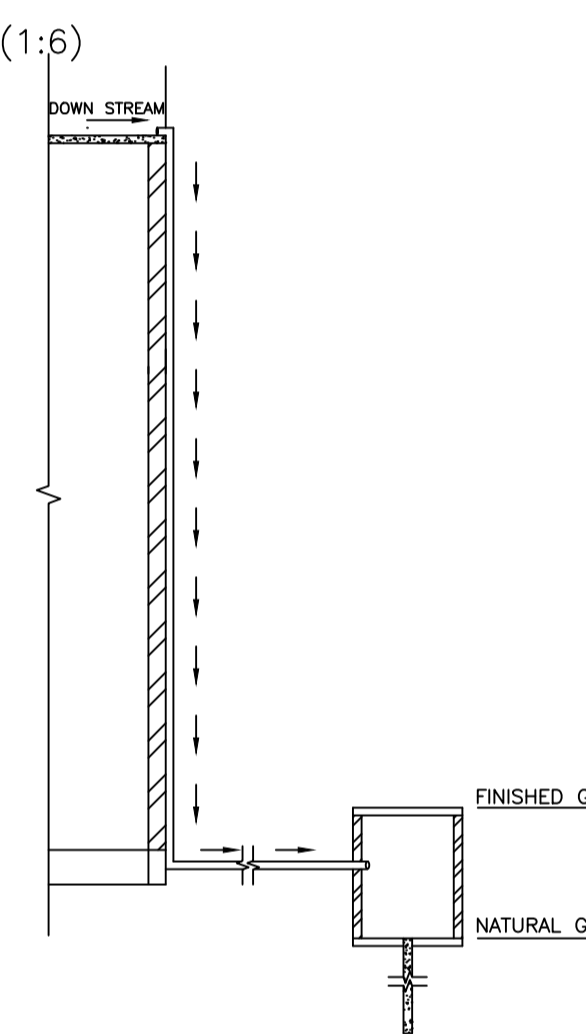

ROOF TOP RAIN WATER
COLLECTION SYSTEM
SCALE : 1:96 (1"=8'-0")

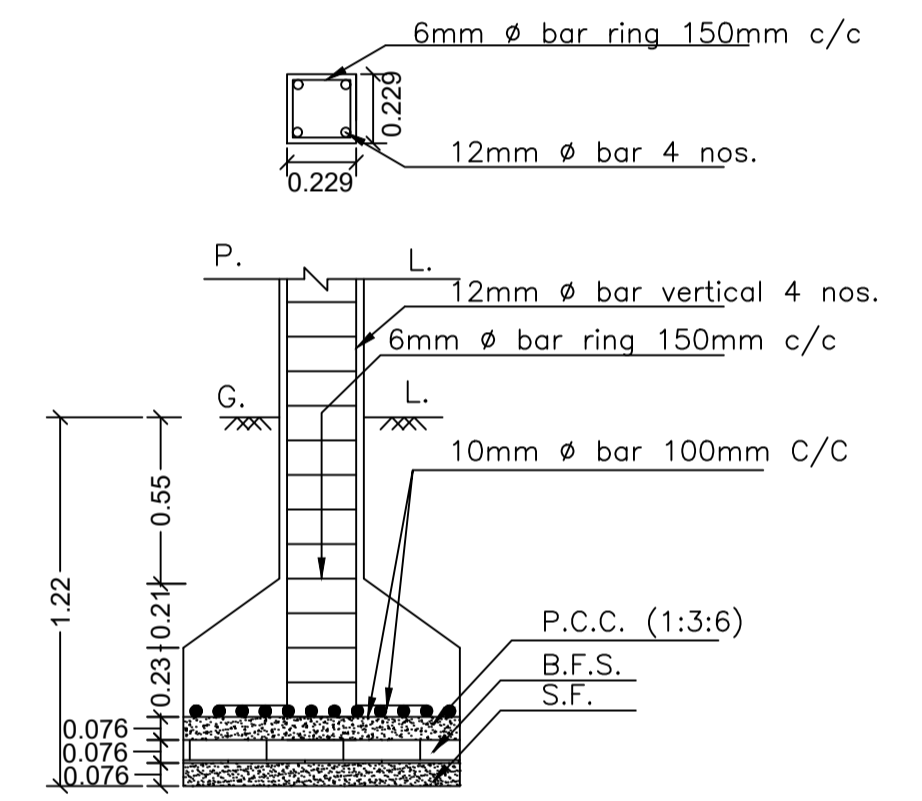

SECTION ON- ZZ
SCALE - 1:25

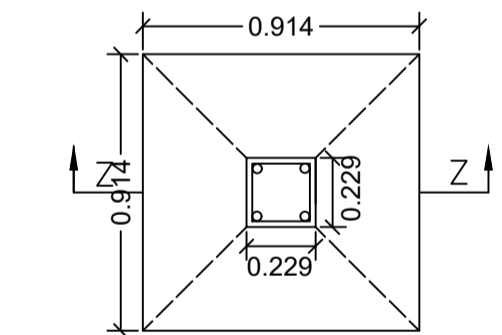

PLAN
DETAILS OF COLUMN FOOTING
SCALE - 1:25

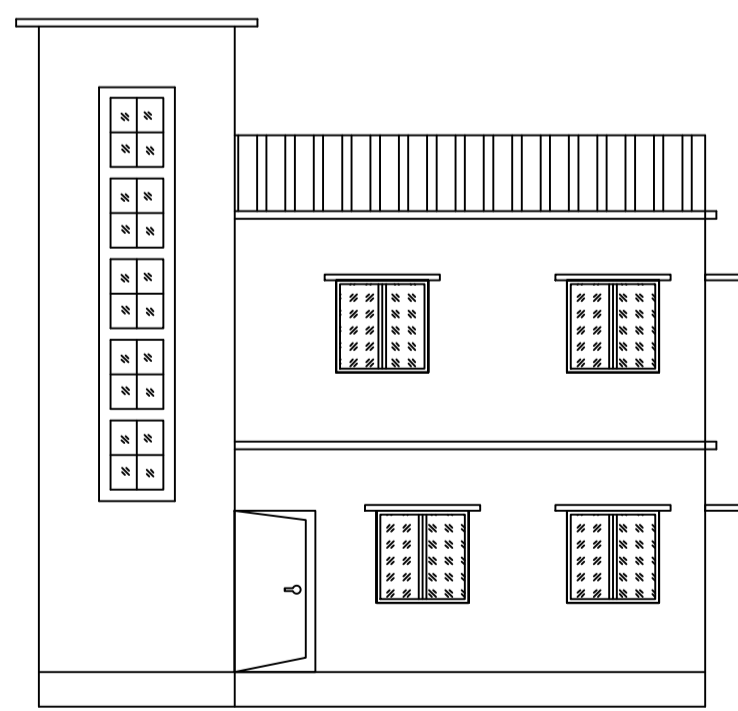

FRONT ELEVATION
SCALE - 1:100

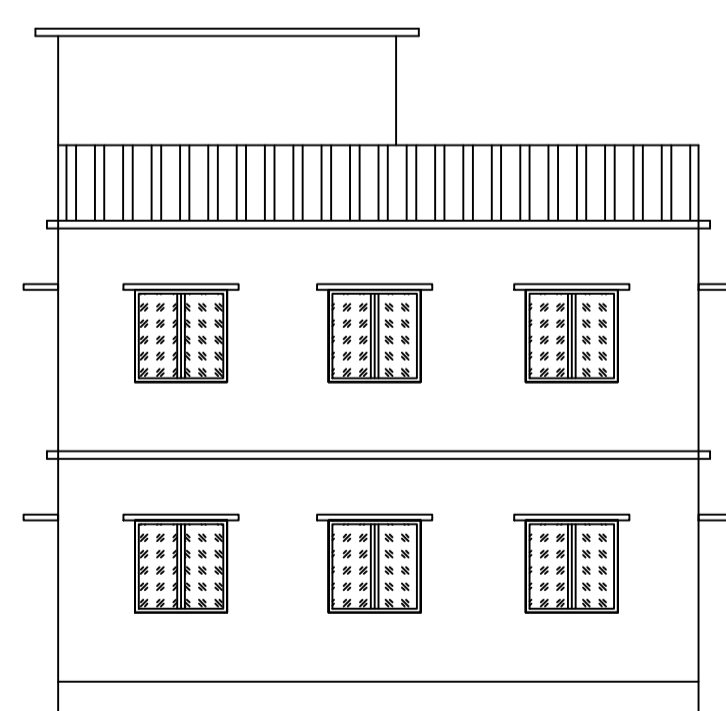

RIGHT SIDE ELEVATION
SCALE - 1:100

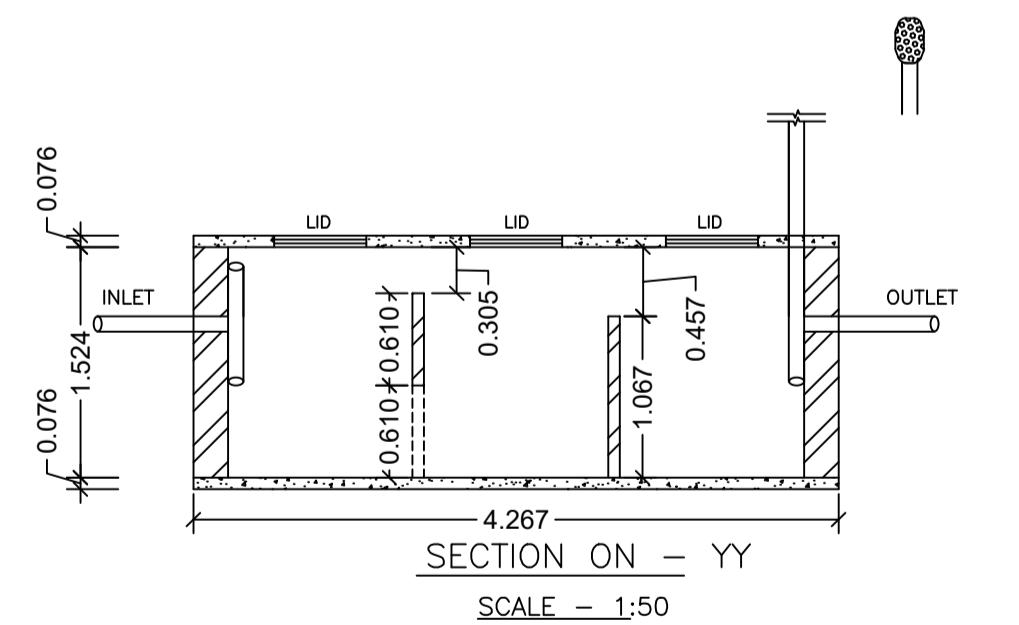

SECTION ON - YY
SCALE - 1:50

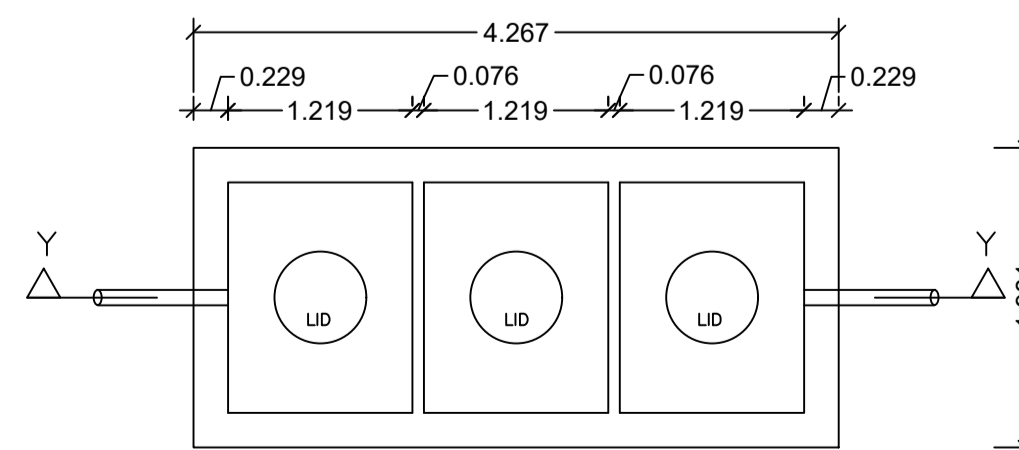

DETAILS OF SEPTIC TANK
SCALE - 1:50

LTP NAME AND SIGNATURE	STRUCTURAL ENG'S NAME AND SIGNATURE	BUILDER NAME AND SIGNATURE	DIGITAL SIGNATURE
SANJEEV KUMAR RAY DMC/ENG/0001/2019			