

Proposal Basic Information

Proposal File No.	DMC/BP/0214/W17/2022
Owner Name	SRI GIRISH SINGH
Khata No	OLD-48 NEW-601
Plot No	OLD-208,212 NEW-91,94
Village Name	Panarpala
Use	Residential
SubUse	Bungalow/ Dwelling / Non Apartment

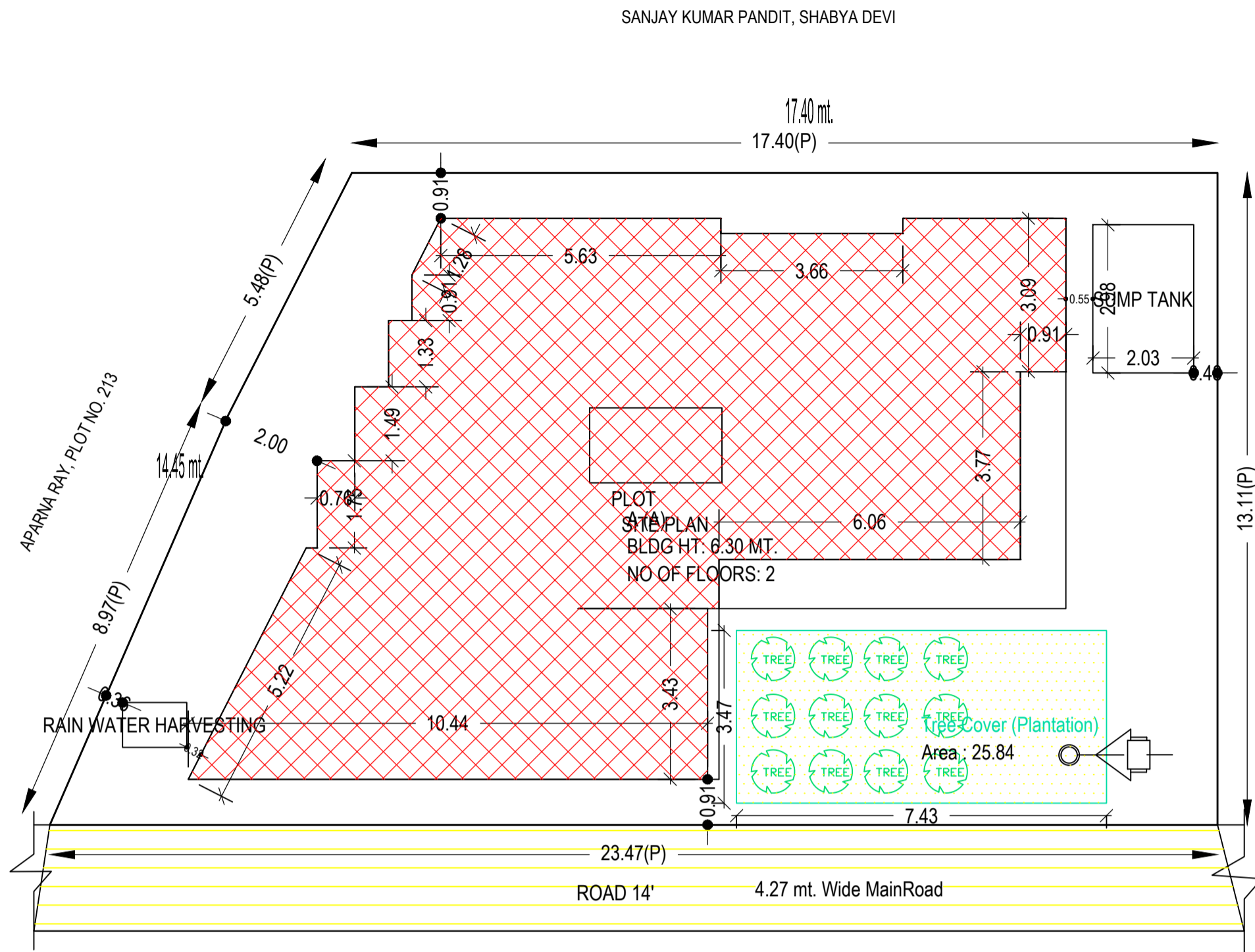

**SITE PLAN**  
1"=8'

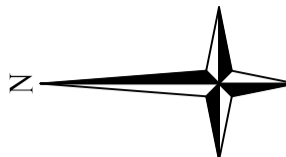
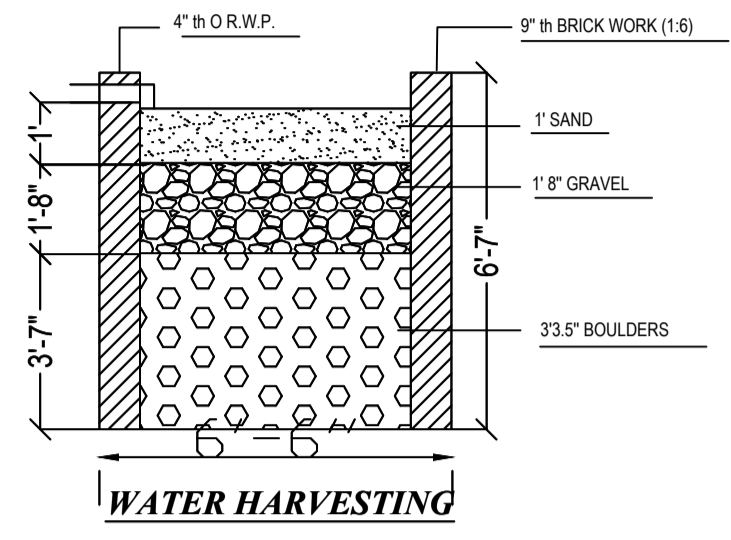

**WATER HARVESTING**

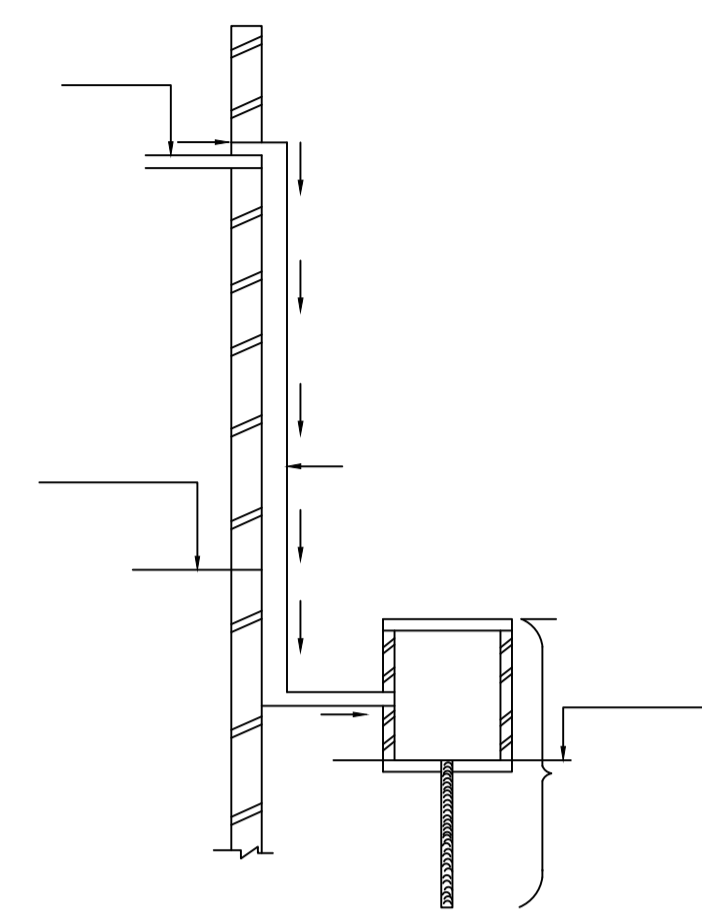

**ROOF TOP RAIN WATER COLLECTION SYSTEM**

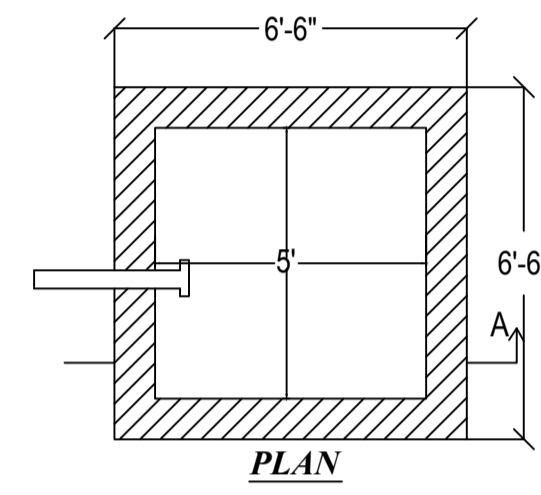

**PLAN**

AREA STATEMENT DHANBAD MUNICIPAL CORPORATION	VERSION NO.: 1.0.66 VERSION DATE: 16/10/2020	SQ.MT.
<b>PROJECT DETAIL:</b>		
Region: JHARKHAND URBAN LOCAL BODIES	Plot Use: Residential	
District: DHANBAD	Plot SubUse: Bungalow/ Dwelling / Non Apartment	
Authority: DHANBAD MUNICIPAL CORPORATION	PlotNearbyReligiousStructure: NA	
Inward_No: DMC/BP/0214/W17/2022	Plot/SubPlot No: OLD-208,212 NEW-91,94	
Application Type: General Proposal	North: Plot No. - APARNA RAY, PLOT NO.213	
Project Type: Building Permission	South: Plot No. - PLOT NO. 08	
Nature of Development: New	East: Plot No. - SANJAY KUMAR PANDIT AND SHABYA DEVI	
Location of Development Area: Old Area	West: Road Width - 4.26	
<b>AREA DETAILS:</b>		
AREA OF PLOT (Minimum)	(A)	269.30
NET AREA OF PLOT(Gross Plot Area - Deduction from Gross Plot area)	(A-Deductions)	269.30
Deduction for Balance Plot Area(from Gross Plot Area)		
Common Plot Total		25.84
BALANCE AREA OF PLOT(Net Plot Area - Recreational/Amenity space)	(A-Deductions)	243.46
PLOT AREA FOR COVERAGE(Net Plot Area)	(A-Deductions)	269.30
Plot Area for FAR (Net Plot Area + RoadWidening Area)	(A-Deductions)	269.30
<b>COVERAGE CHECK</b>		
Permissible Coverage area ( 60.00 % )		161.58
Proposed Coverage Area ( 49.31 % )		132.80
Total Prop. Coverage Area ( 49.31 % )		132.80
Balance coverage area ( 10.69 % )		28.78
<b>FAR CHECK</b>		
Perm. FAR Area ( 1.500 )		403.95
Total Perm. FAR area		403.95
Residential FAR		214.12
Proposed FAR Area		214.12
Total Proposed FAR Area		214.12
Consumed FAR (Factor)		0.80
Balance FAR Area		189.83
<b>BUILT UP AREA CHECK</b>		
Total Proposed BuiltUp Area		237.31
ARCHITECT (Regd)	Santosh	
ENGINEER (Regd)		
SUPERVISOR (Regd)		
OWNER (Regd)	SRI GIRISH SINGH	
DEVELOPMENT AUTHORITY		LOCAL BODY

Building :A (A)

Floor Name	Total Built Up Area (Sq.mt.)	Deductions (Area in Sq.mt.)	Proposed FAR Area (Sq.mt.)		Total Consumed Additional FAR Area (Sq.mt.)	Trmt (No.)
			Parking	Resi.		
Ground Floor	132.80	23.19	109.61	109.61	109.61	01
First Floor	104.51	0.00	104.51	104.51	104.51	00
Terrace Floor	0.00	0.00	0.00	0.00	0.00	00
<b>Total :</b>	<b>237.31</b>	<b>23.19</b>	<b>214.12</b>	<b>214.12</b>	<b>214.12</b>	<b>01</b>
Total Number of Same Buildings :	1					
<b>Total :</b>	<b>237.31</b>	<b>23.19</b>	<b>214.12</b>	<b>214.12</b>	<b>214.12</b>	<b>01</b>

SCHEDULE OF DOOR:

BUILDING NAME	NAME	LENGTH	HEIGHT	NOS
A (A)	D	0.65	2.10	01
A (A)	D	0.76	2.10	03
A (A)	D	0.91	2.10	03
A (A)	D	1.07	2.10	01
A (A)	D	1.13	2.10	03
A (A)	D	1.22	2.10	02
A (A)	ARCH	3.66	2.10	01

SCHEDULE OF WINDOW/VENTILATION:

BUILDING NAME	NAME	LENGTH	HEIGHT	NOS
A (A)	V	0.61	1.20	06
A (A)	W	0.94	1.20	02
A (A)	W	1.26	1.20	02
A (A)	W	1.52	1.20	08
A (A)	W	1.83	1.20	01
A (A)	W	2.06	1.20	01
A (A)	W	3.05	1.20	02

UnitBUA Table for Building :A (A)

FLOOR	Name	UnitBUA Type	UnitBUA Area	Carpet Area	No. of Rooms	No. of Tenement
GROUND FLOOR PLAN	SPLIT A	FLAT	214.12	214.06	8	1
FIRST FLOOR PLAN	SPLIT A	FLAT	0.00	0.00	8	0
<b>Total:</b>	-	-	<b>214.12</b>	<b>214.06</b>	<b>16</b>	<b>1</b>

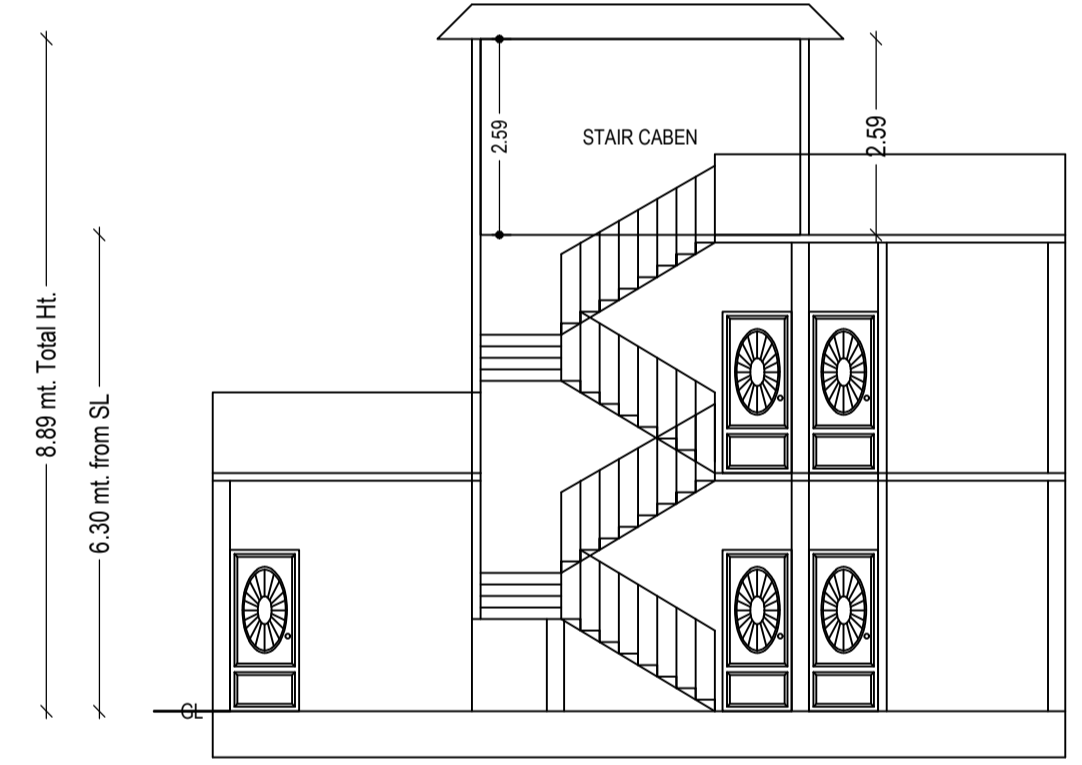

**SECTION ON XX**

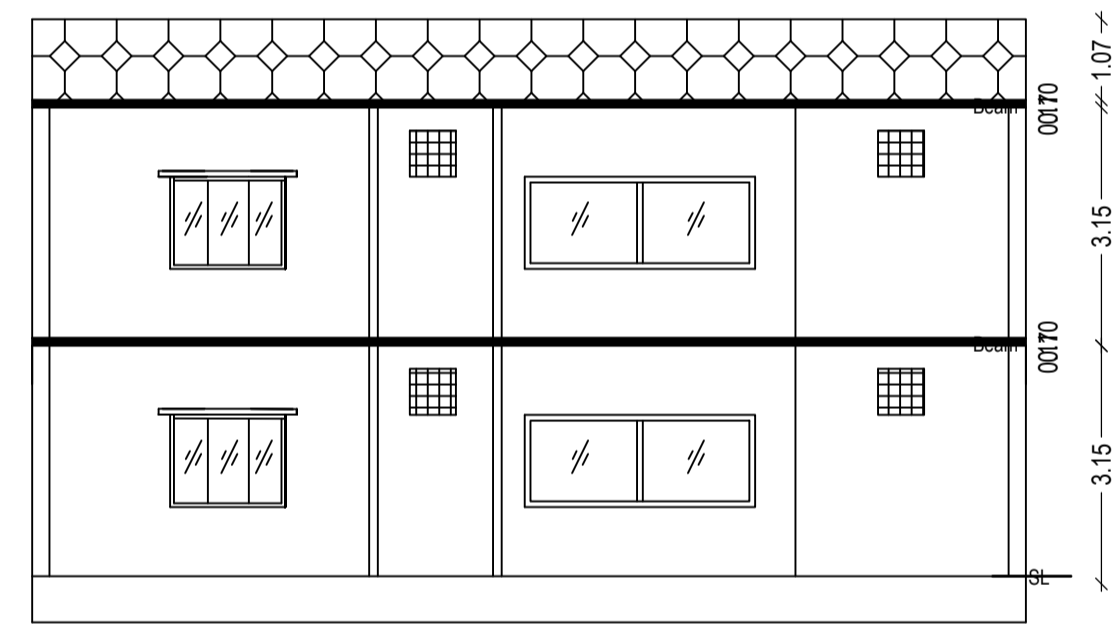

**SECTION ON YY**

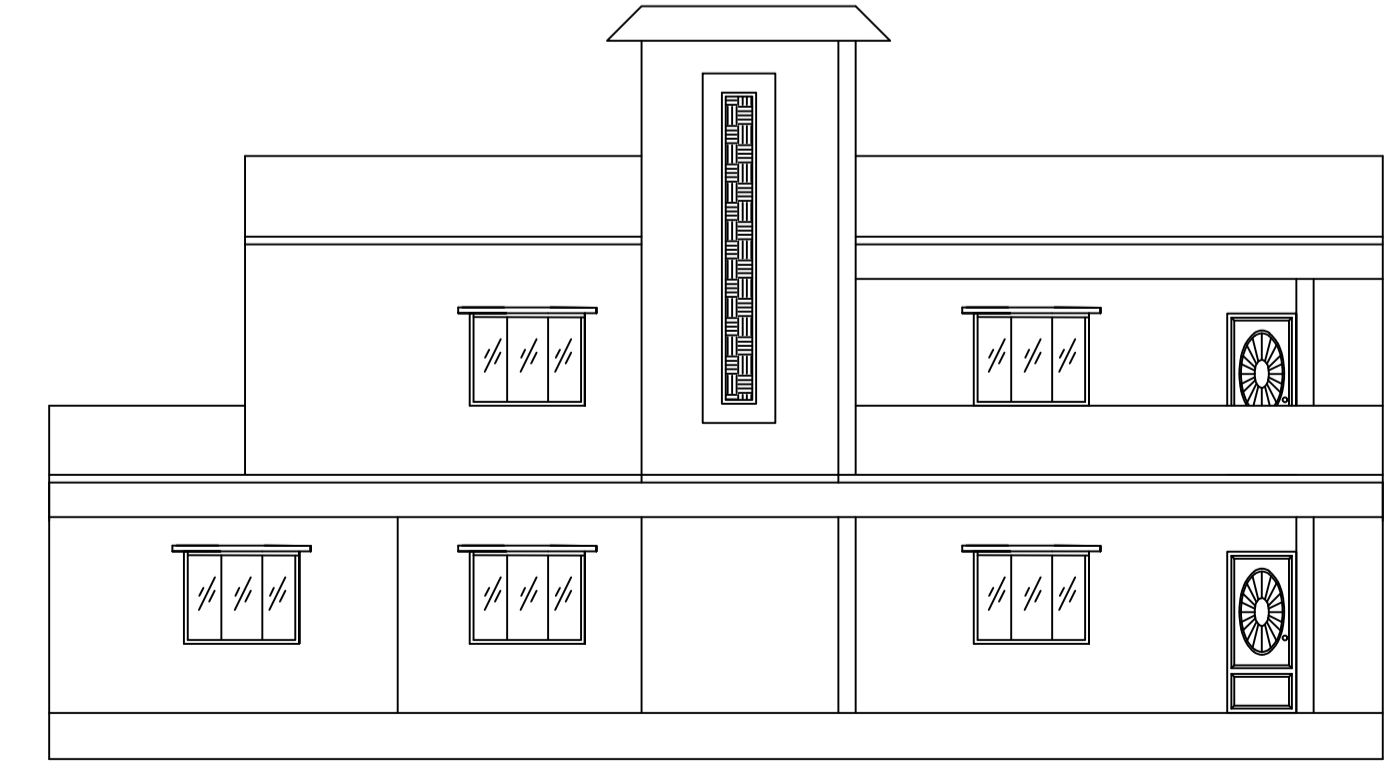

**FRONT ELEVATION**

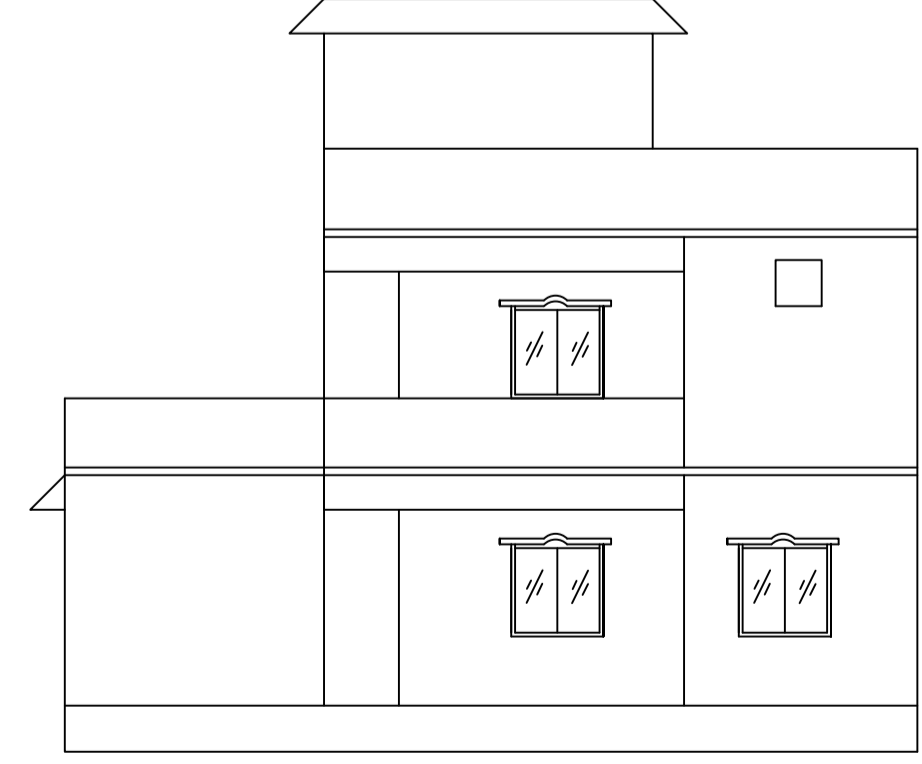

**RIGHT SIDE ELEVATION**

COLOR INDEX	
PLOT BOUNDARY	Black
ABUTTING ROAD	Red
PROPOSED CONSTRUCTION	Green
COMMON PLOT	Yellow
ROAD WIDENING AREA	Blue
EXISTING (To be retained)	Orange
EXISTING (To be demolished)	Light Blue

Buildingwise Floor FAR Details

Floor Name	Building Name A (A)		Total	
	Proposed Built Up Area (Sq.mt.)	Proposed FAR Area (Sq.mt.)	Total Proposed Built Up Area (Sq.mt.)	Total FAR Area (Sq.mt.)
Ground Floor	132.80	109.61	132.80	109.61
First Floor	104.51	104.51	104.51	104.51
Terrace Floor	0.00	0.00	0.00	0.00
<b>Total :</b>	<b>237.31</b>	<b>214.12</b>	<b>237.31</b>	<b>214.12</b>

Building USE/SUBUSE Details

Building Name	Building Use	Building SubUse	Building Structure
A (A)	Residential	Bungalow/ Dwelling / Non Apartment	Non-Highrise

FAR & Tenement Details (Table 4c-1)

Building	No. of Same Bldg	Total Built Up Area (Sq.mt.)	Deductions (Area in Sq.mt.)		Proposed FAR Area (Sq.mt.)	Total FAR Area (Sq.mt.)	Total Consumed Additional FAR Area (Sq.mt.)	Trmt (No.)
			Parking	Resi.				
A (A)	1	237.31	23.19	214.12	214.12	214.12	214.12	01
<b>Grand Total :</b>	<b>1</b>	<b>237.31</b>	<b>23.19</b>	<b>214.12</b>	<b>214.12</b>	<b>214.12</b>	<b>214.12</b>	<b>01</b>

LTP NAME AND SIGNATURE	STRUCTURAL ENG'S NAME AND SIGNATURE	BUILDER NAME AND SIGNATURE	DIGITAL SIGNATURE
Santosh DMC/ENG/0019/2016			

