

Project Title : MISS ROLLY

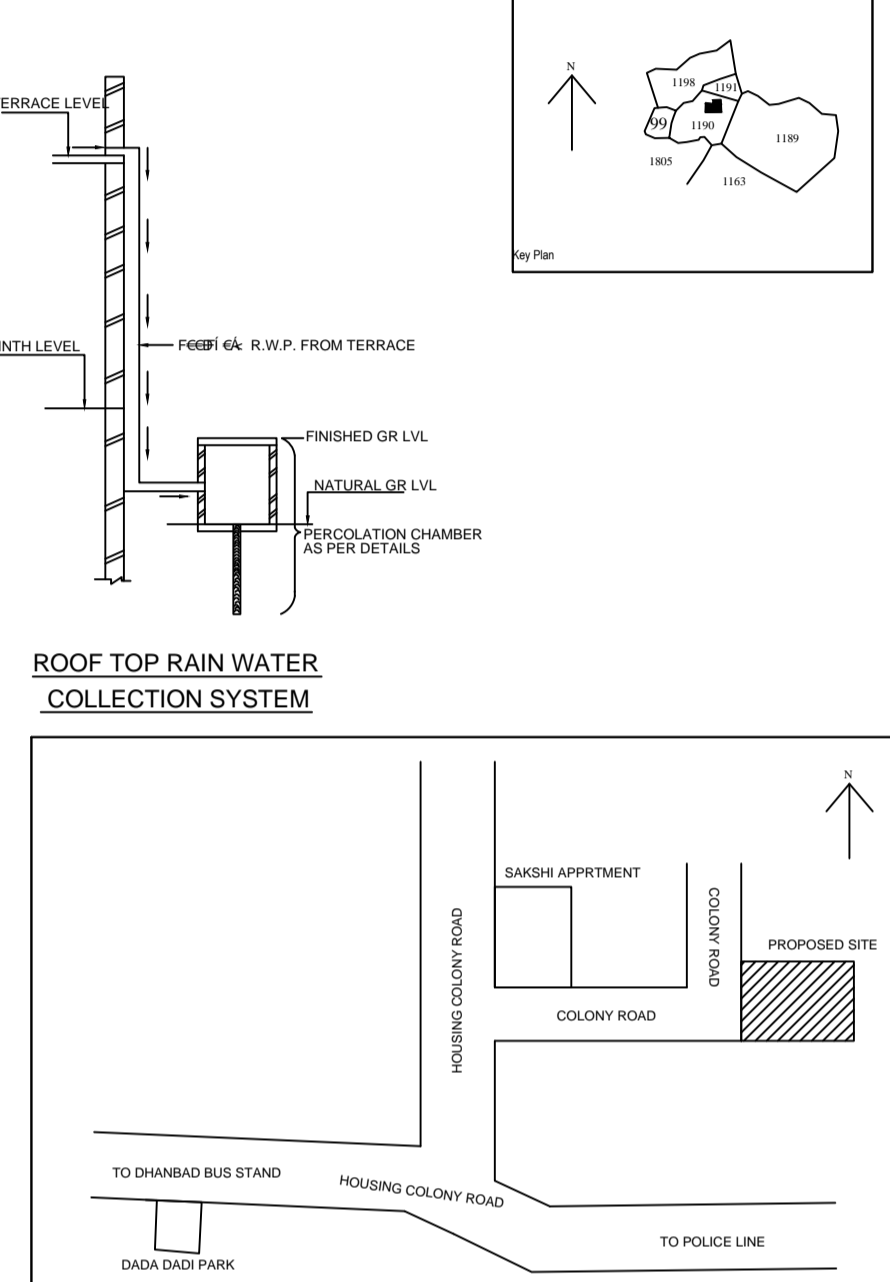
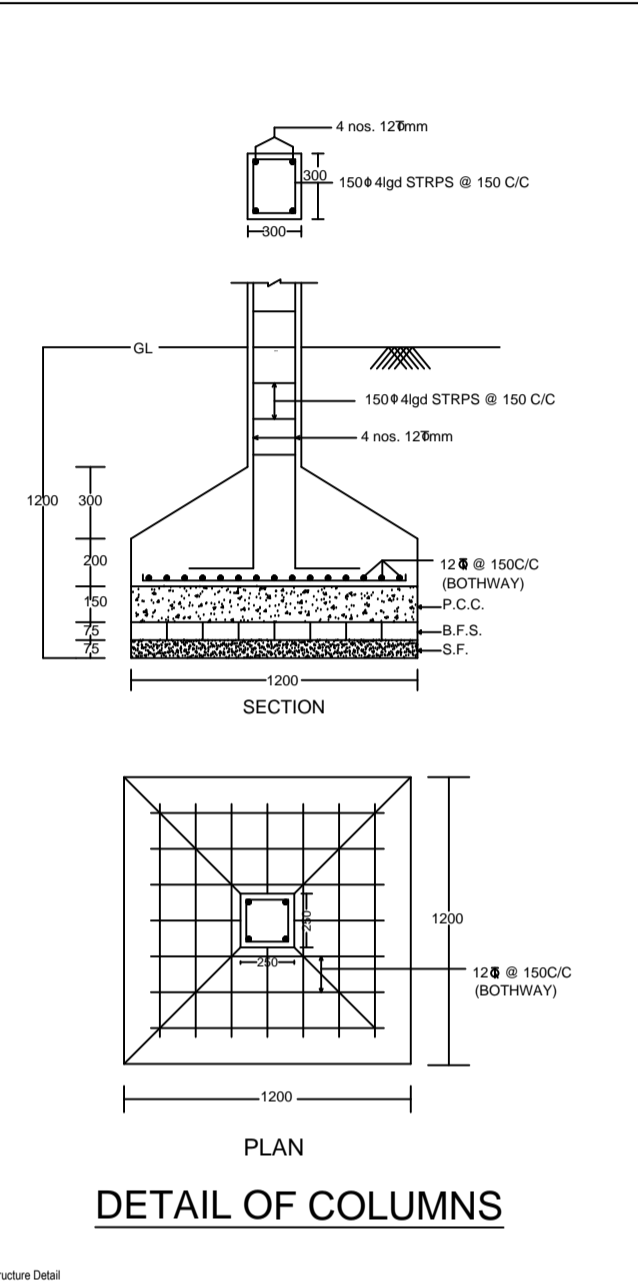
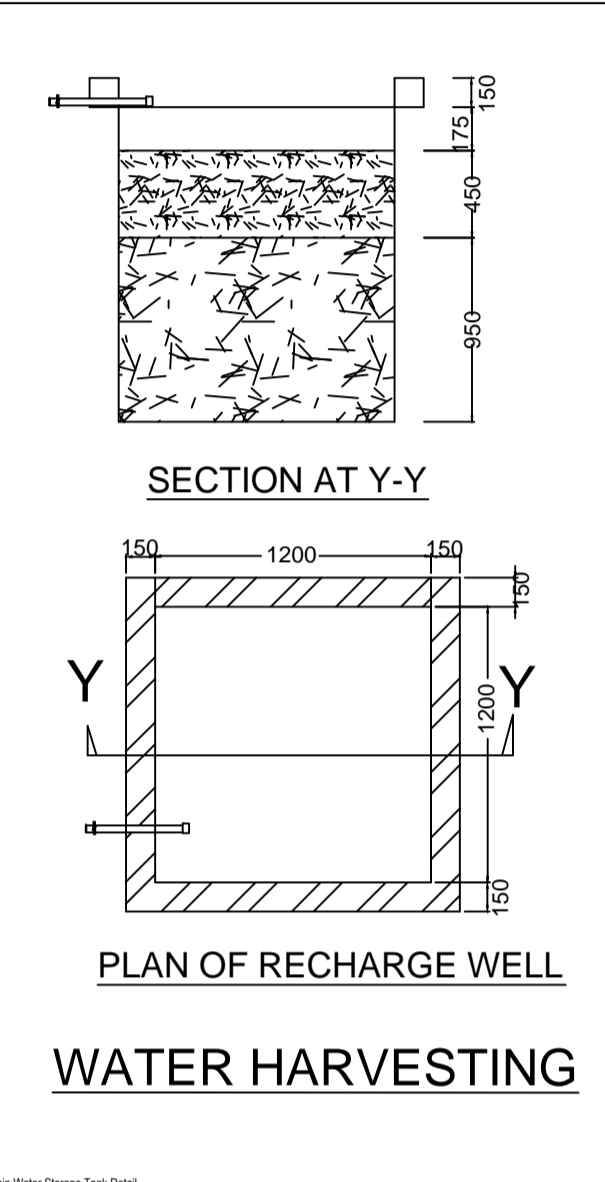
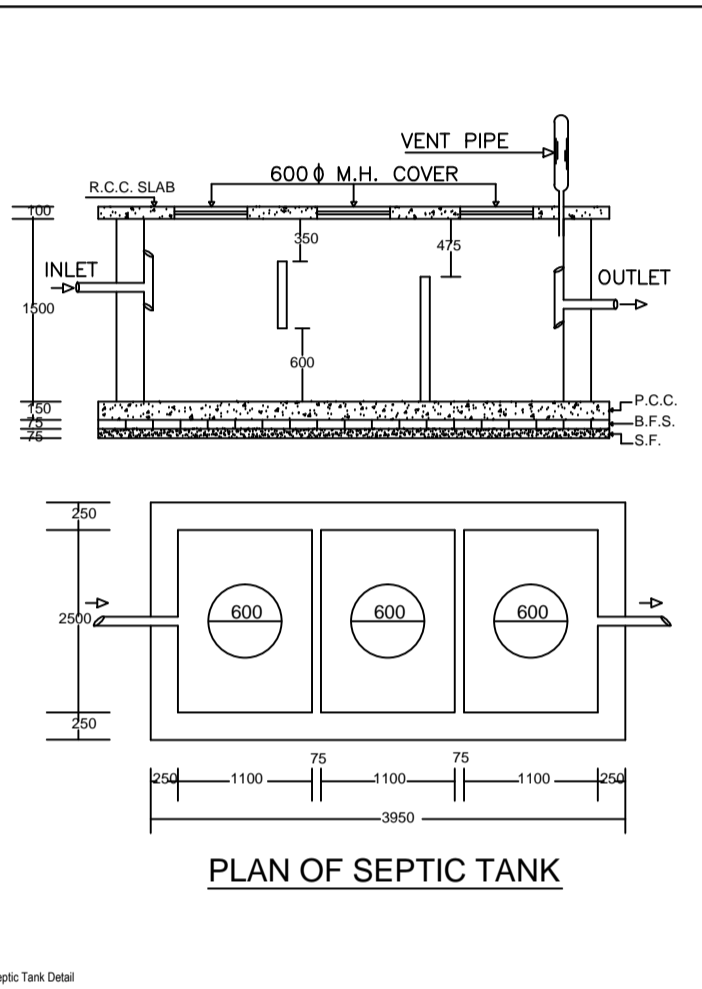
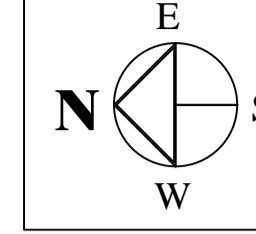
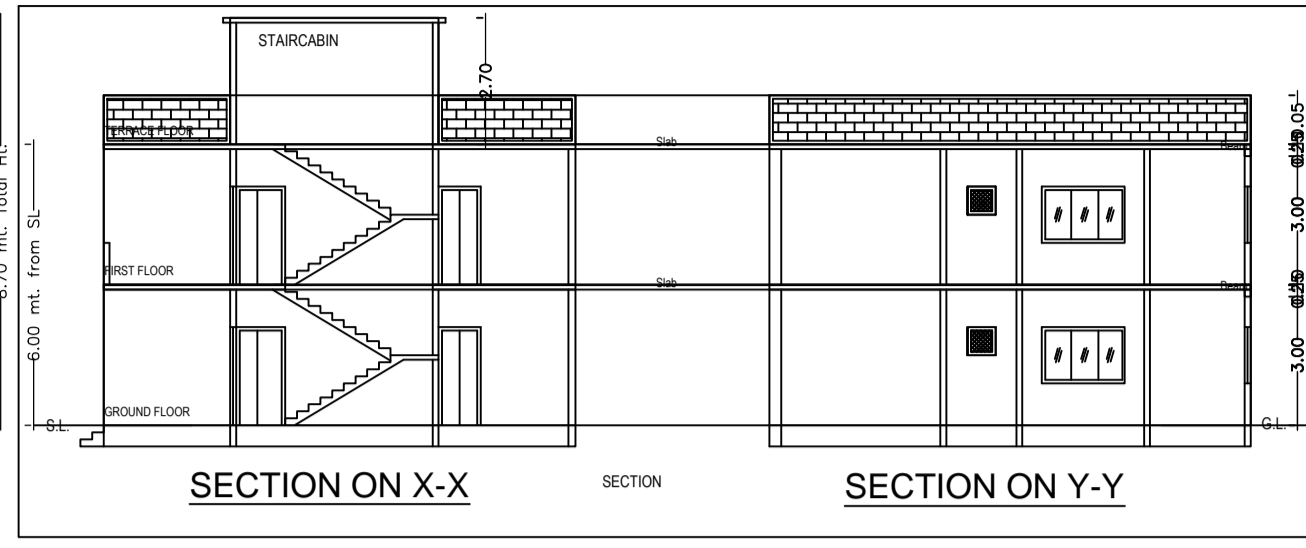
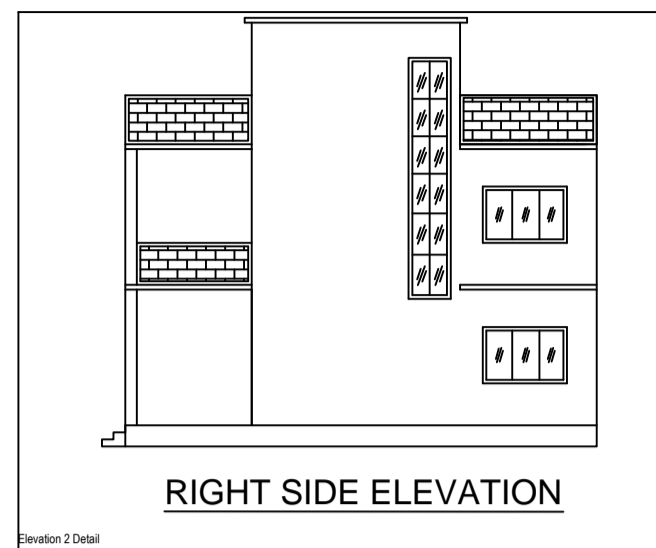
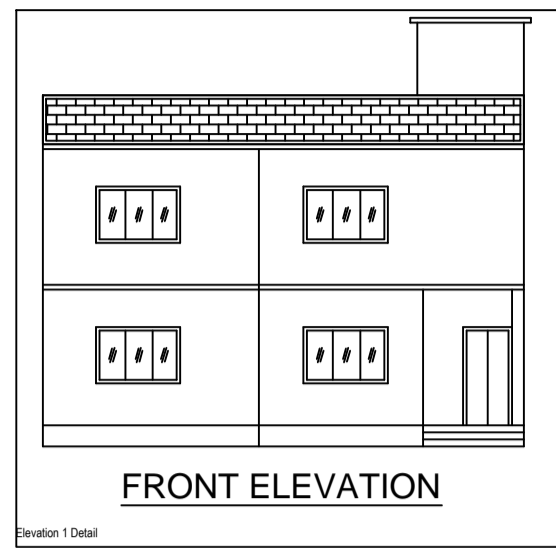

**BRIEF SPECIFICATION**  
 FOUNDATION----- CEMENT CONCRETE (1:1.5:3)  
 BRICK WORK IN FOUNDATION & SUPERSTRUCTURE  
 FIRST CLASS BRICK WORK IN CEMENT MORTAR (1:6)  
 D.P.C.-----25 D.P.C. IN CEMENT CONCRETE (1:2:4)  
 FLOOR-----25 I.P.S. OVER 75 P.C.C.  
 ROOF-----100 THK. R.C.C. ROOF (1:1.5:3)  
 LINTEL-----150 THK. R.C.C. LINTEL (1:1.5:3)  
 STAIRS----- RISE-- 150, TREAD-- 250

**DETAILS OF AREA**

TOTAL AREA (AS PER DEED)	133.59 SQM.
TOTAL AREA (AS PER SITE)	125.46 SQM.
GROUND FLOOR AREA	66.91 SQM.
FIRST FLOOR AREA	66.91 SQM.
TOTAL COVERED AREA	133.82 SQM.
% PLINTH AREA	53.33 %
FAR	1.07

**SCHEDULE**

D = 1.200X2.100	W = 1.800X1.200
D1 = 1.050X2.100	W2 = 2.400X1.200
D2 = 0.900X2.100	V = 0.600X0.600

**TITLE OF DRAWING**  
 PLAN OF PROPOSED RESIDENTIAL BUILDING OF MISS ROLLY D/O SRI RAJ KUMAR PRASAD SINGH OF RAJ RANJAN KUTIR, MANOHAR NAGAR, POLICE LINE, HIRAPUR, P.S. + DIST- DHANBAD, UNDER MOUZA - HIRAPUR, NO.- 07, KHATA NO.- 27, PLOT NO.- 1190 IN THE DIST. OF DHANBAD (JHARKHAND).

SIGNATURE OF OWNER

SIGNATURE OF ENGINEER

SCALE      ALL DIMENSION ARE IN METRE

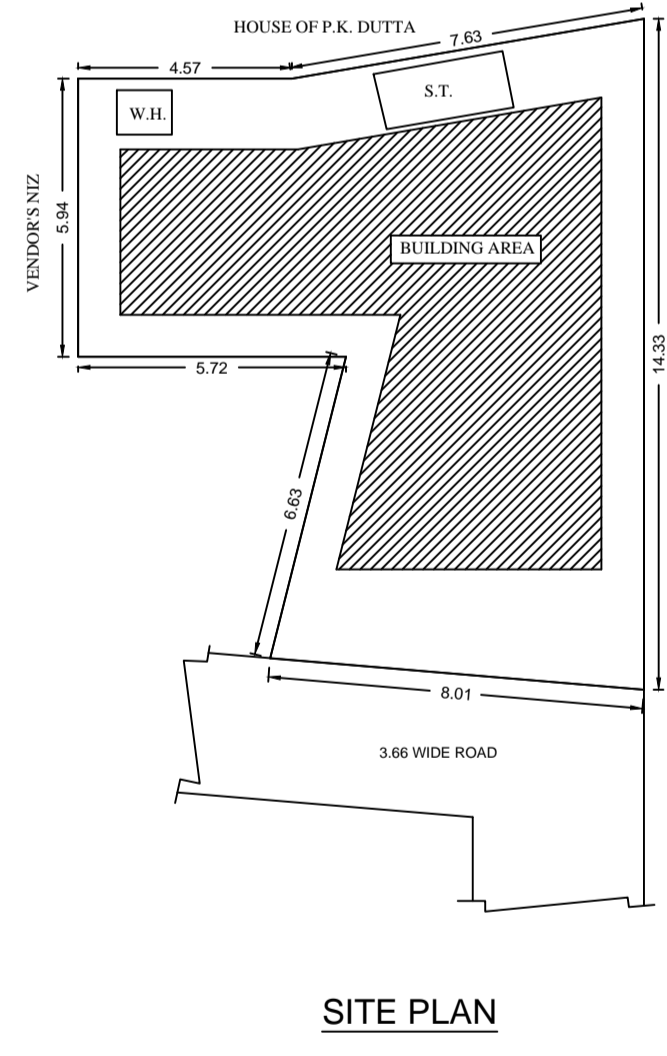
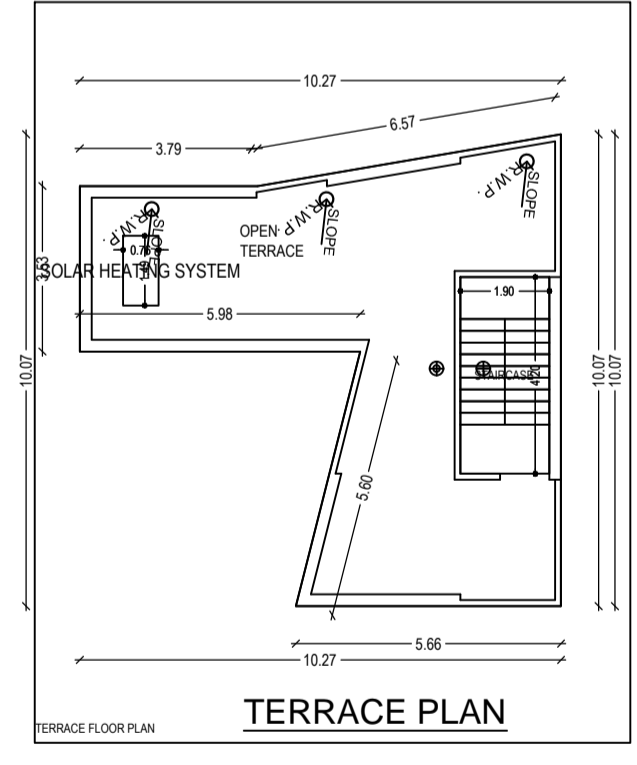
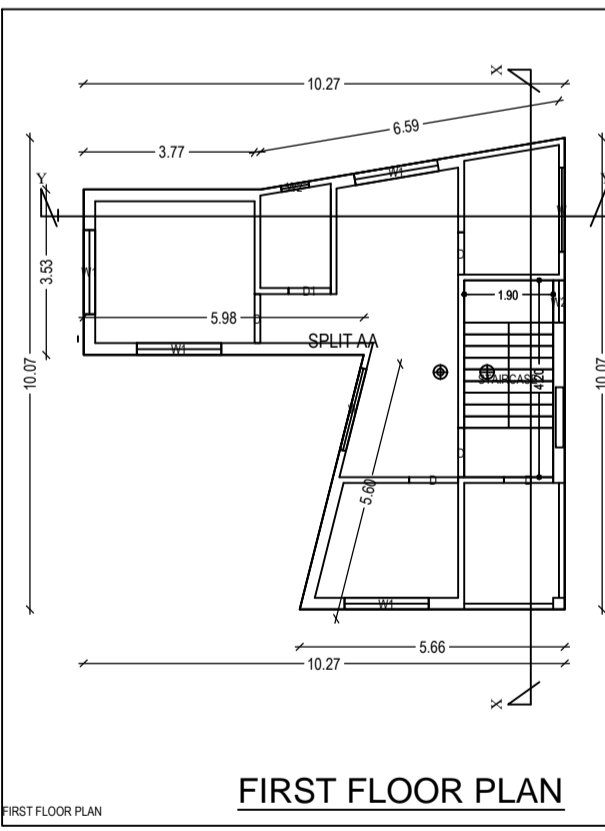
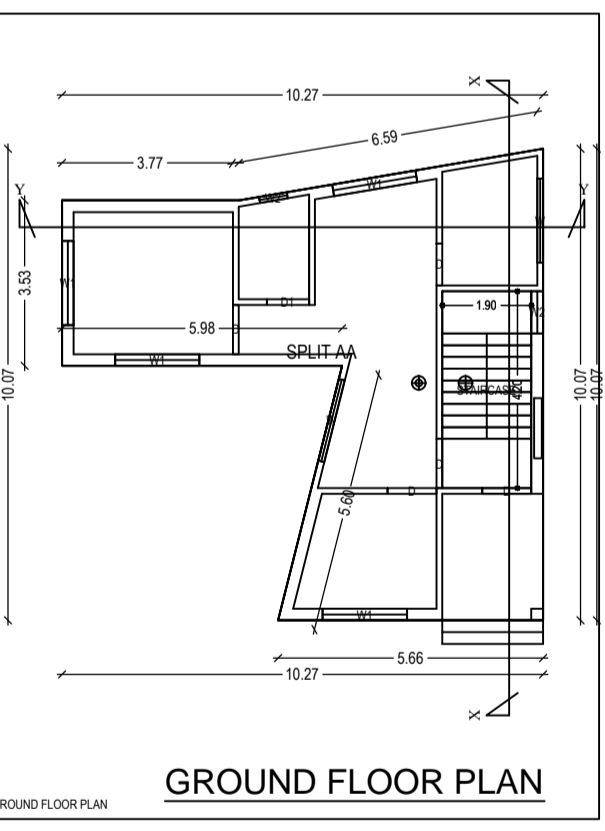
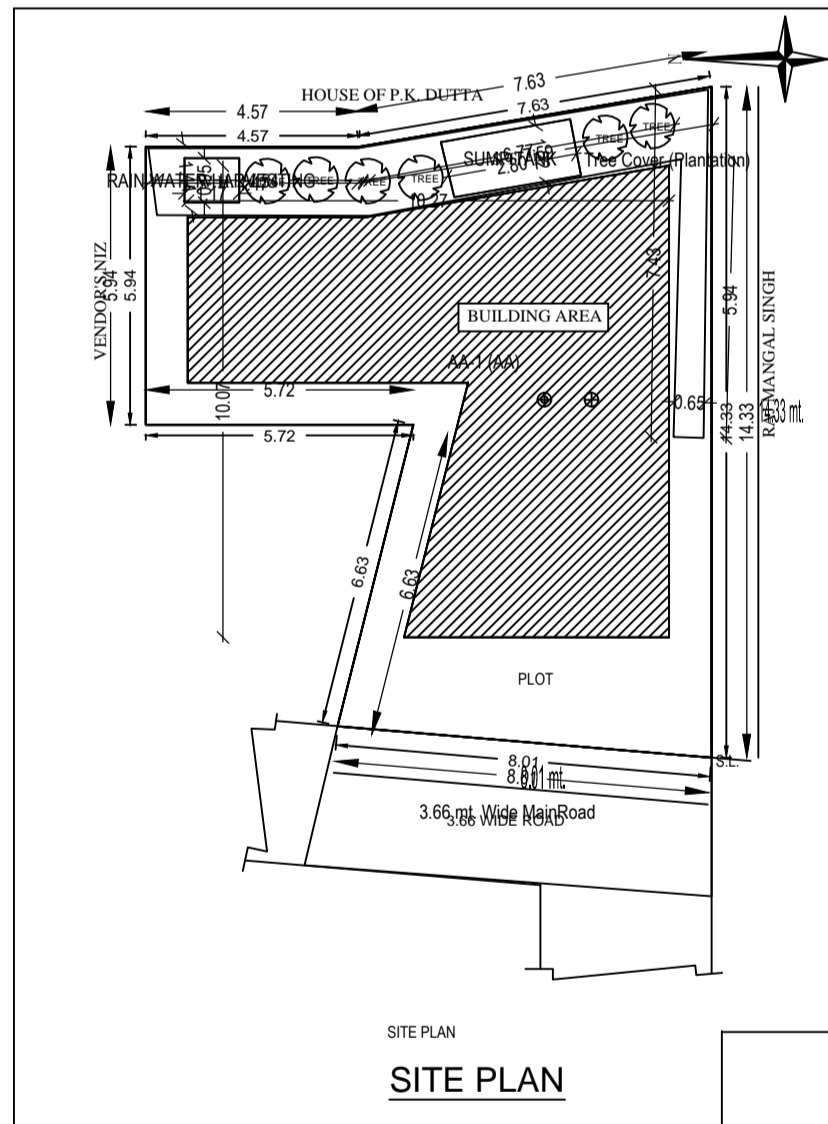

**Building\_AA (AA)**

Floor Name	Total Built Up Area (Sq.mt)	Proposed FAR Area (Sq.mt)	Total FAR Area (Sq.mt)	Terr (No.)
Ground Floor	66.91	66.91	66.91	01
First Floor	66.91	66.91	66.91	01
Terrace Floor	0.00	0.00	0.00	00
<b>Total</b>	<b>133.82</b>	<b>133.82</b>	<b>133.82</b>	<b>01</b>
Total Number of Same Buildings	1			
<b>Total</b>	<b>133.82</b>	<b>133.82</b>	<b>133.82</b>	<b>01</b>

**SCHEDULE OF JOINERY:**

BUILDING NAME	NAME	LENGTH	HEIGHT	NOSE
AA (AA)	D	0.80	2.10	02
AA (AA)	D1	0.80	2.10	02
AA (AA)	D	1.00	2.10	08
<b>Total</b>	-	-	-	<b>12</b>

**SCHEDULE OF JOINERY:**

BUILDING NAME	NAME	LENGTH	HEIGHT	NOSE
AA (AA)	WE	0.60	1.20	02
AA (AA)	WE	0.90	1.20	02
AA (AA)	W	1.80	1.20	04
AA (AA)	W1	1.80	1.20	08
<b>Total</b>	-	-	-	<b>16</b>

**Unit/BUA Table for Building\_AA (AA)**

FLOOR	Name	Unit/BUA Type	Unit/BUA Area	Carpet Area	No. of Rooms	No. of Tenement
GROUND FLOOR	SPLIT AA	FLAT	133.81	133.37	6	1
<b>Total</b>	-	-	<b>133.81</b>	<b>133.37</b>	<b>12</b>	<b>1</b>

**AREA DETAIL:**

AREA OF PLOT (Minimum)	(A)	52.41	125.46
Nett Plot Area (Gross Plot Area - Deduction from Gross Plot Area)	(A-Deductions)		125.46
Deductions for Balance Plot Area (from Gross Plot Area)			
COF Area		20.00	20.00
Yield		20.00	20.00
Balance Plot Area (Nett Plot Area - (Reproducible/Amenity spaces))	(A-Deductions)		104.87
Plot Area for Coverage (Nett Plot Area)	(A-Deductions)		125.46
Plot Area for FSI (Nett Plot Area - (Health/Safety Area))	(A-Deductions)		125.46

**COVERAGES CHECK**

Proposed Coverage Area (133.33%)	86.91
Permitted Coverage Area (133.33%)	86.91

**FAR CHECK**

Proposed FAR of Fm	133.82
Permitted FAR of Fm	133.82

**BUILD UP AREA CHECK**

Total Proposed Built Up Area	133.82
Permitted Built Up Area	133.82

**ARCHT ENGRG(SUPERSVISOR) (Regd)** OWNER

**DEVELOPMENT AUTHORITY** LOCAL BODY

**COLOR INDEX**

Color Index:  
 MARGIN DETAIL:

Building/Work Name	Road Name	Front Margin	Rear Margin	Side Margin	Clear Margin
AA (AA)	1.00 M Wide Road	2.01	1.51	0.90	0.91

**FAR & Tenement Details (Table 4c-1)**

Building	No. of Same Bldg	Total Built Up Area (Sq.mt)	Proposed FAR Area (Sq.mt)	Total FAR Area (Sq.mt)	Terr (No.)
AA (AA)	1	133.82	133.82	133.82	01
<b>Total</b>	<b>1</b>	<b>133.82</b>	<b>133.82</b>	<b>133.82</b>	<b>01</b>