

Proposal Basic Information

Proposal File No.	DMC/BP/0202/W17/2022
Owner Name	MD.FIROZ ANSARI AND SHABNAM PARWEEN
Khata No	591(NEW)/04(OLD)
Plot No	1063(NEW)/1458(OLD)
Village Name	Panderpala
Use	Residential
SubUse	Bungalow/ Dwelling / Non Apartment

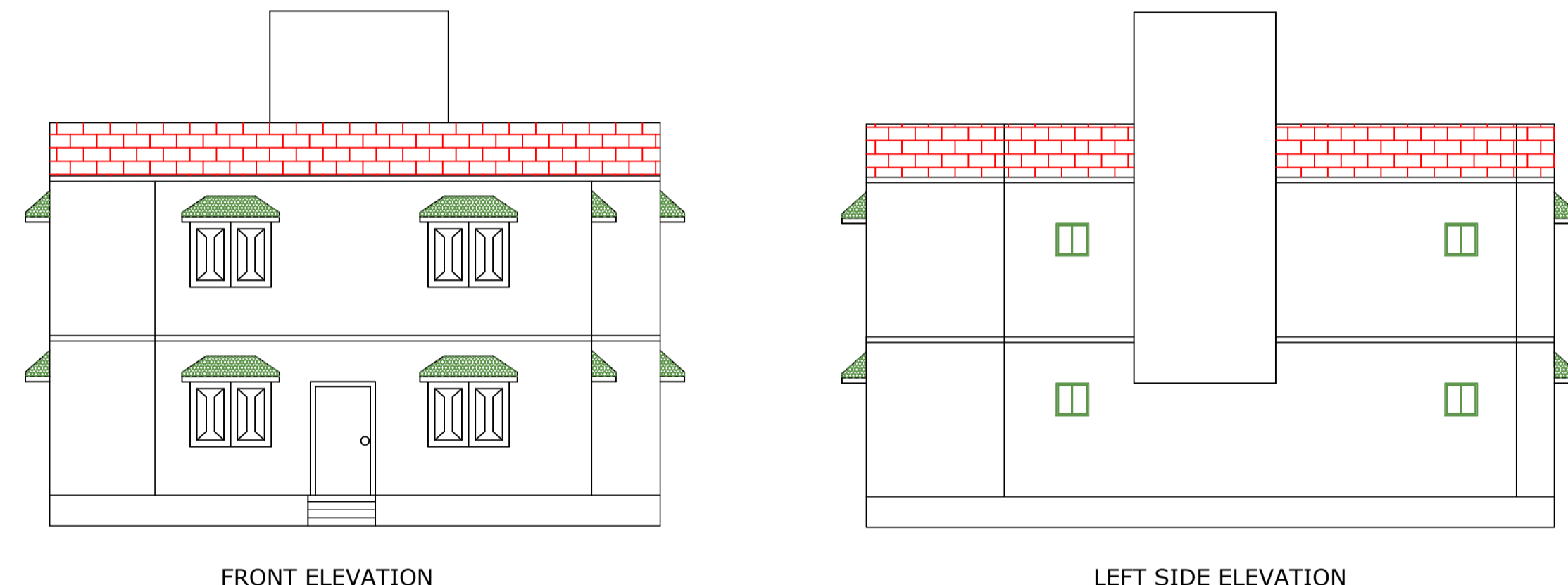
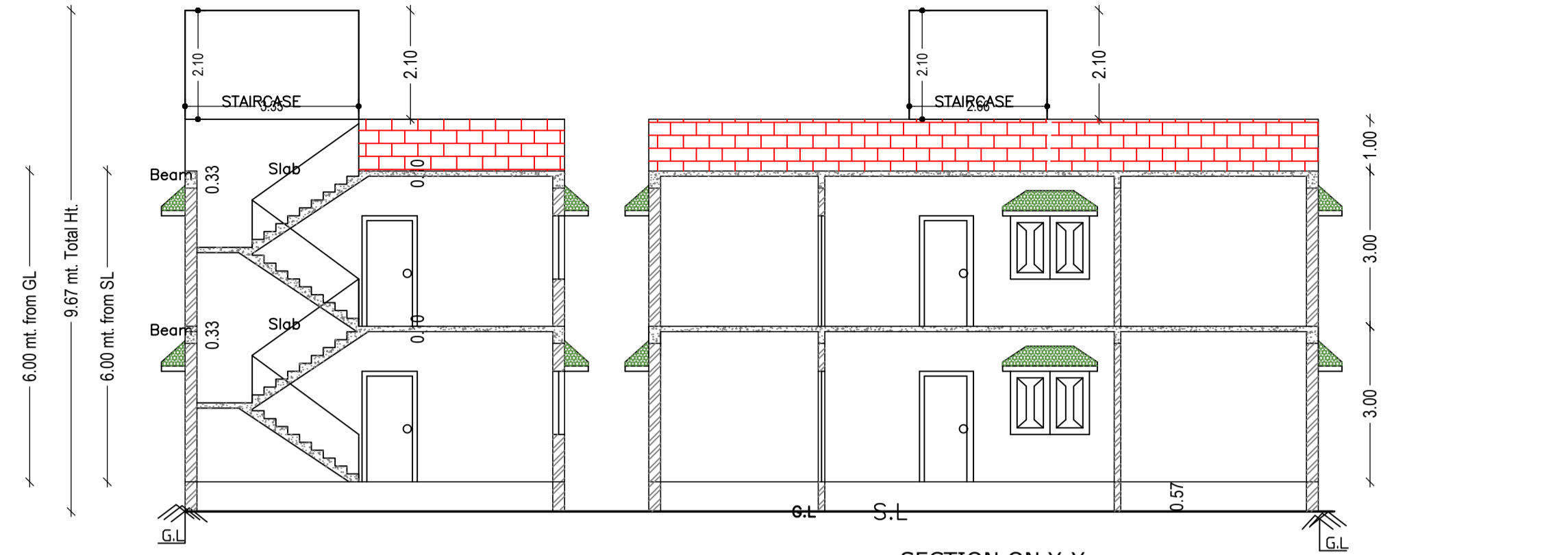
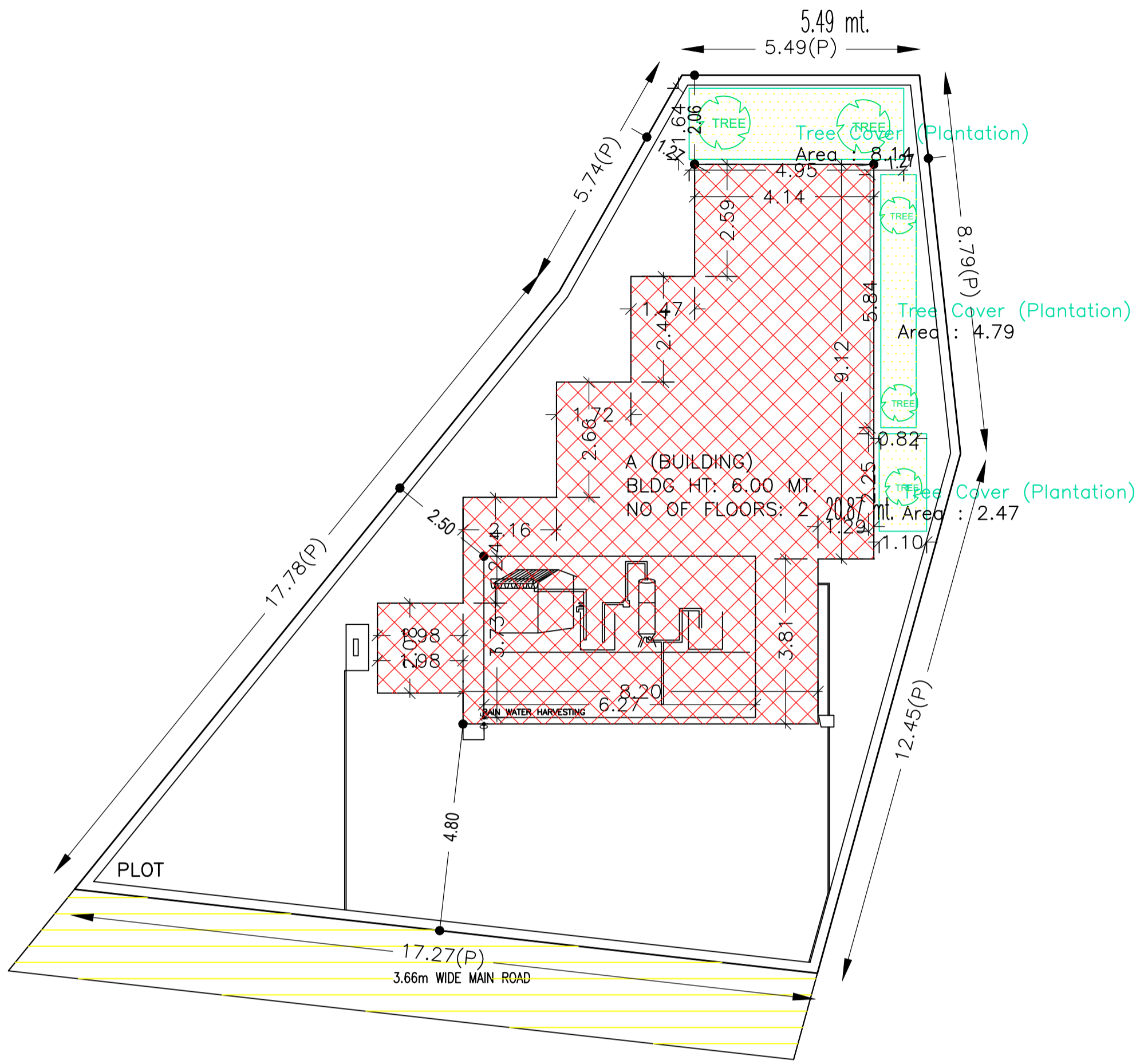

AREA STATEMENT	VERSION NO.: 1.0.62
DHANBAD MUNICIPAL CORPORATION	VERSION DATE: 16/10/2020
PROJECT DETAIL:	
Region: JHARKHAND URBAN LOCAL BODIES	Plot Use: Residential
District: DHANBAD	Plot SubUse: Bungalow/ Dwelling / Non Apartment
Authority: DHANBAD MUNICIPAL CORPORATION	Plot/Nearby/Religious/Structure: NA
Inward_No: DMC/BP/0202/W17/2022	Plot/SubPlot No: 1063(NEW)/1458(OLD)
Application Type: General Proposal	North: Plot No. - IFFAT FIRDAUSI
Project Type: Building Permission	South: Plot No. - GAYYUM ANSARI
Nature of Development: New	East: Road Width - 3.9
Location of Development Area: Old Area	West: Plot No. - MD.FAROOQ ANSARI
AREA DETAILS:	
AREA OF PLOT (Minimum)	(A) 243.64 SQ.MT.
NET AREA OF PLOT (Gross Plot Area - Deduction from Gross Plot area)	(A-Deductions) 243.64
Deduction for Balance Plot Area (from Gross Plot Area)	
Common Plot	15.40
Total	15.40
BALANCE AREA OF PLOT (Net Plot Area - Recreational/Amenity space)	(A-Deductions) 228.23
PLOT AREA FOR COVERAGE (Net Plot Area)	(A-Deductions) 243.64
Plot Area for FAR (Net Plot Area + Road Widening Area)	(A-Deductions) 243.64
COVERAGE CHECK	
Permissible Coverage area ( 60.00 % )	146.18
Proposed Coverage Area ( 38.10 % )	92.82
Total Prop. Coverage Area ( 38.10 % )	92.82
Balance coverage area ( 21.90 % )	53.36
FAR CHECK	
Perm. FAR Area ( 1.50 )	365.46
Total Perm. FAR area	365.46
Residential FAR	185.64
Proposed FAR Area	185.64
Total Proposed FAR Area	185.64
Consumed FAR (Factor)	0.76
Balance FAR Area	179.82
BUILT UP AREA CHECK	
Total Proposed BuiltUp Area	185.64
ARCHITECT (Regd)	SYED NAQUE ALAM
ENGINEER (Regd)	
SUPERVISOR (Regd)	
OWNER (Regd)	MD FIROZ ANSARI AND SHABNAM PARWEEN
DEVELOPMENT AUTHORITY	LOCAL BODY

SITE PLAN

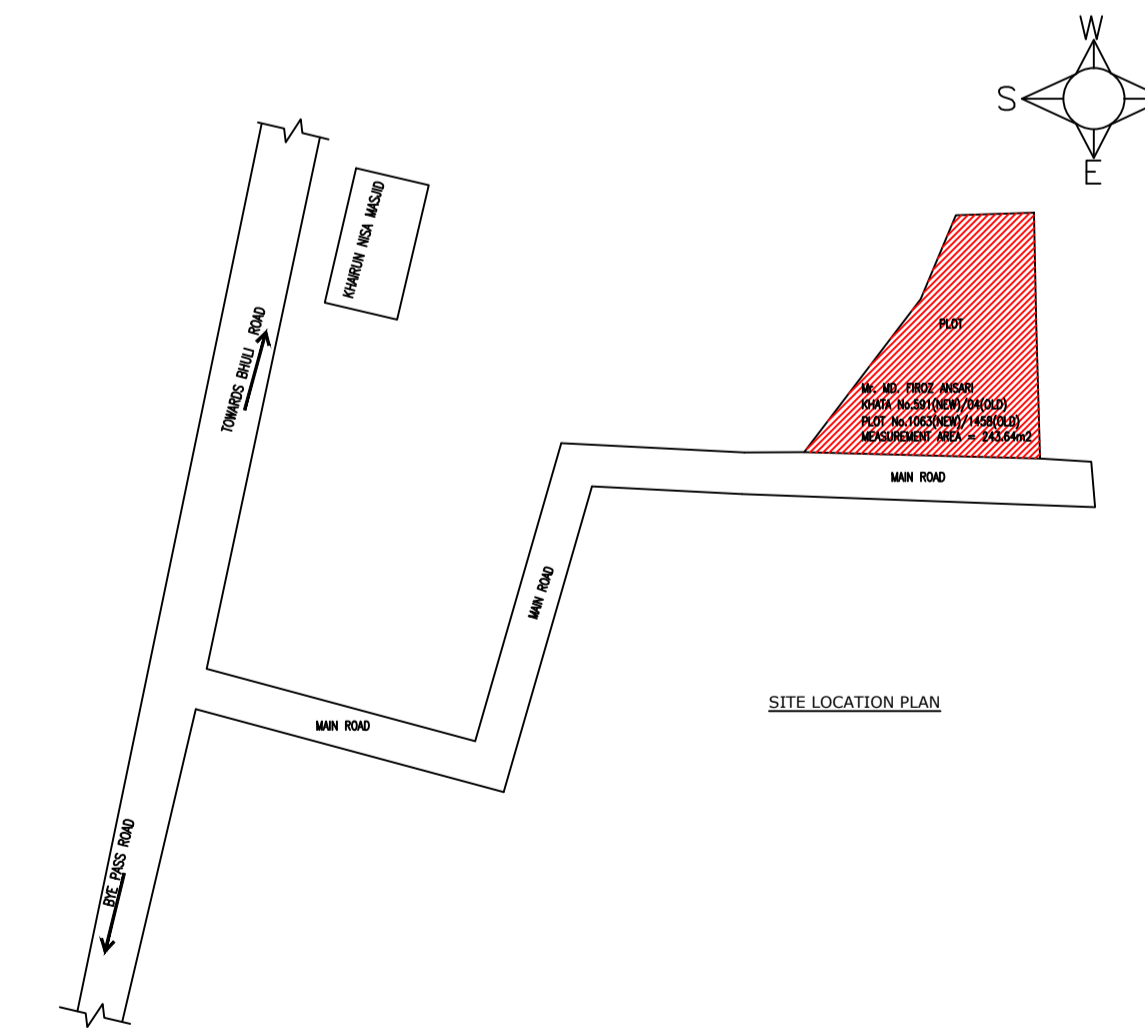
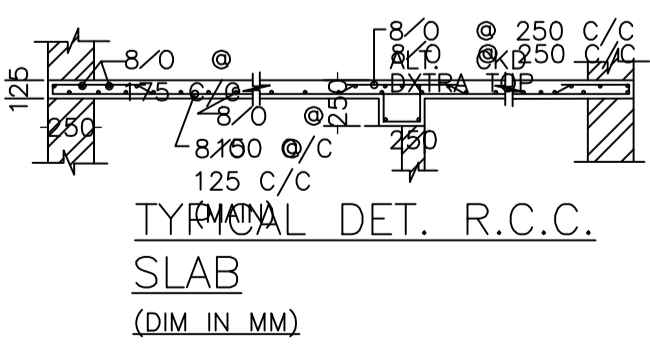
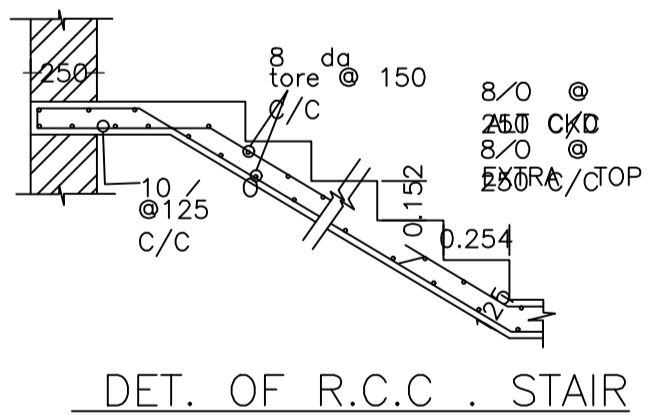
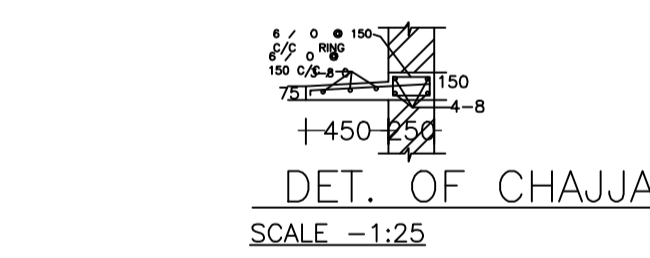
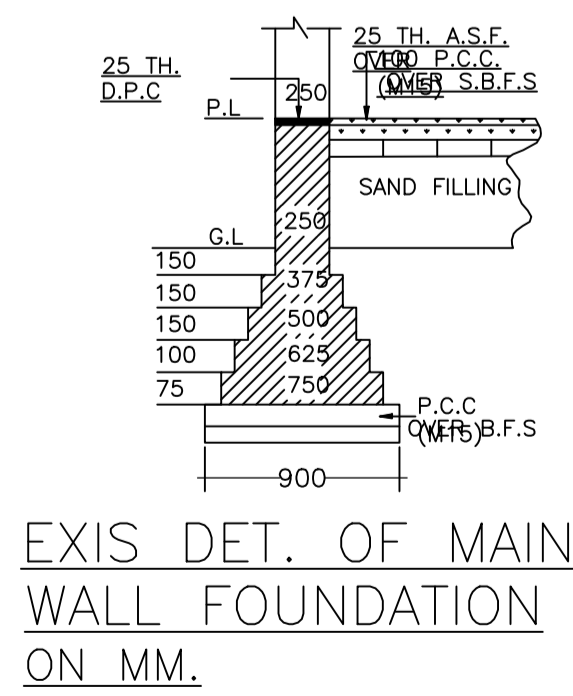
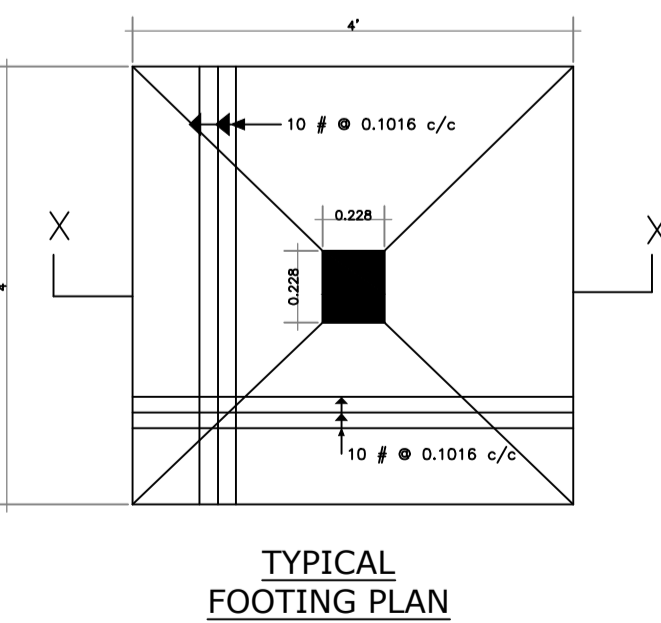
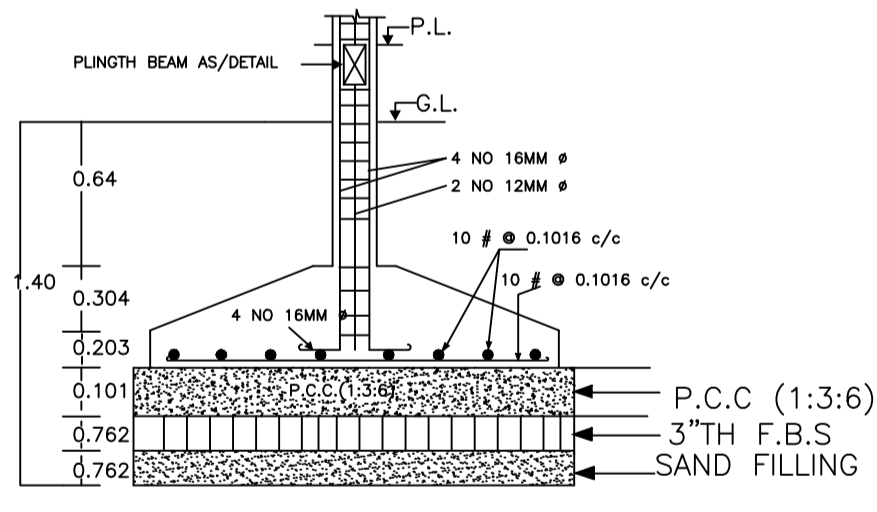
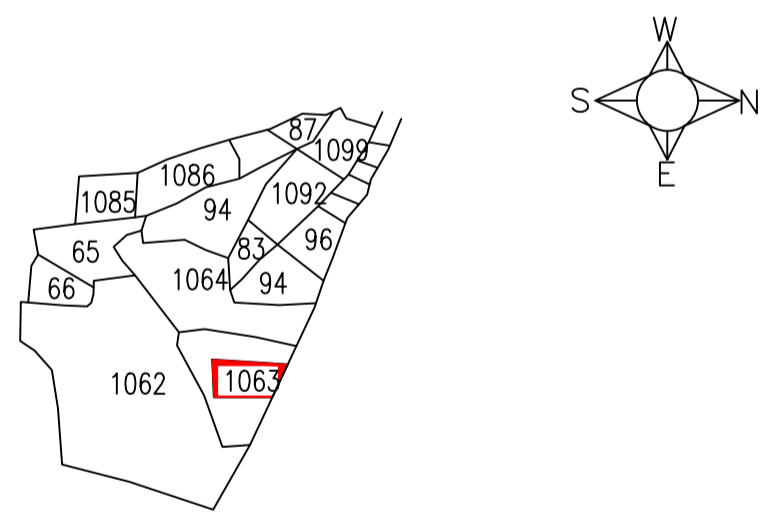

COLOR INDEX	
PLOT BOUNDARY	Black
ABUTTING ROAD	Red
PROPOSED CONSTRUCTION	Green
COMMON PLOT	Yellow
ROAD WIDENING AREA	Blue
EXISTING (To be retained)	Light Blue
EXISTING (To be demolished)	Dark Blue

SCHEDULE OF DOOR:

BUILDING NAME	NAME	LENGTH	HEIGHT	NOS
A (BUILDING)	D	0.91	2.10	06
A (BUILDING)	D1	1.07	2.10	08

SCHEDULE OF WINDOW/VENTILATION:

BUILDING NAME	NAME	LENGTH	HEIGHT	NOS
A (BUILDING)	V	0.61	1.20	04
A (BUILDING)	W	1.83	1.20	12

UnitBUA Table for Building :A (BUILDING)

FLOOR	Name	UnitBUA Type	UnitBUA Area	Carpet Area	No. of Rooms	No. of Tenement
GROUND FLOOR PLAN	SPLIT SPLIT	FLAT	166.01	161.53	9	1
FIRST FLOOR PLAN	SPLIT SPLIT	FLAT	0.00	0.00	9	0
Total:	-	-	166.01	161.53	18	1

FAR & Tenement Details (Table 4c-1)

Building	No. of Same Bldg	Total Built Up Area (Sq.mt.)	Proposed FAR Area (Sq.mt.) Res.	Total FAR Area (Sq.mt.)	Total Consumed Additional FAR Area (Sq.mt.)	Tnmt (No.)
A (BUILDING)	1	185.64	185.64	185.64	185.64	01
Grand Total :	1	185.64	185.64	185.64	185.64	01

Buildingwise Floor FAR Details

Floor Name	Building Name		Total	
	Proposed Built Up Area (Sq.mt.)	Proposed FAR Area (Sq.mt.)	Total Proposed Built Up Area (Sq.mt.)	Total FAR Area (Sq.mt.)
Ground Floor	92.82	92.82	92.82	92.82
First Floor	92.82	92.82	92.82	92.82
Terrace Floor	0.00	0.00	0.00	0.00
Total :	185.64	185.64	185.64	185.64

Building USE/SUBUSE Details

Building Name	Building Use	Building SubUse	Building Structure
A (BUILDING)	Residential	Bungalow/ Dwelling / Non Apartment	Non-Highrise

Building :A (BUILDING)

Floor Name	Total Built Up Area (Sq.mt.)	Proposed FAR Area (Sq.mt.) Res.	Total FAR Area (Sq.mt.)	Total Consumed Additional FAR Area (Sq.mt.)	Tnmt (No.)
Ground Floor	92.82	92.82	92.82	92.82	01
First Floor	92.82	92.82	92.82	92.82	00
Terrace Floor	0.00	0.00	0.00	0.00	00
Total :	185.64	185.64	185.64	185.64	01

LTP NAME AND SIGNATURE	STRUCTURAL ENG'S NAME AND SIGNATURE	BUILDER NAME AND SIGNATURE	DIGITAL SIGNATURE
SYED NAQUE ALAM DMC/ENG/0010/2017			

Proposal Basic Information	
Proposal File No.	DMC/BI/0202/W17/2022
Owner Name	MD.FIROZ ANSARI AND SHABNAM PARWEEN
Khata No	591(NEW)/04(OLD)
Plot No	1063(NEW)/1458(OLD)
Village Name	Panderpala
Use	Residential
SubUse	Bungalow/ Dwelling / Non Apartment

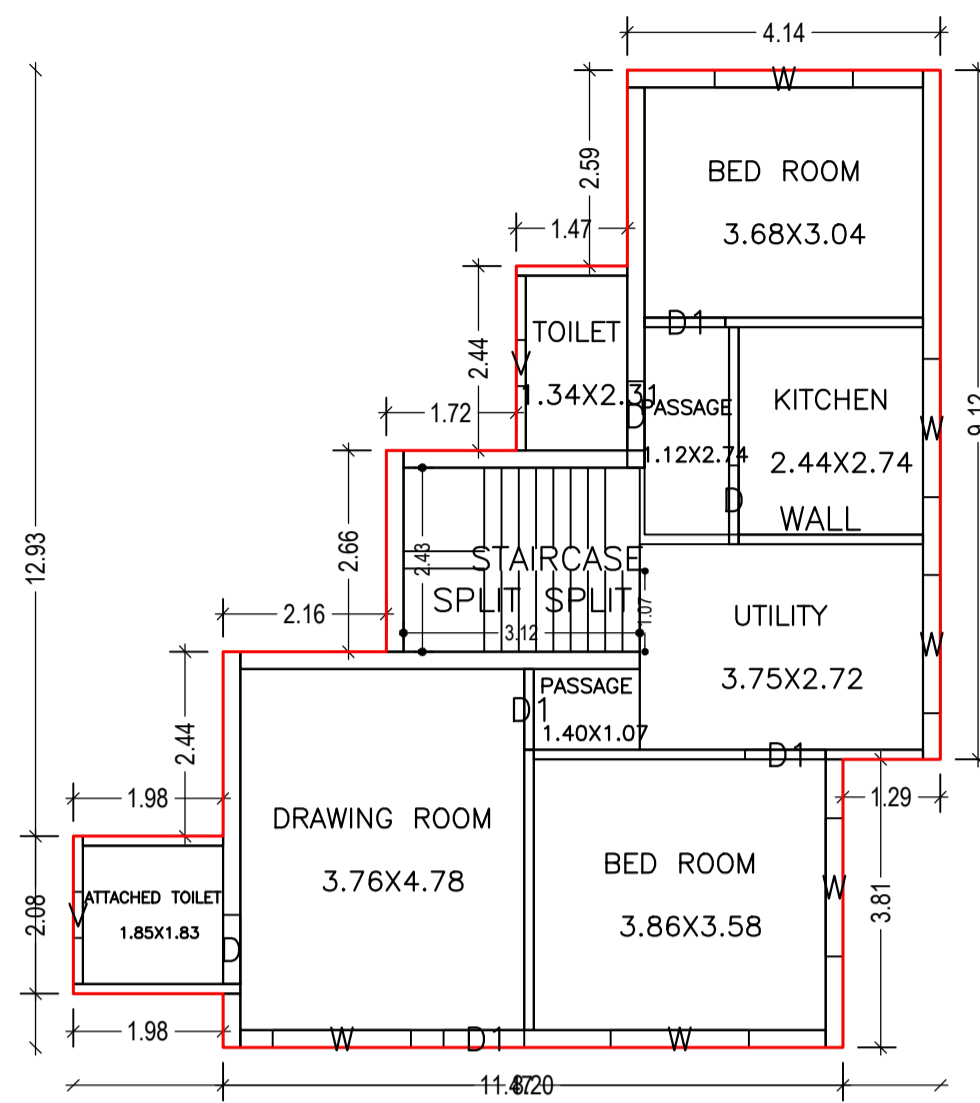

GROUND FLOOR PLAN  
(Proposed)  
(SCALE 1:100)

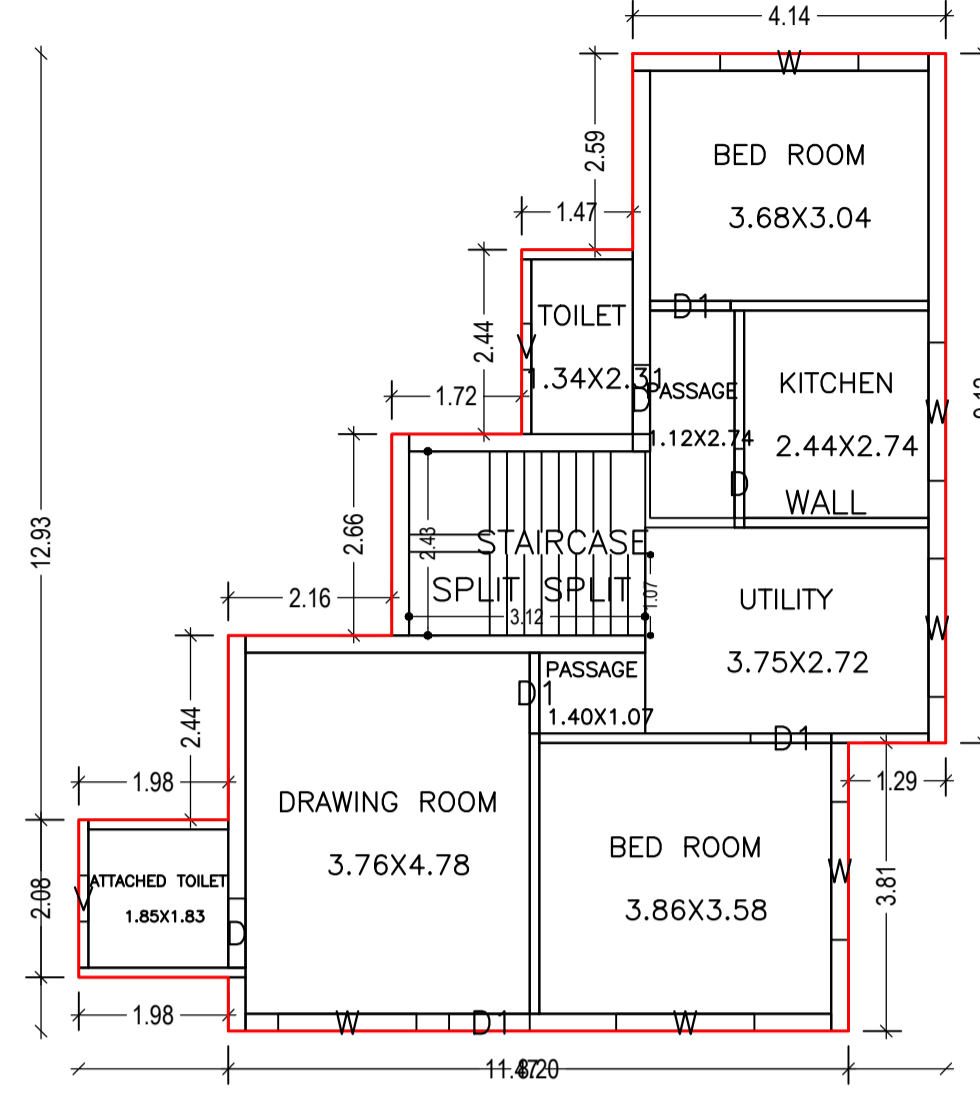

FIRST FLOOR PLAN  
(Proposed)  
(SCALE 1:100)

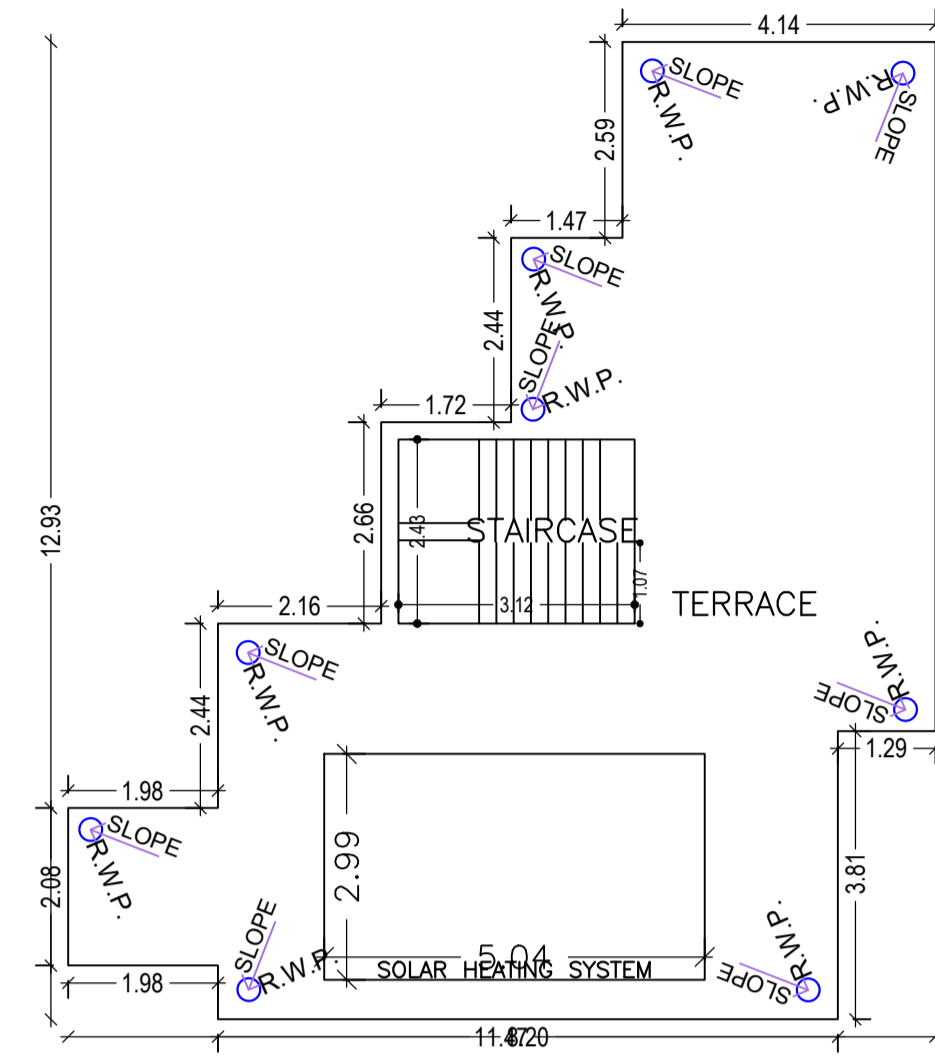

TERRACE FLOOR PLAN  
(SCALE 1:100)

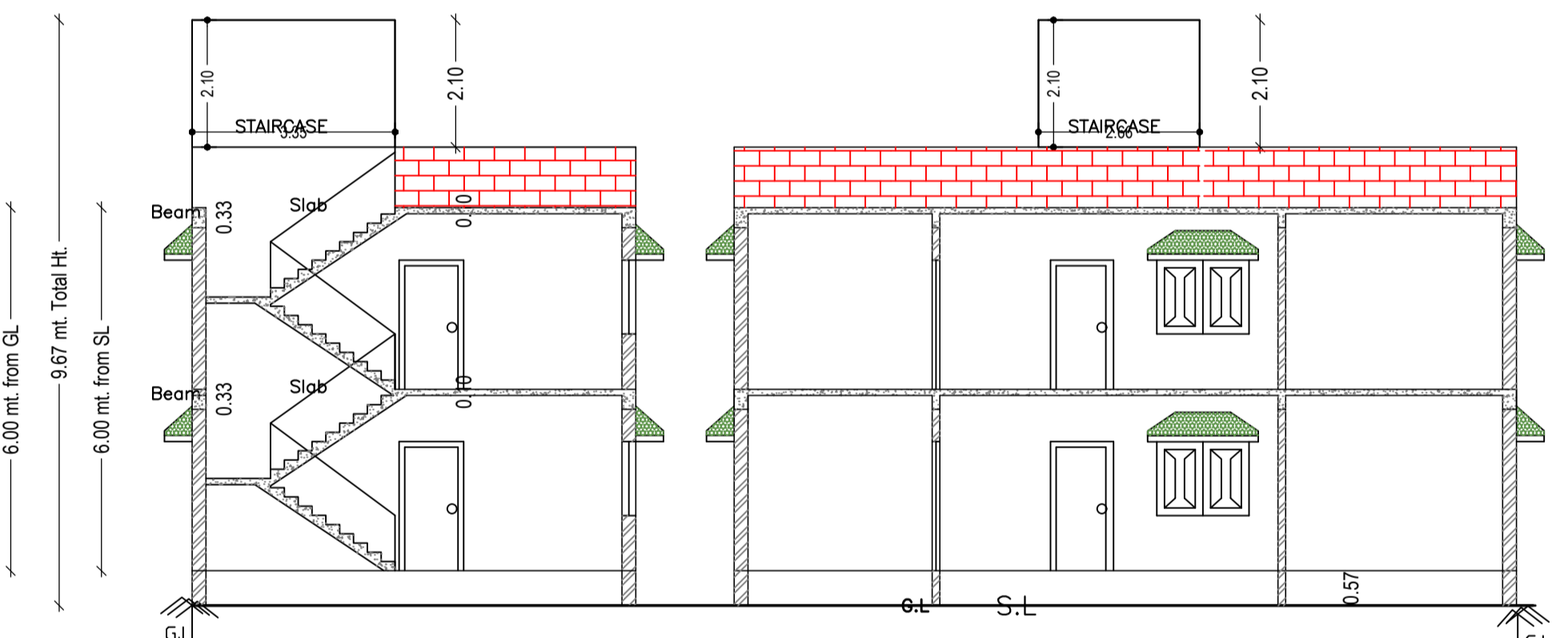
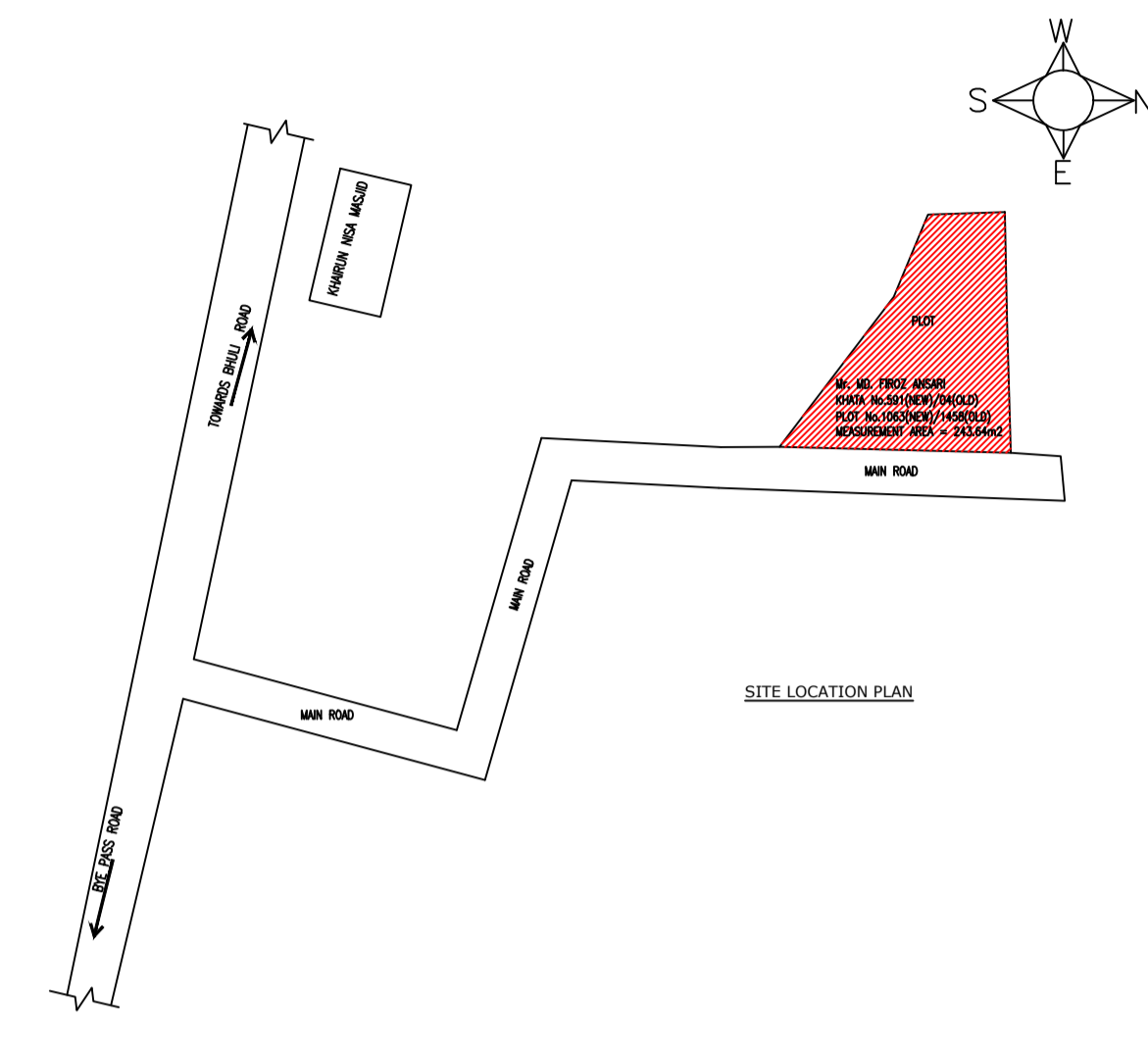

SECTION ON X-X

SECTION ON Y-Y

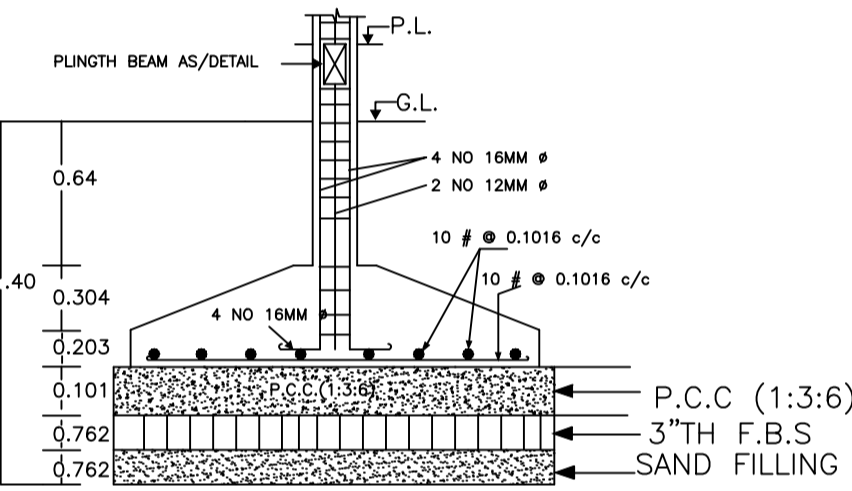

SECTION AT X-X  
DETAIL OF COLUMN FOUNDATION

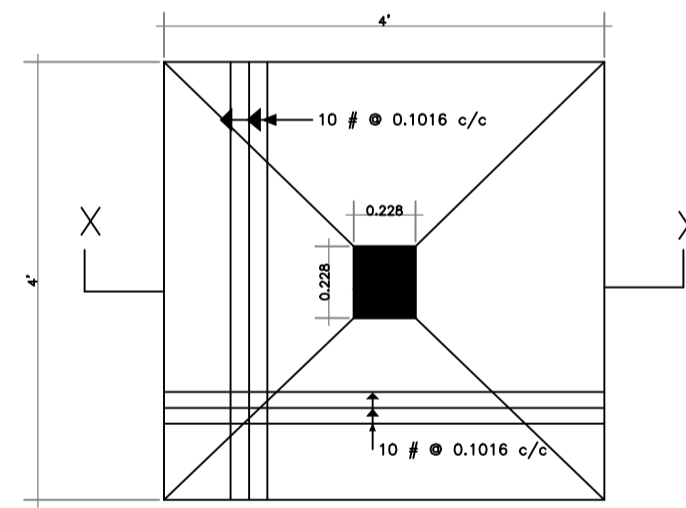

TYPICAL  
FOOTING PLAN

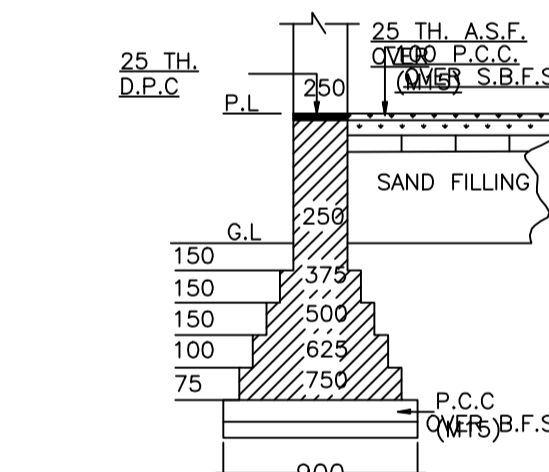

EXIS DET. OF MAIN  
WALL FOUNDATION  
ON MM.

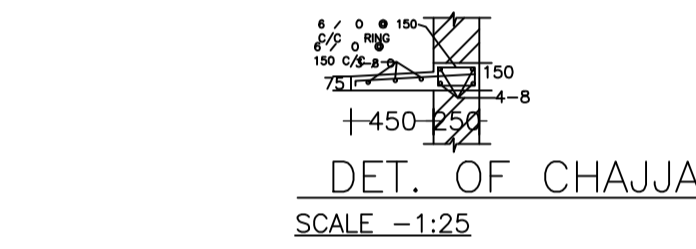

DET. OF CHAJJA  
SCALE -1:25

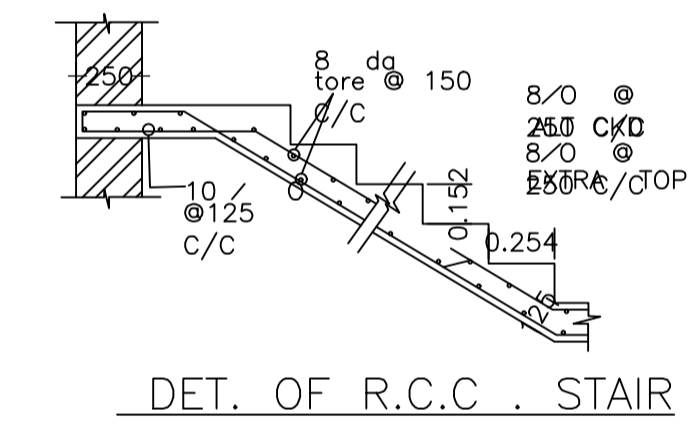

DET. OF R.C.C. STAIR

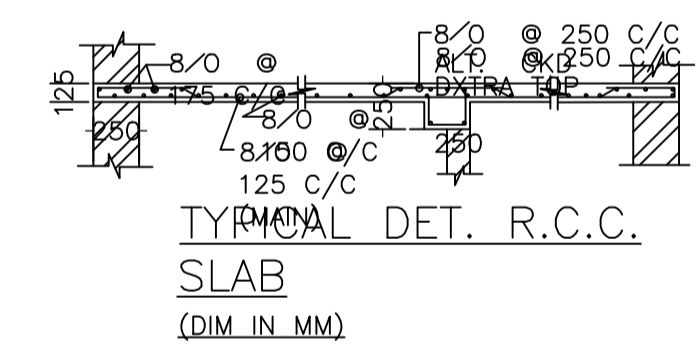

TYPICAL DET. R.C.C.  
SLAB  
(DIM. IN MM)

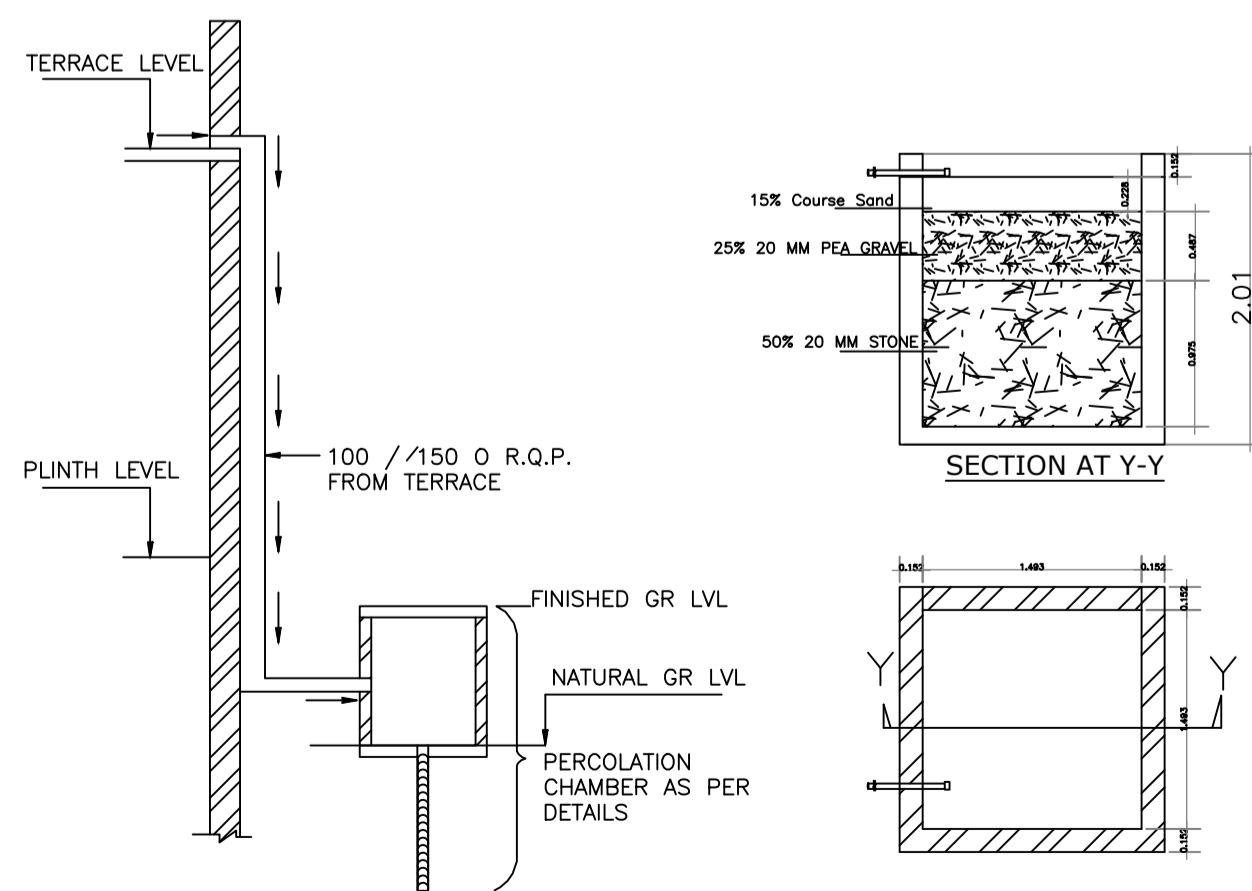
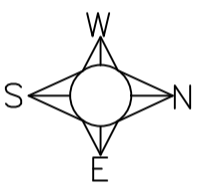
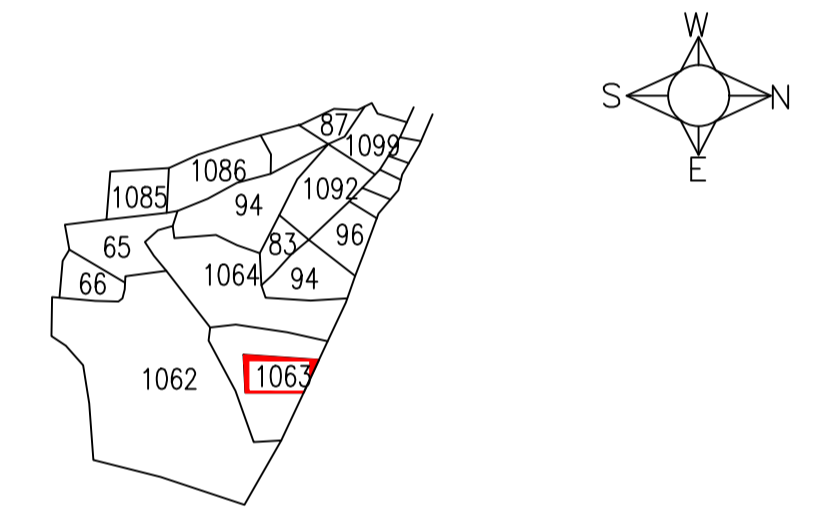

ROOF TOP RAIN WATER  
COLLECTION SYSTEM

PLAN OF RECHARGE  
WALLWATER HARVESTING

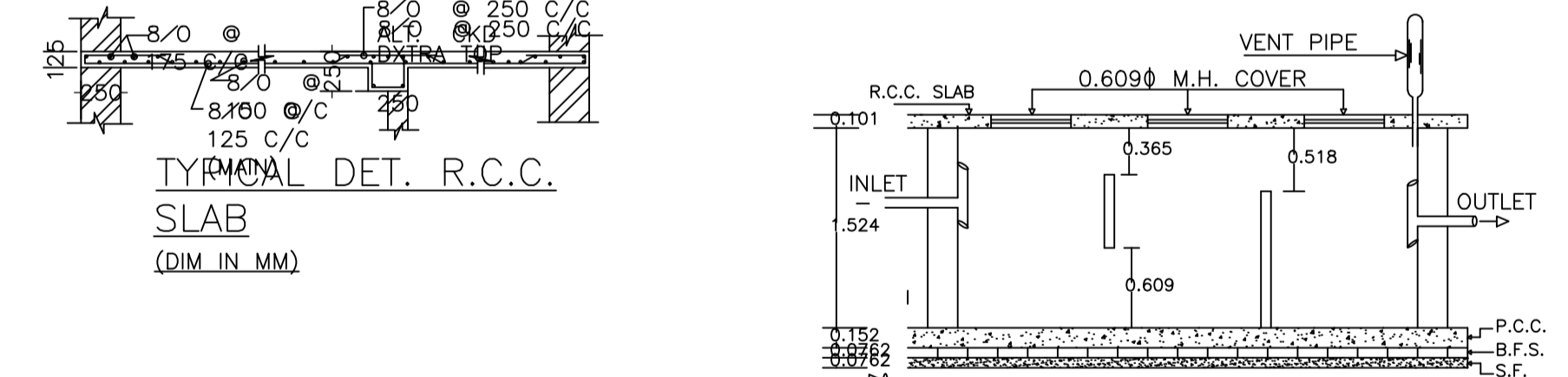

CROSS SECTION ON XX

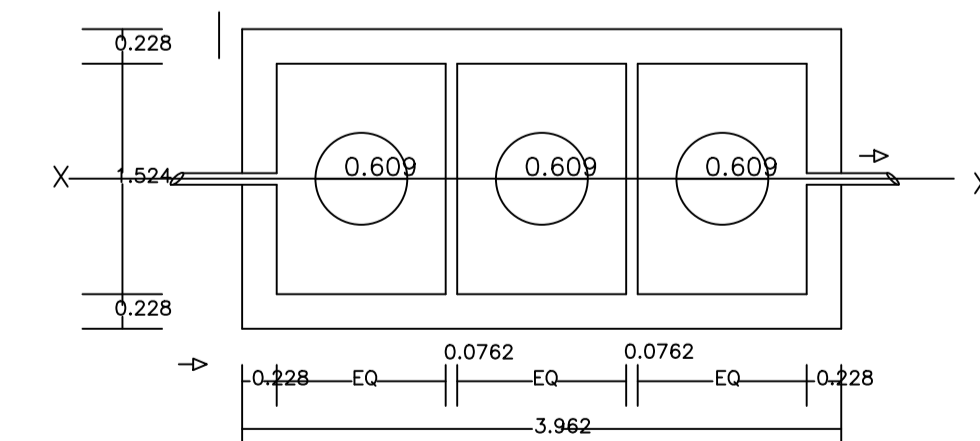

PLAN OF SEPTICTANK

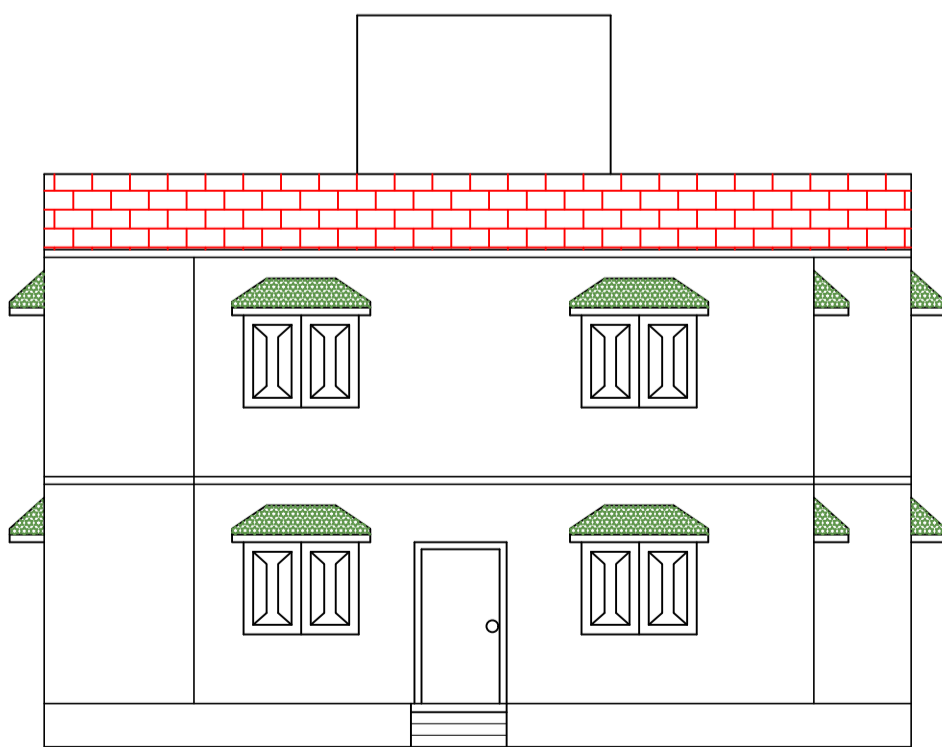

FRONT ELEVATION

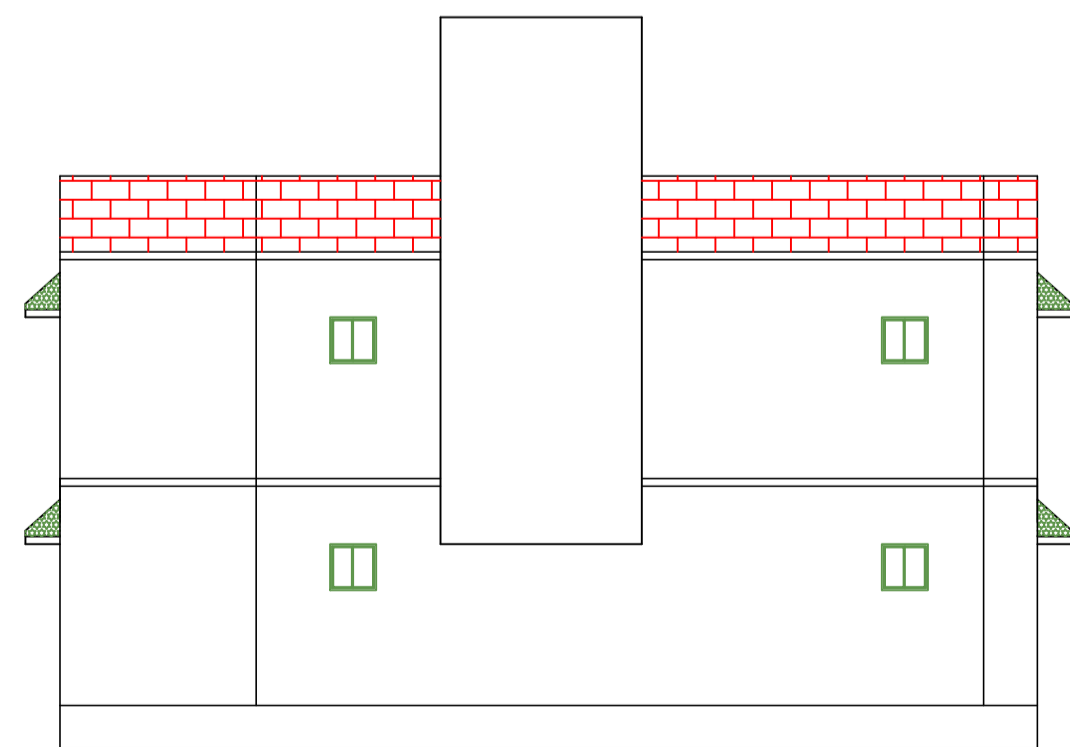

LEFT SIDE ELEVATION

LTP NAME AND SIGNATURE	STRUCTURAL ENG'S NAME AND SIGNATURE	BUILDER NAME AND SIGNATURE	DIGITAL SIGNATURE
SYED NAQUE ALAM DMC/ENG/0010/2017			