

Proposal Basic Information

Proposal File No.	DMC/BP/0219/W22/2022
Owner Name	Priyanka Sinha
Khata No	New 208 (old 87)
Plot No	New 783 (old 716)
Village Name	Bhelaland
Use	Residential
SubUse	Bungalow/ Dwelling / Non Apartment

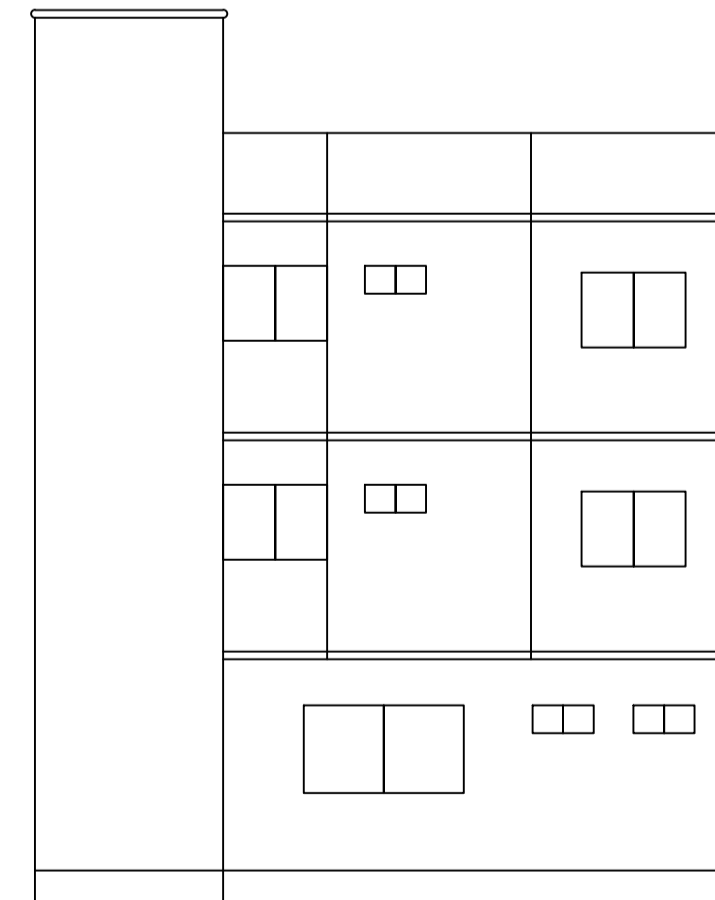
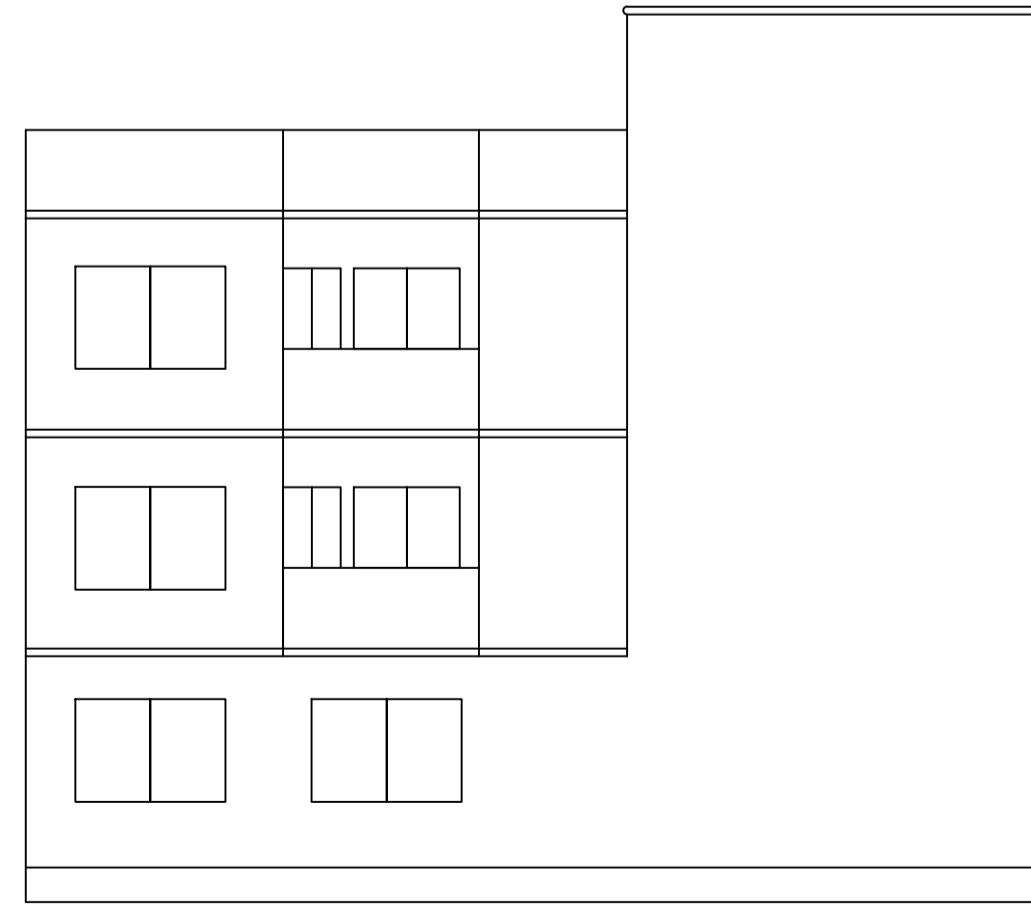
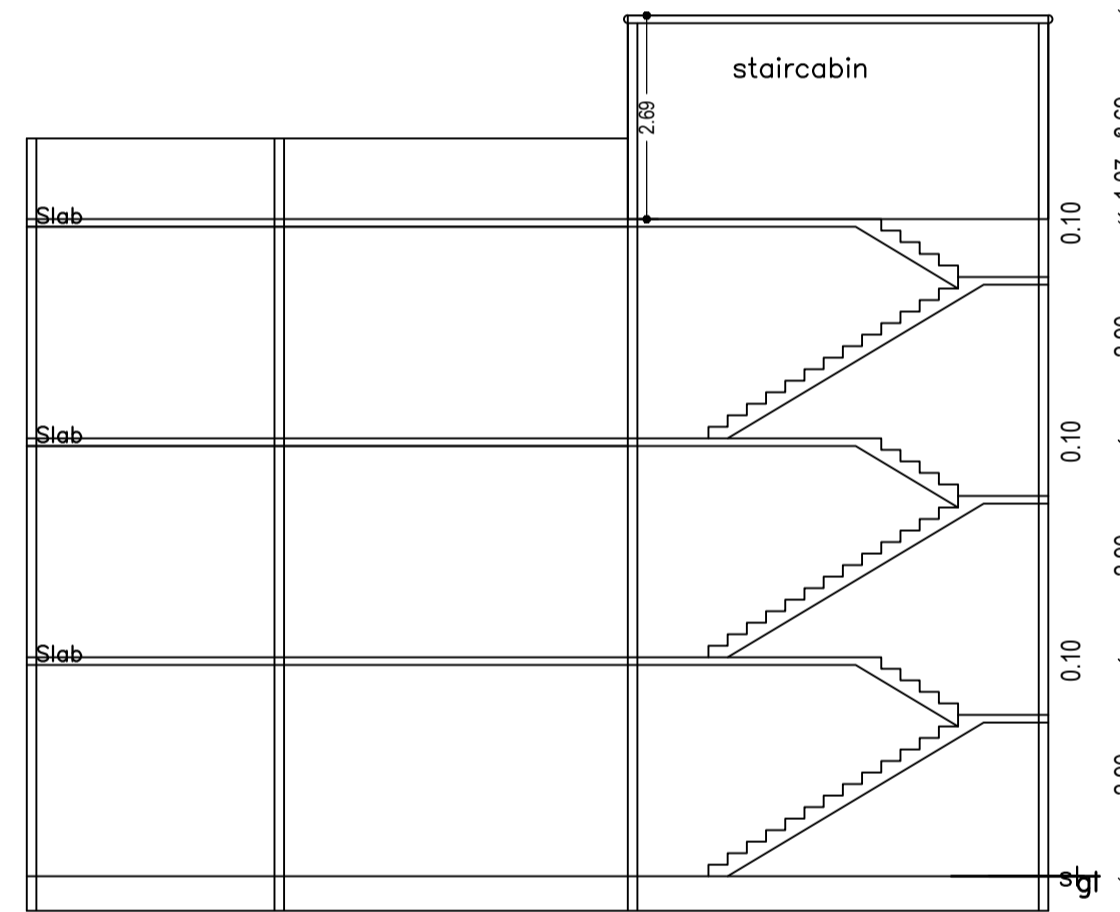
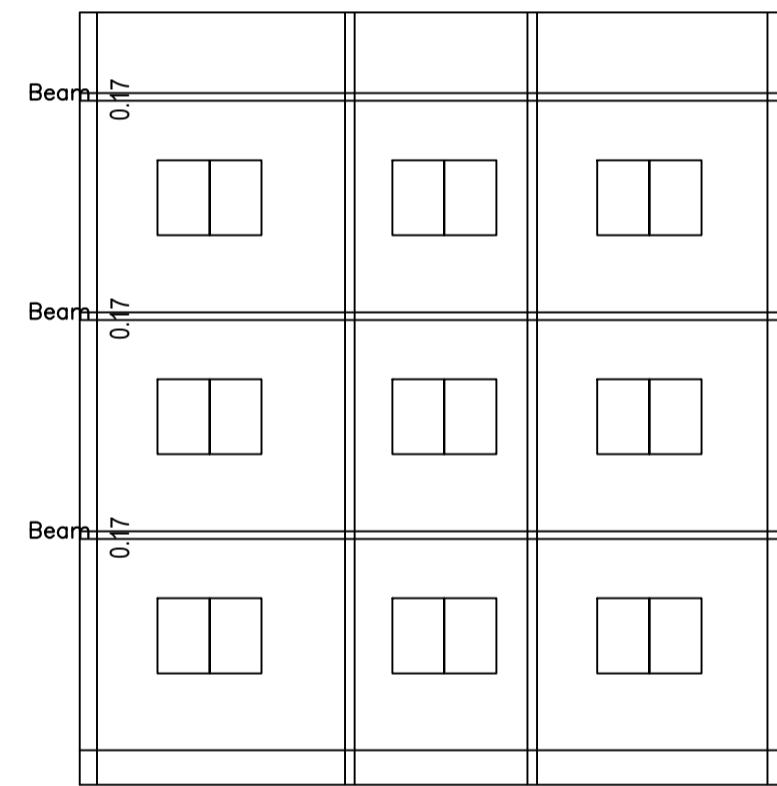
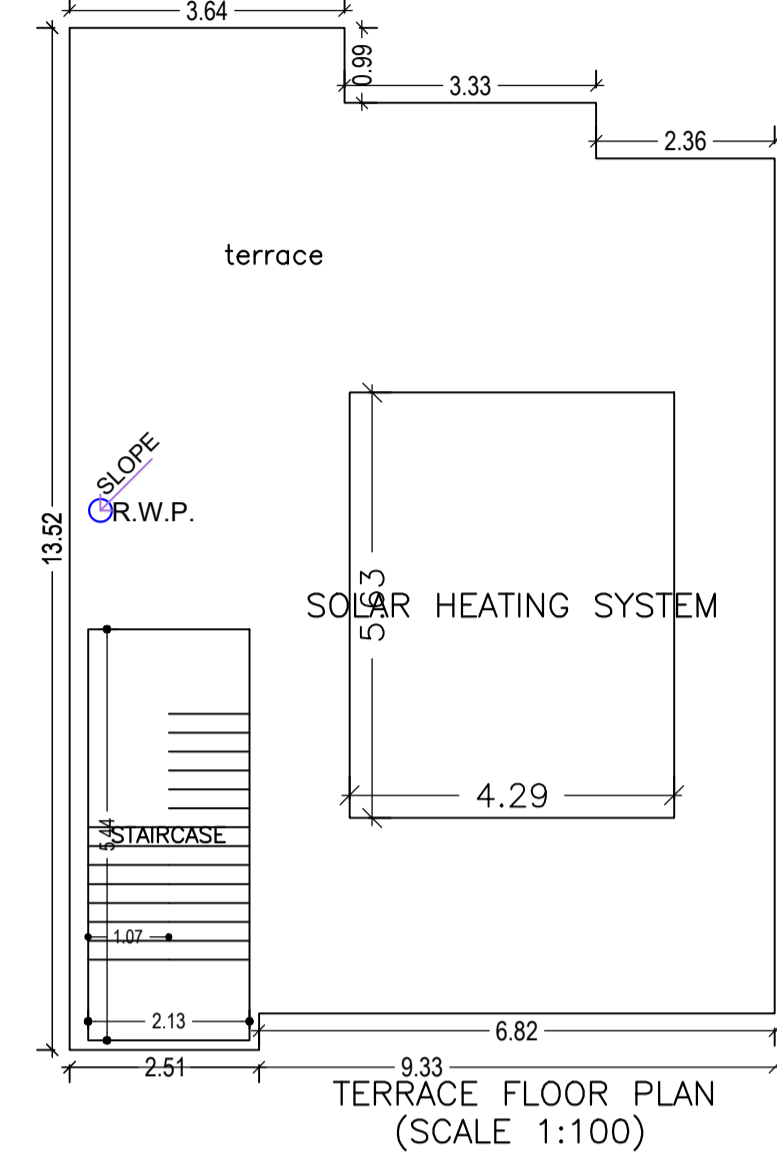
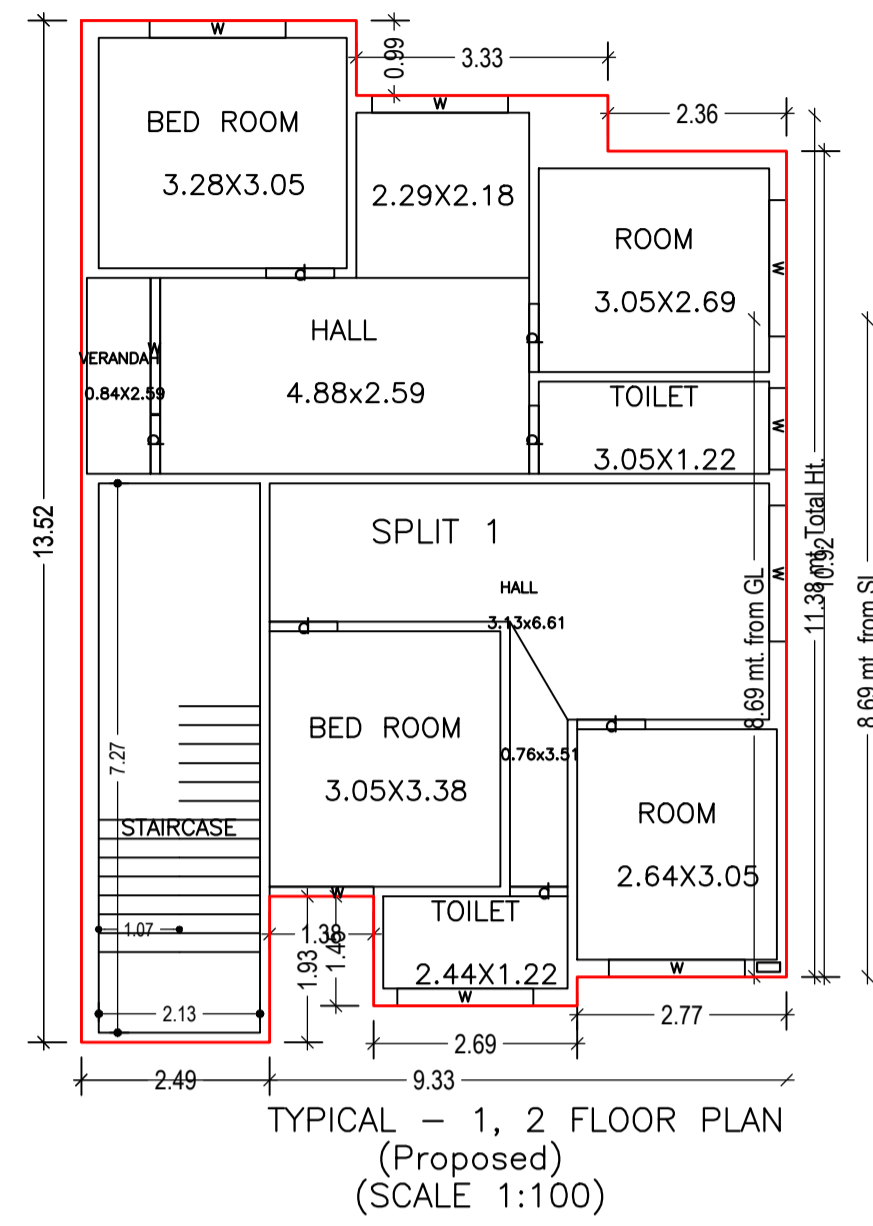
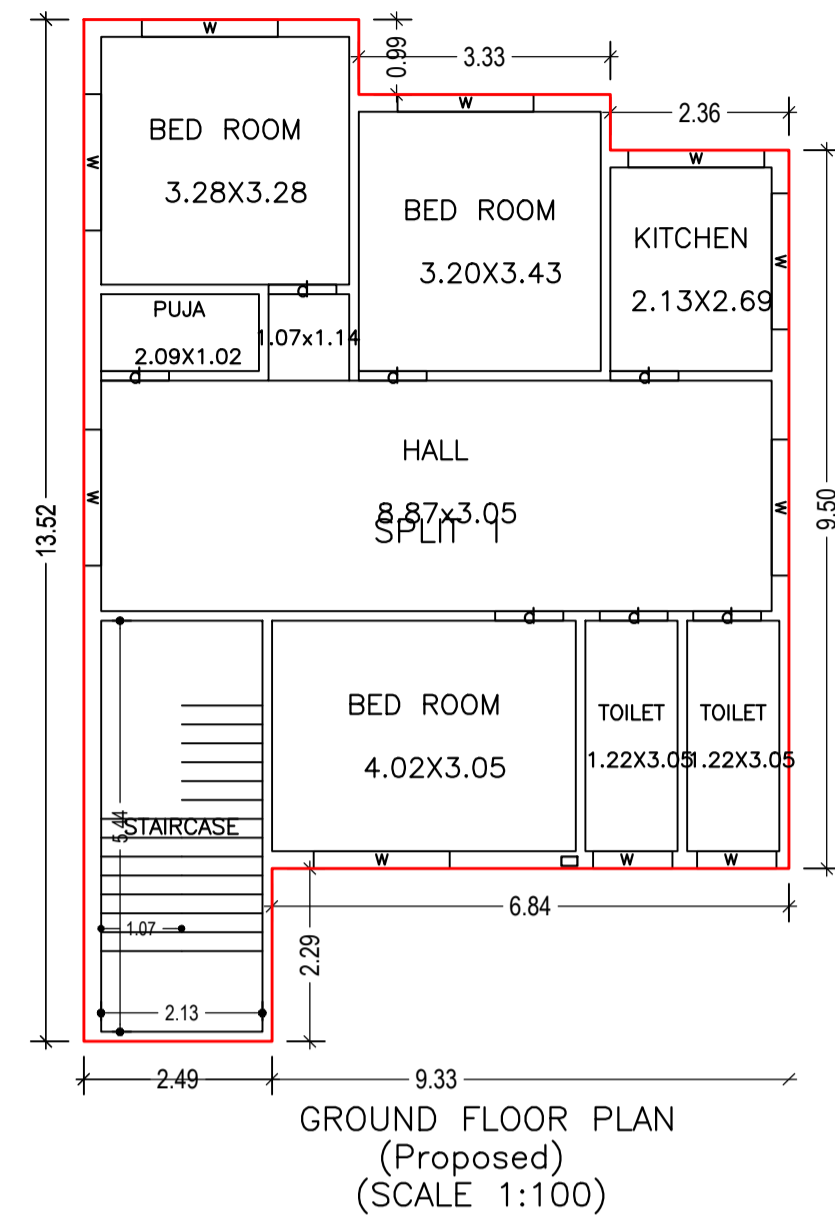
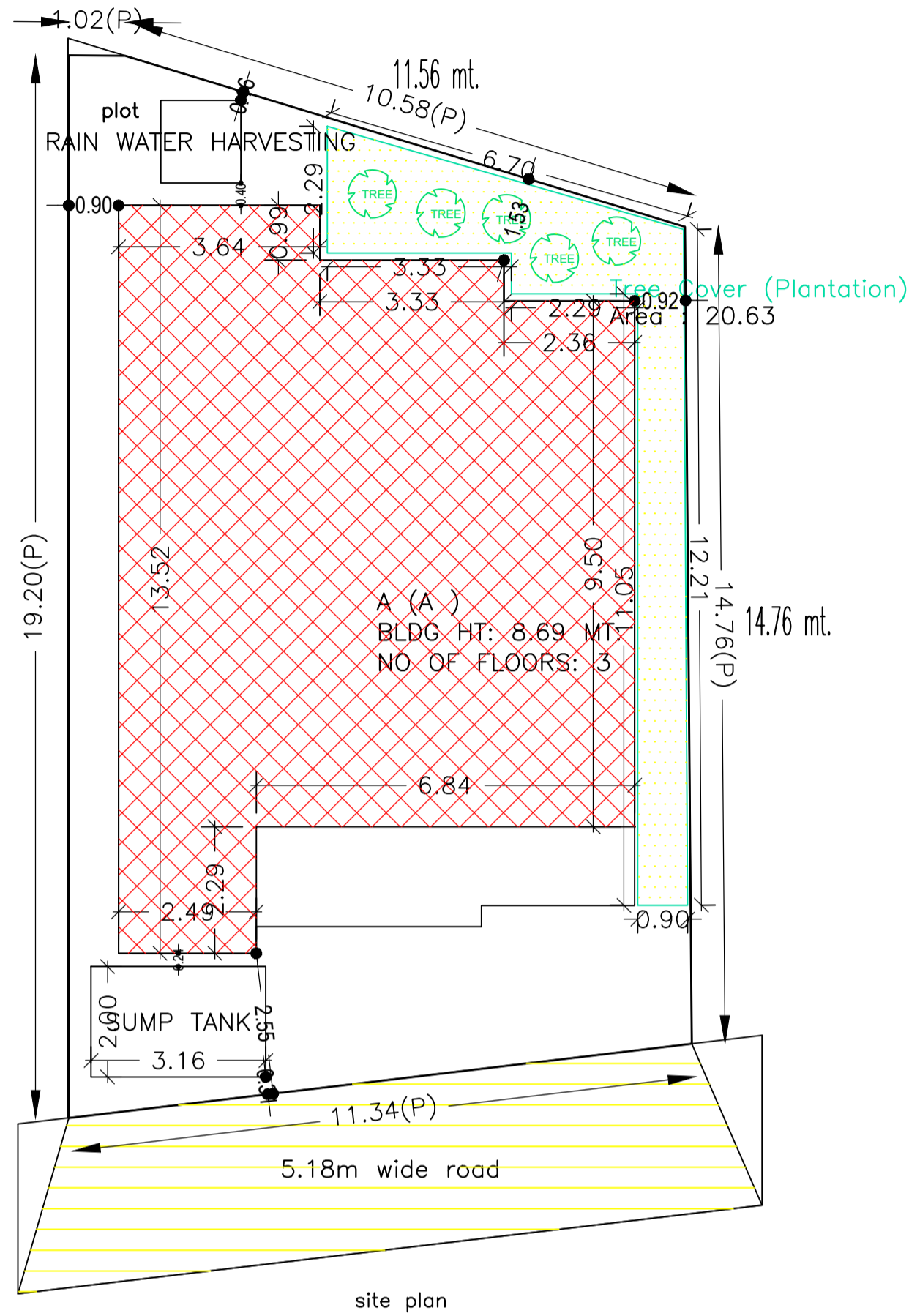

RIGHT SIDE ELEVATION

FRONT ELEVATION

AREA STATEMENT	VERSION NO. : 1.0.62	
DHANBAD MUNICIPAL CORPORATION	VERSION DATE: 16/10/2020	
PROJECT DETAIL:		
Region: JHARKHAND URBAN LOCAL BODIES	Plot Use: Residential	
District: DHANBAD	Plot SubUse: Bungalow/ Dwelling / Non Apartment	
Authority: DHANBAD MUNICIPAL CORPORATION	PlotNearby/ReligiousStructure: NA	
Inward_No: DMC/BP/0219/W22/2022	Plot/SubPlot No: New 783 (old 716)	
Application Type: General Proposal	North: Plot No. - smt supriya	
Project Type: Building Permission	South: Plot No. - same plot	
Nature of Development: New	East: Plot No. - 726	
Location of Development Area: Old Area	West: Road Width - 4.87	
AREA DETAILS:		
AREA OF PLOT (Minimum)	(A)	SQ.MT.
NET AREA OF PLOT(Gross Plot Area - Deduction from Gross Plot area)	(A-Deductions)	191.68
Deduction for Balance Plot Area(from Gross Plot Area)		
Common Plot		20.63
Total		20.63
BALANCE AREA OF PLOT(Net Plot Area - Recreational/Amenity space)	(A-Deductions)	171.05
PLOT AREA FOR COVERAGE(Net Plot Area)	(A-Deductions)	191.68
Plot Area for FAR (Net Plot Area + Road/Widening Area)	(A-Deductions)	191.68
COVERAGE CHECK		
Permissible Coverage area ( 70.00 % )		134.18
Proposed Coverage Area ( 53.77 % )		103.07
Total Prop. Coverage Area ( 53.77 % )		103.07
Balance coverage area ( 16.23 % )		31.11
FAR CHECK		
Perm. FAR Area ( 1.80 )		345.02
Total Perm. FAR area		345.02
Residential FAR		327.78
Proposed FAR Area		327.78
Total Proposed FAR Area		327.78
Consumed FAR (Factor)		1.71
Balance FAR Area		17.24
BUILT UP AREA CHECK		
Total Proposed BuiltUp Area		327.79
ARCHITECT (Regd)		AJAY KUMAR KESARI
ENGINEER (Regd)		
SUPERVISOR (Regd)		
OWNER (Regd)		Priyanka Sinha
DEVELOPMENT AUTHORITY		LOCAL BODY

COLOR INDEX	
PLOT BOUNDARY	Black
ABUTTING ROAD	Green
PROPOSED CONSTRUCTION	Red
COMMON PLOT	Yellow
ROAD WIDENING AREA	Blue
EXISTING (To be retained)	Orange
EXISTING (To be demolished)	Light Blue

Building :A ( A )

Floor Name	Total Built Up Area (Sq.mt.)	Proposed FAR Area (Sq.mt.) Resi.	Total FAR Area (Sq.mt.)	Additional FAR Area (Sq.mt.)	Trmnt (No.)
Ground Floor	103.07	103.07	103.07	103.07	01
First Floor	112.36	112.36	112.36	112.36	00
Second Floor	112.36	112.36	112.36	112.36	00
Terrace Floor	0.00	0.00	0.00	0.00	00
Total:	327.79	327.79	327.79	327.79	01
Total Number of Same Buildings :	1				
Total:	327.79	327.79	327.79	327.79	01

SCHEDULE OF DOOR:

BUILDING NAME	NAME	LENGTH	HEIGHT	NOS
A (A)	d	0.76	2.10	02
A (A)	d	0.78	2.10	02
A (A)	d	0.90	2.10	17

SCHEDULE OF WINDOW/VENTILATION:

BUILDING NAME	NAME	LENGTH	HEIGHT	NOS
A (A)	w	1.05	1.20	02
A (A)	w	1.08	1.20	02
A (A)	w	1.38	1.20	02
A (A)	w	1.80	1.20	22

UnitBUA Table for Building :A ( A )

FLOOR	Name	UnitBUA Type	UnitBUA Area	Carpet Area	No. of Rooms	No. of Tenement
GROUND FLOOR PLAN	SPLIT 1	FLAT	327.78	327.68	8	1
TYPICAL - 1, 2 FLOOR PLAN	SPLIT 1	FLAT	0.00	0.00	9	0
Total:	-	-	327.78	327.68	26	1

Buildingwise Floor FAR Details

Floor Name	Building Name A (A)		Total	
	Proposed Built Up Area (Sq.mt.)	Proposed FAR Area (Sq.mt.)	Total Proposed Built Up Area (Sq.mt.)	Total FAR Area (Sq.mt.)
Ground Floor	103.07	103.07	103.07	103.07
First Floor	112.36	112.36	112.36	112.36
Second Floor	112.36	112.36	112.36	112.36
Terrace Floor	0.00	0.00	0.00	0.00
Total :	327.79	327.79	327.79	327.79

Building USE/SUBUSE Details

Building Name	Building Use	Building SubUse	Building Structure
A (A)	Residential	Bungalow/ Dwelling / Non Apartment	Non-Hightrise

FAR & Tenement Details (Table 4c-1)

Building	No. of Same Bldg	Total Built Up Area (Sq.mt.)	Proposed FAR Area (Sq.mt.) Resi.	Total FAR Area (Sq.mt.)	Total Consumed Additional FAR Area (Sq.mt.)	Trmnt (No.)
A (A)	1	327.79	327.79	327.79	327.79	01
Grand Total :	1	327.79	327.79	327.79	327.79	01

LTP NAME AND SIGNATURE	STRUCTURAL ENG'S NAME AND SIGNATURE	BUILDER NAME AND SIGNATURE	DIGITAL SIGNATURE
AJAY KUMAR KESARI DMC/ENG/0007/2021			

Proposal Basic Information	
Proposal File No.	DMC/BP/0219/W22/2022
Owner Name	Priyanka Sinha
Khata No	New 208 (old 87)
Plot No	New 783 (old 716)
Village Name	Bhelaland
Use	Residential
SubUse	Bungalow/ Dwelling / Non Apartment

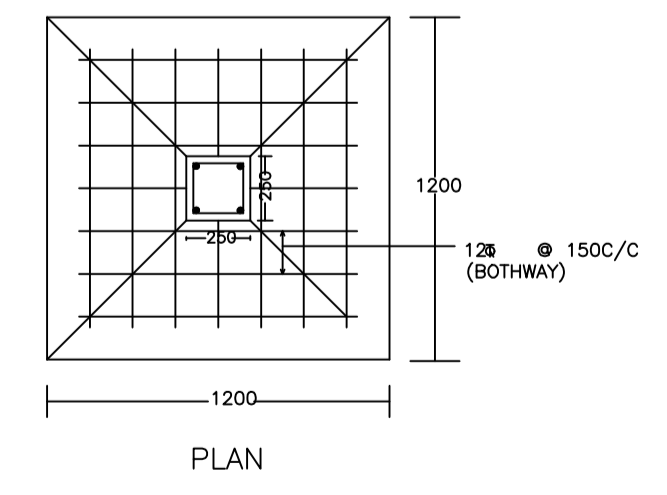
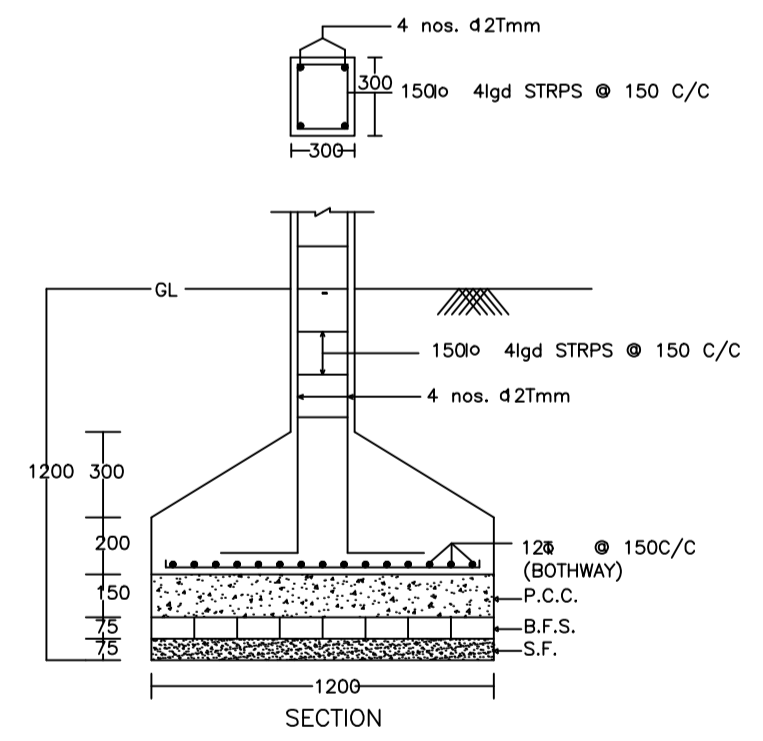
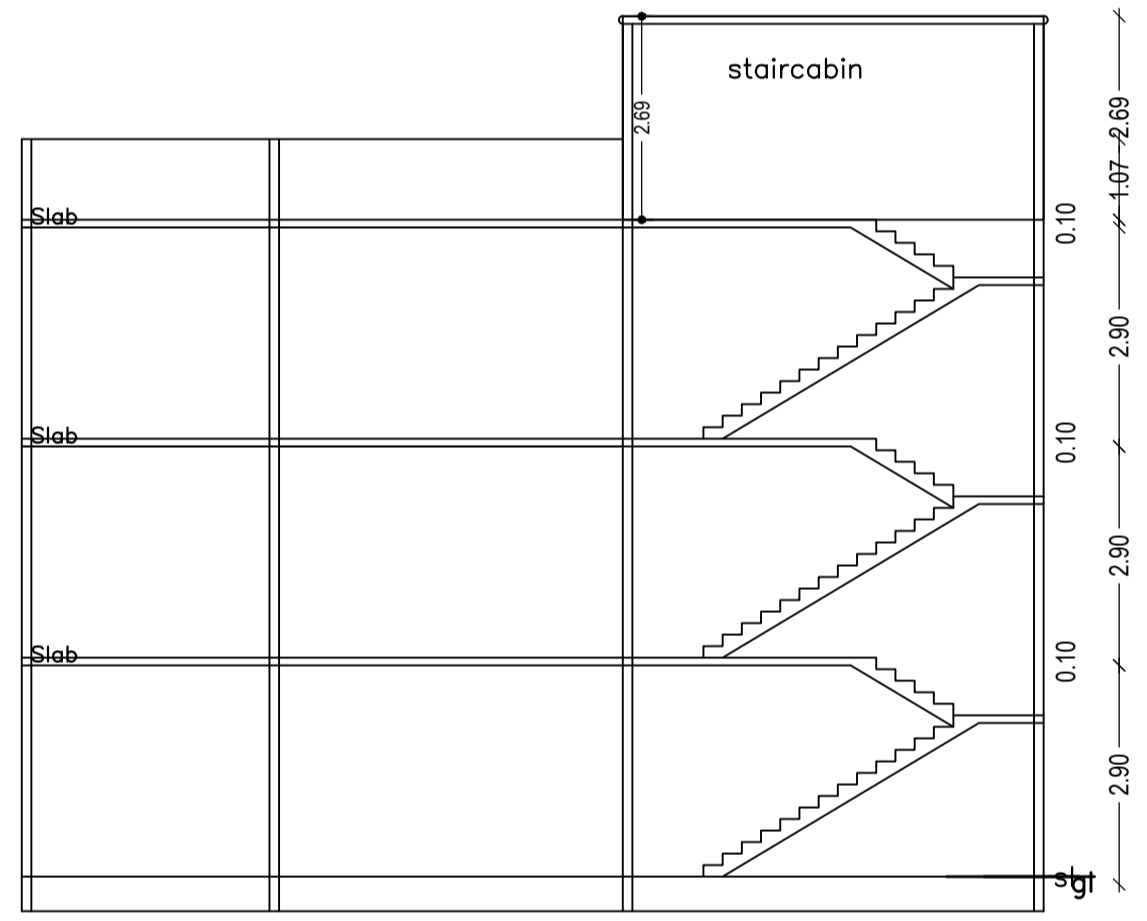
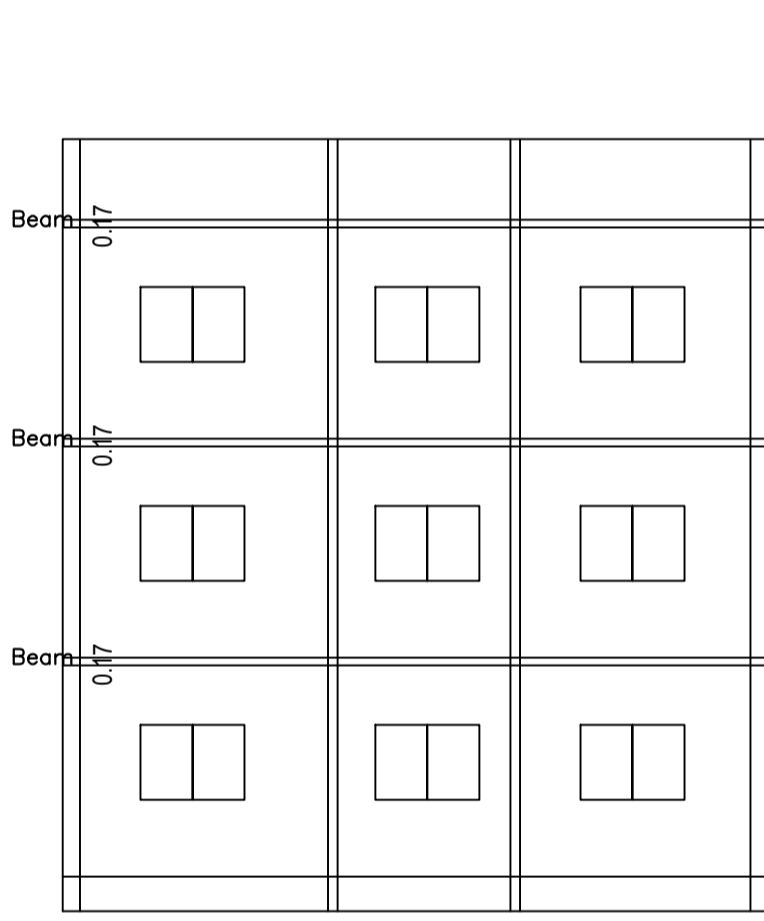
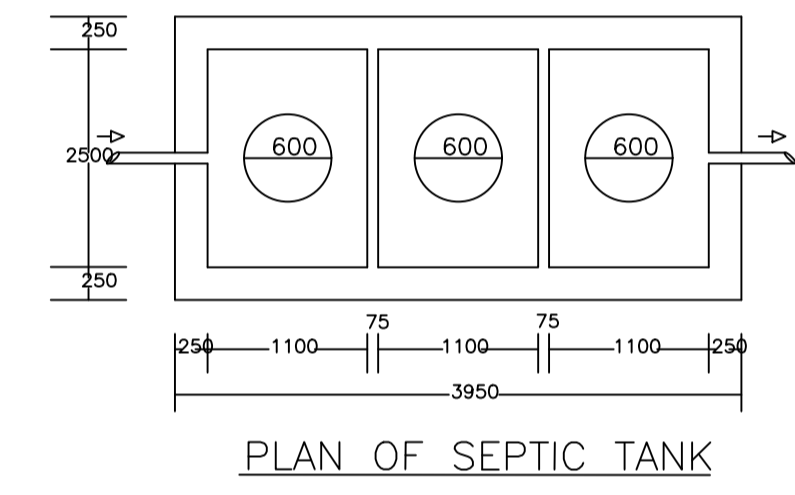
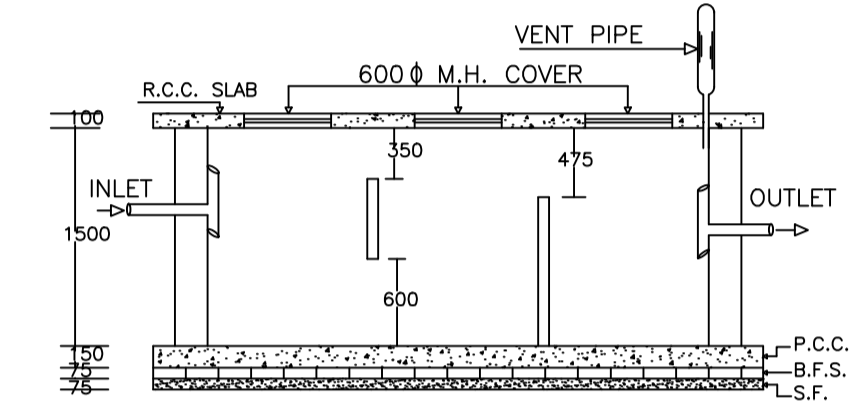
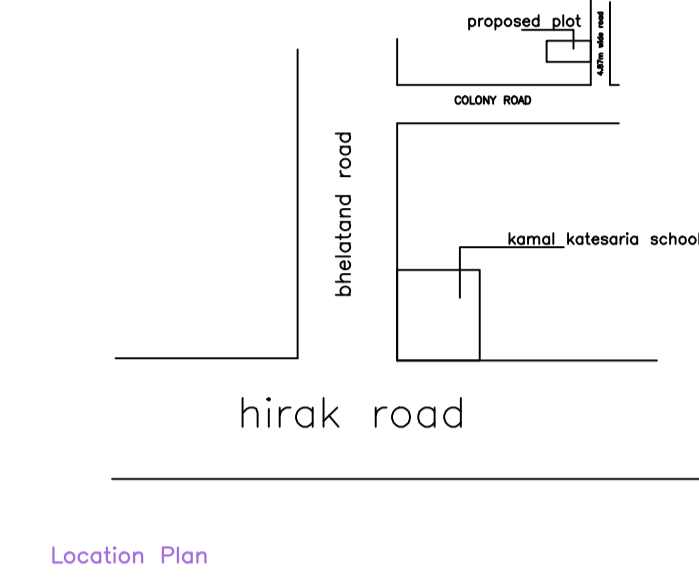
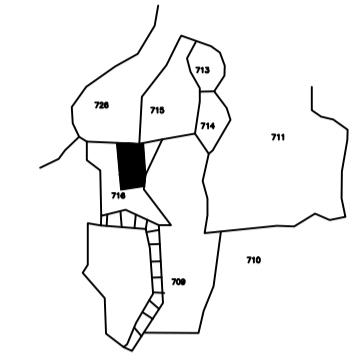
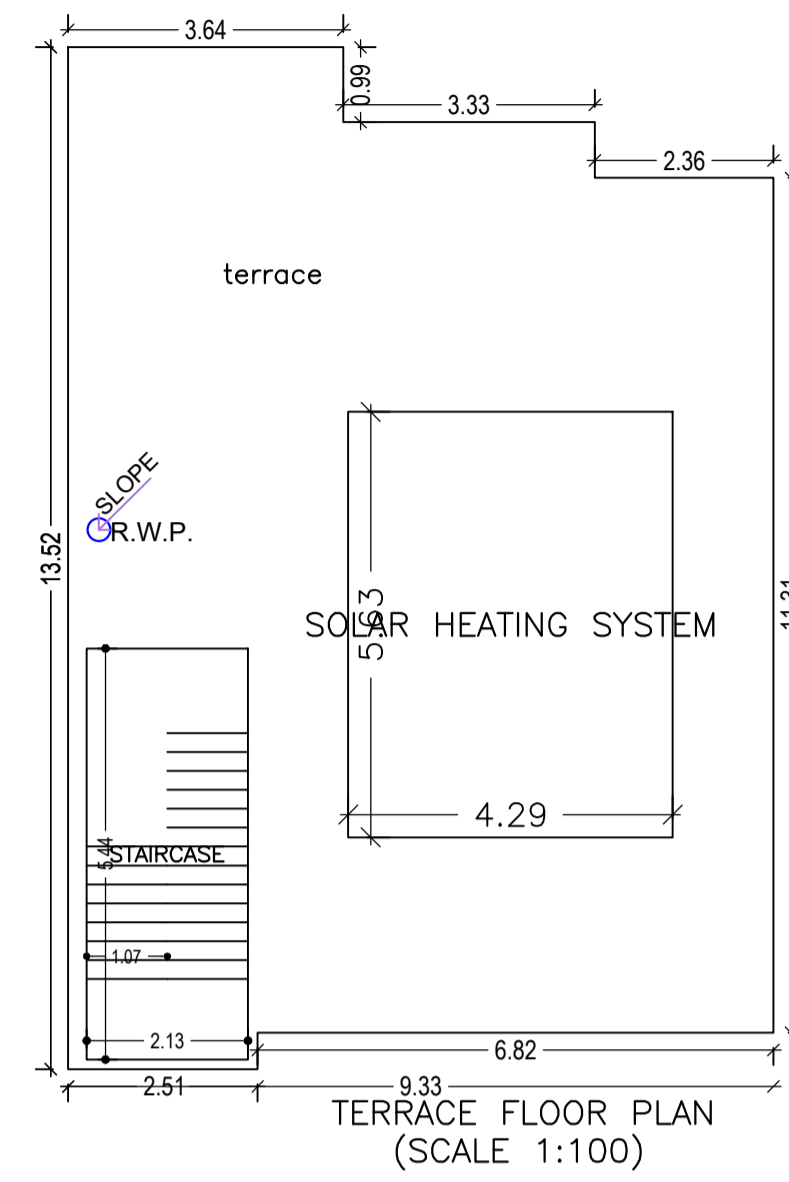
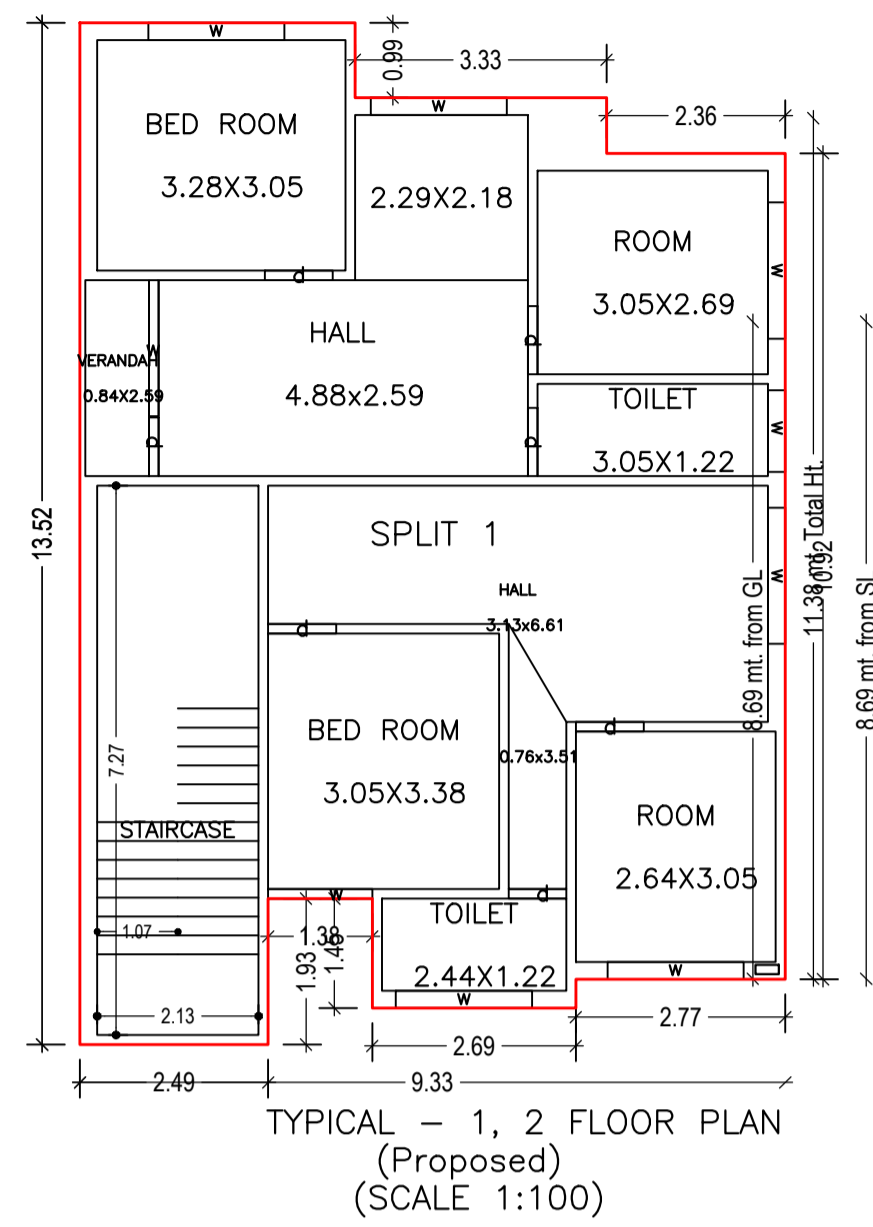
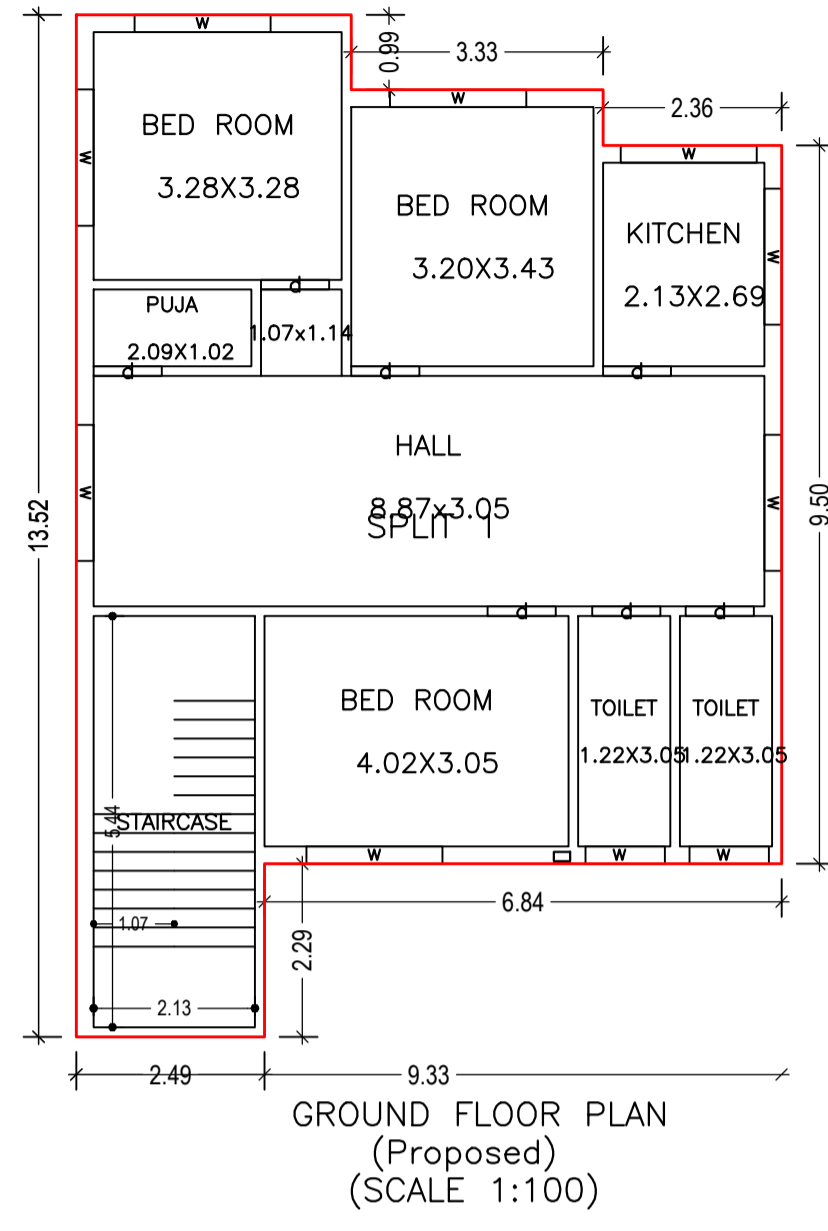

DETAIL OF COLUMNS

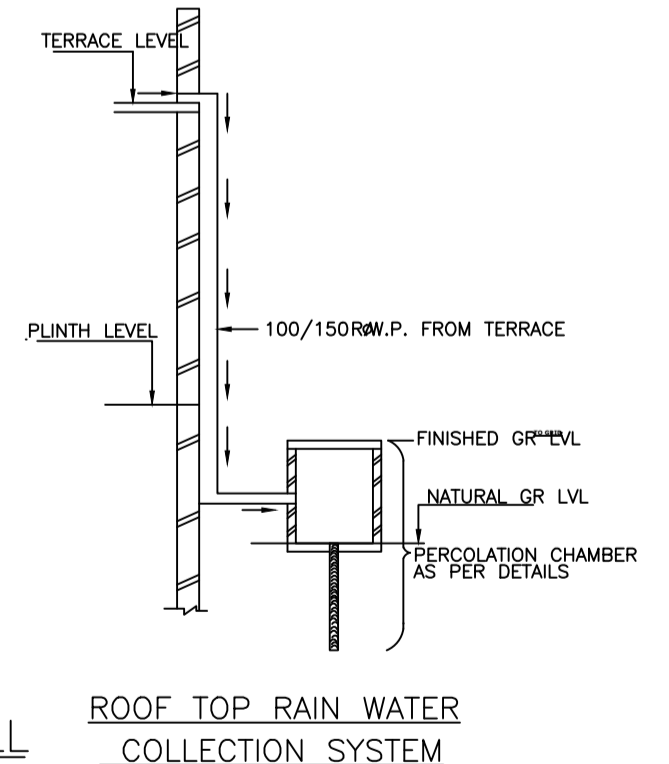
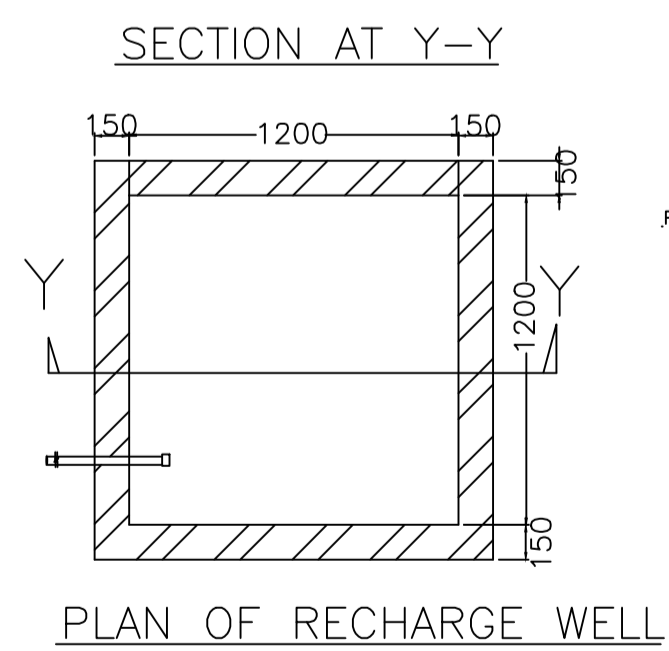
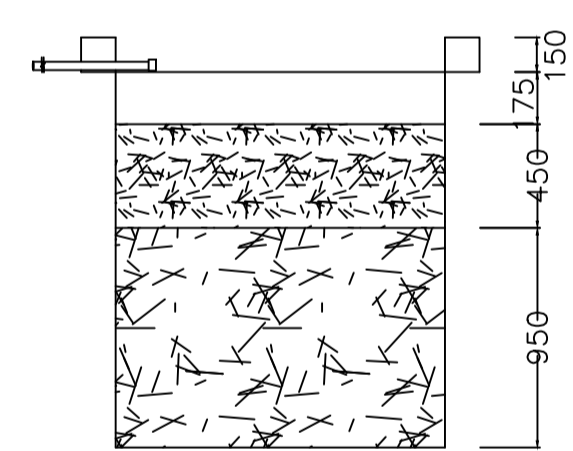

WATER HARVESTING

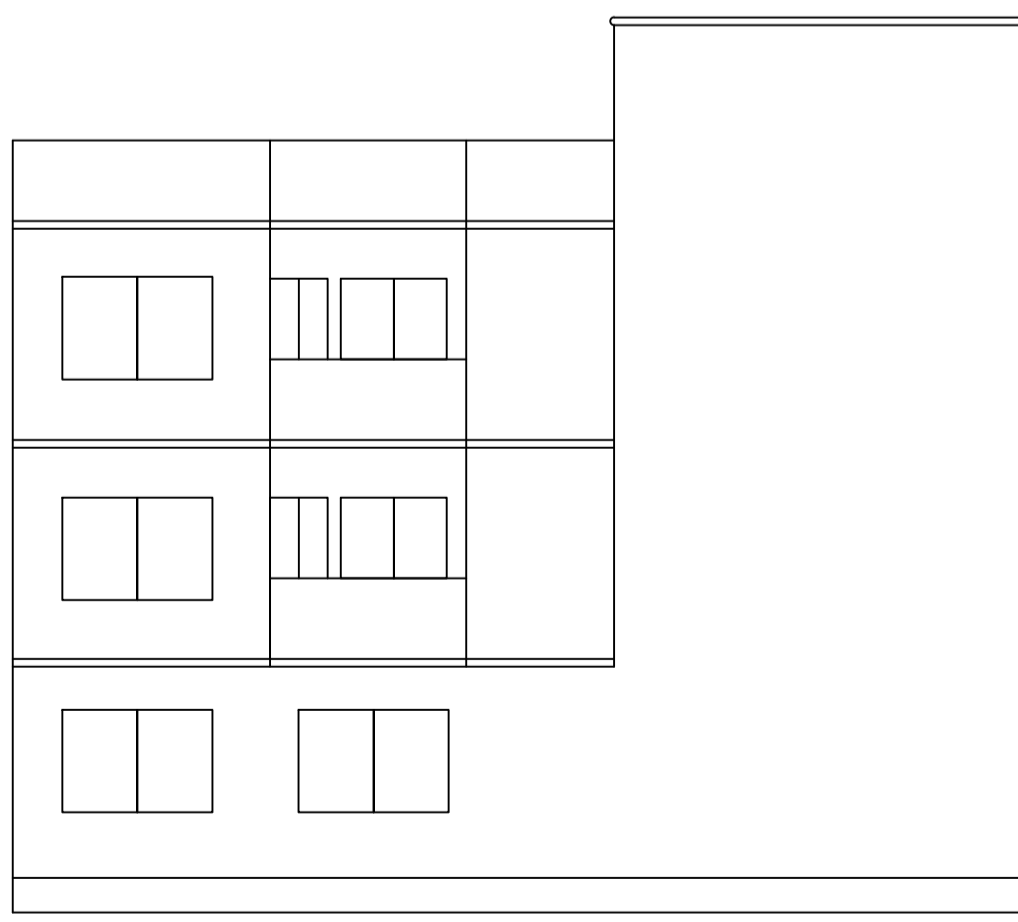

RIGHT SIDE ELEVATION

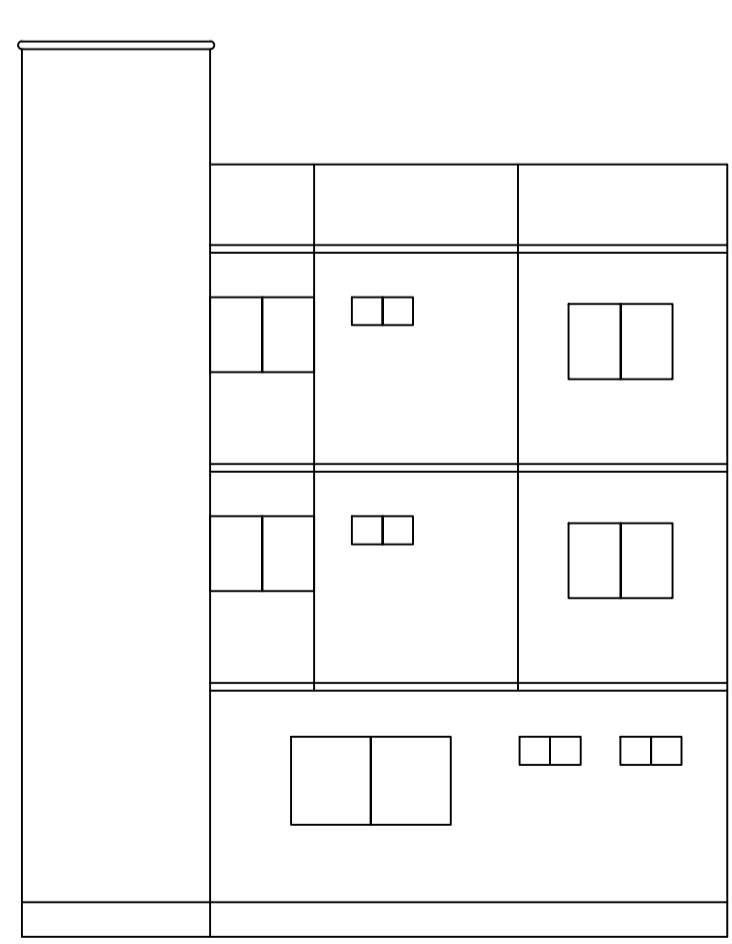

FRONT ELEVATION

LTP NAME AND SIGNATURE	STRUCTURAL ENG'S NAME AND SIGNATURE	BUILDER NAME AND SIGNATURE	DIGITAL SIGNATURE
AJAY KUMAR KESARI DMC/ENG/0007/2021			