

SITE PLAN

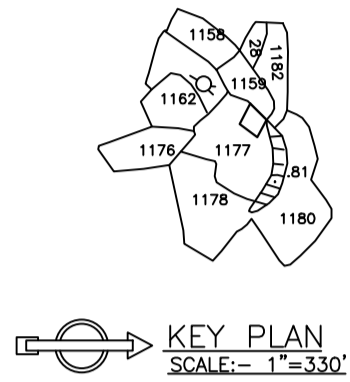
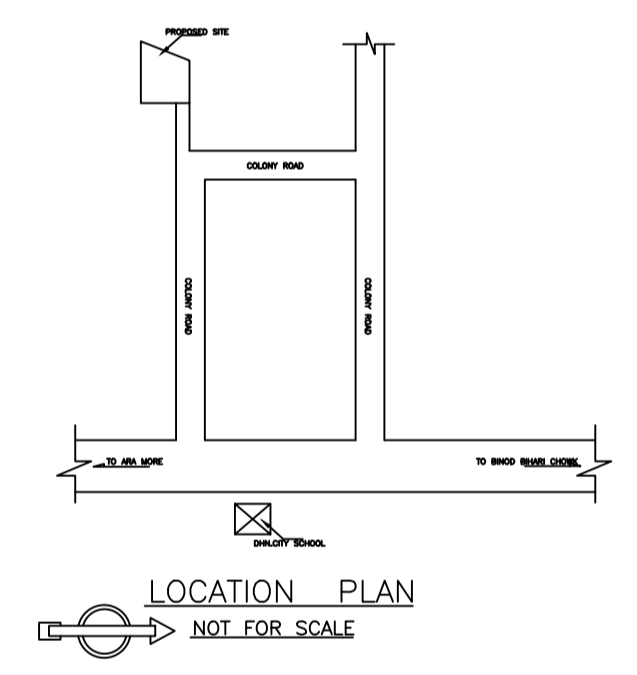
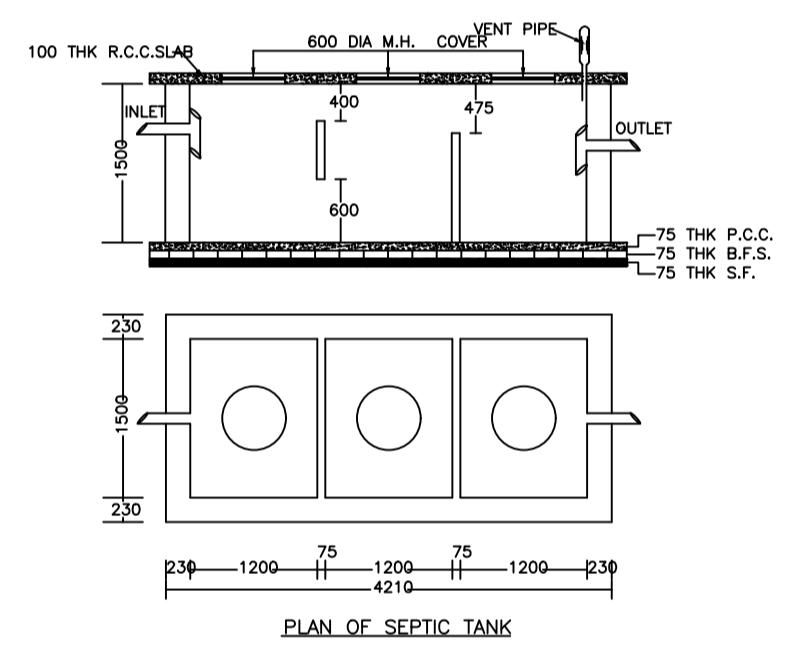
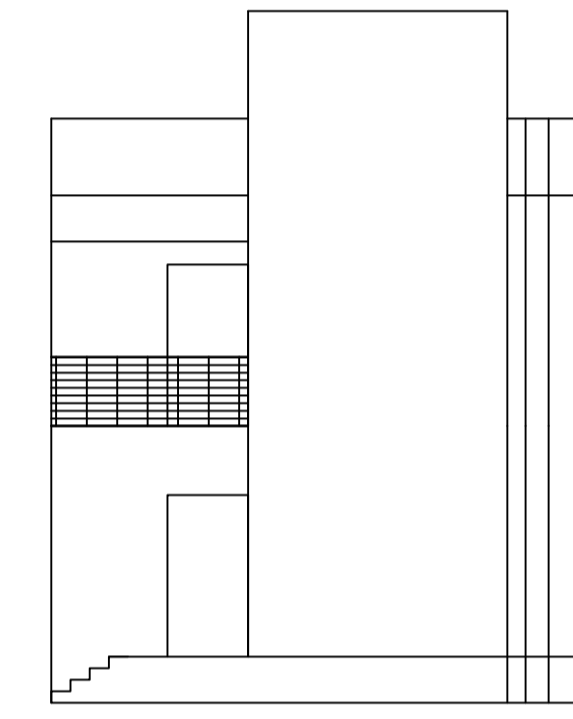
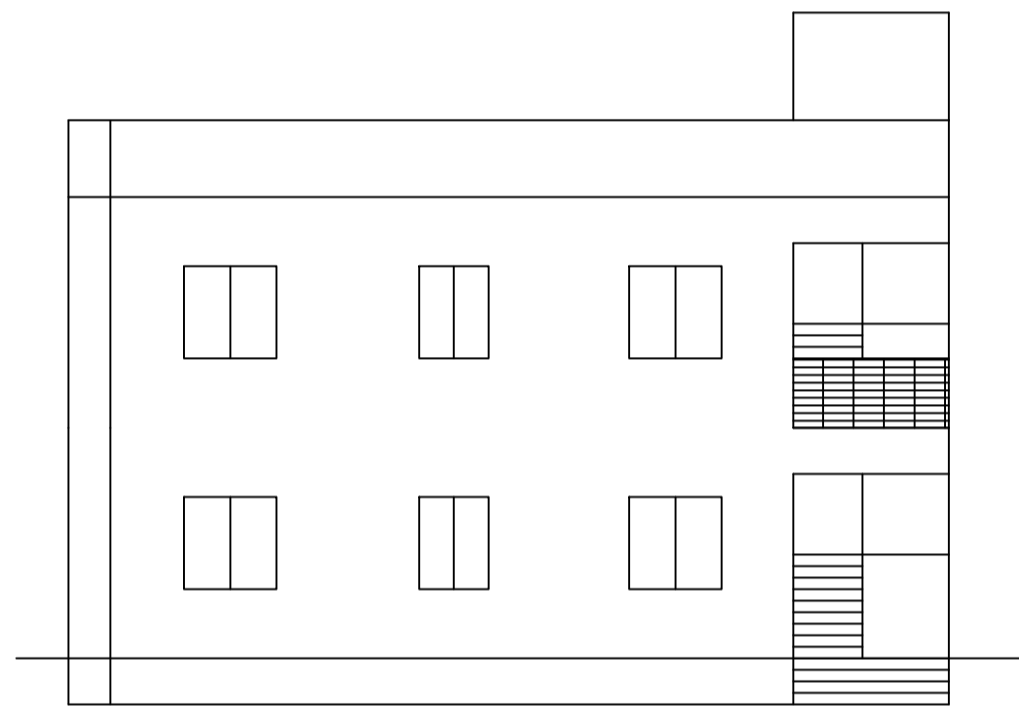
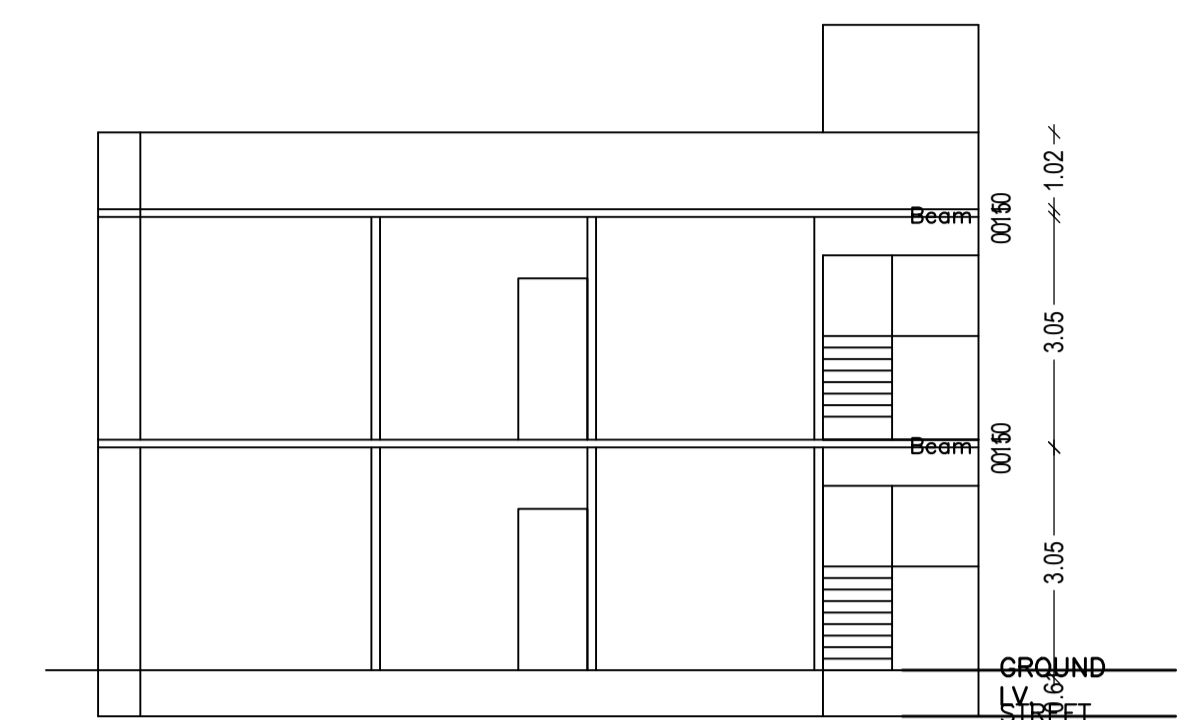
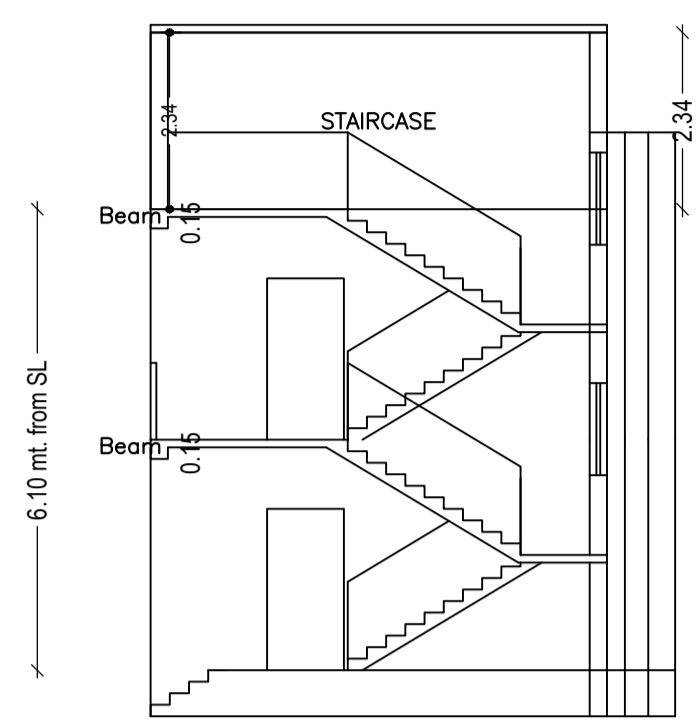

Proposal Basic Information

Proposal File No.	DMC/BP/0232/W17/2022
Owner Name	Sarfarazul Haque
Khata No	48 (OLD), 601 (NEW)
Plot No	1235 (OLD), 1177 (NEW)
Village Name	Panderpala
Use	Residential
SubUse	Bungalow/ Dwelling / Non Apartment

AREA STATEMENT	VERSION NO. : 1.0.62
DHANBAD MUNICIPAL CORPORATION	VERSION DATE: 16/10/2020
PROJECT DETAIL:	
Region: JHARKHAND URBAN LOCAL BODIES	Plot Use: Residential
District: DHANBAD	Plot SubUse: Bungalow/ Dwelling / Non Apartment
Authority: DHANBAD MUNICIPAL CORPORATION	Plot/Nearby/Religious/Structure: NA
Inward No: DMC/BP/0232/W17/2022	Plot/SubPlot No: 1235 (OLD), 1177 (NEW)
Application Type: General Proposal	North: Plot No. - MD SAJID HUSSAIN
Project Type: Building Permission	South: Plot No. - MD SAGAR ANSARI
Nature of Development: New	East: Road Width - MALKA BANO & RASTA
Location of Development Area: Old Area	West: Plot No. - SALIM MODI PLOT NO. 1248 & 1249
AREA DETAILS:	
AREA OF PLOT (Minimum)	(A) 148.04
Deduction for NetPlot Area	
Surrender Free of Cost	6.45
Total	6.45
NET AREA OF PLOT(Gross Plot Area - Deduction from Gross Plot area)	(A-Deductions) 141.59
Deduction for Balance Plot Area(from Gross Plot Area)	
Surrender Free of Cost	6.45
Common Plot	19.79
Total	26.25
BALANCE AREA OF PLOT(Net Plot Area - Recreational/Amenity spaces)	(A-Deductions) 121.79
PLOT AREA FOR COVERAGE(Net Plot Area)	(A-Deductions) 141.59
Plot Area for FAR (Net Plot Area + RoadWidening Area)	(A-Deductions) 148.04
COVERAGE CHECK	
Permissible Coverage area (70.00 %)	99.11
Proposed Coverage Area (52.29 %)	74.04
Total Prop. Coverage Area (52.29 %)	74.04
Balance coverage area (17.71 %)	25.07
FAR CHECK	
Perm. FAR Area (1.20)	177.65
Total Perm. FAR area	177.65
Residential FAR	148.08
Proposed FAR Area	148.08
Total Proposed FAR Area	148.08
Consumed FAR (Factor)	1.00
Balance FAR Area	29.57
BUILT UP AREA CHECK	
Total Proposed BuiltUp Area	148.08
ARCHITECT (Regd)	PIYUSH KANTI SINGH
ENGINEER (Regd)	
SUPERVISOR (Regd)	
OWNER (Regd)	Sarfarazul Haque
DEVELOPMENT AUTHORITY LOCAL BODY	

COLOR INDEX

PLOT BOUNDARY	Black
ABUTTING ROAD	Green
PROPOSED CONSTRUCTION	Red
COMMON PLOT	Yellow
ROAD WIDENING AREA	Orange
EXISTING (To be retained)	Blue
EXISTING (To be demolished)	Light Blue

SCHEDULE OF DOOR:

BUILDING NAME	NAME	LENGTH	HEIGHT	NOS
A (SHAMSUL HAQUE)	D3	0.76	2.10	04
A (SHAMSUL HAQUE)	D2	0.91	2.10	02
A (SHAMSUL HAQUE)	D	1.02	2.10	08

SCHEDULE OF WINDOW/VENTILATION:

BUILDING NAME	NAME	LENGTH	HEIGHT	NOS
A (SHAMSUL HAQUE)	V	0.61	0.61	04
A (SHAMSUL HAQUE)	W1	0.92	1.20	02
A (SHAMSUL HAQUE)	W	1.22	1.20	14

UnitBUA Table for Building :A (SHAMSUL HAQUE)

FLOOR	Name	UnitBUA Type	UnitBUA Area	Carpet Area	No. of Rooms	No. of Tenement
GROUND FLOOR PLAN	SPLIT 1	FLAT	148.08	148.02	8	1
FIRST FLOOR PLAN	SPLIT 1	FLAT	0.00	0.00	8	0
Total:	-	-	148.08	148.02	16	1

FAR & Tenement Details (Table 4c-1)

Building	No. of Same Bldg	Total Built Up Area (Sq.mt.)	Proposed FAR Area (Sq.mt.) Res.	Total FAR Area (Sq.mt.)	Total Consumed Additional FAR Area (Sq.mt.)	Trmt (No.)
A (SHAMSUL HAQUE)	1	148.08	148.08	148.08	148.08	01
Grand Total:	1	148.08	148.08	148.08	148.08	01

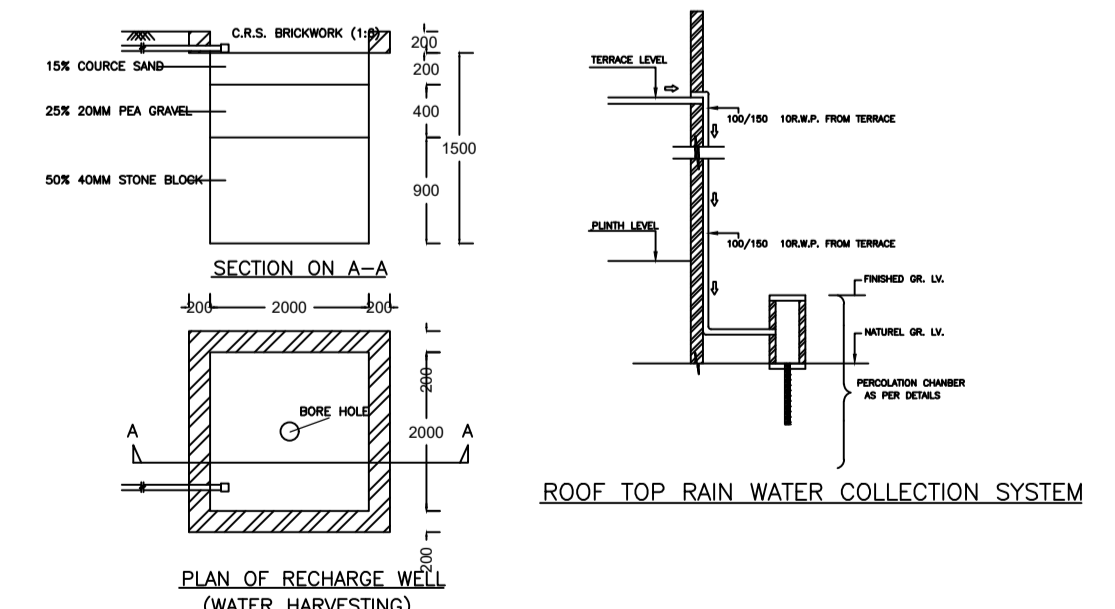

ROOF TOP RAIN WATER COLLECTION SYSTEM

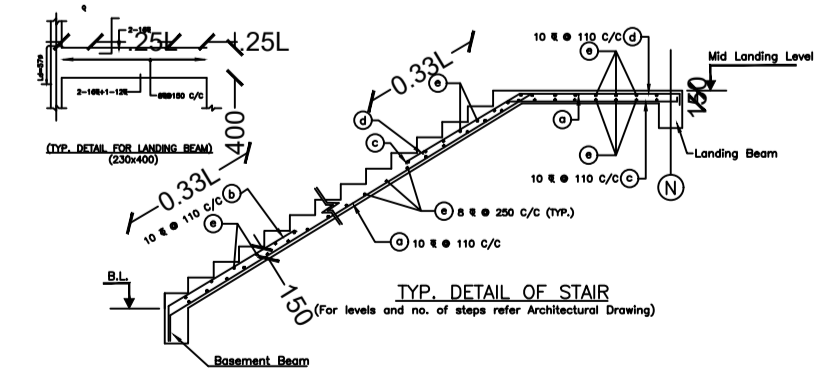
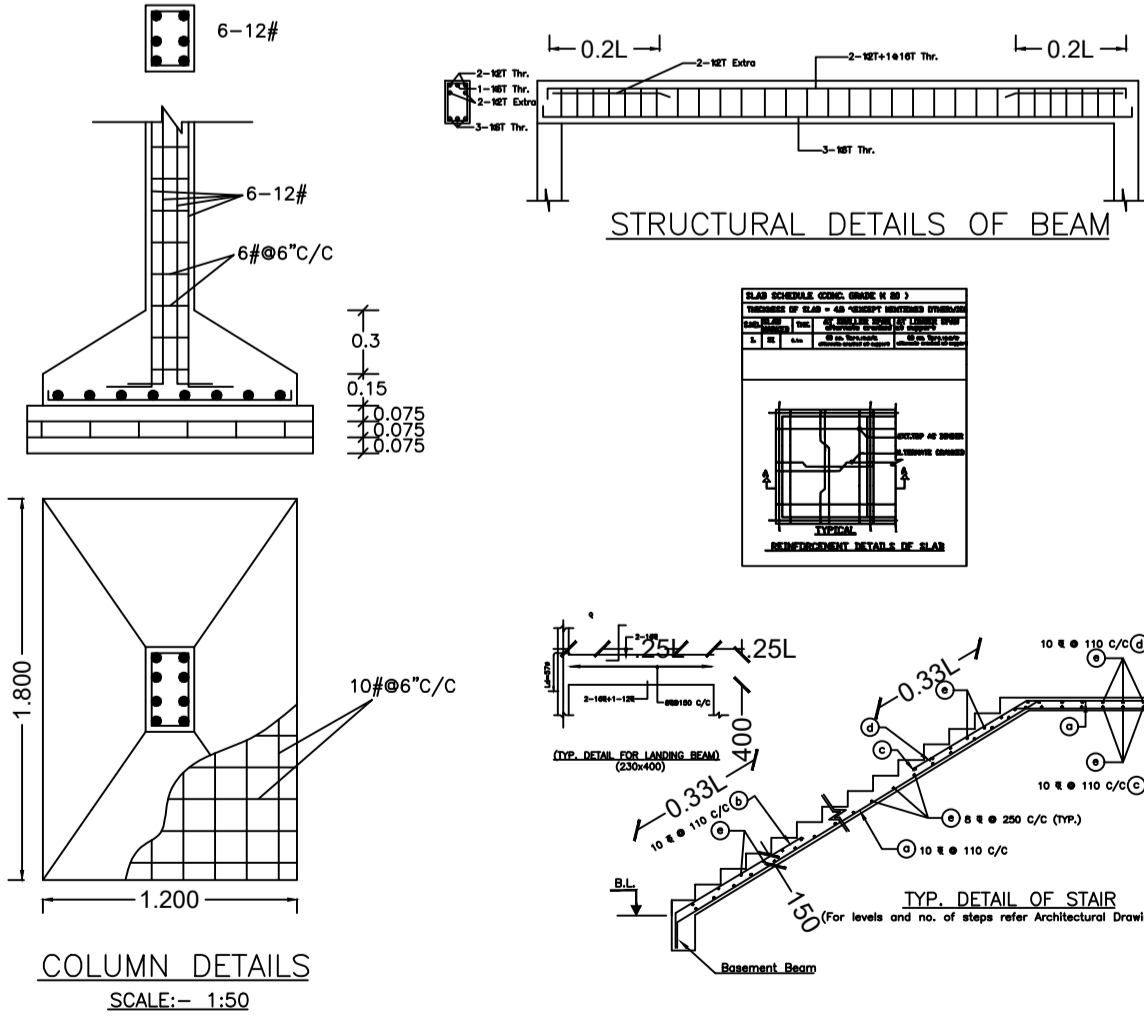

Buildingwise Floor FAR Details

Floor Name	Building Name A (SHAMSUL HAQUE)		Total	
	Proposed Built Up Area (Sq.mt.)	Proposed FAR Area (Sq.mt.)	Total Proposed Built Up Area (Sq.mt.)	Total FAR Area (Sq.mt.)
Ground Floor	74.04	74.04	74.04	74.04
First Floor	74.04	74.04	74.04	74.04
Terrace Floor	0.00	0.00	0.00	0.00
Total:	148.08	148.08	148.08	148.08

Building USE/SUBUSE Details

Building Name	Building Use	Building SubUse	Building Structure
A (SHAMSUL HAQUE)	Residential	Bungalow/ Dwelling / Non Apartment	Non-Highrise

Building :A (SHAMSUL HAQUE)

Floor Name	Total Built Up Area (Sq.mt.)	Proposed FAR Area (Sq.mt.) Res.	Total FAR Area (Sq.mt.)	Total Consumed Additional FAR Area (Sq.mt.)	Trmt (No.)
Ground Floor	74.04	74.04	74.04	74.04	01
First Floor	74.04	74.04	74.04	74.04	00
Terrace Floor	0.00	0.00	0.00	0.00	00
Total:	148.08	148.08	148.08	148.08	01
Total Number of Same Buildings :	1				
Total:	148.08	148.08	148.08	148.08	01

LTP NAME AND SIGNATURE	STRUCTURAL ENG'S NAME AND SIGNATURE	BUILDER NAME AND SIGNATURE	DIGITAL SIGNATURE
PIYUSH KANTI SINGH DMC/ENG/0020/2016			

Proposal Basic Information

Proposal File No.	DMC/BP/0232/W17/2022
Owner Name	Sarfarazul Haque
Khata No	48 (OLD) , 601 (NEW)
Plot No	1235 (OLD) , 1177 (NEW)
Village Name	Panderpala
Use	Residential
SubUse	Bungalow/ Dwelling / Non Apartment

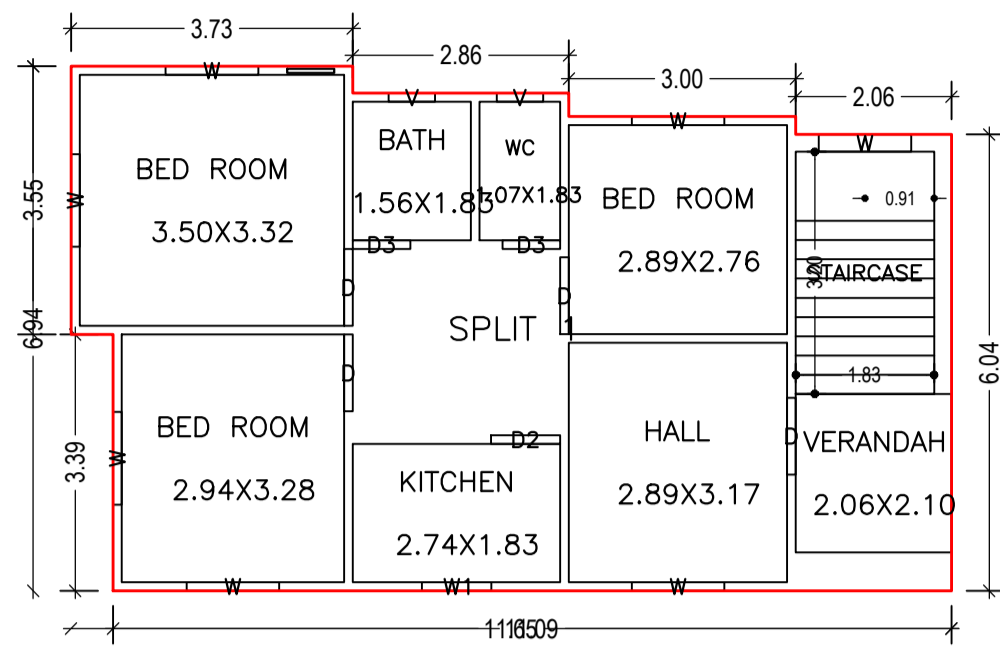

GROUND FLOOR PLAN
(Proposed)
(SCALE 1:100)

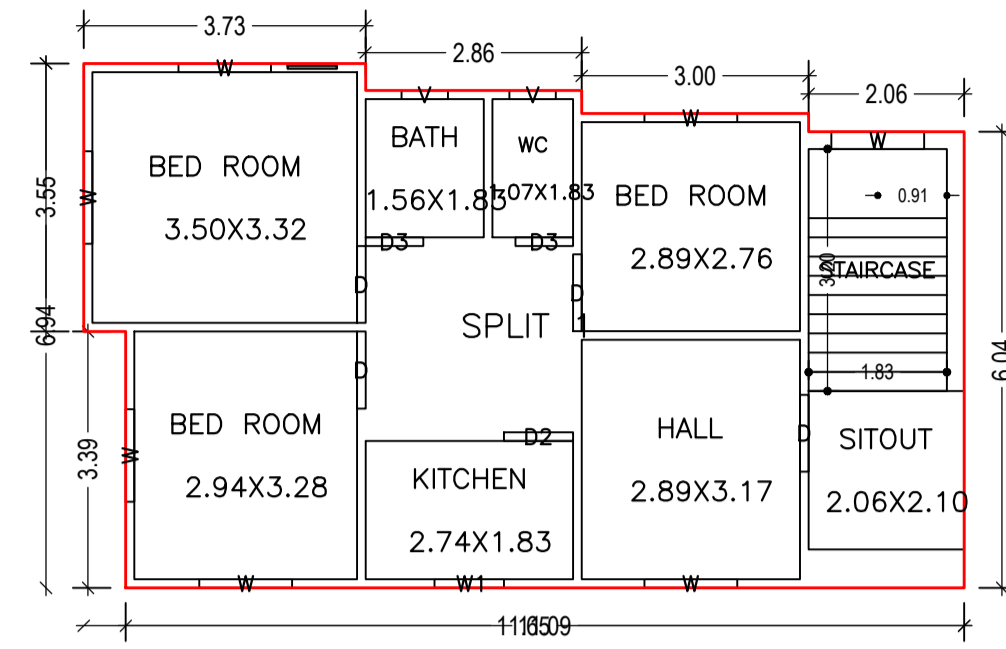

FIRST FLOOR PLAN
(Proposed)
(SCALE 1:100)

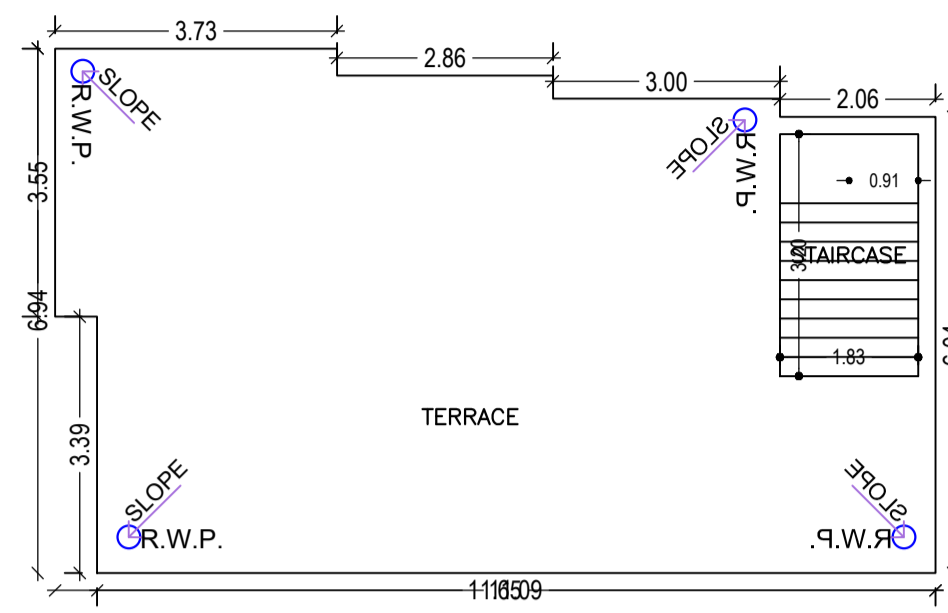

TERRACE FLOOR PLAN
(SCALE 1:100)

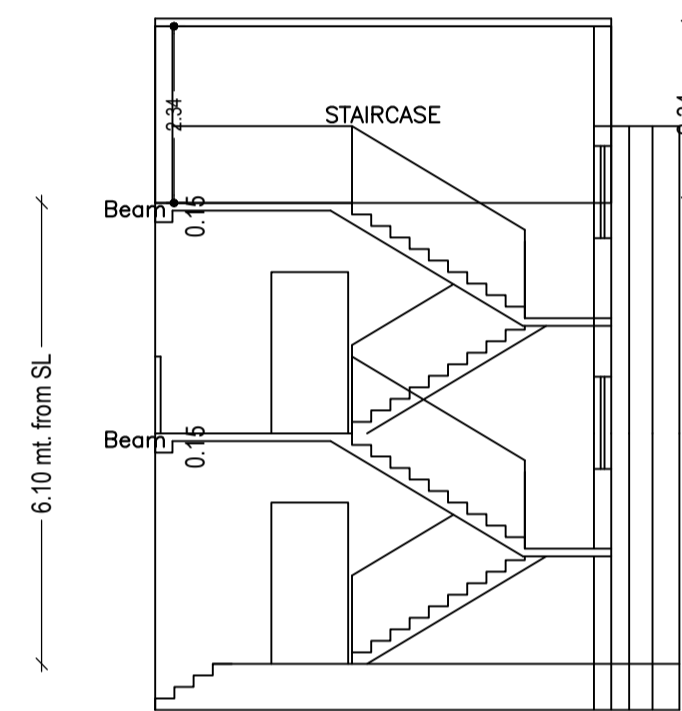

SECTION ON X-X

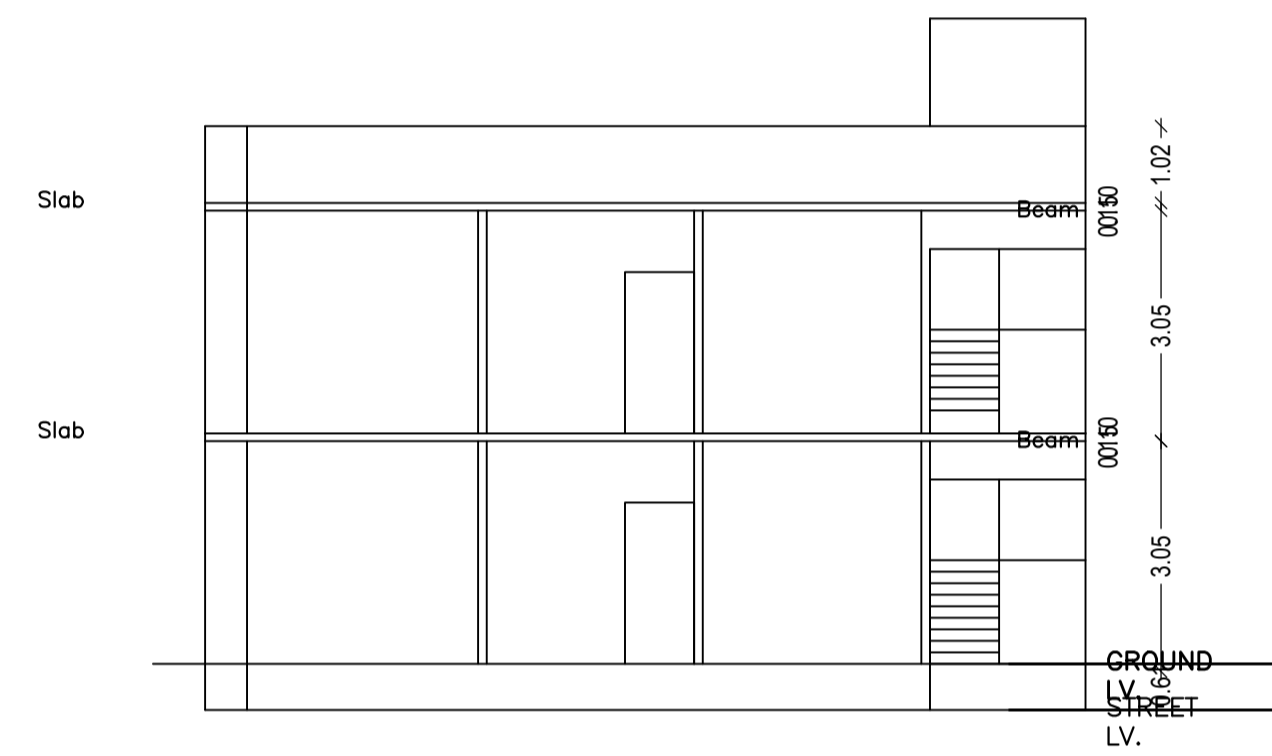

SECTION ON Y-Y

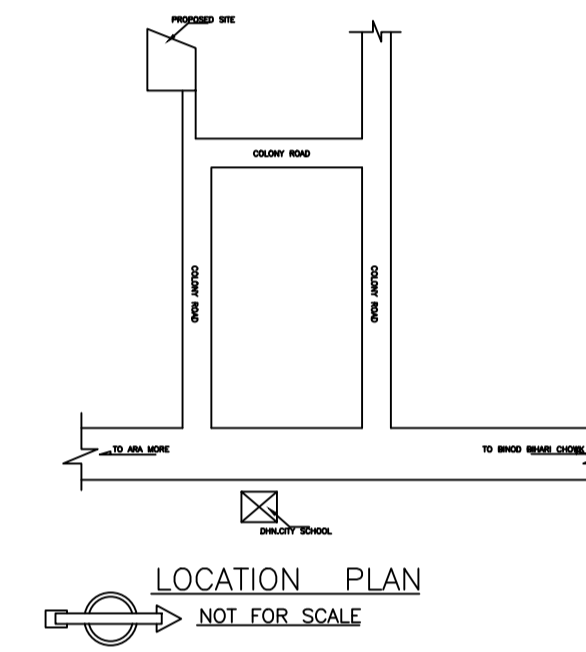

LOCATION PLAN
NOT FOR SCALE

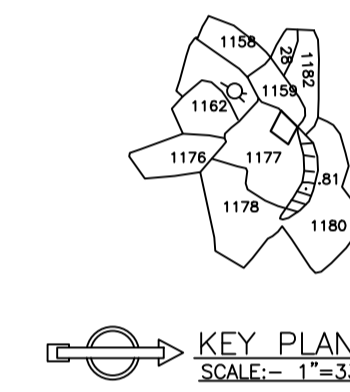

KEY PLAN
SCALE: 1"=330''

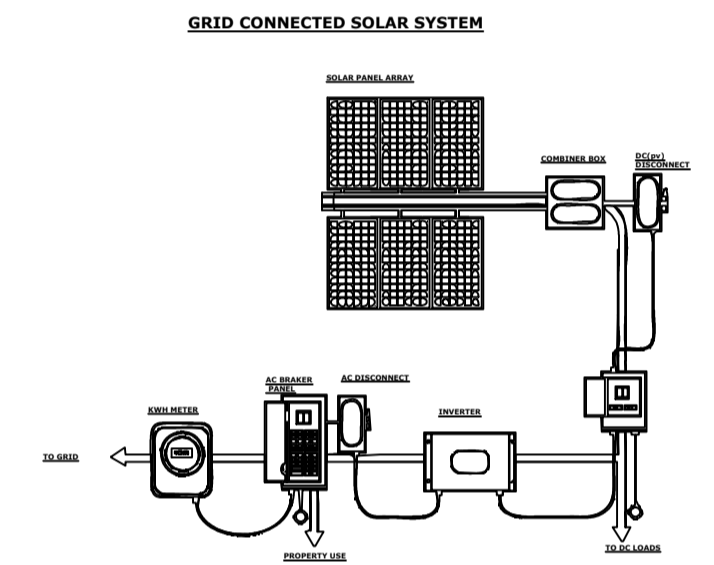

GRID CONNECTED SOLAR SYSTEM

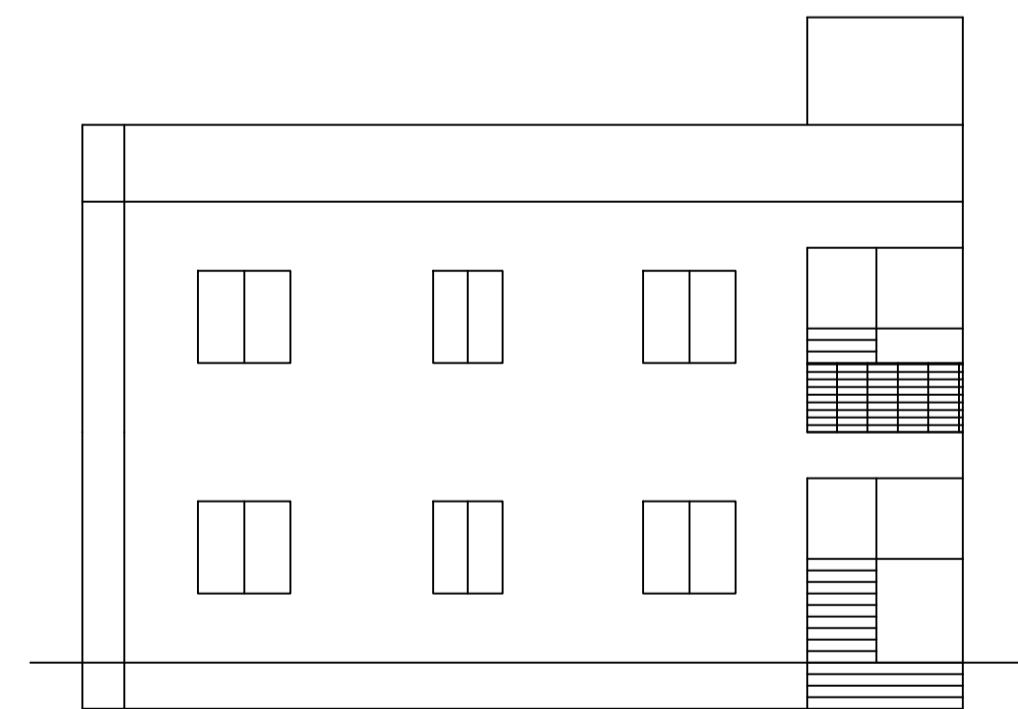

FRONT ELEVATION

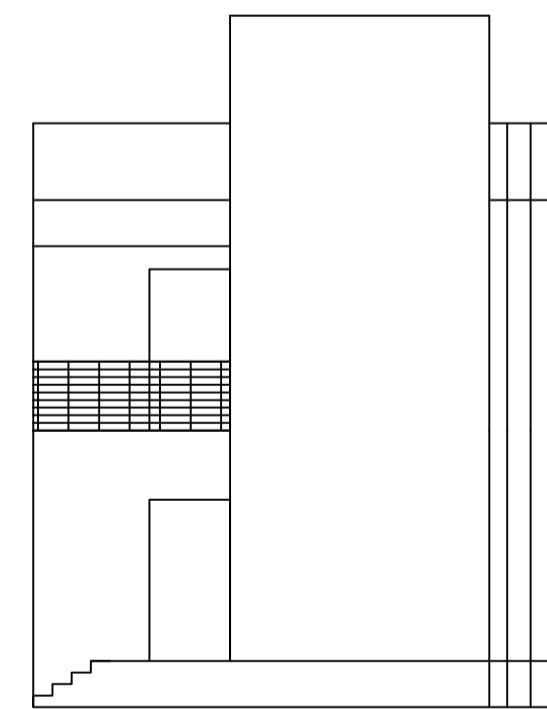

RIGHT SIDE
ELEVATION

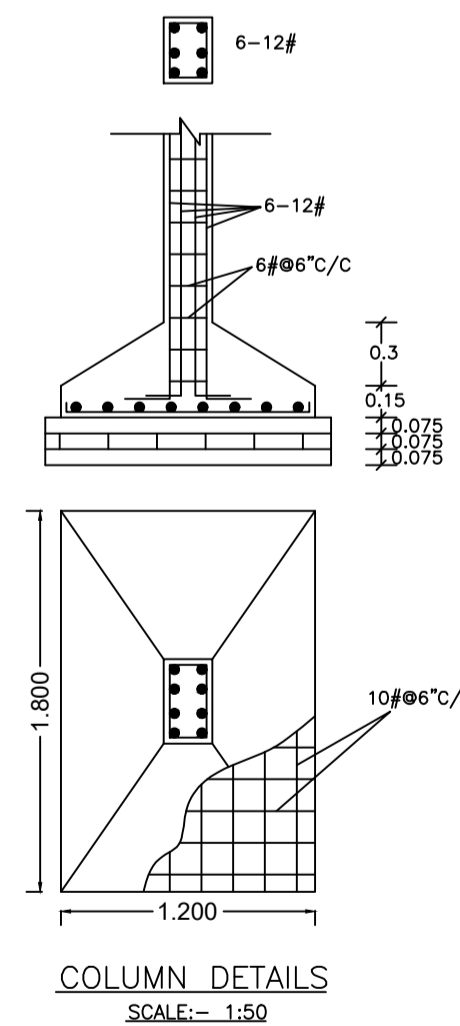

COLUMN DETAILS
SCALE: 1:50

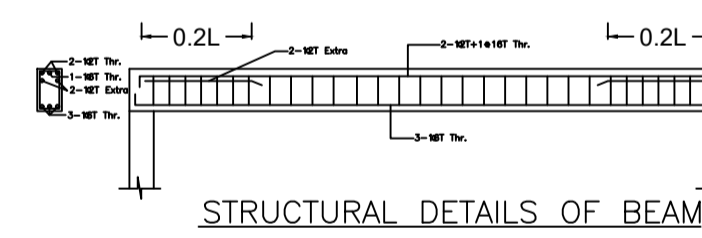

STRUCTURAL DETAILS OF BEAM

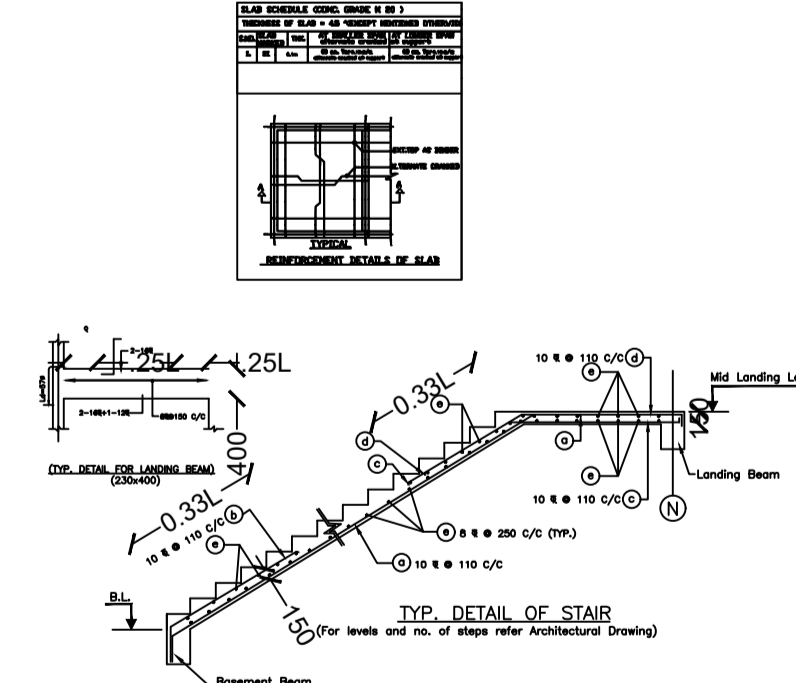

TYP. DETAIL OF STAIR
(For levels and no. of steps refer Architectural Drawing)

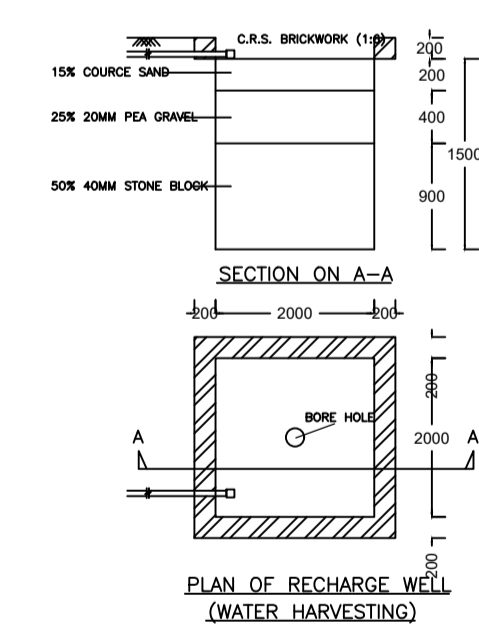

SECTION ON A-A

PLAN OF RECHARGE WELL
(WATER HARVESTING)

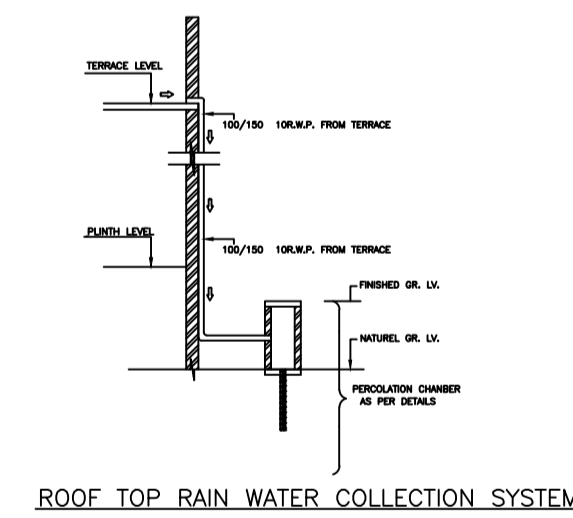

ROOF TOP RAIN WATER COLLECTION SYSTEM

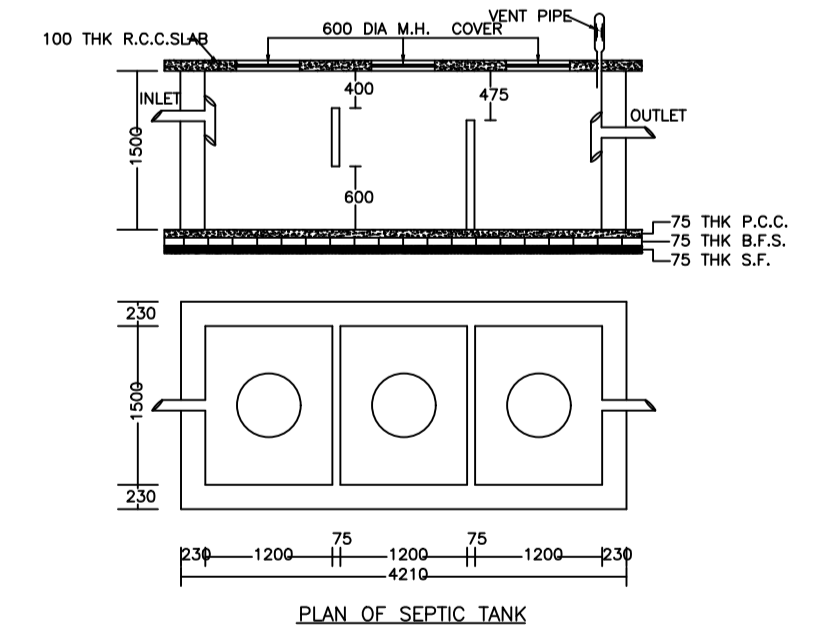

PLAN OF SEPTIC TANK

LTP NAME AND SIGNATURE	STRUCTURAL ENG'S NAME AND SIGNATURE	BUILDER NAME AND SIGNATURE	DIGITAL SIGNATURE
PIYUSH KANTI SINGH DMC/ENG/0020/2016			