

SITE PLAN

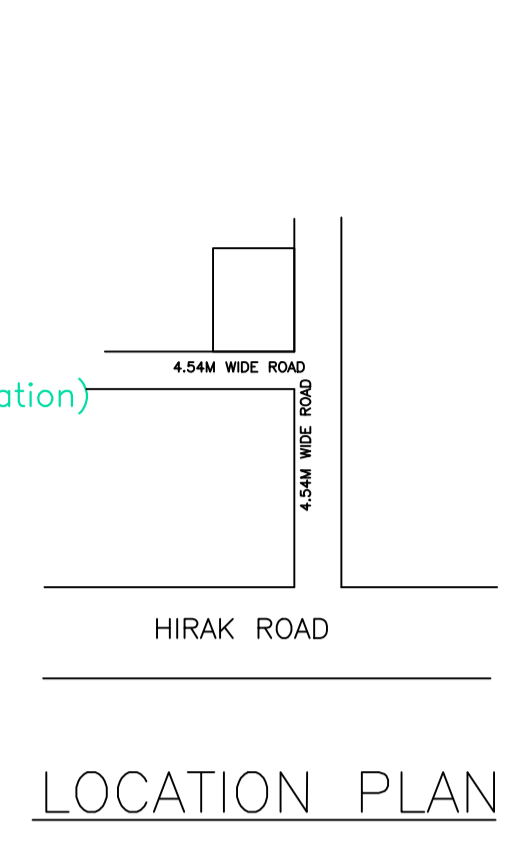

LOCATION PLAN

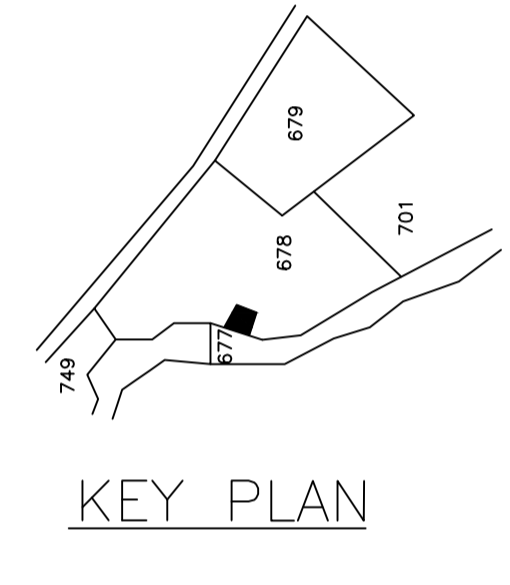

KEY PLAN

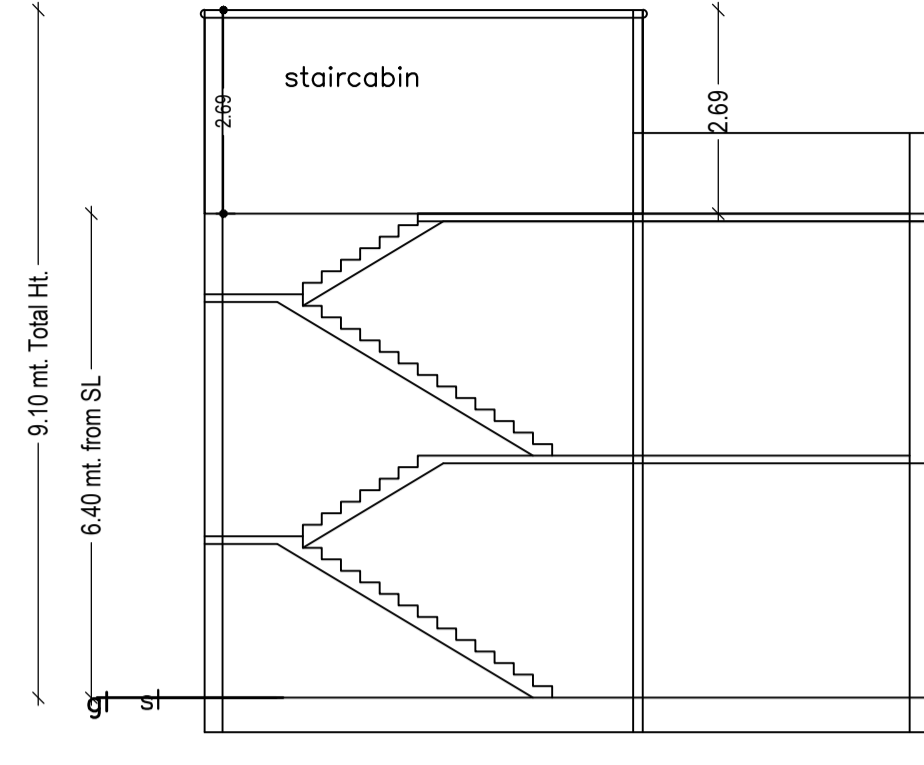

SECTION ON X-X

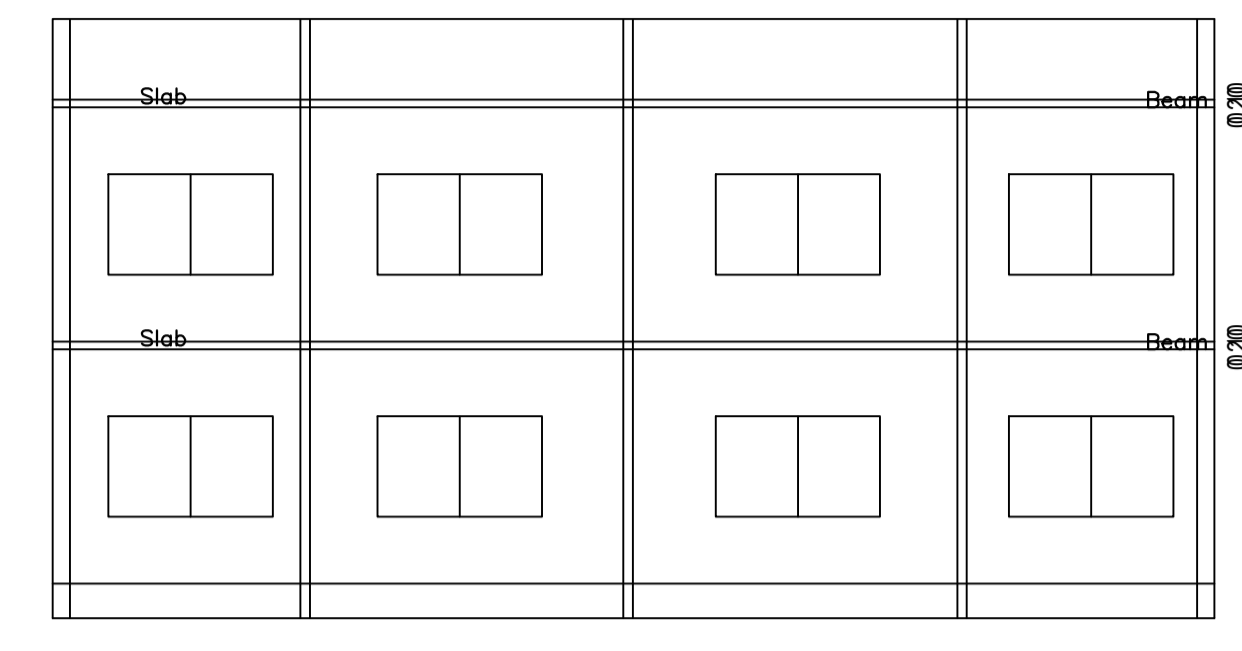

SECTION ON Y-Y

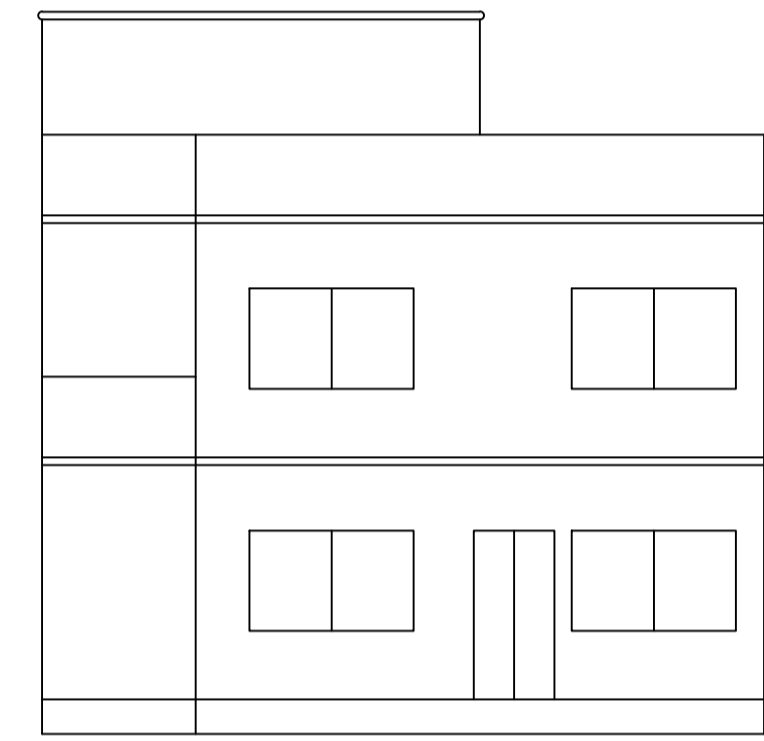

FRONT ELEVATION

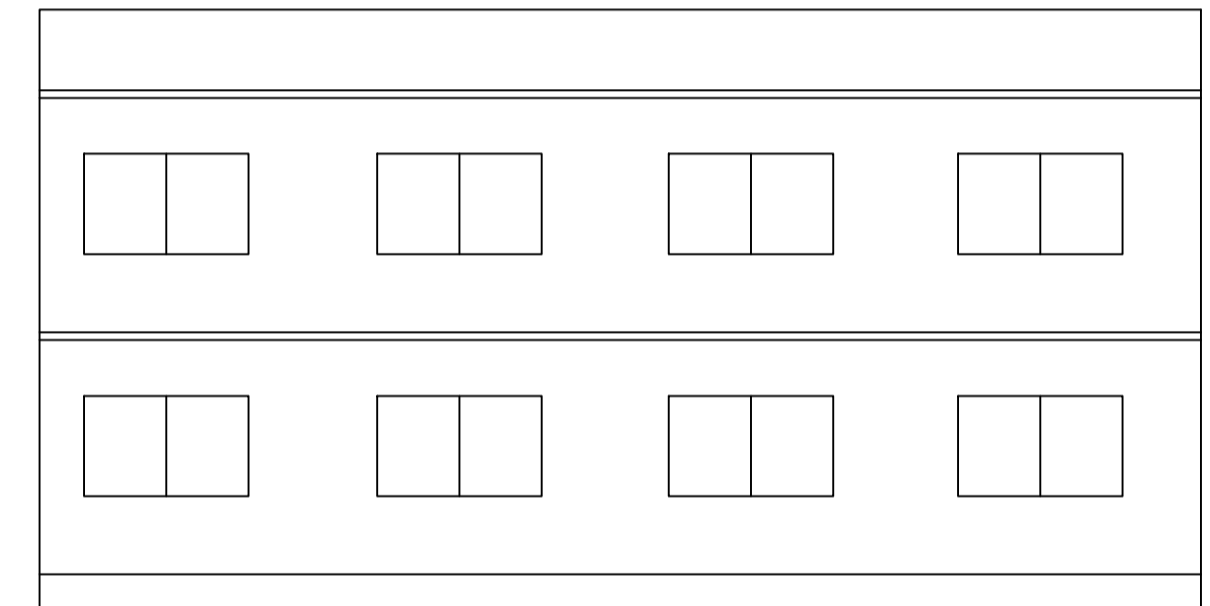

SIDE ELEVATION

site plan

Building Name	Name	Length	Height	NOS
A (A)	d	0.90	2.10	22

SCHEDULE OF DOOR:

Building Name	Name	Length	Height	NOS
A (A)	w	1.15	1.20	02
A (A)	w	1.80	1.20	26

SCHEDULE OF WINDOW/VENTILATION:

Building Name	Name	Length	Height	NOS
A (A)	w	1.15	1.20	02
A (A)	w	1.80	1.20	26

Building :A (A)

Floor Name	Total Built Up Area (Sq.mt.)	Proposed FAR Area (Sq.mt.)	Total FAR Area (Sq.mt.)	Total Consumed Additional FAR Area (Sq.mt.)	Tnmt (No.)
Ground Floor	140.43	140.43	140.43	140.43	01
First Floor	140.43	140.43	140.43	140.43	00
Terrace Floor	0.00	0.00	0.00	0.00	00
Total :	280.86	280.86	280.86	280.86	01
Total Number of Same Buildings :	1				
Total :	280.86	280.86	280.86	280.86	01

FAR & Tenement Details (Table 4c-1)

Building	No. of Same Bldg	Total Built Up Area (Sq.mt.)	Proposed FAR Area (Sq.mt.)	Total FAR Area (Sq.mt.)	Total Consumed Additional FAR Area (Sq.mt.)	Tnmt (No.)
A (A)	1	280.86	280.86	280.86	280.86	01
Grand Total :	1	280.86	280.86	280.86	280.86	01

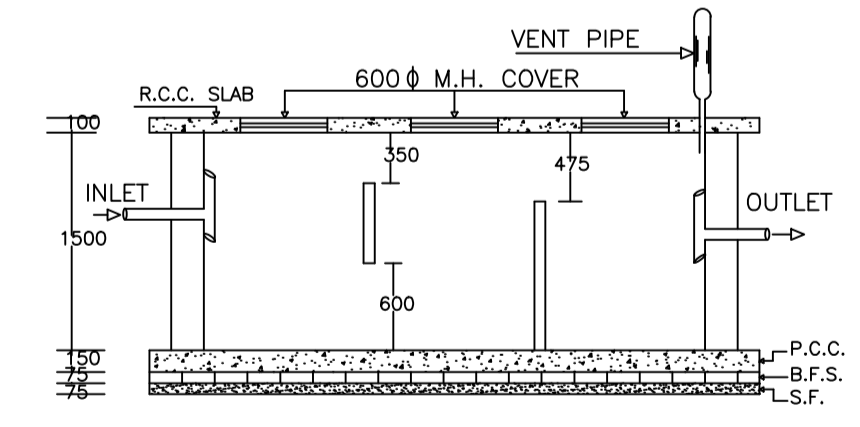

PLAN OF SEPTIC TANK

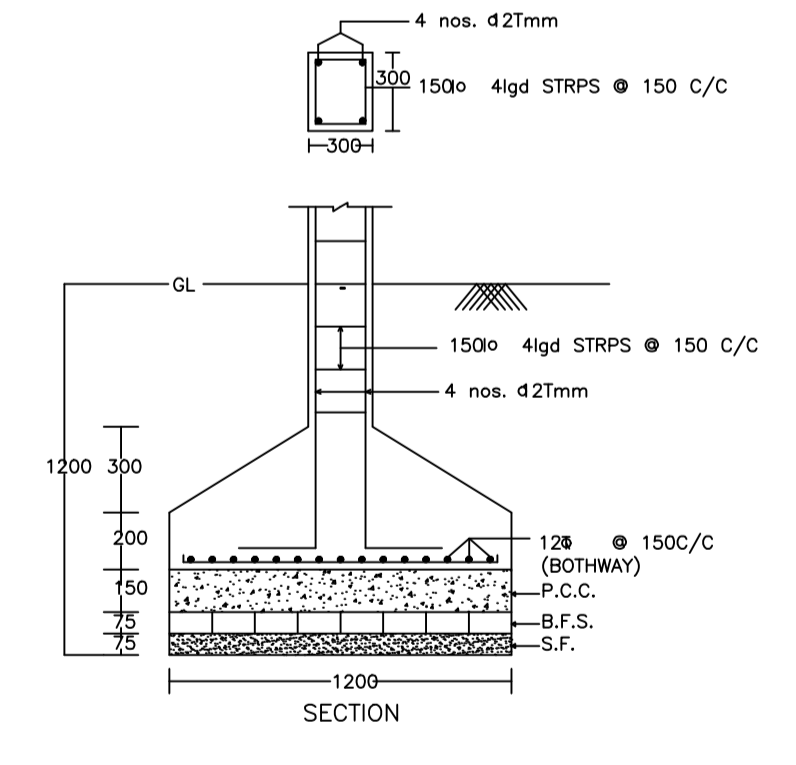

DETAIL OF COLUMNS

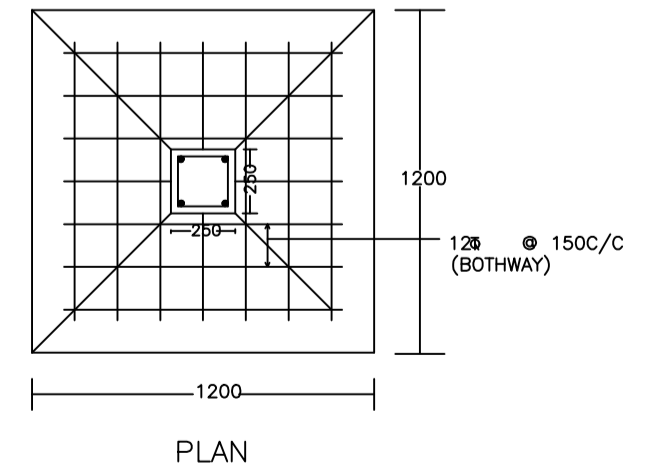

PLAN

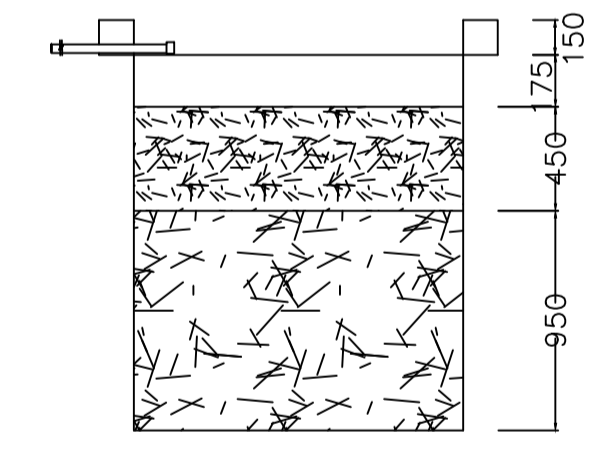

SECTION AT Y-Y

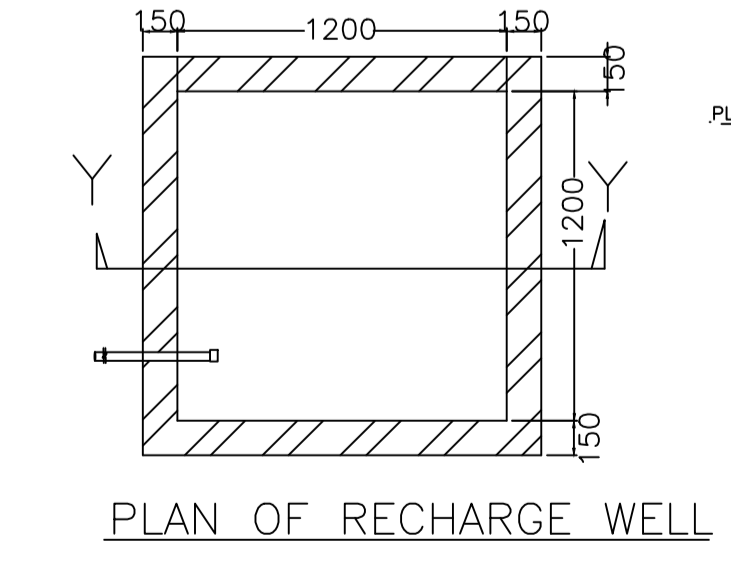

PLAN OF RECHARGE WELL

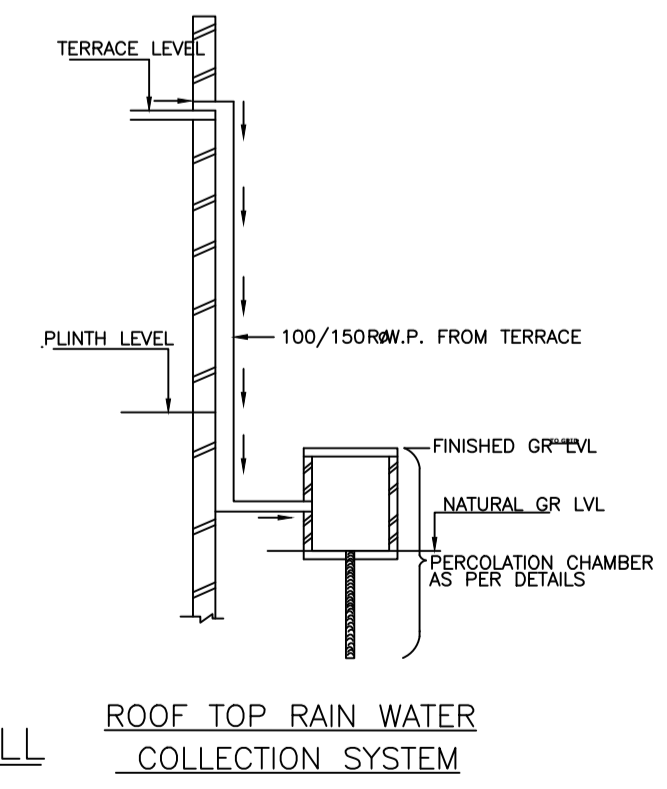

ROOF TOP RAIN WATER COLLECTION SYSTEM

Proposal Basic Information

Proposal File No.	DMC/BP/0144/W23/2022
Owner Name	SWAMI NATH PRASAD
Khata No	45(new : 71)
Plot No	678(new : 877)
Village Name	Sabalpur
Use	Residential
SubUse	Bungalow/ Dwelling / Non Apartment

AREA STATEMENT

AREA OF PLOT (Minimum)	(A)	SQ.MT.
Area of Plot	(A)	236.72
Deduction for NetPlot Area		
Surrender Free of Cost		3.18
Total		3.18
NET AREA OF PLOT(Gross Plot Area - Deduction from Gross Plot area)	(A-Deductions)	233.54
Deduction for Balance Plot Area(from Gross Plot Area)		
Surrender Free of Cost		3.18
Common Plot		28.39
Total		31.57
BALANCE AREA OF PLOT(Net Plot Area - Recreational/Amenity space)	(A-Deductions)	205.15
PLOT AREA FOR COVERAGE(Net Plot Area)	(A-Deductions)	233.54
Plot Area for FAR (Net Plot Area + RoadWidening Area)	(A-Deductions)	236.72
COVERAGE CHECK		
Permissible Coverage area (70.00 %)		163.48
Proposed Coverage Area (60.13 %)		140.43
Total Prop. Coverage Area (60.13 %)		140.43
Balance coverage area (9.87 %)		23.05
FAR CHECK		
Perm. FAR Area (1.80)		426.10
Total Perm. FAR area		426.10
Residential FAR		280.85
Proposed FAR Area		280.85
Total Proposed FAR Area		280.85
Consumed FAR (Factor)		1.19
Balance FAR Area		145.25
BUILT UP AREA CHECK		
Total Proposed BuiltUp Area		280.86
ARCHITECT (Regd)		AJAY KUMAR KESARI
ENGINEER (Regd)		
SUPERVISOR (Regd)		
OWNER (Regd)		SWAMI NATH PRASAD
DEVELOPMENT AUTHORITY		LOCAL BODY

COLOR INDEX

PLOT BOUNDARY	Black
ABUTTING ROAD	Green
PROPOSED CONSTRUCTION	Red
COMMON PLOT	Yellow
ROAD WIDENING AREA	Orange
EXISTING (To be retained)	Blue
EXISTING (To be demolished)	Light Blue

Buildingwise Floor FAR Details

Floor Name	Building Name A (A)		Total	
	Proposed Built Up Area (Sq.mt.)	Proposed FAR Area (Sq.mt.)	Total Proposed Built Up Area (Sq.mt.)	Total FAR Area (Sq.mt.)
Ground Floor	140.43	140.43	140.43	140.43
First Floor	140.43	140.43	140.43	140.43
Terrace Floor	0.00	0.00	0.00	0.00
Total :	280.86	280.86	280.86	280.86

Building USE/SUBUSE Details

Building Name	Building Use	Building SubUse	Building Structure
A (A)	Residential	Residential Bldg/Apartment	Non-Highrise

UnitBUA Table for Building :A (A)

FLOOR	Name	UnitBUA Type	UnitBUA Area	Carpet Area	No. of Rooms	No. of Tenement
GROUND FLOOR PLAN	SPLIT 1	FLAT	280.85	280.79	10	1
FIRST FLOOR PLAN	SPLIT 1	FLAT	0.00	0.00	10	0
Total:	-	-	280.85	280.79	20	1

LTP NAME AND SIGNATURE	STRUCTURAL ENG'S NAME AND SIGNATURE	BUILDER NAME AND SIGNATURE	DIGITAL SIGNATURE
AJAY KUMAR KESARI DMC/ENG/0007/2021			

Proposal Basic Information

Proposal File No.	DMC/BP/0144/W23/2022
Owner Name	SWAMI NATH PRASAD
Khata No	45(new : 71)
Plot No	678(new : 877)
Village Name	Sabalpur
Use	Residential
SubUse	Bungalow/ Dwelling / Non Apartment

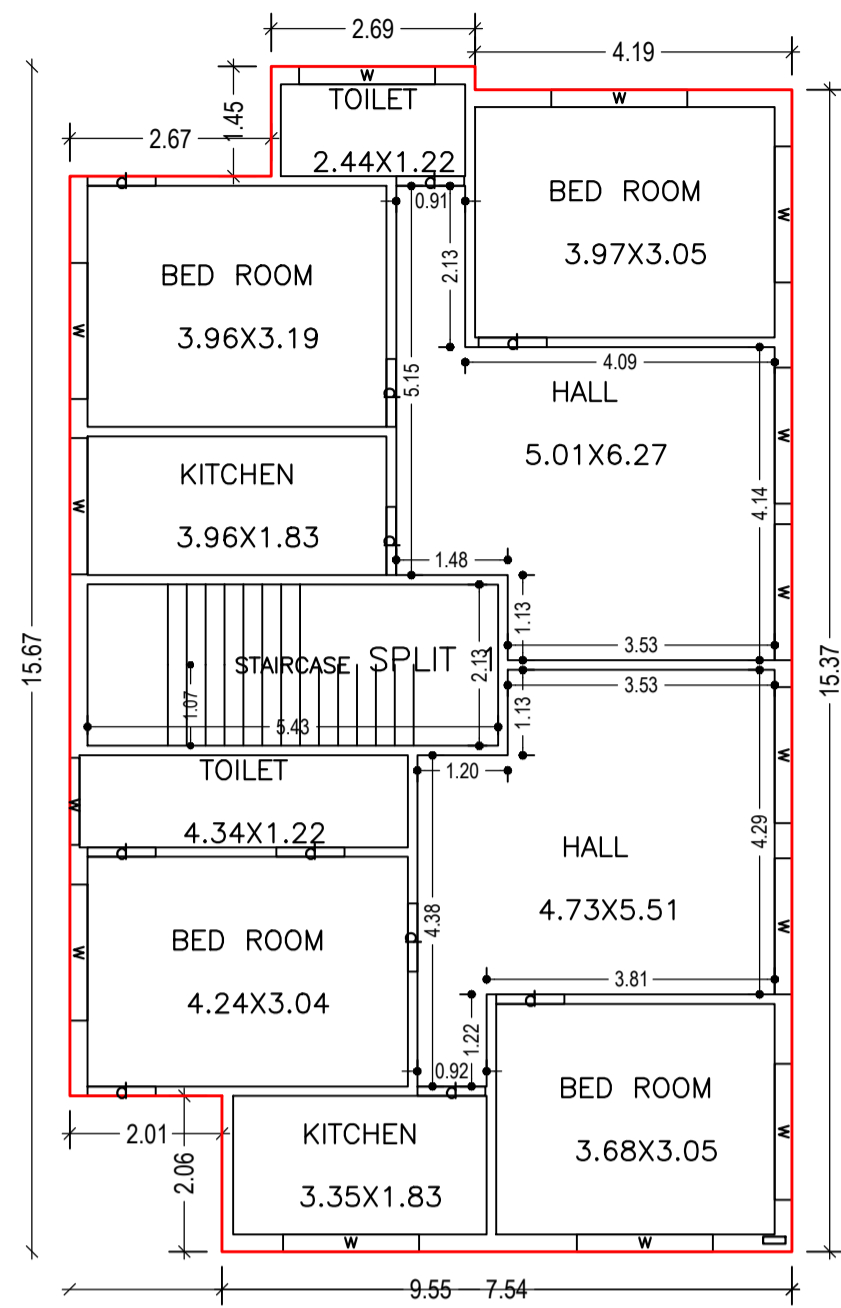

GROUND FLOOR PLAN
(Proposed)
(SCALE 1:100)

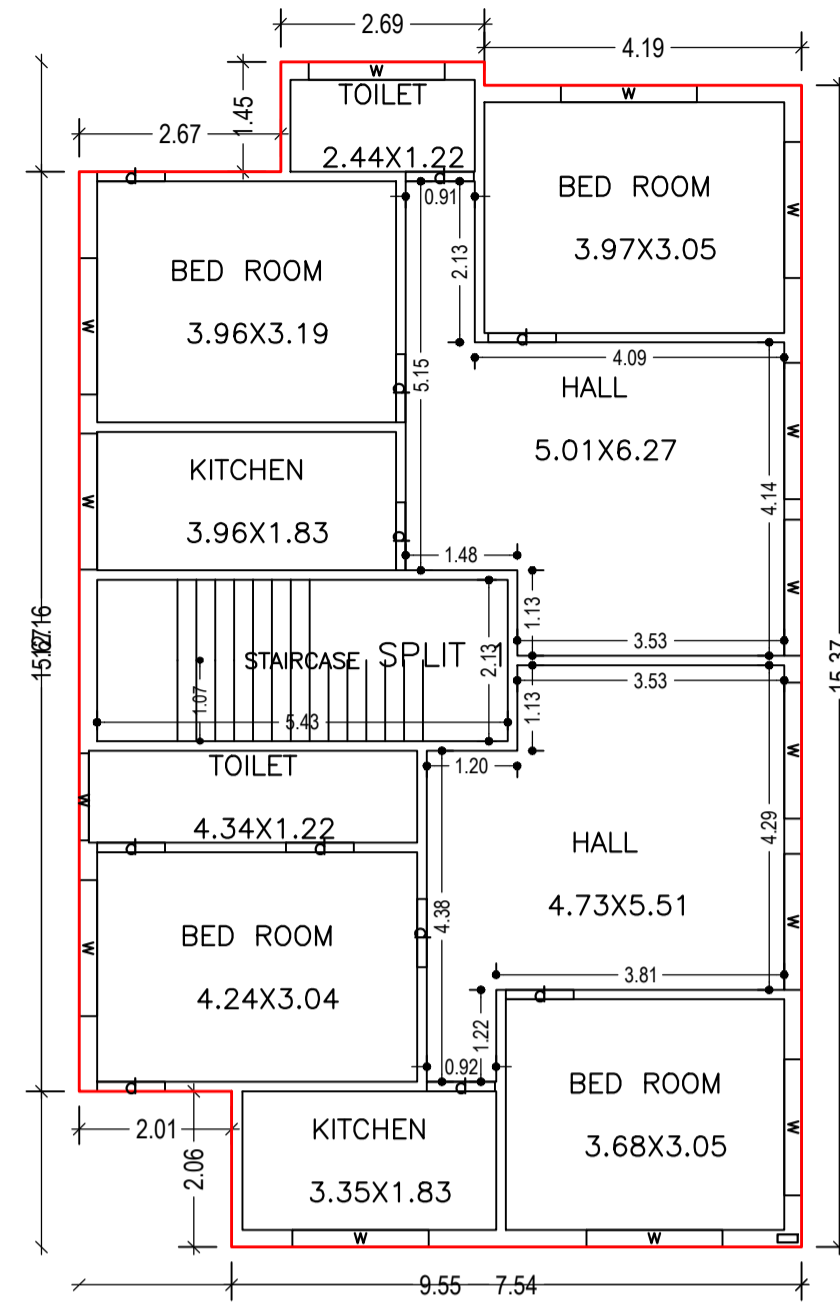

FIRST FLOOR PLAN
(Proposed)
(SCALE 1:100)

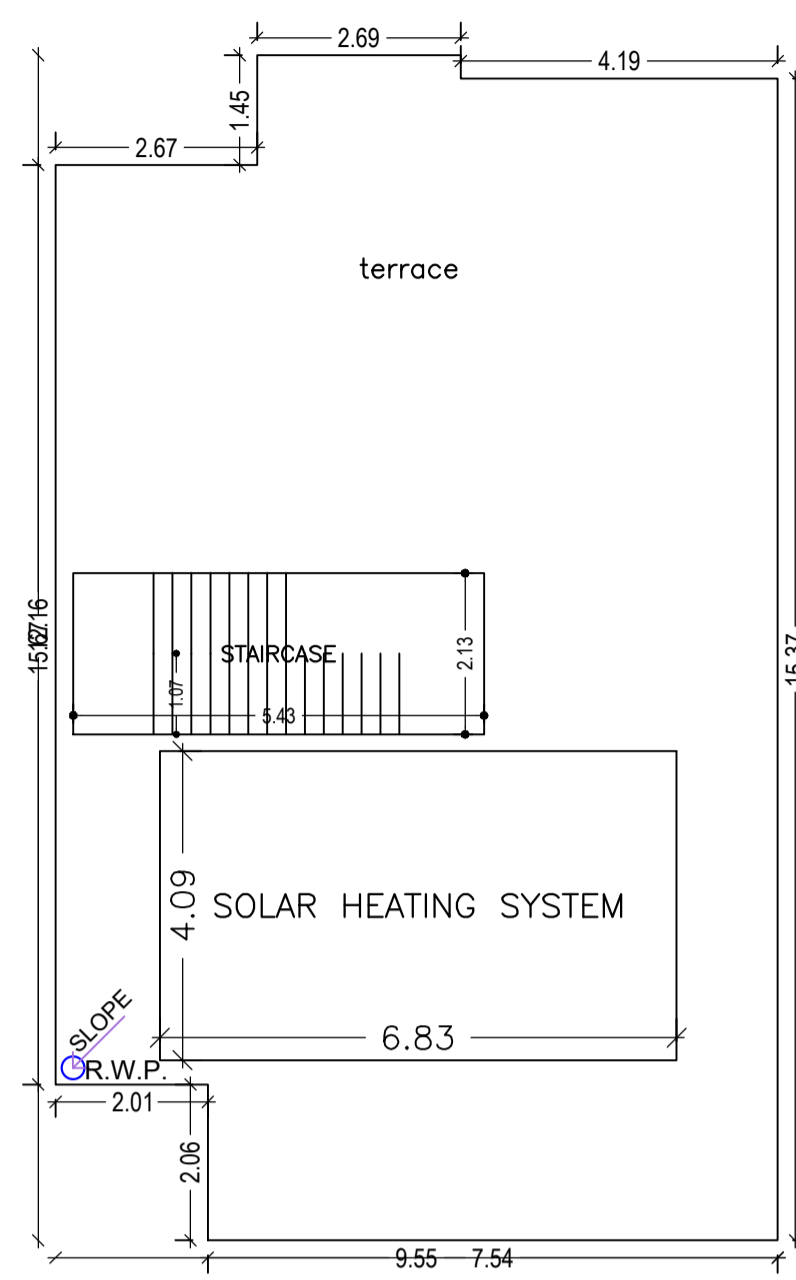

TERRACE FLOOR PLAN
(SCALE 1:100)

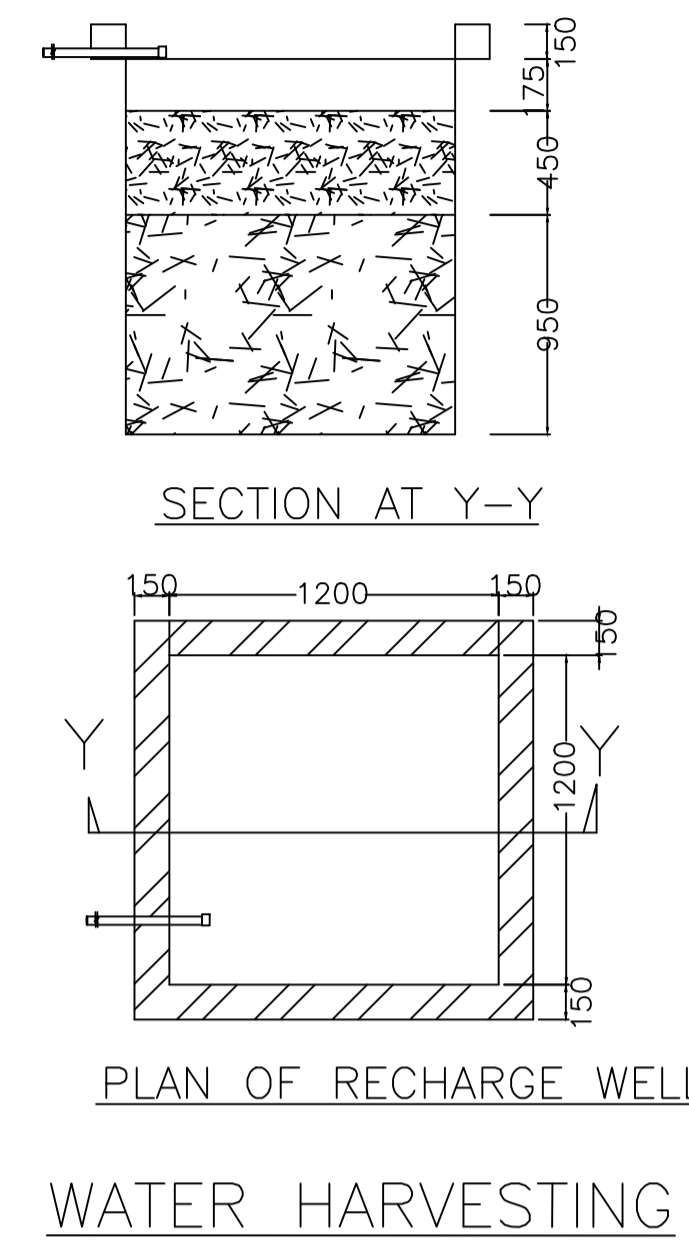

WATER HARVESTING

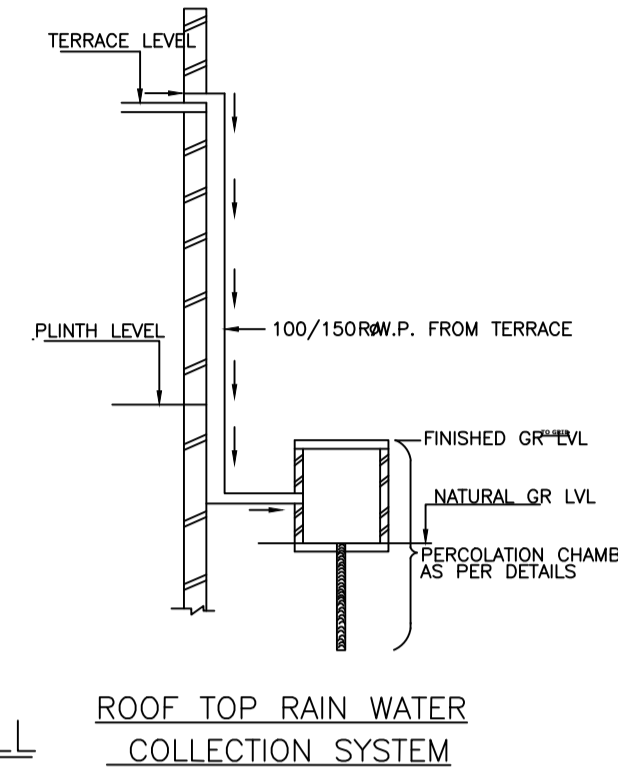

ROOF TOP RAIN WATER
COLLECTION SYSTEM

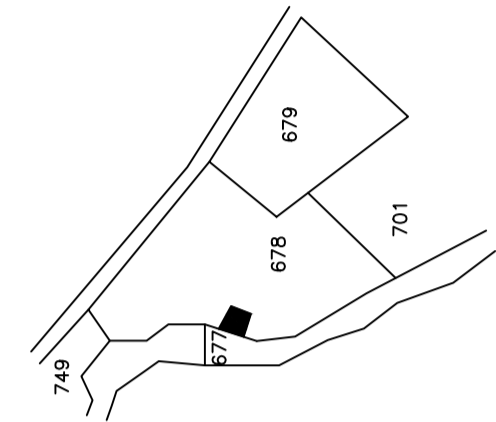

KEY PLAN

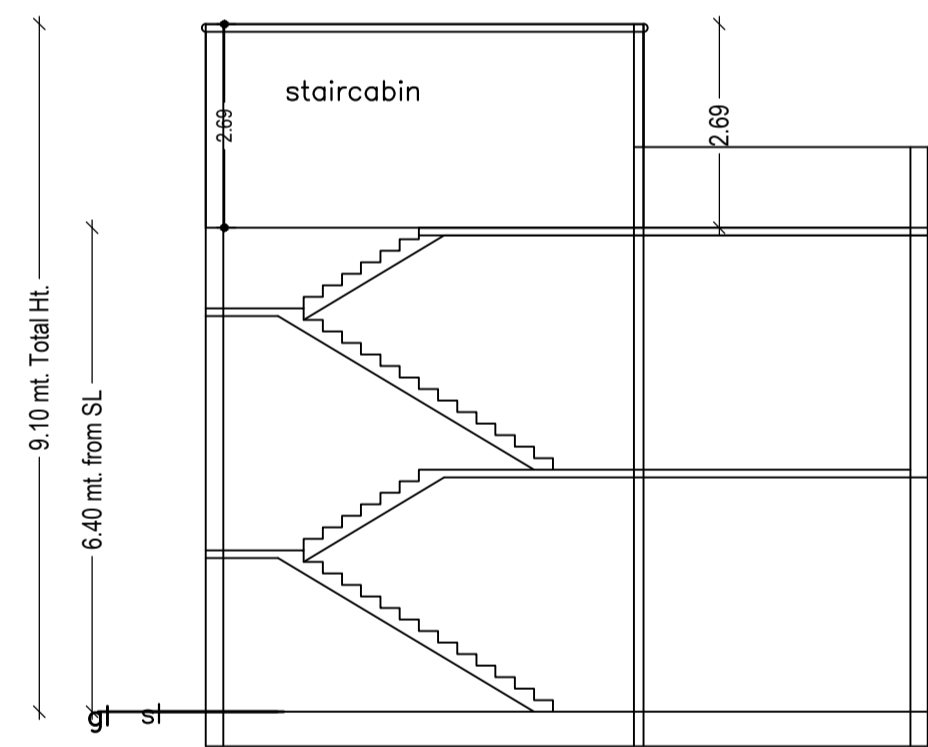

SECTION ON X-X

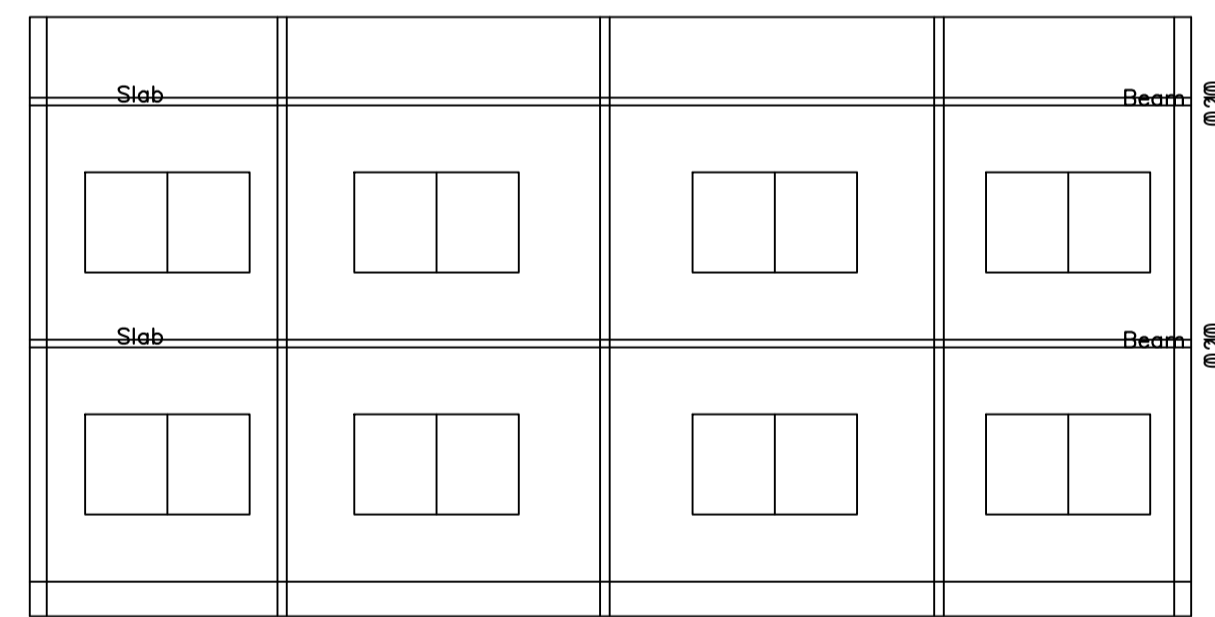

SECTION ON Y-Y

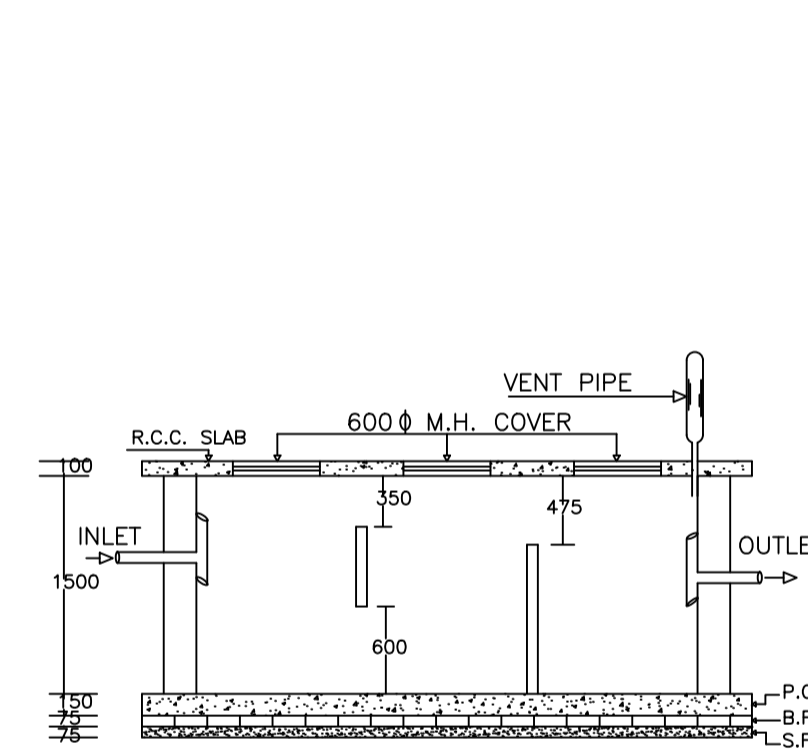

PLAN OF SEPTIC TANK

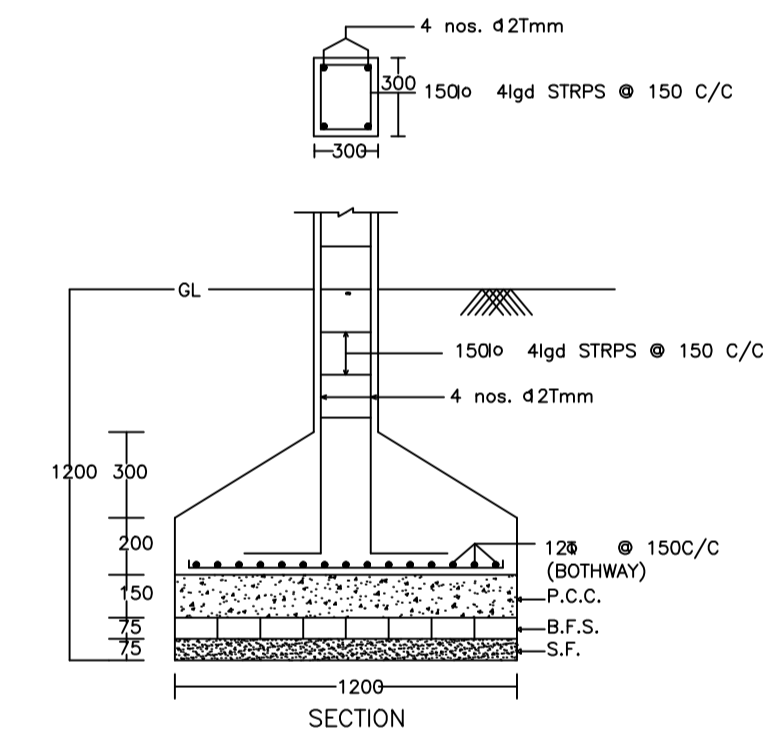

DETAIL OF COLUMNS

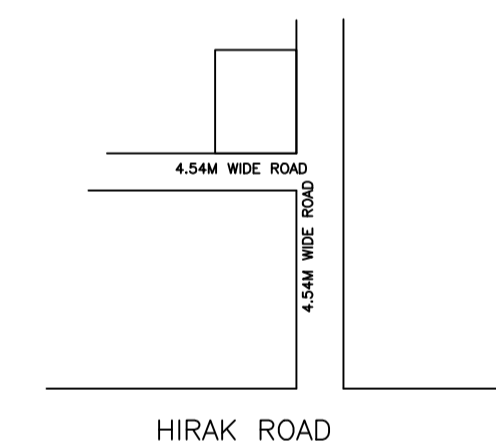

LOCATION PLAN

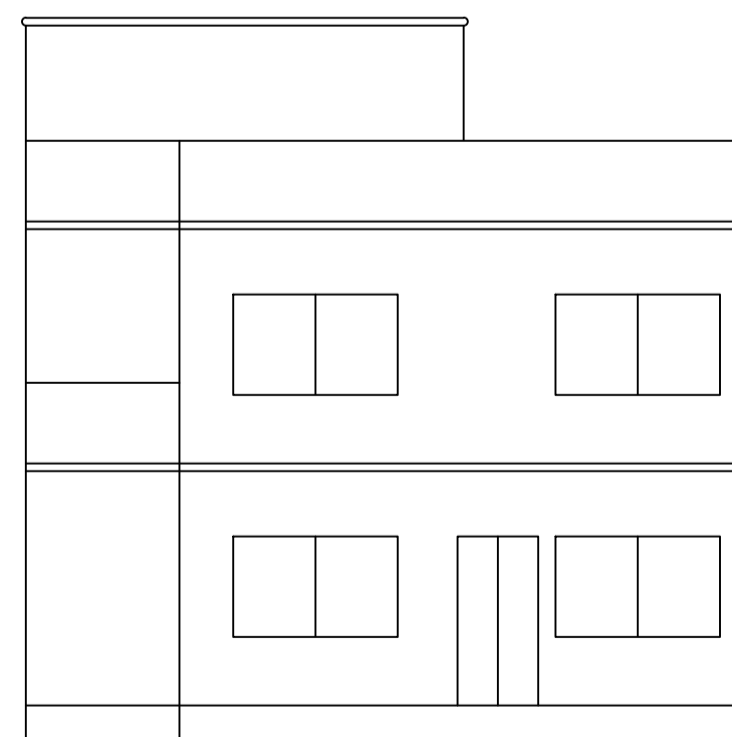

FRONT ELEVATION

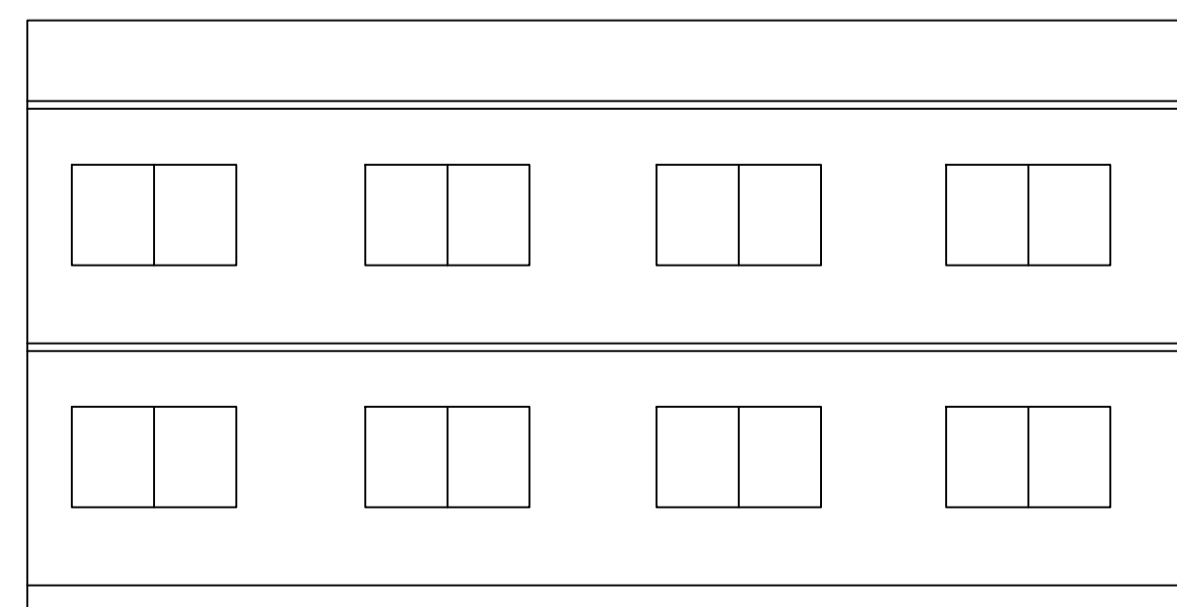

SIDE ELEVATION

LTP NAME AND SIGNATURE AJAY KUMAR KESARI DMC/ENG/0007/2021	STRUCTURAL ENG'S NAME AND SIGNATURE	BUILDER NAME AND SIGNATURE	DIGITAL SIGNATURE
--	-------------------------------------	----------------------------	-------------------