

Proposal Basic Information	
Proposal File No.	DMC/BP/0112/W23/2022
Owner Name	SRI KAUSHAL KISHOR SINGH
Khata No	OLD 41, NEW 199
Plot No	OLD 1942, NEW 2550/4971
Village Name	Kolakusma
Use	Residential
SubUse	Bungalow/ Dwelling / Non Apartment

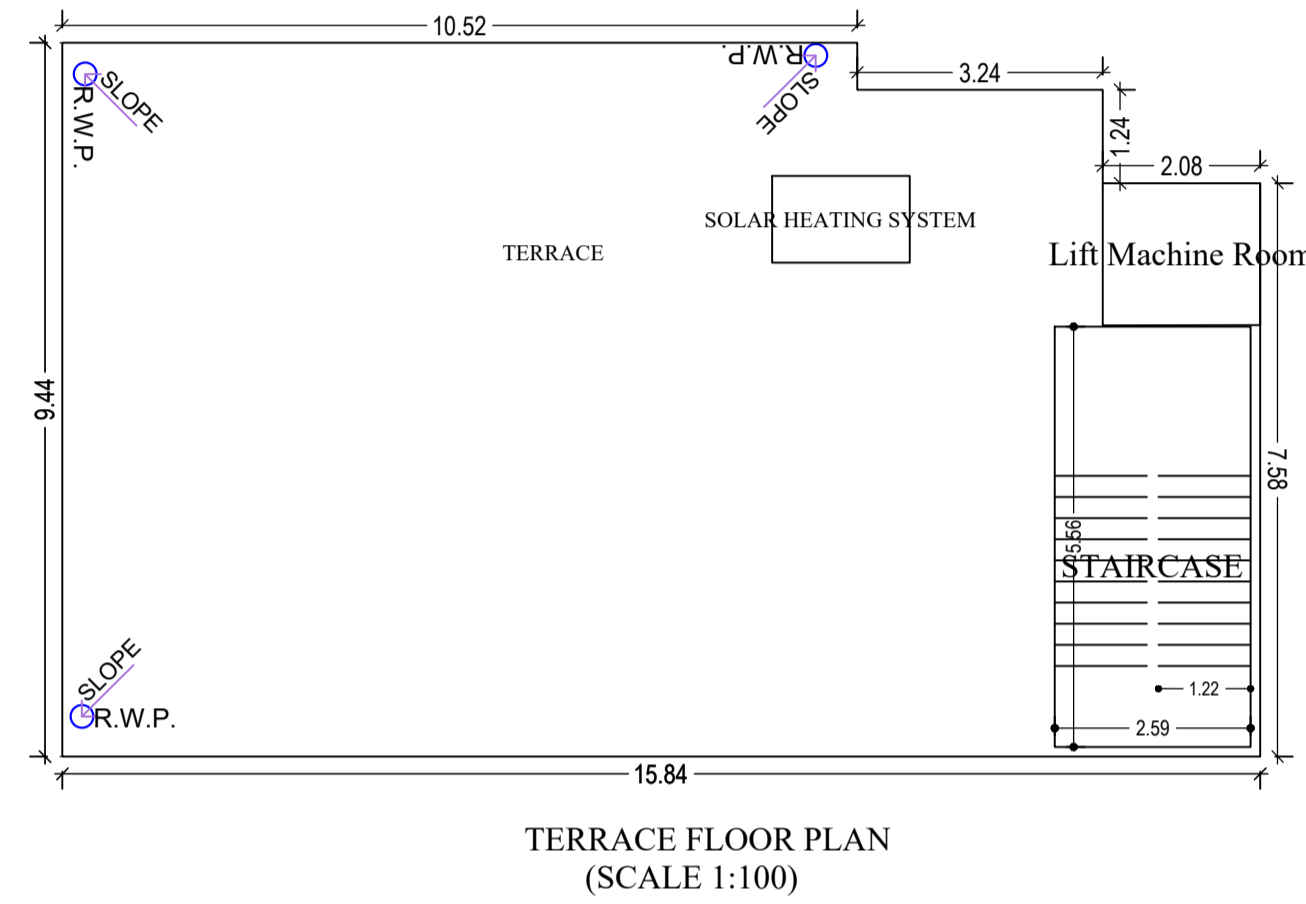
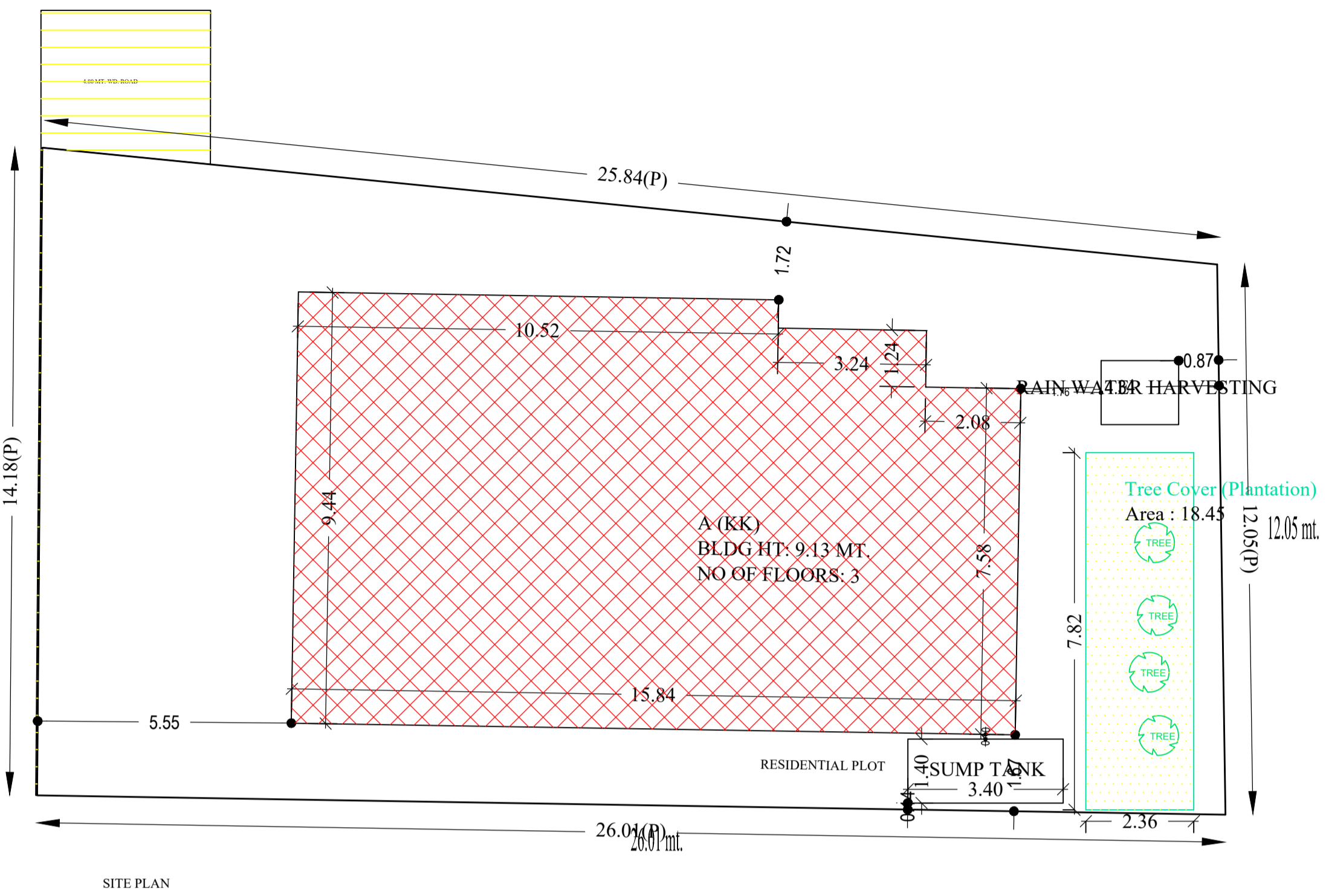

AREA STATEMENT		VERSION NO. : 1.0.62
DHANBAD MUNICIPAL CORPORATION		VERSION DATE: 16/10/2020
PROJECT DETAIL:		
Region: JHARKHAND URBAN LOCAL BODIES	Plot Use: Residential	
District: DHANBAD	Plot SubUse: Bungalow/ Dwelling / Non Apartment	
Authority: DHANBAD MUNICIPAL CORPORATION	PlotNearby/ReligiousStructure: NA	
Inward No: DMC/BP/0112/W23/2022	Plot/SubPlot No: OLD 1942, NEW 2550/4971	
Application Type: General Proposal	North: Plot No. - PART OF PLOT NO 1942	
Project Type: Building Permission	South: Survey No. - BCLL BOUNDARY	
Nature of Development: New	East: Plot No. - PART OF PLOT NO 1942	
Location of Development Area: Old Area	West: Plot No. - purchaser'S NIZ.	
AREA DETAILS:		
AREA OF PLOT (Minimum)	(A)	SQ.MT. 339.07
NET AREA OF PLOT(Gross Plot Area - Deduction from Gross Plot area)	(A-Deductions)	339.07
Deduction for Balance Plot Area(from Gross Plot Area)		
Common Plot		18.45
Total		18.45
BALANCE AREA OF PLOT(Net Plot Area - Recreational/Amenity space)	(A-Deductions)	320.61
PLOT AREA FOR COVERAGE(Net Plot Area)	(A-Deductions)	339.07
Plot Area for FAR (Net Plot Area + RoadWidening Area)	(A-Deductions)	339.07
COVERAGE CHECK		
Permissible Coverage area (60.00 %)		203.44
Proposed Coverage Area (42.37 %)		143.67
Total Prop. Coverage Area (42.37 %)		143.67
Balance coverage area (17.63 %)		59.77
FAR CHECK		
Perm. FAR Area (1.80)		610.33
Total Perm. FAR area		610.33
Residential FAR		423.19
Proposed FAR Area		423.19
Total Proposed FAR Area		423.19
Consumed FAR (Factor)		1.25
Balance FAR Area		187.14
BUILT UP AREA CHECK		
Total Proposed BuiltUp Area		431.03
ARCHITECT (Regd)		ASHOK KUMAR
ENGINEER (Regd)		
SUPERVISOR (Regd)		
OWNER (Regd)		SRI KAUSHAL KISHOR SINGH
DEVELOPMENT AUTHORITY		LOCAL BODY

Building :A (KK)

Floor Name	Total Built Up Area (Sq.mt.)	Deductions (Area in Sq.mt.)	Proposed FAR Area (Sq.mt.)	Total FAR Area (Sq.mt.)	Total Consumed Additional FAR Area (Sq.mt.)	Trmt (No.)
Ground Floor	143.67	0.00	143.67	143.67	143.67	01
First Floor	143.68	3.92	139.76	139.76	139.76	00
Second Floor	143.68	3.92	139.76	139.76	139.76	00
Terrace Floor	0.00	0.00	0.00	0.00	0.00	00
Total :	431.03	7.84	423.19	423.19	423.19	01
Total Number of Same Buildings :	1					
Total :	431.03	7.84	423.19	423.19	423.19	01

SCHEDULE OF DOOR:

BUILDING NAME	NAME	LENGTH	HEIGHT	NOS
A (KK)	D	0.70	2.10	06
A (KK)	D	0.80	2.10	03
A (KK)	D	0.83	2.10	06
A (KK)	D	1.00	2.10	27

SCHEDULE OF WINDOW/VENTILATION:

BUILDING NAME	NAME	LENGTH	HEIGHT	NOS
A (KK)	V	0.77	1.20	09
A (KK)	W	1.32	1.20	03
A (KK)	W	1.37	1.20	06
A (KK)	w	1.50	1.20	03
A (KK)	w	1.52	1.20	09
A (KK)	w	1.80	1.20	03

UnitBUA Table for Building :A (KK)

FLOOR	Name	UnitBUA Type	UnitBUA Area	Carpet Area	No. of Rooms	No. of Tenement
GROUND FLOOR PLAN	SPLIT 1	FLAT	419.27	419.20	14	1
TYPICAL - 1, 2 FLOOR PLAN	SPLIT 1	FLAT	0.00	0.00	14	0
Total:	-	-	419.27	419.20	42	1

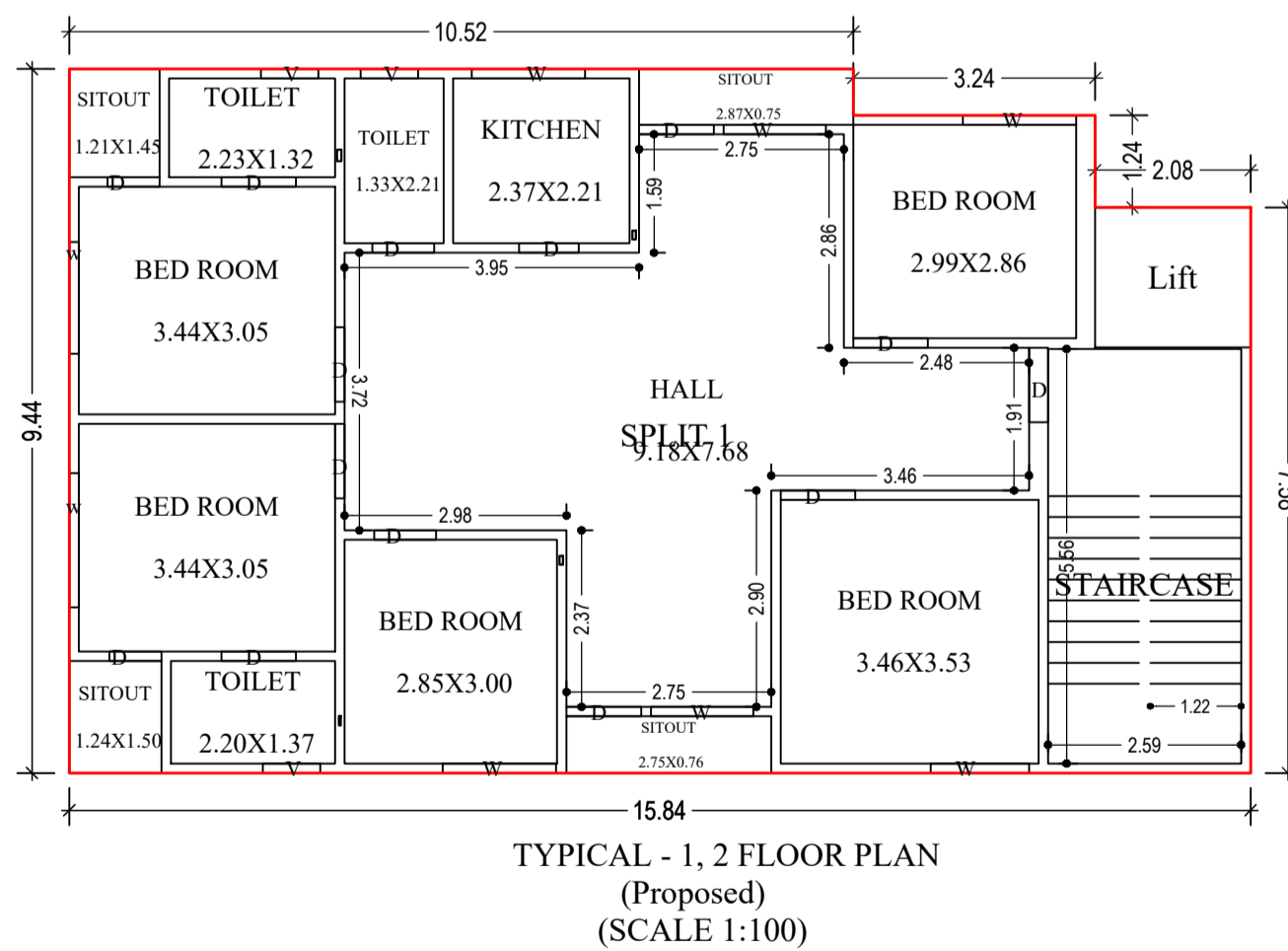
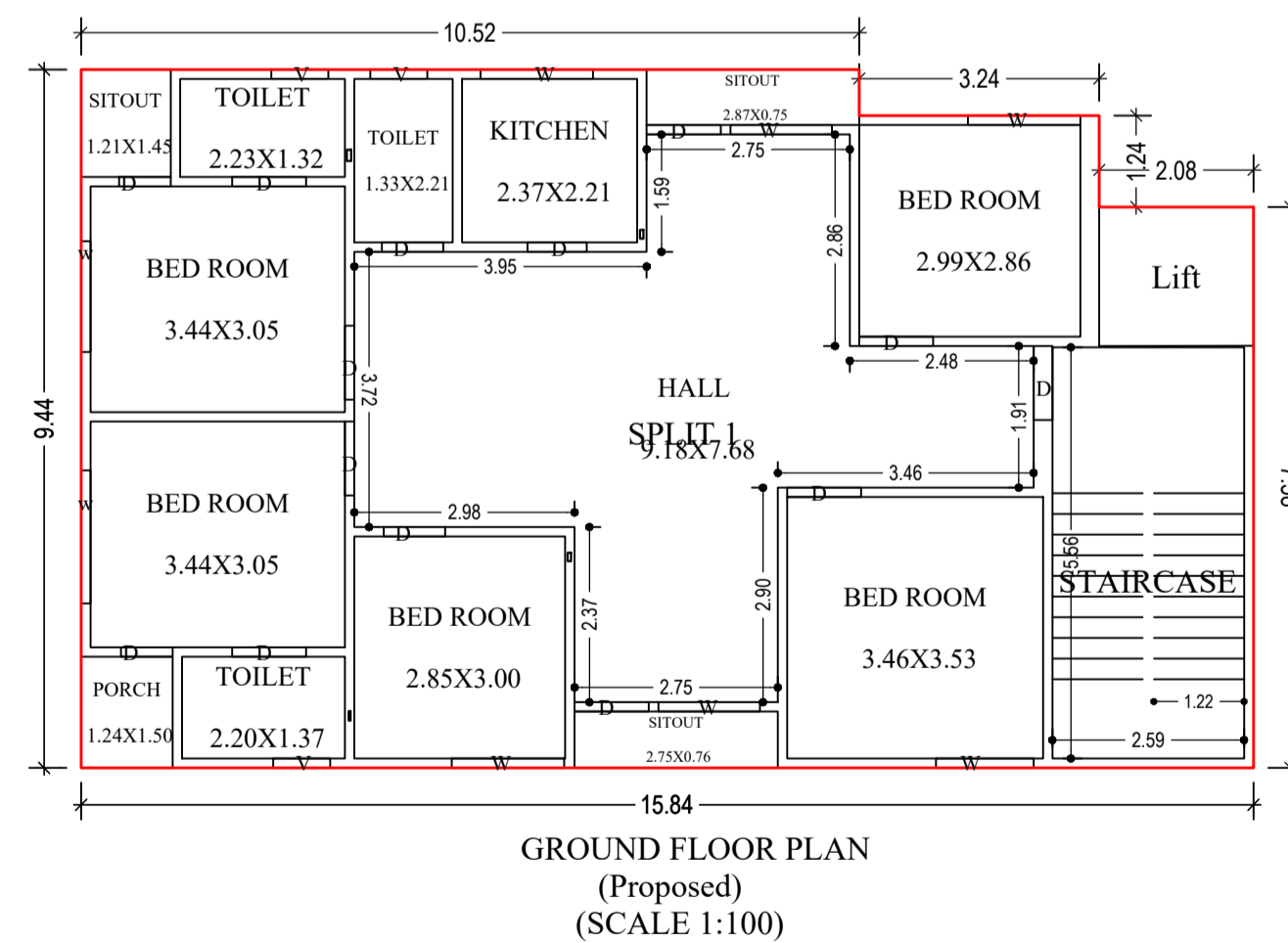

COLOR INDEX	
PLOT BOUNDARY	Black
ABUTTING ROAD	Green
PROPOSED CONSTRUCTION	Red
COMMON PLOT	Yellow
ROAD WIDENING AREA	Blue
EXISTING (To be retained)	Light Blue
EXISTING (To be demolished)	Dark Blue

Buildingwise Floor FAR Details

Floor Name	Building Name A (KK)		Total	
	Proposed Built Up Area (Sq.mt.)	Proposed FAR Area (Sq.mt.)	Total Proposed Built Up Area (Sq.mt.)	Total FAR Area (Sq.mt.)
Ground Floor	143.67	143.67	143.67	143.67
First Floor	143.68	139.76	143.68	139.76
Second Floor	143.68	139.76	143.68	139.76
Terrace Floor	0.00	0.00	0.00	0.00
Total :	431.03	423.19	431.03	423.19

Building USE/SUBUSE Details

Building Name	Building Use	Building SubUse	Building Structure
A (KK)	Residential	Bungalow/ Dwelling / Non Apartment	Non-Highrise

FAR & Tenement Details (Table 4c-1)

Building	No. of Same Bldg	Total Built Up Area (Sq.mt.)	Deductions (Area in Sq.mt.)		Proposed FAR Area (Sq.mt.)	Total FAR Area (Sq.mt.)	Total Consumed Additional FAR Area (Sq.mt.)	Trmt (No.)
			Resi.	Other				
A (KK)	1	431.03	7.84	423.19	423.19	423.19	423.19	01
Grand Total :	1	431.03	7.84	423.19	423.19	423.19	423.19	01

LTP NAME AND SIGNATURE	STRUCTURAL ENG'S NAME AND SIGNATURE	BUILDER NAME AND SIGNATURE	DIGITAL SIGNATURE
ASHOK KUMAR DMC/ENG/0011/2017			

Proposal Basic Information	
Proposal File No.	DMC/BP/0112/W23/2022
Owner Name	SRI KAUSHAL KISHOR SINGH
Khata No	OLD 41, NEW 199
Plot No	OLD 1942, NEW 2550/4971
Village Name	Kolakusma
Use	Residential
SubUse	Bungalow/ Dwelling / Non Apartment

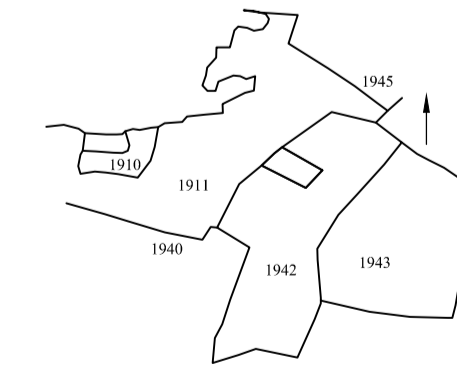
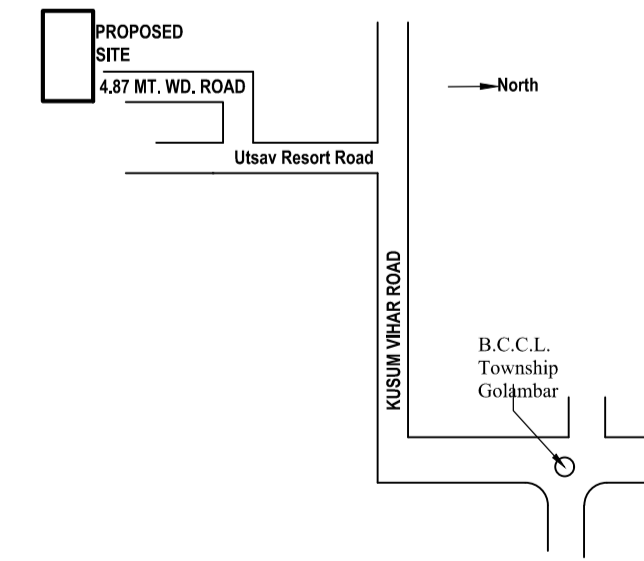
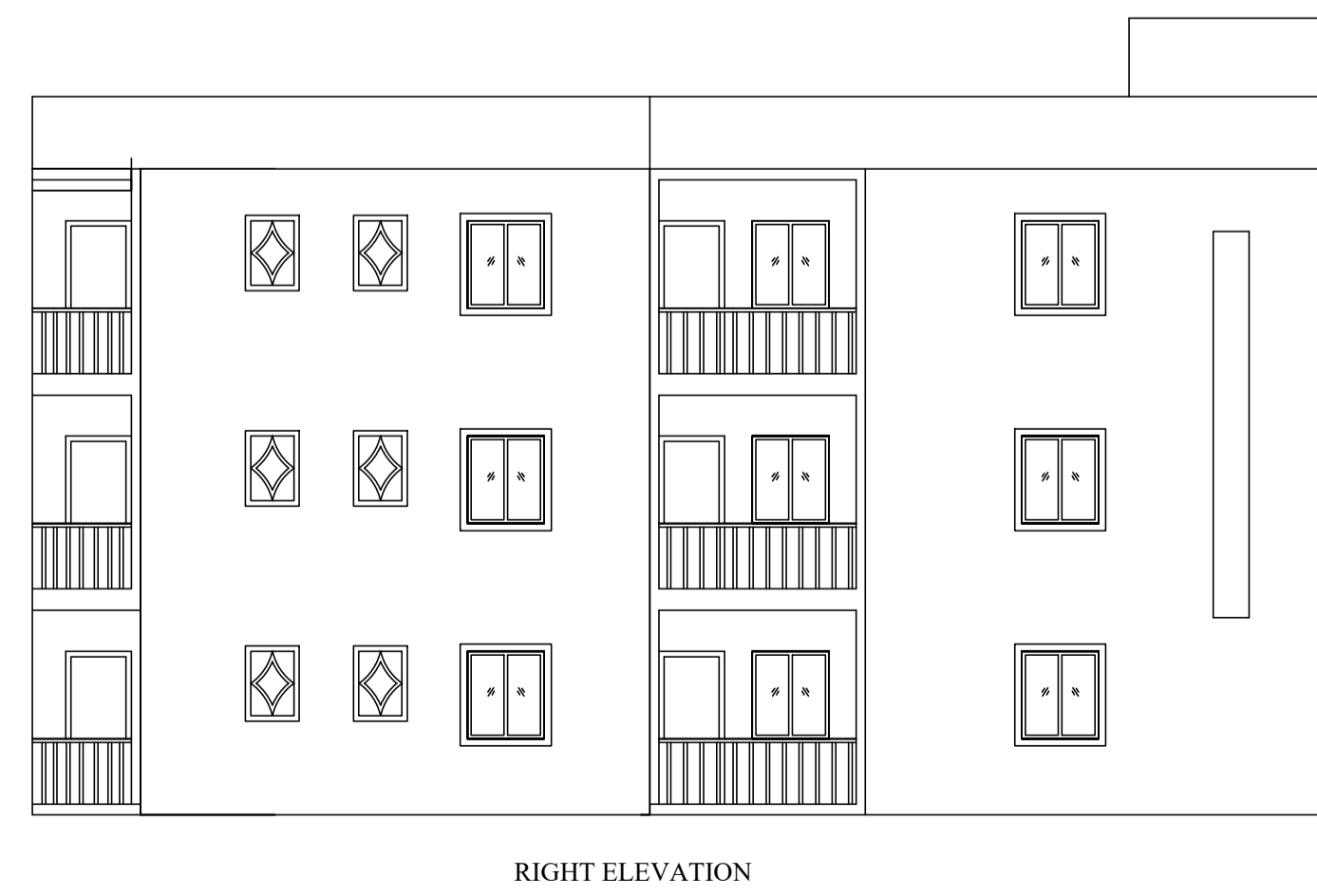
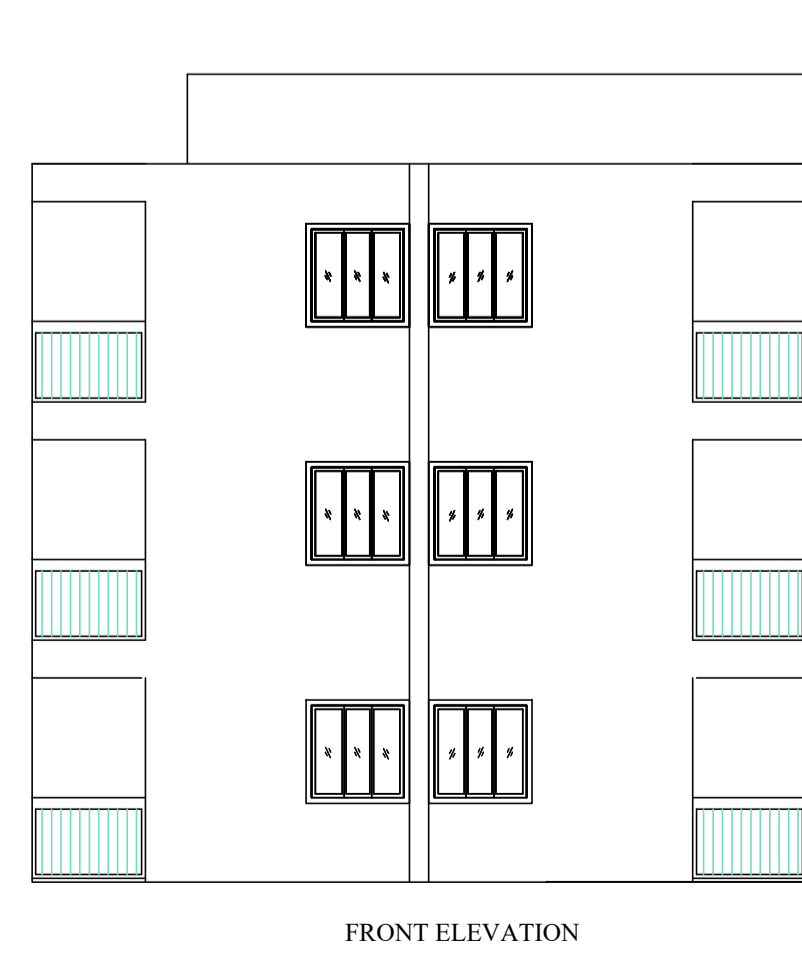
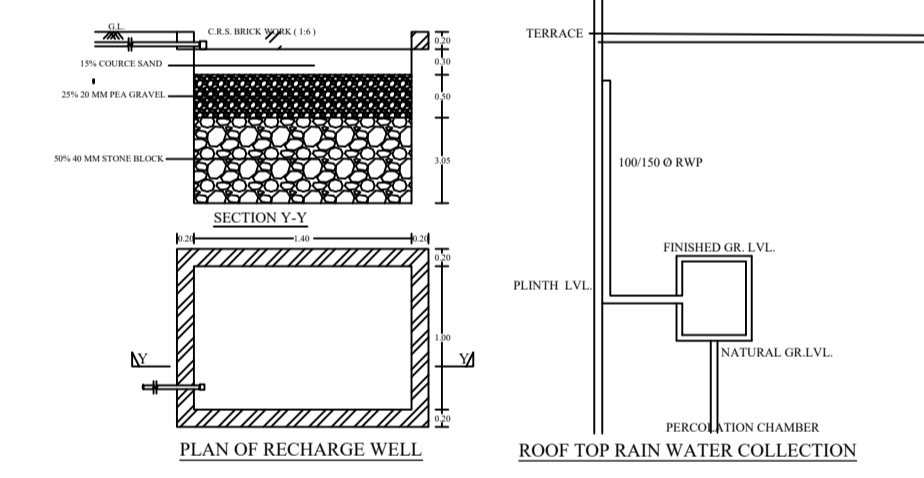
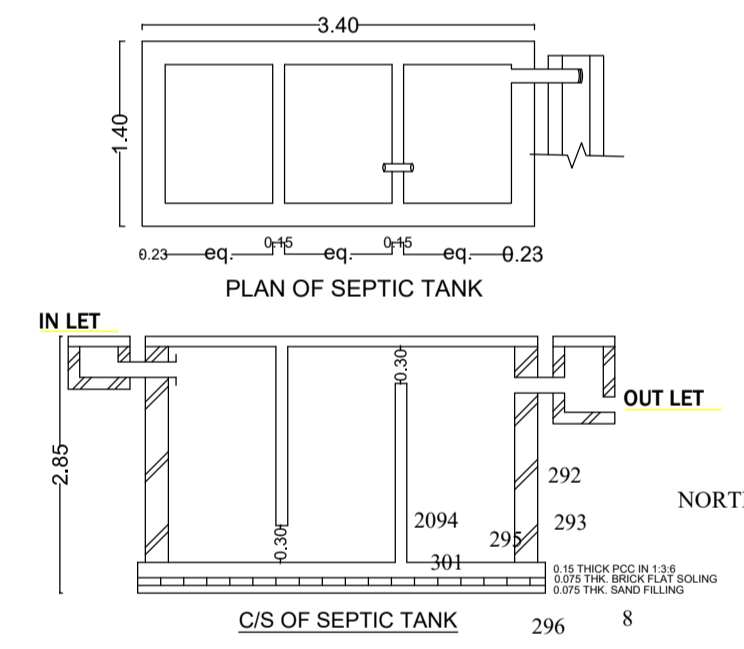
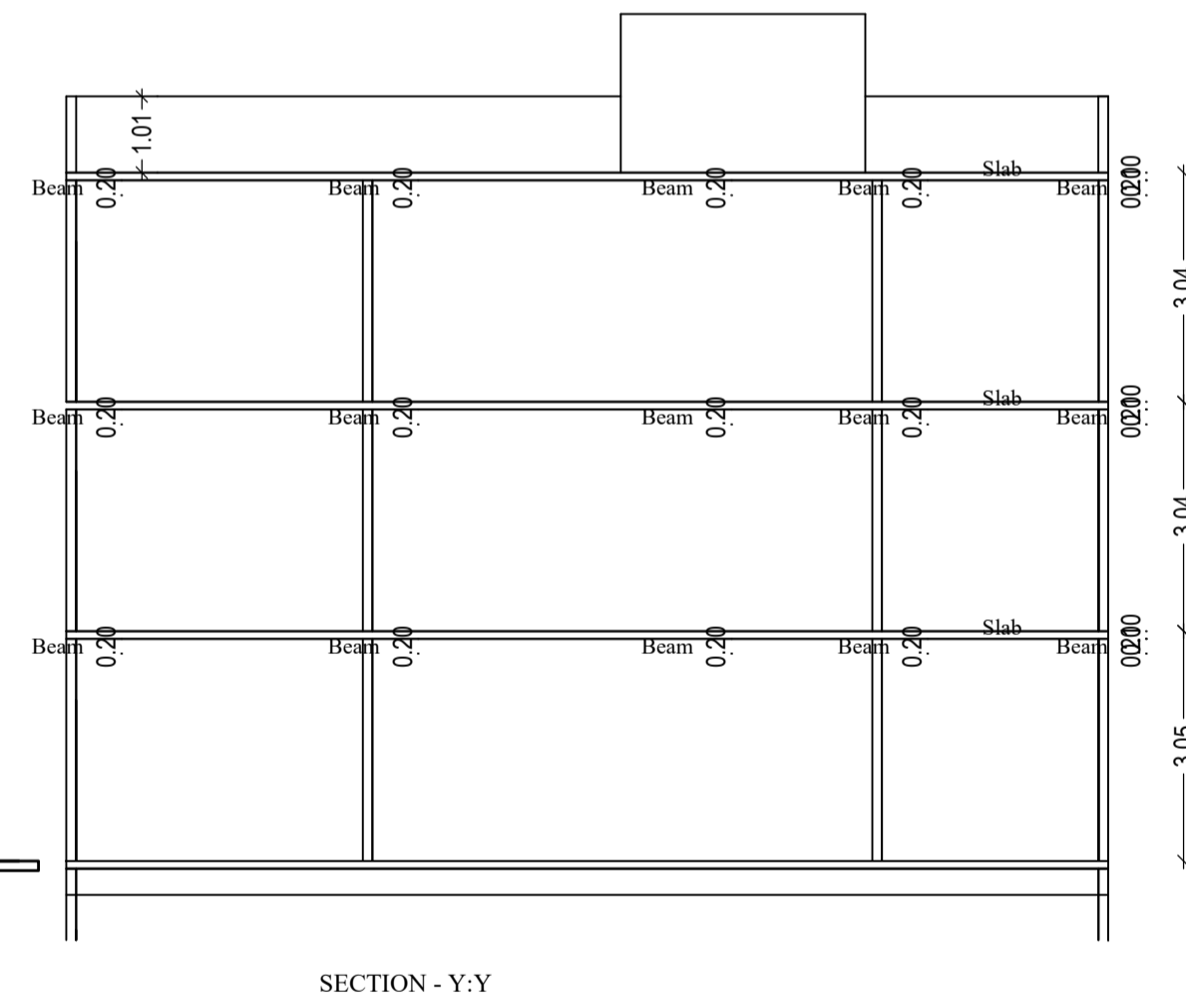
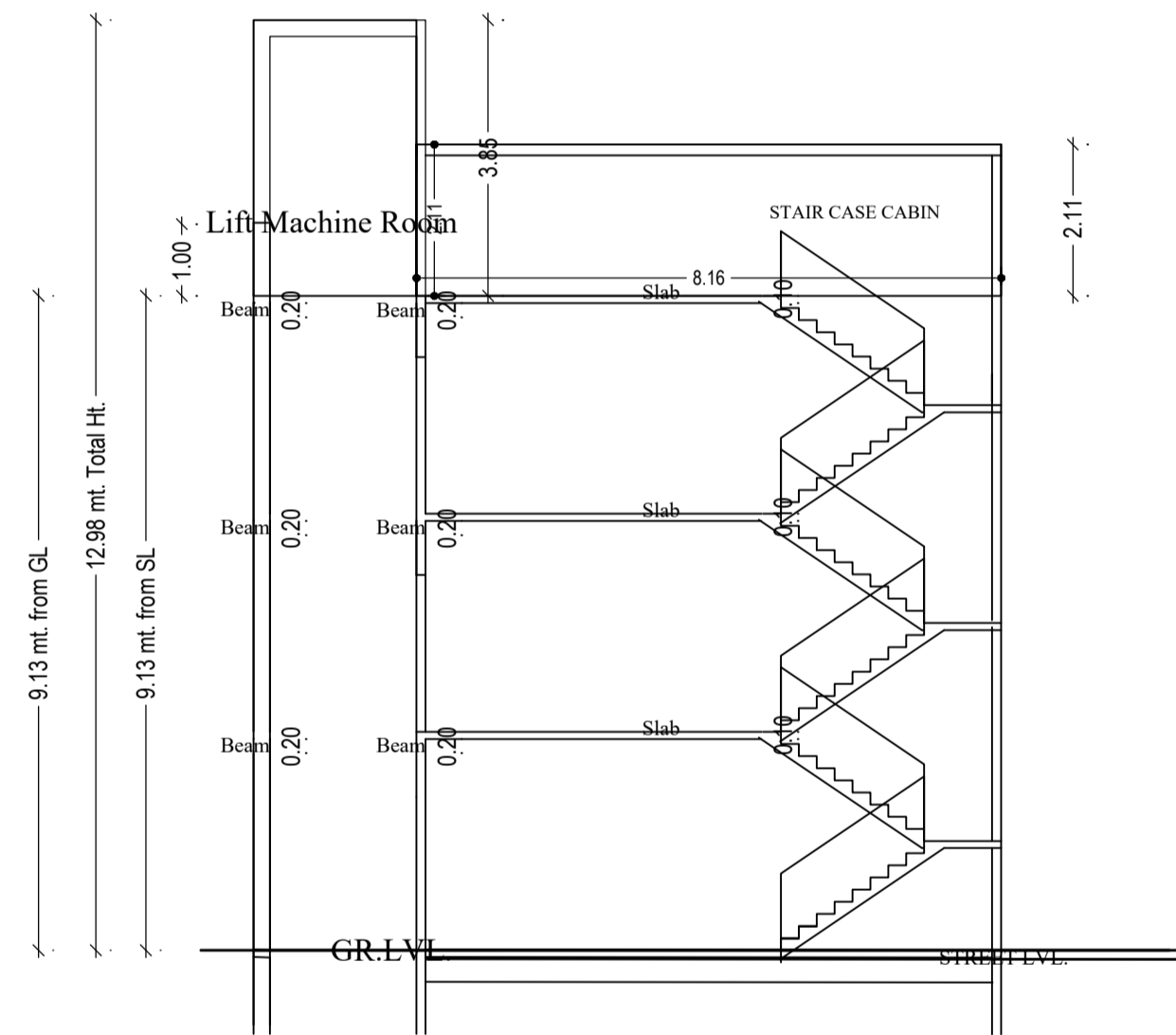
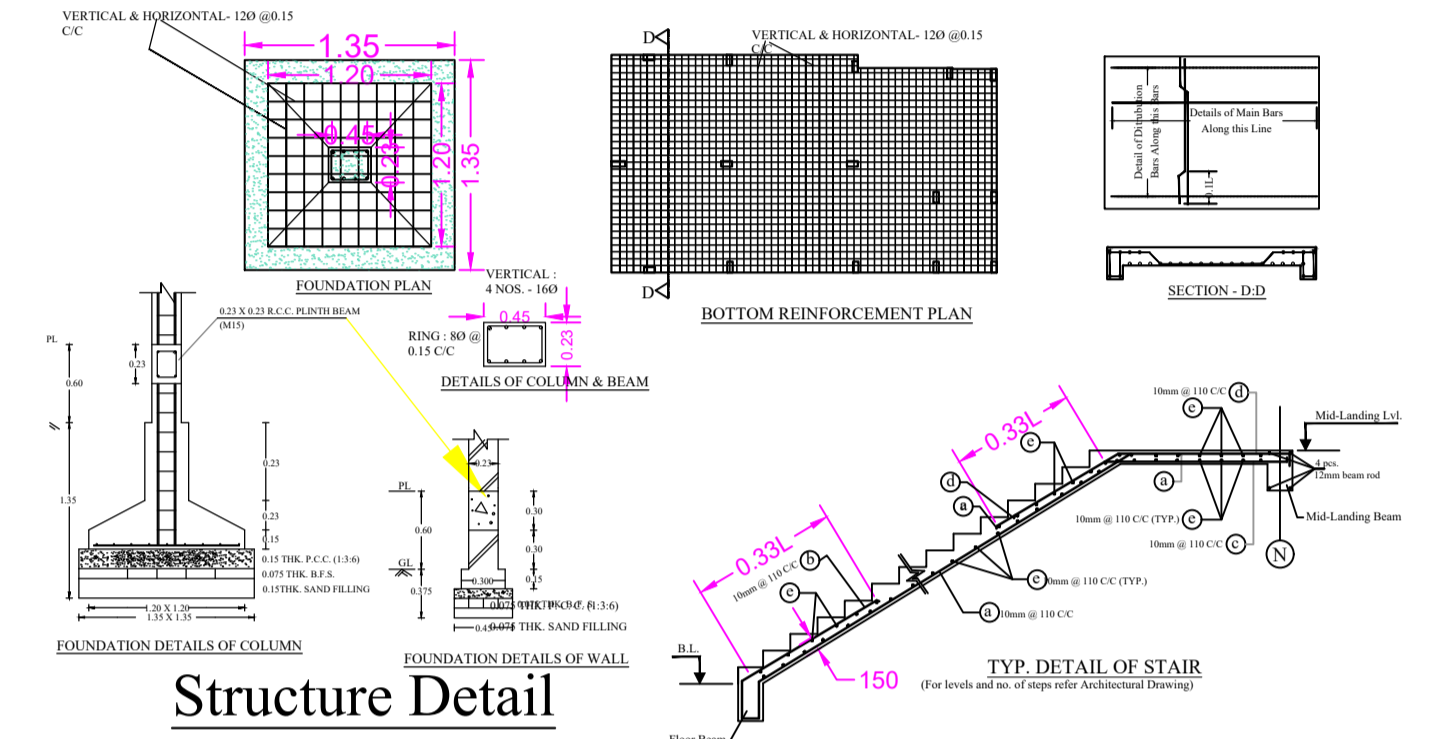
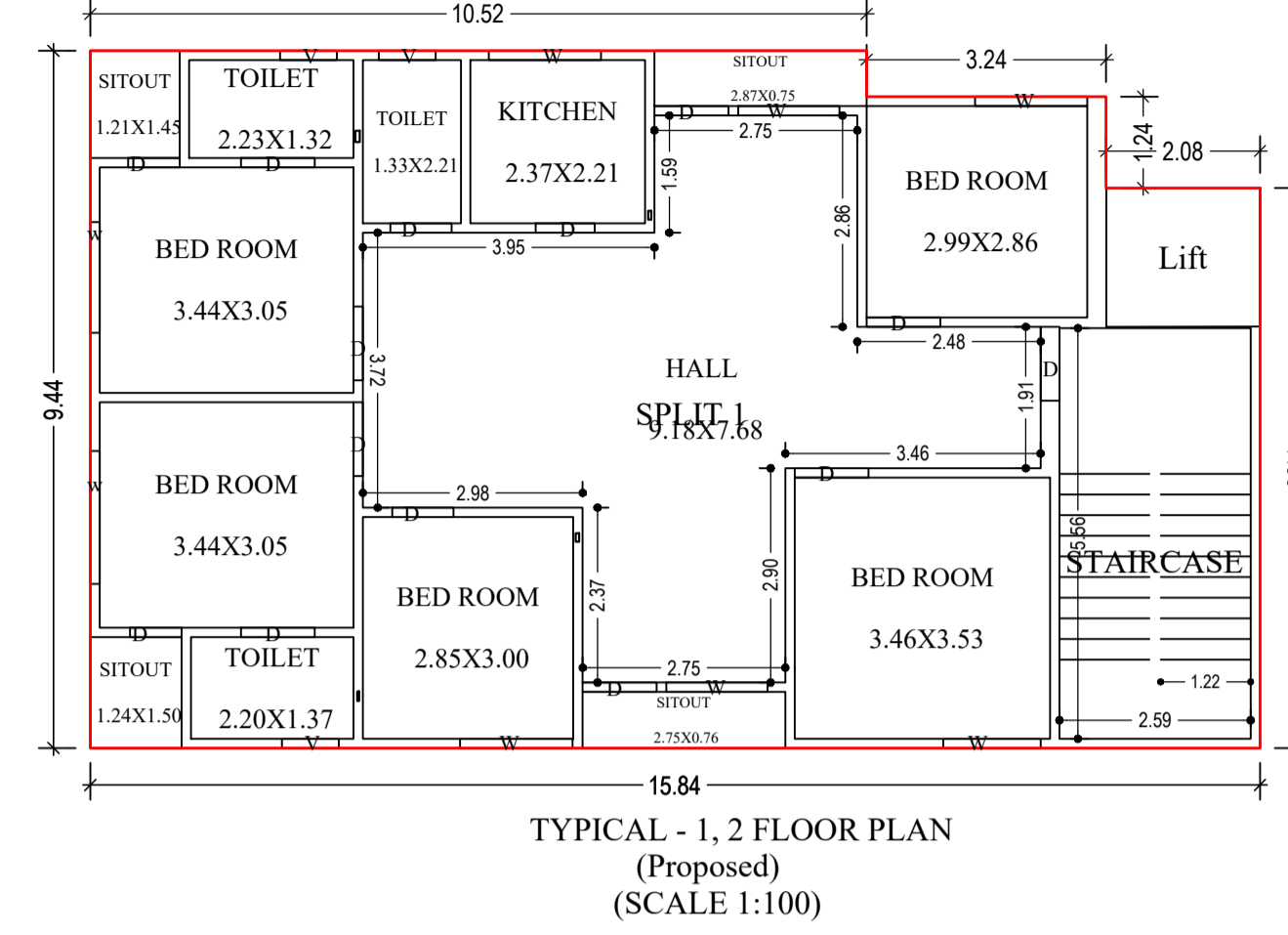
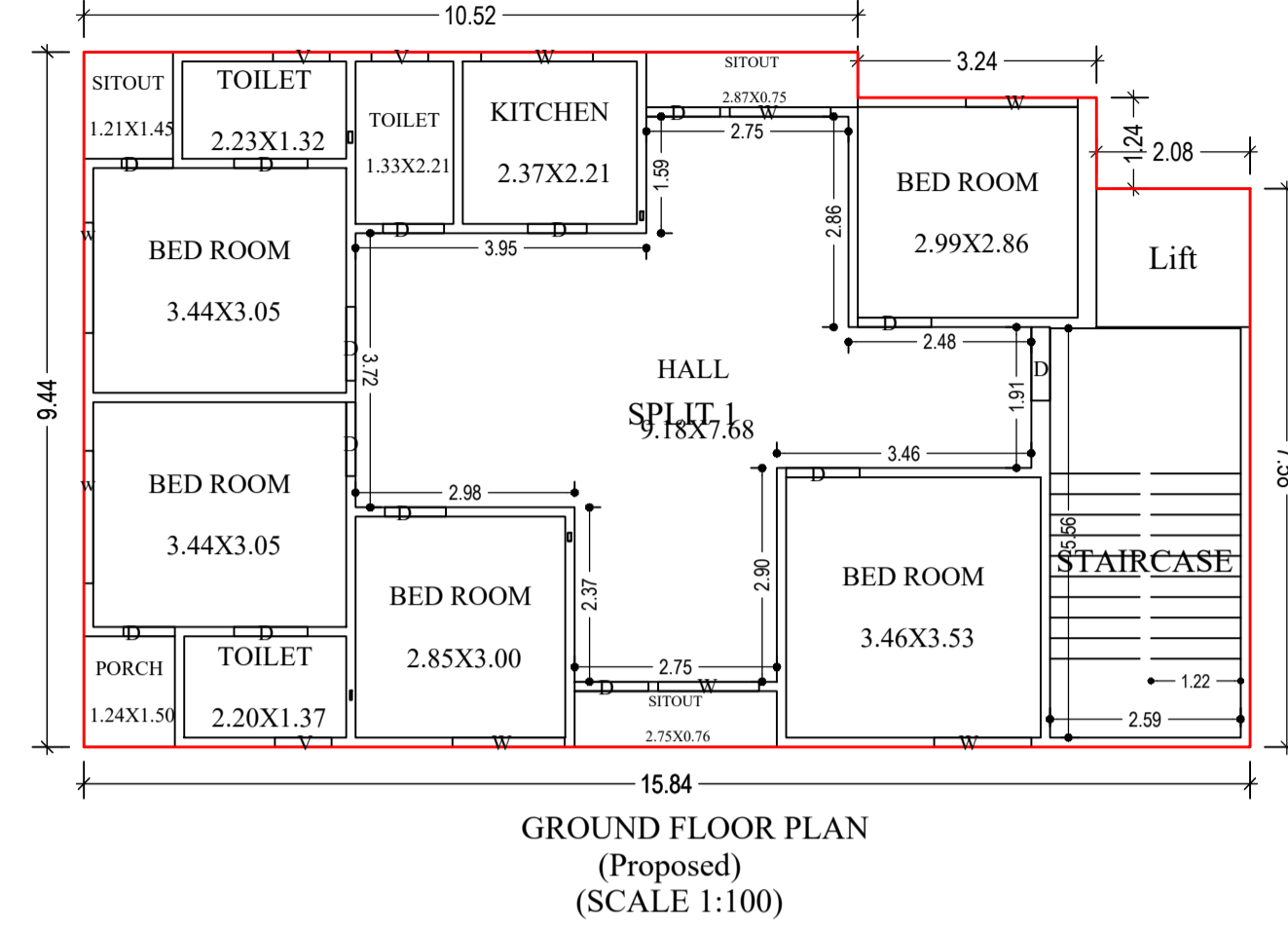
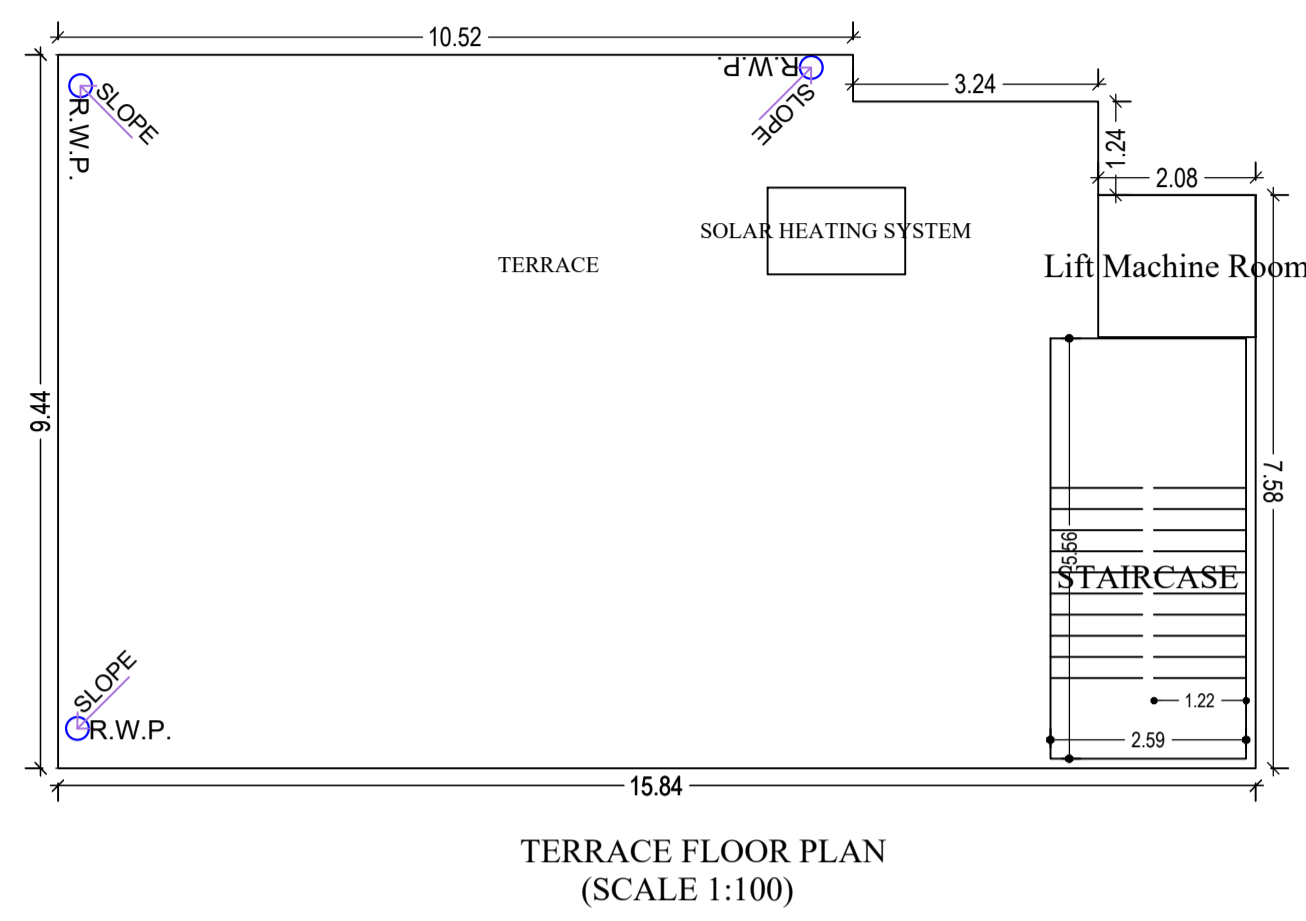

LTP NAME AND SIGNATURE	STRUCTURAL ENG'S NAME AND SIGNATURE	BUILDER NAME AND SIGNATURE	DIGITAL SIGNATURE
ASHOK KUMAR DMC/ENG/0011/2017			