

RADHESYAM MISRA

PART OF THIS PLOT 726

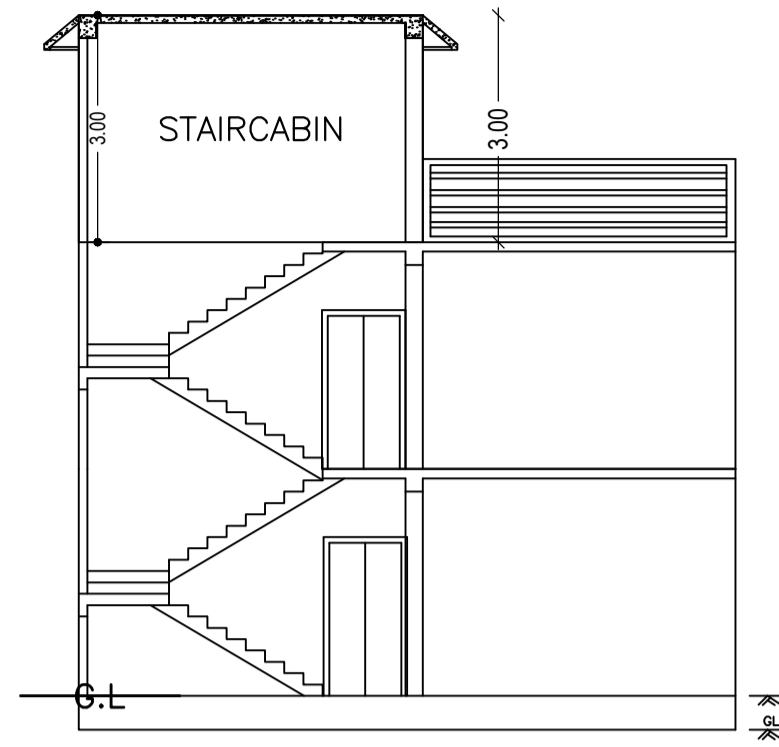

SECTION AT X-X

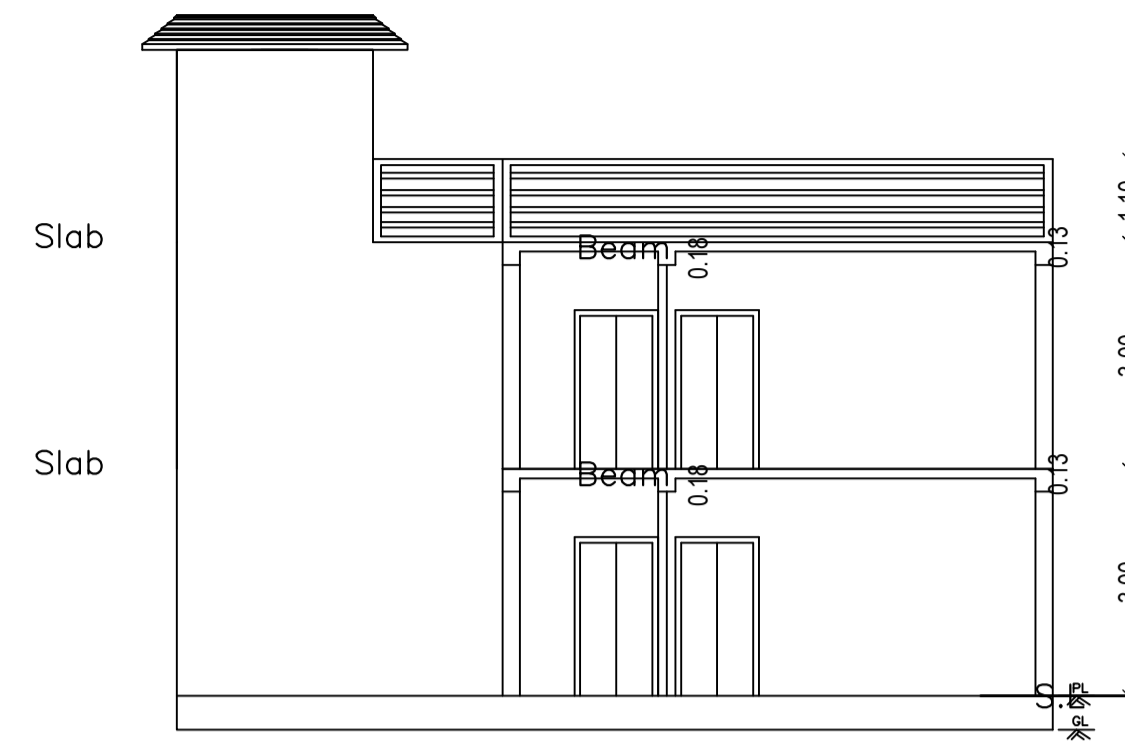

SECTION AT Y-Y

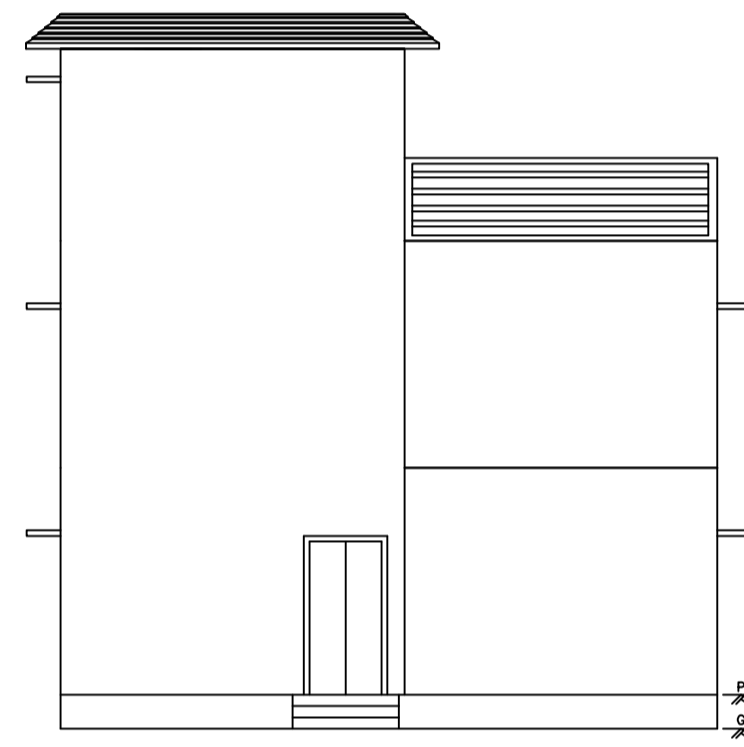

FRONT ELEVATION

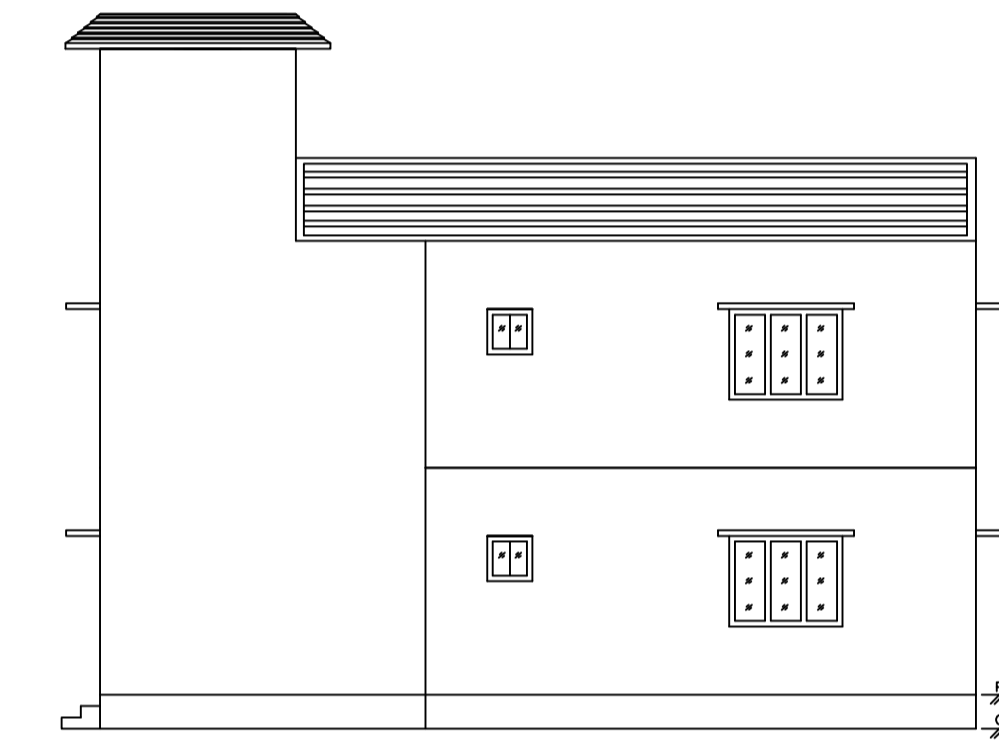

RIGHT SIDE ELEVATION

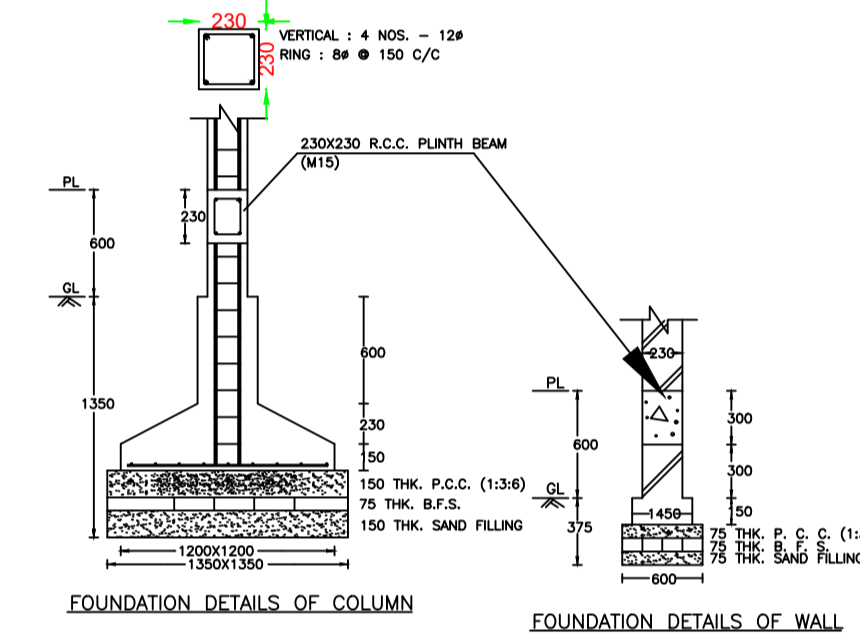

FOUNDATION DETAILS OF COLUMN

FOUNDATION DETAILS OF WALL

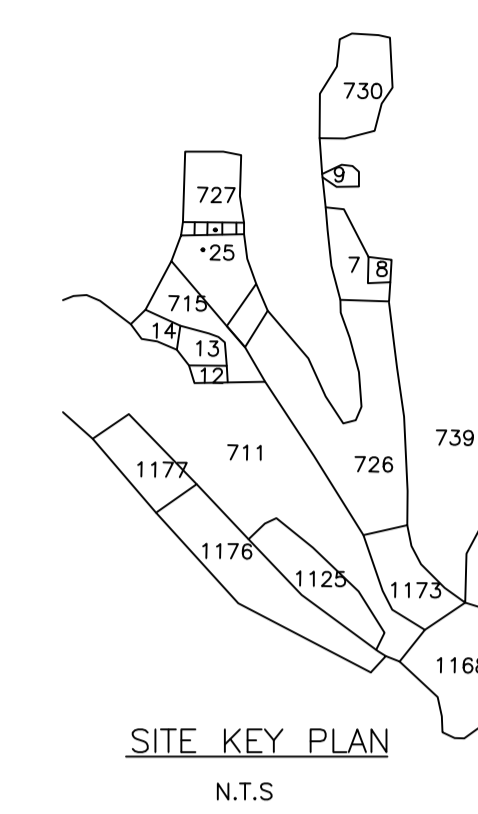

SITE KEY PLAN  
N.T.S

AREA STATEMENT DHANBAD MUNICIPAL CORPORATION		VERSION NO.: 1.0.62 VERSION DATE: 16/10/2020
PROJECT DETAIL:		
Region : JHARKHAND URBAN LOCAL BODIES	Plot Use: Residential	
District: DHANBAD	Plot SubUse: Bungalow/ Dwelling / Non Apartment	
Authority: DHANBAD MUNICIPAL CORPORATION	PlotNearby/ReligiousStructure: NA	
Inward No: DMC/BP/D156/W22/2022	Plot/SubPlot No: 726 (O) 774 (N)	
Application Type: General Proposal	North: Road Width - 4.87	
Project Type: Building Permission	South: Plot No. - PLOT NO. 715	
Nature of Development: New	East: Plot No. - RADHESYAM MISRA	
Location of Development Area: Old Area	West: Plot No. - PART OF THIS PLOT 726	
AREA DETAILS:		
AREA OF PLOT (Minimum)	(A)	SQ.MT. 199.98
Deduction for NetPlot Area		
Road Widening Area		6.73
Total		6.73
NET AREA OF PLOT (Gross Plot Area - Deduction from Gross Plot area)	(A-Deductions)	193.25
Deduction for Balance Plot Area (from Gross Plot Area)		
Road Widening Area		6.73
Common Plot		16.64
Total		23.37
BALANCE AREA OF PLOT (Net Plot Area - Recreational/Amenity space)	(A-Deductions)	176.61
PLOT AREA FOR COVERAGE (Net Plot Area)	(A-Deductions)	193.25
Plot Area for FAR (Net Plot Area + Road Widening Area)	(A-Deductions)	193.25
COVERAGE CHECK		
Permissible Coverage Area ( 70.00 % )		135.27
Proposed Coverage Area ( 40.18 % )		77.64
Total Prop. Coverage Area ( 40.18 % )		77.64
Balance coverage area ( 29.82 % )		57.63
FAR CHECK		
Perm. FAR Area ( 1.80 )		347.85
Total Perm. FAR area		347.85
Residential FAR		155.27
Proposed FAR Area		155.27
Total Proposed FAR Area		155.27
Consumed FAR (Factor)		0.80
Balance FAR Area		192.58
BUILT UP AREA CHECK		
Total Proposed BuiltUp Area		155.28
ARCHITECT (Regd)		JITENDAR KUMAR
ENGINEER (Regd)		
SUPERVISOR (Regd)		
OWNER (Regd)		Sri. MUKTESHWAR TIWARI
DEVELOPMENT AUTHORITY		LOCAL BODY

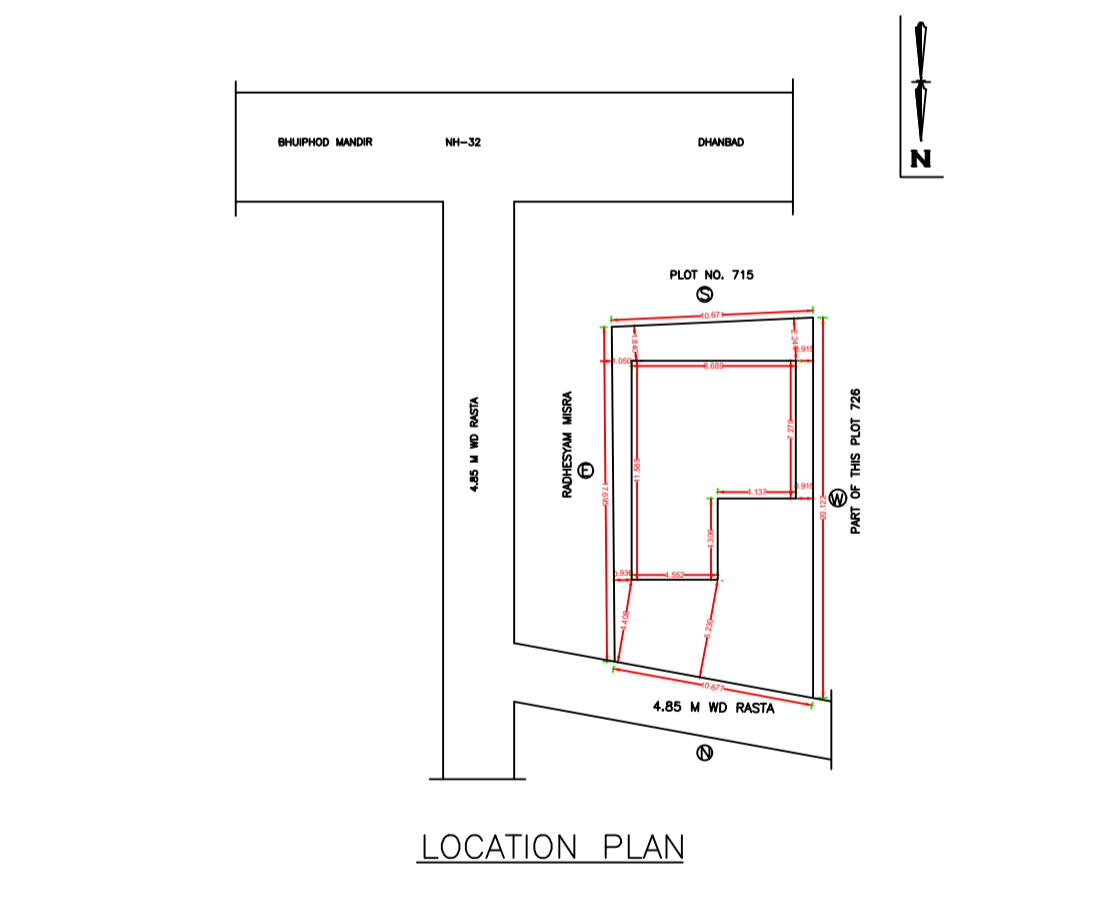

LOCATION PLAN

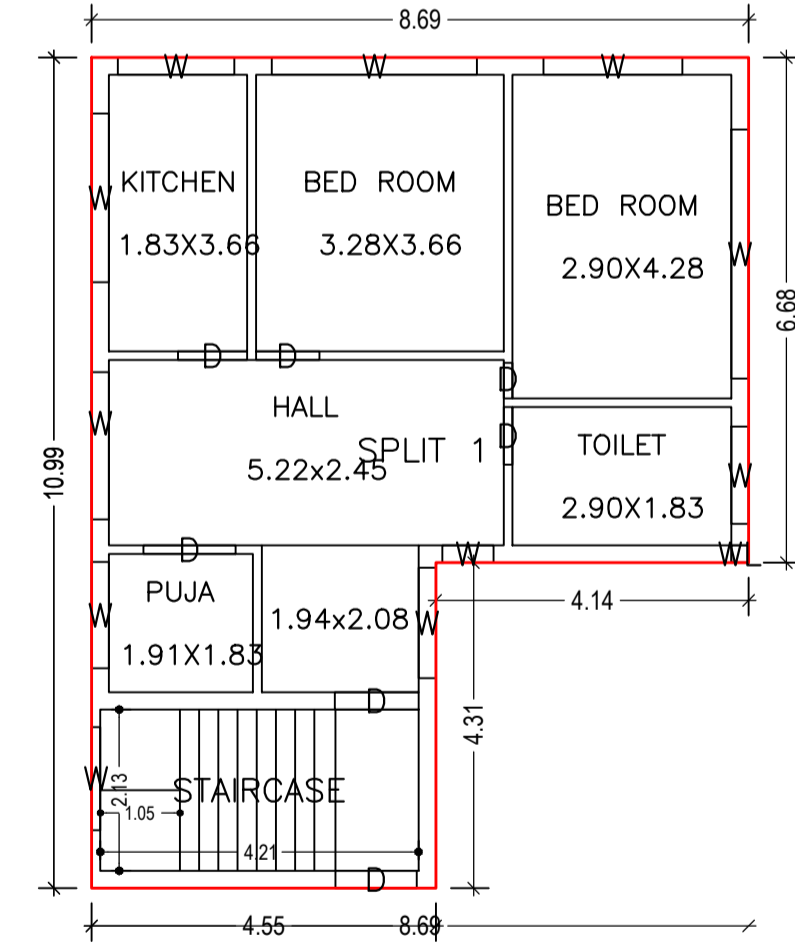

GROUND FLOOR PLAN (Proposed)

(SCALE 1:100)

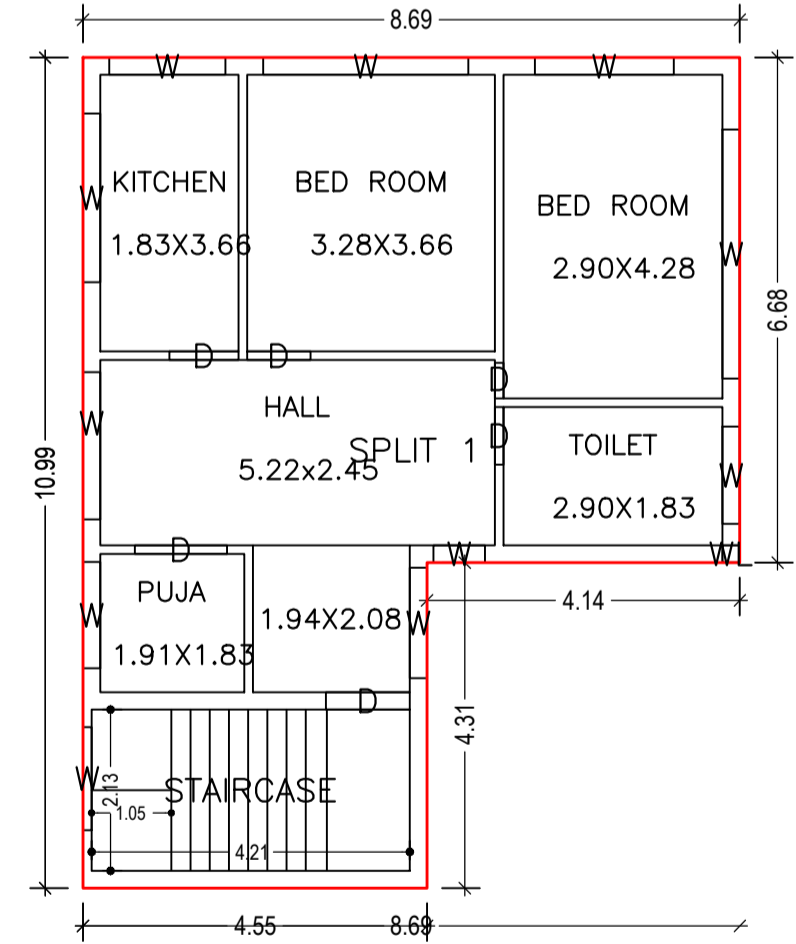

FIRST FLOOR PLAN (Proposed)

(SCALE 1:100)

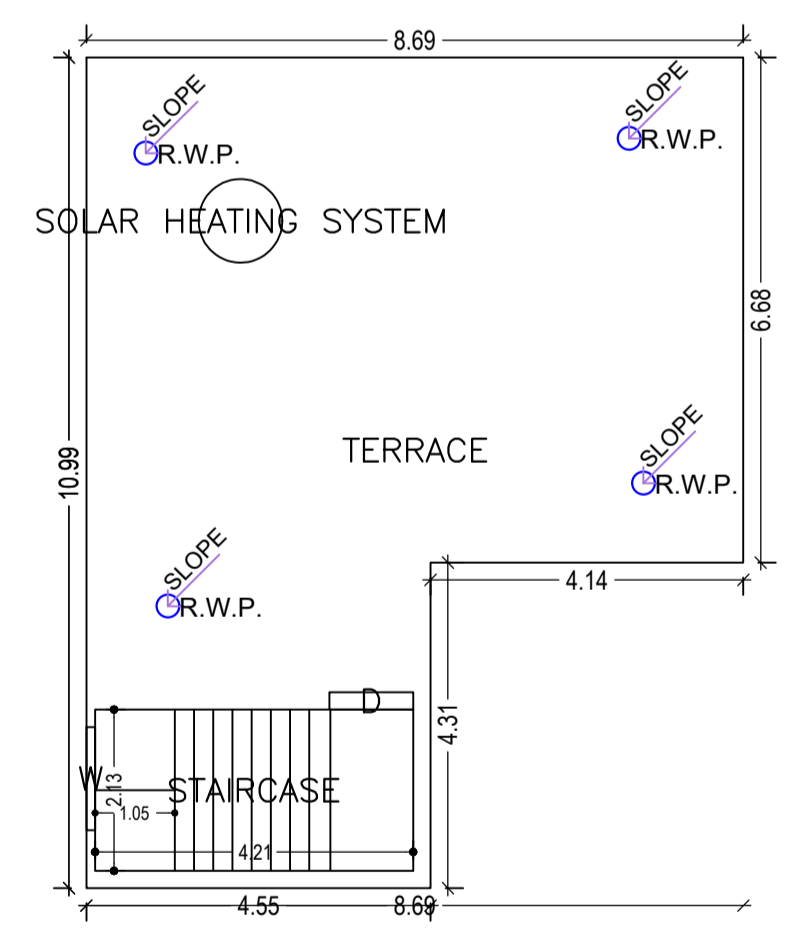

TERRACE FLOOR PLAN (Proposed)

(SCALE 1:100)

SCHEDULE OF DOOR:

BUILDING NAME	NAME	LENGTH	HEIGHT	NOS
A (B)	D	0.47	2.10	02
A (B)	D	0.76	2.10	02
A (B)	D	0.84	2.10	02
A (B)	D	0.91	2.10	02
A (B)	D	1.11	2.10	02
A (B)	D	1.22	2.10	02

SCHEDULE OF WINDOW/VENTILATION:

BUILDING NAME	NAME	LENGTH	HEIGHT	NOS
A (B)	W	0.68	1.20	02
A (B)	W	1.29	1.20	02
A (B)	W	1.36	1.20	03
A (B)	W	1.41	1.20	02
A (B)	W	1.46	1.20	02
A (B)	W	1.54	1.20	02
A (B)	W	1.84	1.20	02
A (B)	W	1.95	1.20	02
A (B)	W	2.23	1.20	02
A (B)	W	2.71	1.20	02
A (B)	W	3.30	1.20	02

Building :A (B)

Floor Name	Total Built Up Area (Sq.mt.)	Proposed FAR Area (Sq.mt.) Resi.	Total FAR Area (Sq.mt.)	Total Consumed Additional FAR Area (Sq.mt.)	Tnmt (No.)
Ground Floor	77.64	77.64	77.64	77.64	01
First Floor	77.64	77.64	77.64	77.64	00
Terrace Floor	0.00	0.00	0.00	0.00	00
Total:	155.28	155.28	155.28	155.28	01
Total Number of Same Buildings	1				
Total:	155.28	155.28	155.28	155.28	01

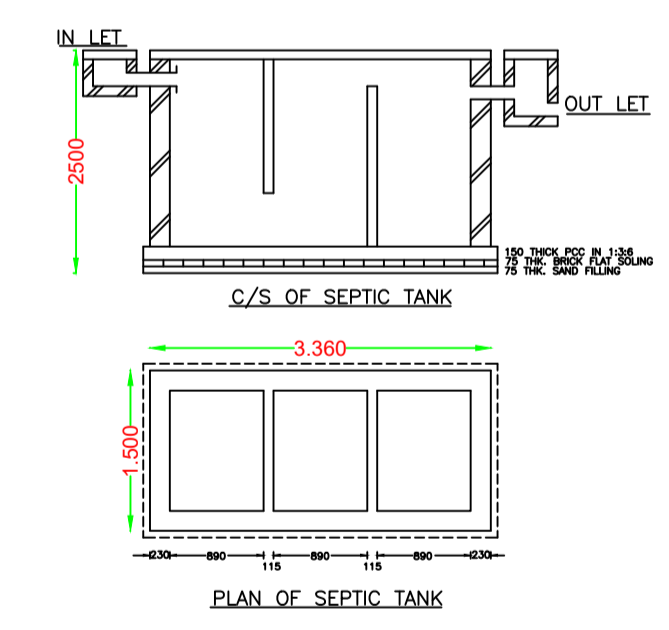

PLAN OF SEPTIC TANK

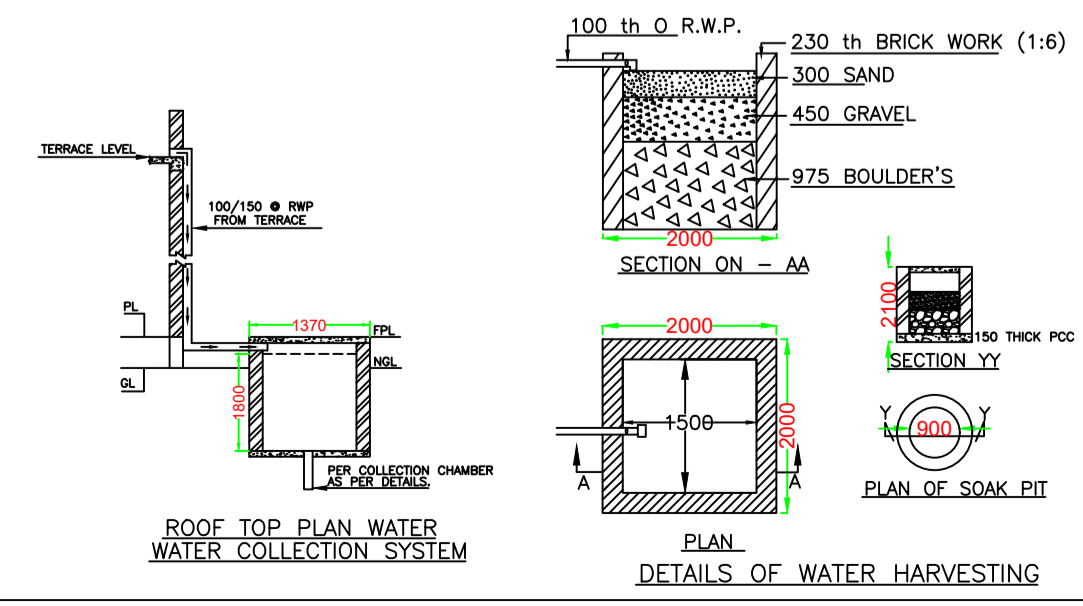

ROOF TOP PLAN WATER COLLECTION SYSTEM

DETAILS OF WATER HARVESTING

COLOR INDEX	
PLOT BOUNDARY	Black
ABUTTING ROAD	Green
PROPOSED CONSTRUCTION	Red
COMMON PLOT	Yellow
ROAD WIDENING AREA	Blue
EXISTING (To be retained)	Light Blue
EXISTING (To be demolished)	Dark Blue

Buildingwise Floor FAR Details				
Floor Name	Building Name A (B)		Total	
	Proposed Built Up Area (Sq.mt.)	Proposed FAR Area (Sq.mt.)	Total Proposed Built Up Area (Sq.mt.)	Total FAR Area (Sq.mt.)
Ground Floor	77.64	77.64	77.64	77.64
First Floor	77.64	77.64	77.64	77.64
Terrace Floor	0.00	0.00	0.00	0.00
Total	155.28	155.28	155.28	155.28

Building USE/SUBUSE Details			
Building Name A (B)	Building Use Residential	Building SubUse Residential Bldg/Apartment	Building Structure Non-Highrise

FAR & Tenement Details (Table 4c-1)						
Building	No. of Same Bldg	Total Built Up Area (Sq.mt.)	Proposed FAR Area (Sq.mt.) Resi.	Total FAR Area (Sq.mt.)	Total Consumed Additional FAR Area (Sq.mt.)	Tnmt (No.)
A (B)	1	155.28	155.28	155.28	155.28	01
Grand Total:	1	155.28	155.28	155.28	155.28	01

UnitBUA Table for Building :A (B)						
FLOOR	Name	UnitBUA Type	UnitBUA Area	Carpet Area	No. of Rooms	No. of Tenement
GROUND FLOOR PLAN	SPLIT 1	FLAT	155.27	155.17	6	1
FIRST FLOOR PLAN	SPLIT 1	FLAT	0.00	0.00	6	0
Total:	-	-	155.27	155.17	12	1

LTP NAME AND SIGNATURE	STRUCTURAL ENG'S NAME AND SIGNATURE	BUILDER NAME AND SIGNATURE	DIGITAL SIGNATURE
JITENDAR KUMAR DMC/DFTM/006/2018			