

Project Title :RAMSATTI DEVI

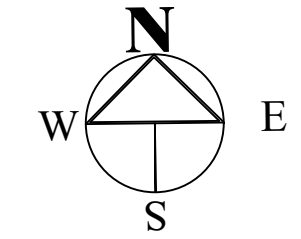
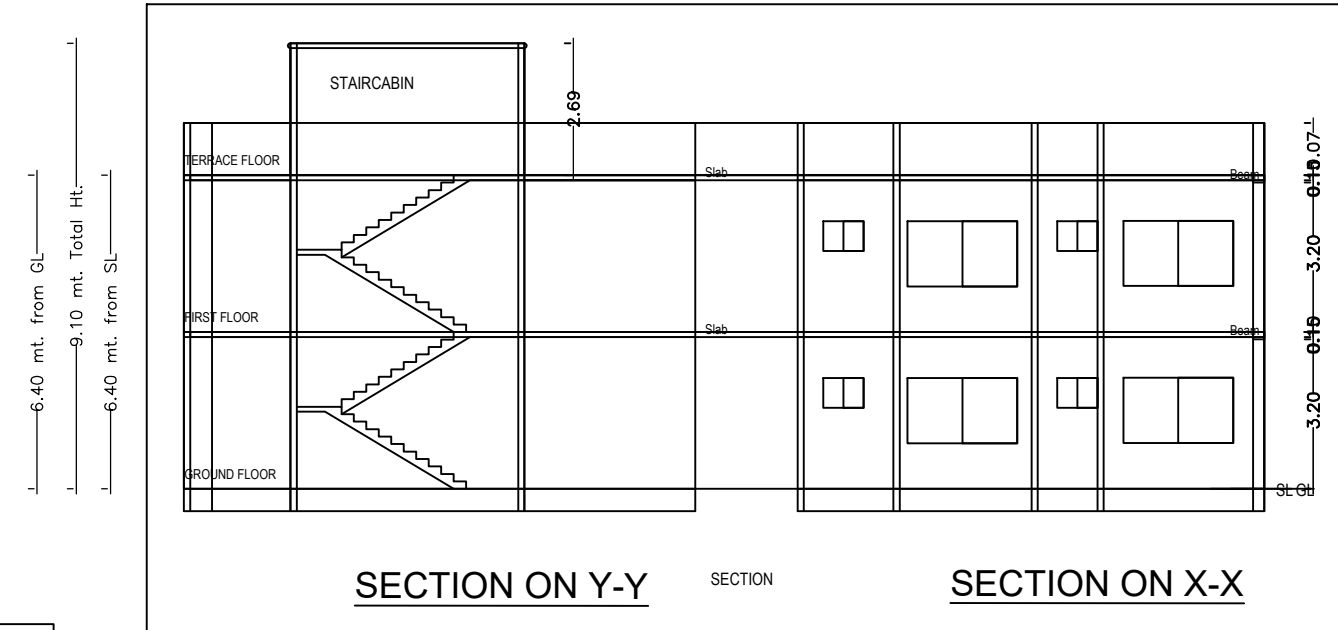
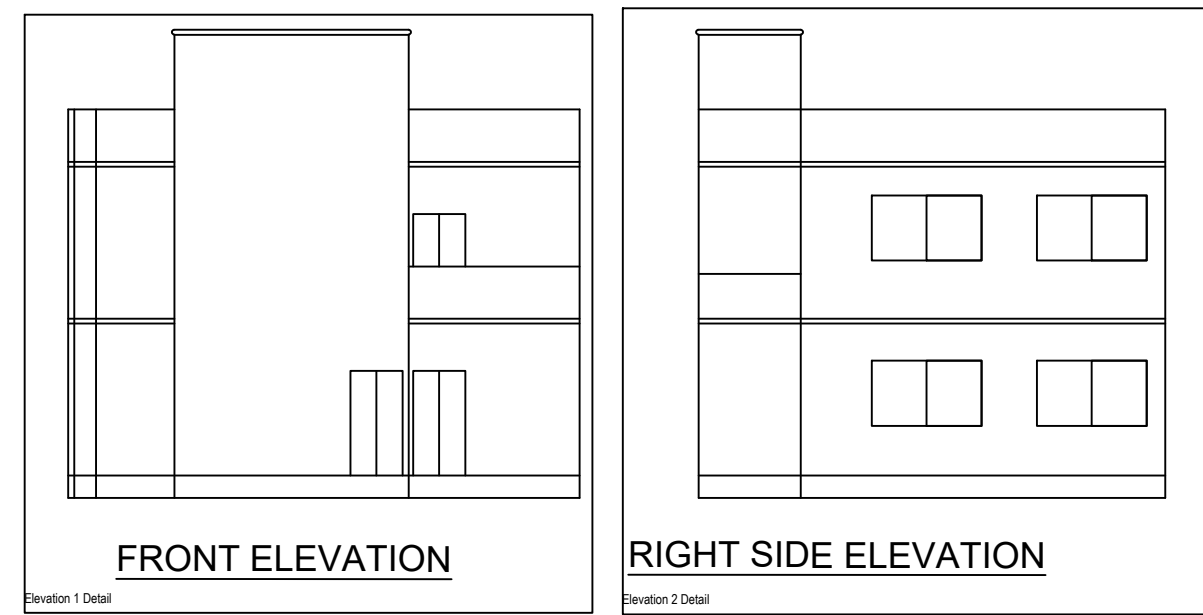

BRIEF SPACEFICATION

FOUNDATION----- CEMENT CONCRETE (1:1.5:3)
 BRICK WORK IN FOUNDATION & SUPERSTRUCTURE
 FIRST CLASS BRICK WORK IN CEMENT MORTAR (1:1:6)
 D.P.C.-----25 D.P.C. IN CEMENT CONCRETE (1:2:4)
 FLOOR-----25 I.P.S. OVER 75 P.C.C.
 ROOF-----100 THK. R.C.C. ROOF (1:1.5:3)
 LINTEL-----150 THK. R.C.C. LINTEL (1:1.5:3)
 STAIRS----- RISE-- 150, TREAD-- 250

DETAILS OF AREA

TOTAL AREA (AS PER DEED)	158.50 SQM
GROUND FLOOR AREA	96.49 SQM.
FIRST FLOOR AREA	96.49 SQM.
TOTAL COVERED AREA	192.98 SQM
% PLINTH AREA	60.87 %
FAR	1.28

SCHEDULE

D = 1.200X2.100	W = 1.800X1.200
D1 = 1.050X2.100	W2 = 0.900X1.200
D2 = 0.900X2.100	V = 0.600X0.600

TITLE OF DRAWING

PLAN OF PROPOSED RESIDENTIAL BUILDING SMT RAMSATTI DEVI W/O SRI RAVINDRA SINGH UNDER MOUZA KOLAKUSHMA , 12 ; HAVING PLOT NO. 2153(NEW:2611) , KHATA NO. : 69(NEW: 258) IN THE DIST. OF DHANBAD

 SIGNATURE OF OWNER

 SIGNATURE OF ENGINEER

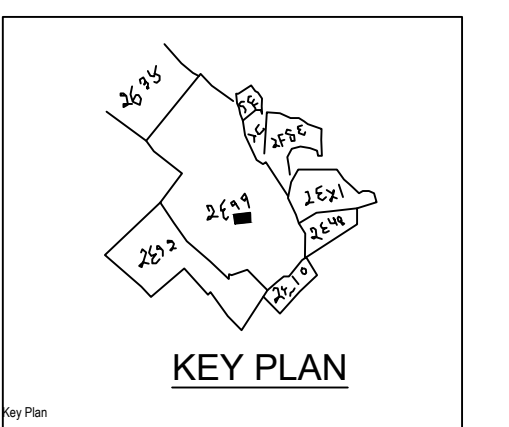
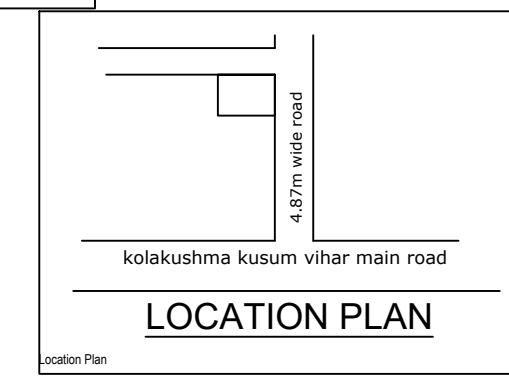
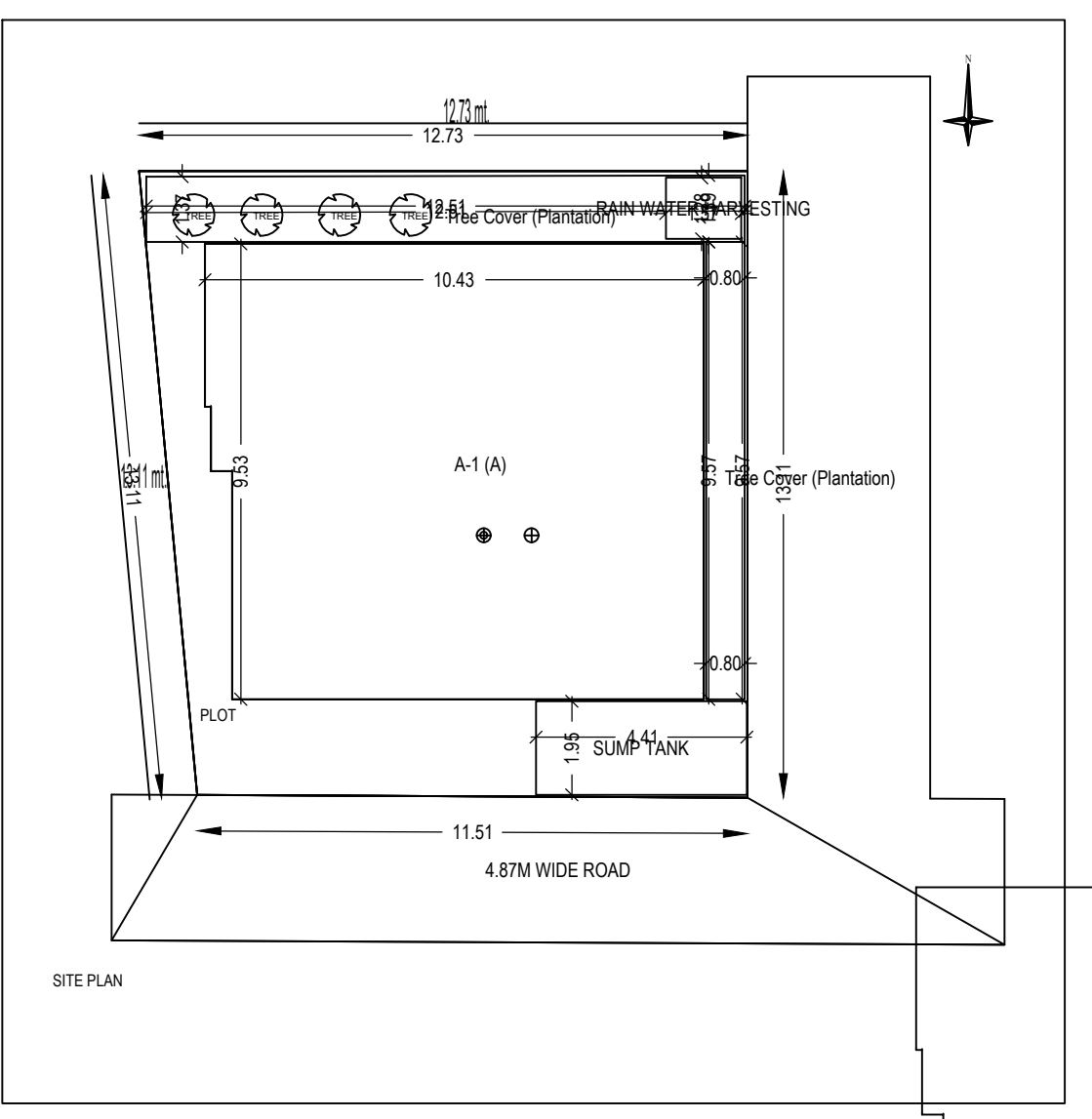
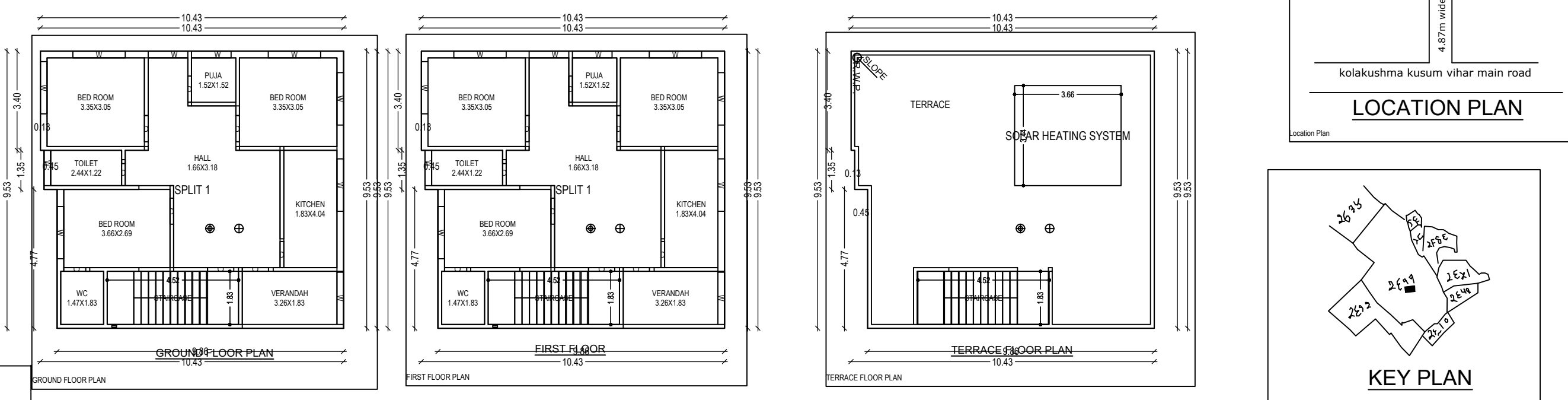
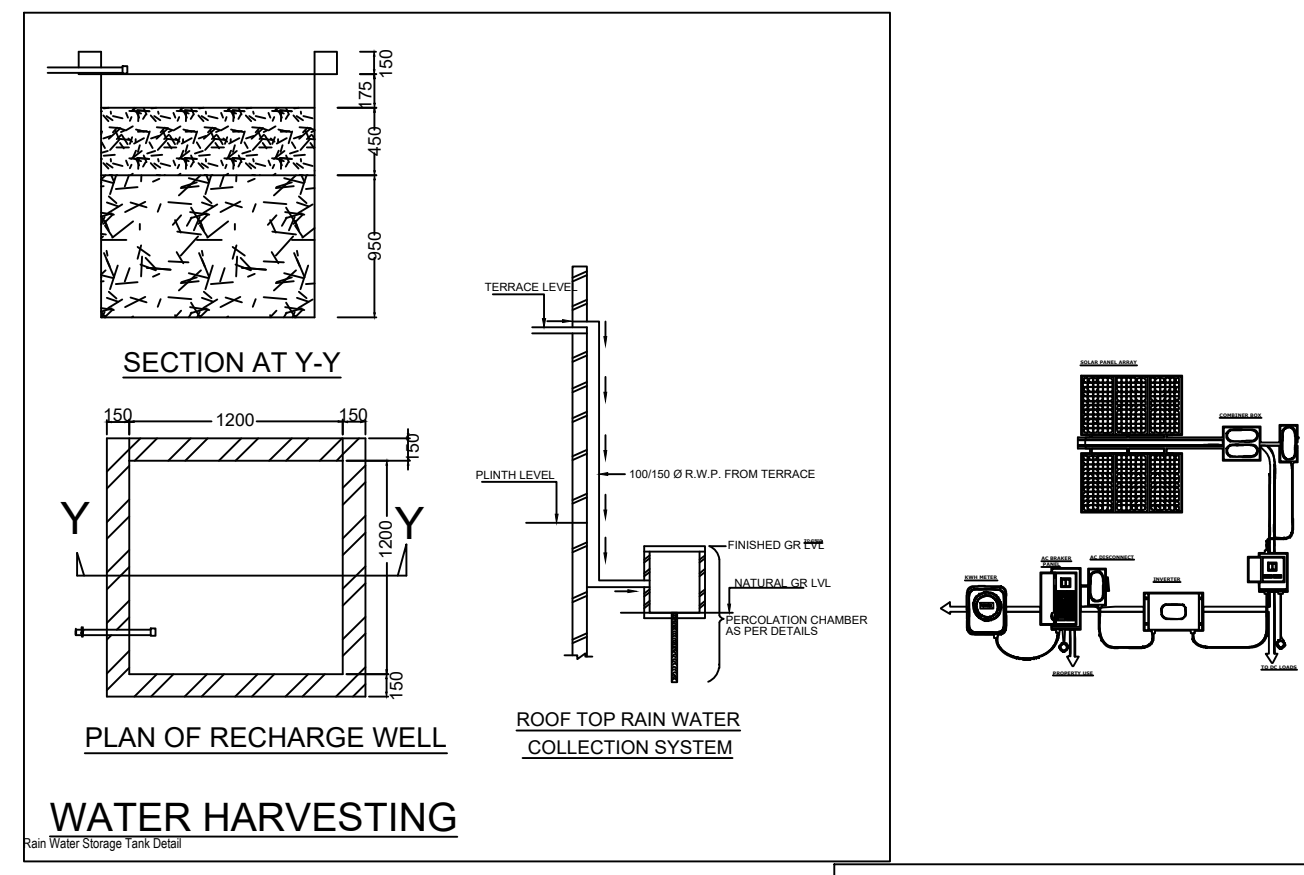
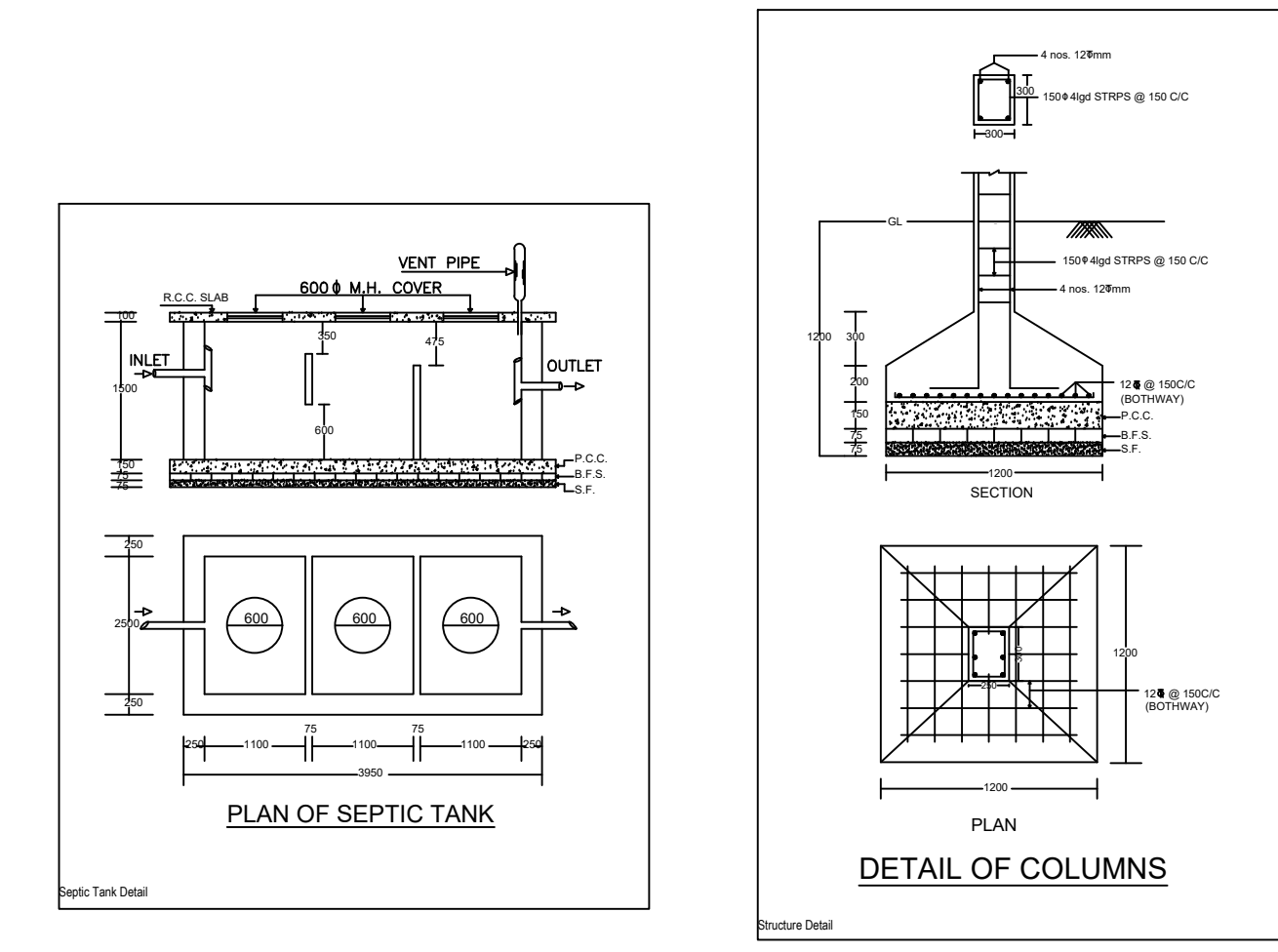

Building 'A' (A)

Floor Name	Total Built Up Area (Sq.Mt.)	Proposed FAR Area (Sq.Mt.)	Total FAR Area (Sq.Mt.)	Trms (No.)
Ground Floor	96.49	96.49	96.49	01
First Floor	96.49	96.49	96.49	01
Terrace Floor	0.00	0.00	0.00	01
Total	192.98	192.98	192.98	01

SCHEDULE OF JOINERY:

BUILDING NAME	NAME	LENGTH	HEIGHT	NOS
A(A)	D	2.90	2.10	18
	10W	-	-	18

SCHEDULE OF JOINERY:

BUILDING NAME	NAME	LENGTH	HEIGHT	NOS
A(A)	W	1.22	1.20	02
A(A)	W	1.38	1.20	04
A(A)	W	1.80	1.20	14
Total	-	-	-	20

UnBUA Table for Building 'A' (A)

FLOOR	Name	UnBUA Type	UnBUA Area	Corpl Area	No. of Rooms	No. of Tenement
GROUND FLOOR PLAN	SPLIT 1	PLAT	192.98	192.98	18	1
Total	-	-	192.98	192.98	18	1

AREA STATEMENT: DHANBAD MUNICIPAL CORPORATION	VERSION NO. 1.0.32
PROJECT DETAIL:	VERSION DATE: 16/10/2020
Plot No. : -	Plot Use: Residential
Region: ANURAVINDRAN LOCAL BODIES	Plot Subtype: Single/Family Dwelling / Non-Apartment
DISTRICT: DHANBAD	Land Use Zone: Residential
Application Type: General Proposal	Abutting Road Width: -
Project Type: Building Normation	Plot No.:
Nature of Development: New	Revenue Survey No/Survey No.:
Location: Old Area	Plot No.:
Site Location: 1/8	Plot No.:
Village/Mouza Name: -	Khata No.:
Ward No.:	North.:
Road/Street: -	South.:
	East.:
	West.:

COLOR INDEX

Plot Boundary	---
Abutting Road	---
Proposed Work (Coverage Area)	---
Existing (To be retained)	---
Existing (To be demolished)	---

Color Index

MARGIN DETAIL:

Building / Wing Name	Road Name	Front Margin	Rear Margin	Side Margin

FAR & Tenement Details (Table 4c-1)

		192.98	192.98	01
Grand Total	1	192.98	192.98	01