

Proposal Basic Information

| | |
|-------------------|------------------------------------|
| Proposal File No. | DMC/BP/0186/W29/2022 |
| Owner Name | KHUSHBU SINGH |
| Khata No | OLD-3 NEW-5 |
| Plot No | OLD-766 NEW-556 |
| Village Name | Duhatland |
| Use | Residential |
| SubUse | Bungalow/ Dwelling / Non Apartment |

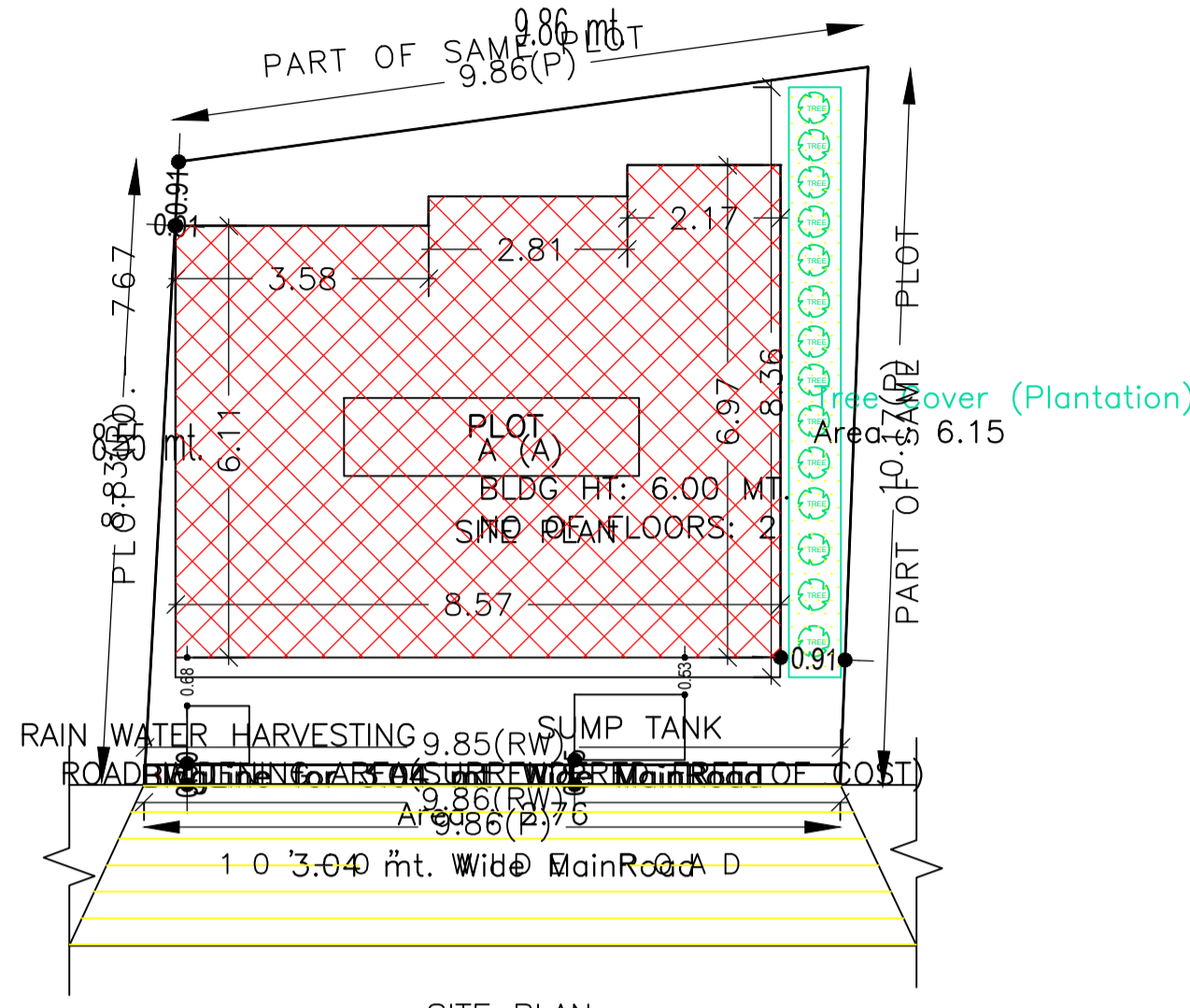

SITE PLAN
SCALE - 1:100

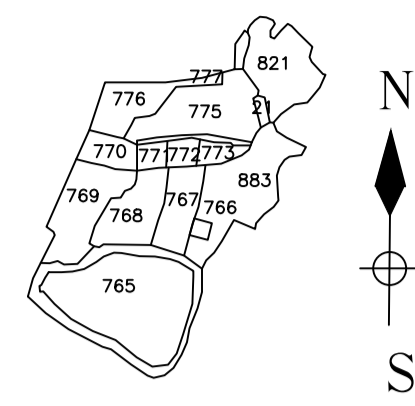
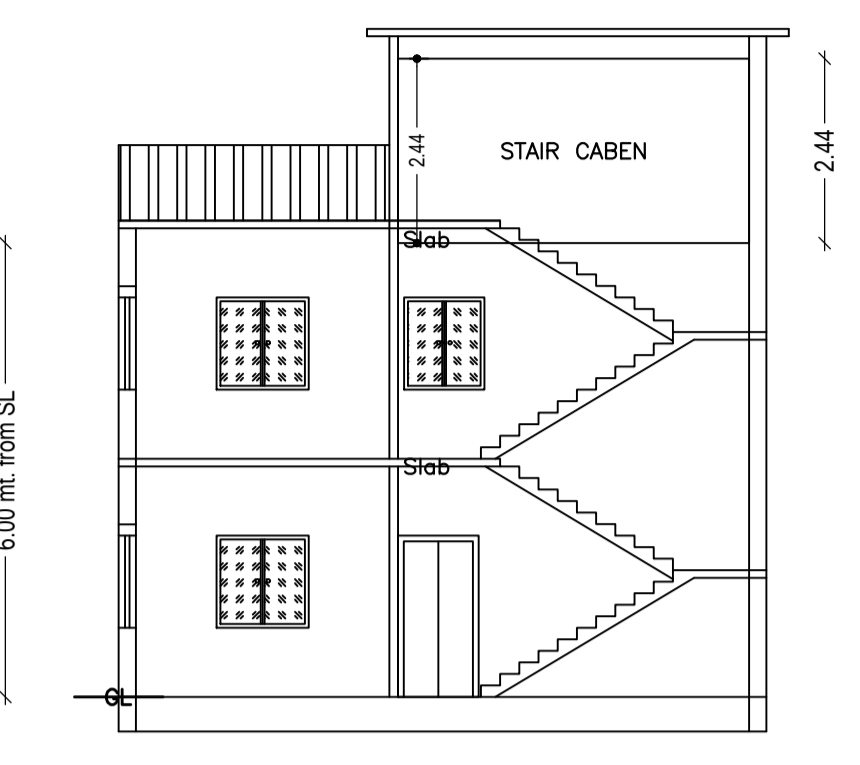

SECTION ON: 'A-A'
SCALE - 1:100

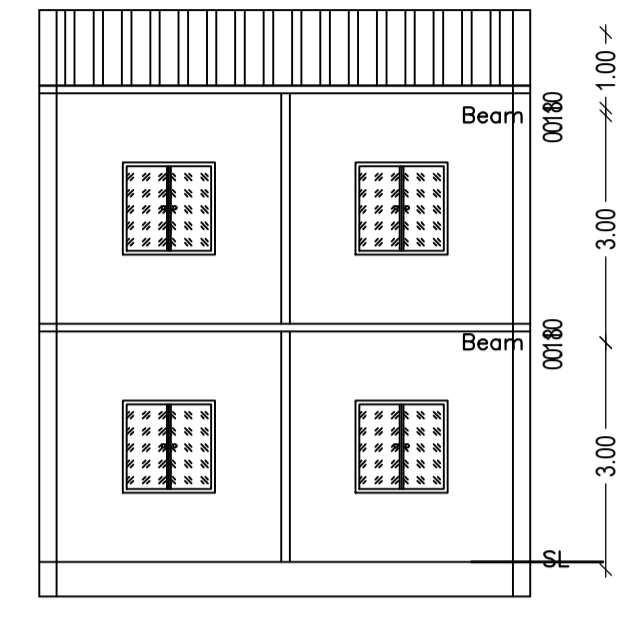

SECTION ON: 'B-B'
SCALE - 1:100

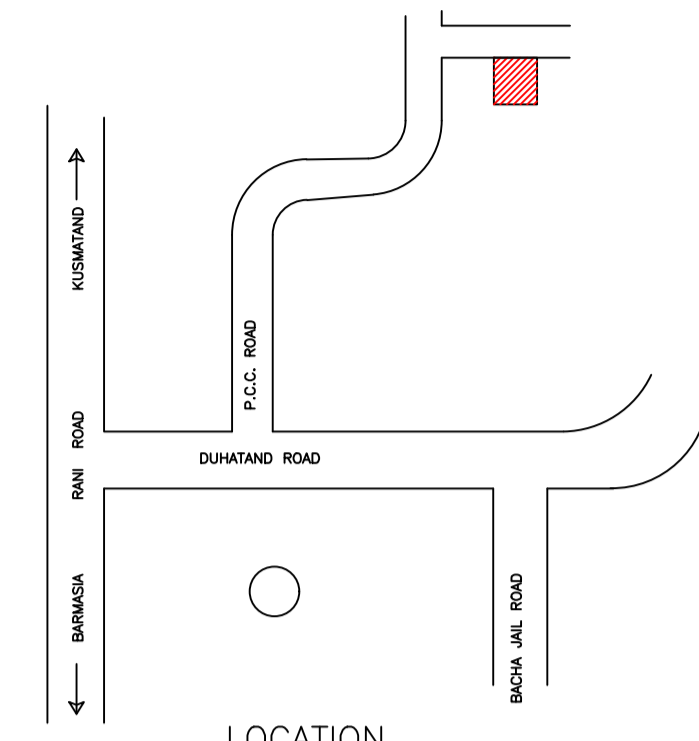

LOCATION
SCALE - NTS

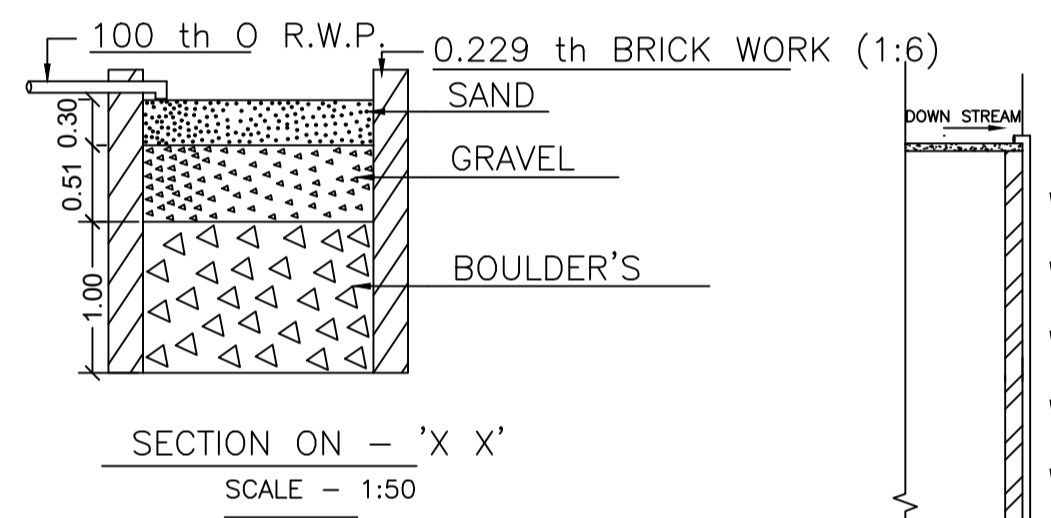

SECTION ON - 'X X'
SCALE - 1:50

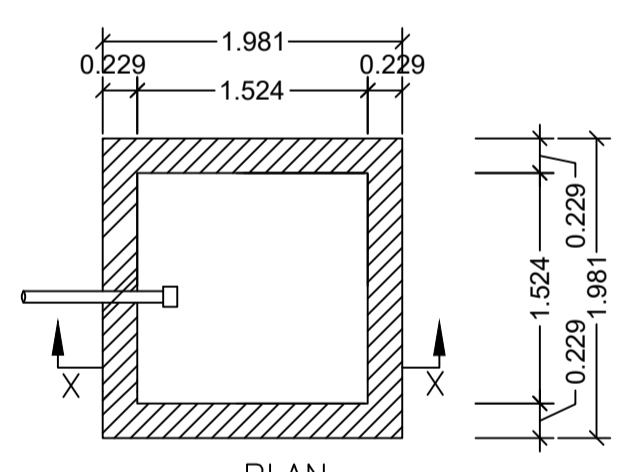

DETAILS OF WATER HARVESTING
SCALE - 1:50

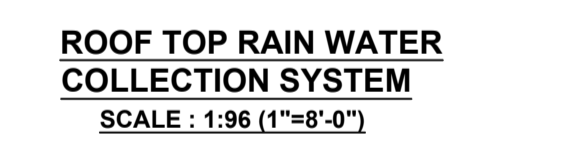

ROOF TOP RAIN WATER COLLECTION SYSTEM
SCALE : 1:96 (1"=8'-0")

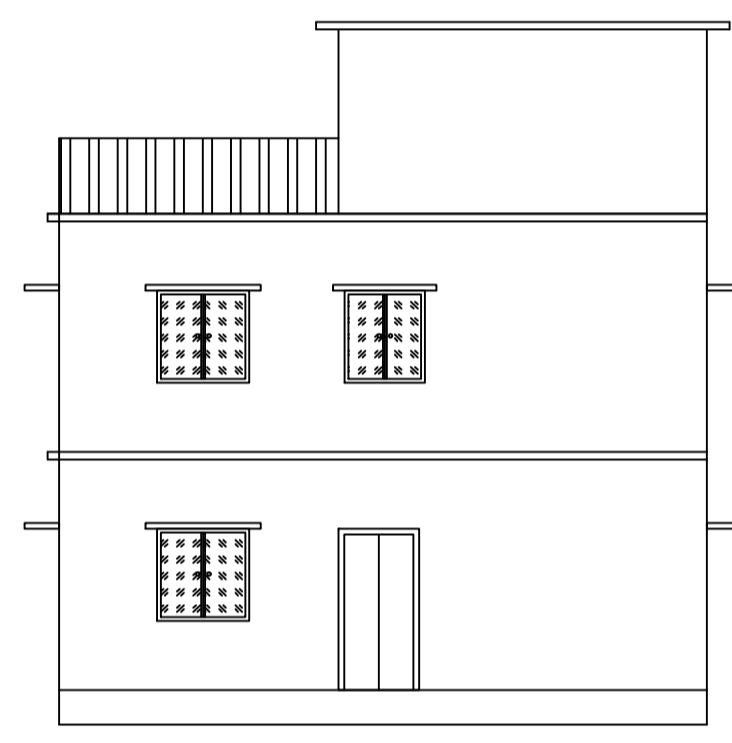

FRONT ELEVATION
SCALE - 1:100

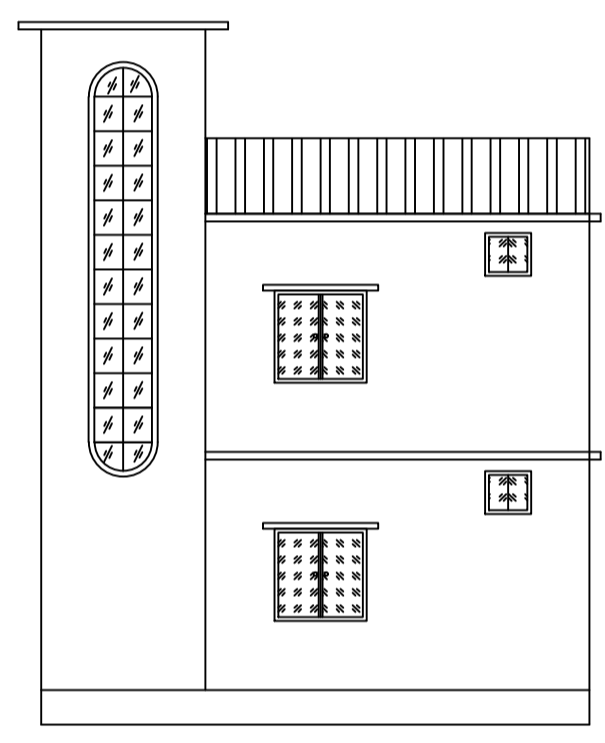

RIGHT SIDE ELEVATION
SCALE - 1:100

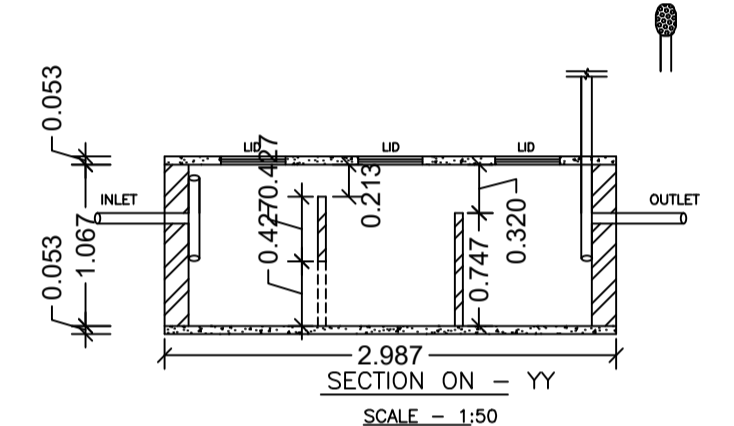

SECTION ON - YY
SCALE - 1:50

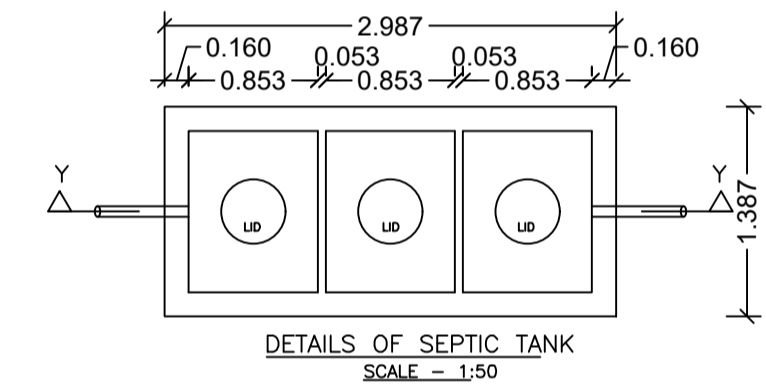

DETAILS OF SEPTIC TANK
SCALE - 1:50

SCHEDULE OF DOOR:

| BUILDING NAME | NAME | LENGTH | HEIGHT | NOS |
|---------------|------|--------|--------|-----|
| A (A) | D | 0.75 | 2.10 | 02 |
| A (A) | D | 0.76 | 2.10 | 04 |
| A (A) | D | 0.91 | 2.10 | 04 |

SCHEDULE OF WINDOW/VENTILATION:

| BUILDING NAME | NAME | LENGTH | HEIGHT | NOS |
|---------------|------|--------|--------|-----|
| A (A) | V | 0.61 | 1.20 | 06 |
| A (A) | W | 1.06 | 1.20 | 03 |
| A (A) | W | 1.22 | 1.20 | 10 |

Building :A (A)

| Floor Name | Total Built Up Area (Sq.mt.) | Proposed FAR Area (Res.) (Sq.mt.) | Total FAR Area (Sq.mt.) | Total Consumed Additional FAR Area (Sq.mt.) | Trmt (No.) |
|----------------------------------|------------------------------|-----------------------------------|-------------------------|---|------------|
| Ground Floor | 55.39 | 55.39 | 55.39 | 55.39 | 01 |
| First Floor | 55.39 | 55.39 | 55.39 | 55.39 | 00 |
| Terrace Floor | 0.00 | 0.00 | 0.00 | 0.00 | 00 |
| Total : | 110.78 | 110.78 | 110.78 | 110.78 | 01 |
| Total Number of Same Buildings : | 1 | | | | |
| Total : | 110.78 | 110.78 | 110.78 | 110.78 | 01 |

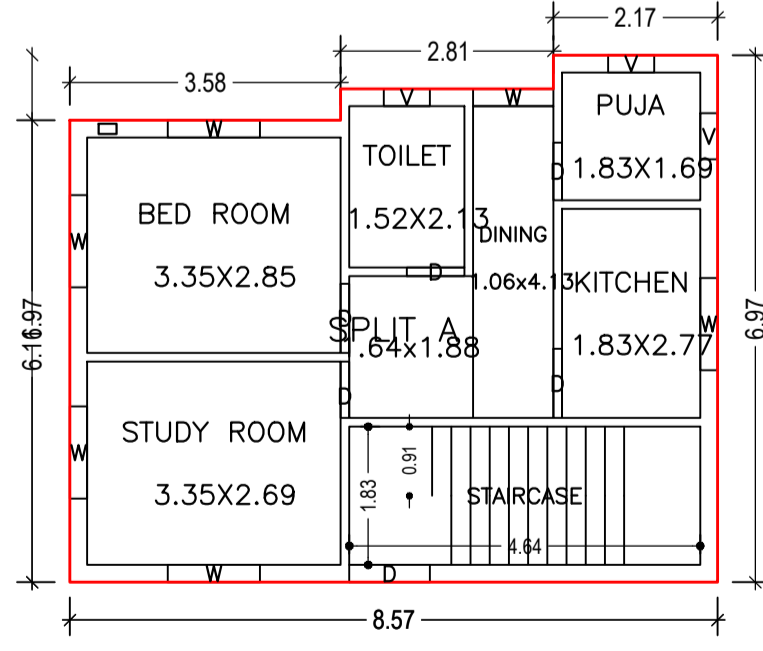

GROUND FLOOR PLAN (Proposed)
SCALE 1:100

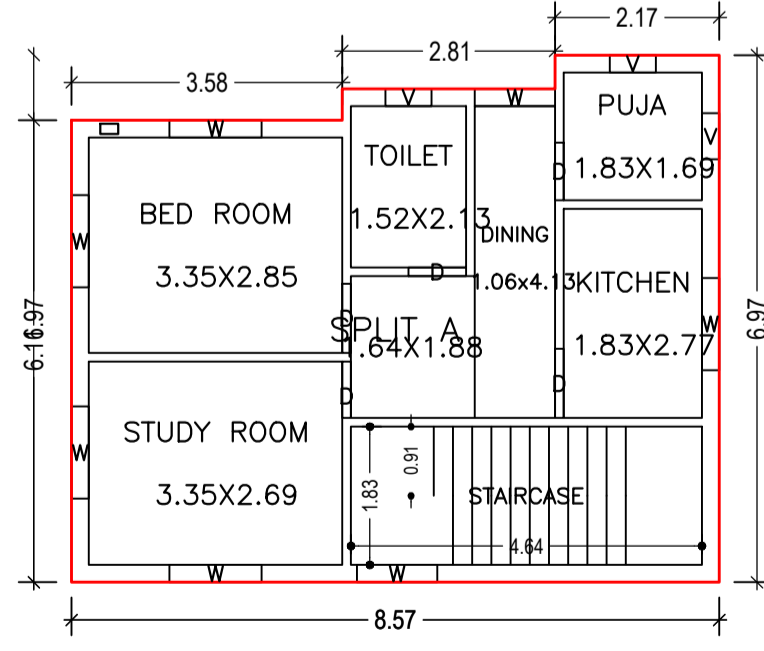

FIRST FLOOR PLAN (Proposed)
SCALE 1:100

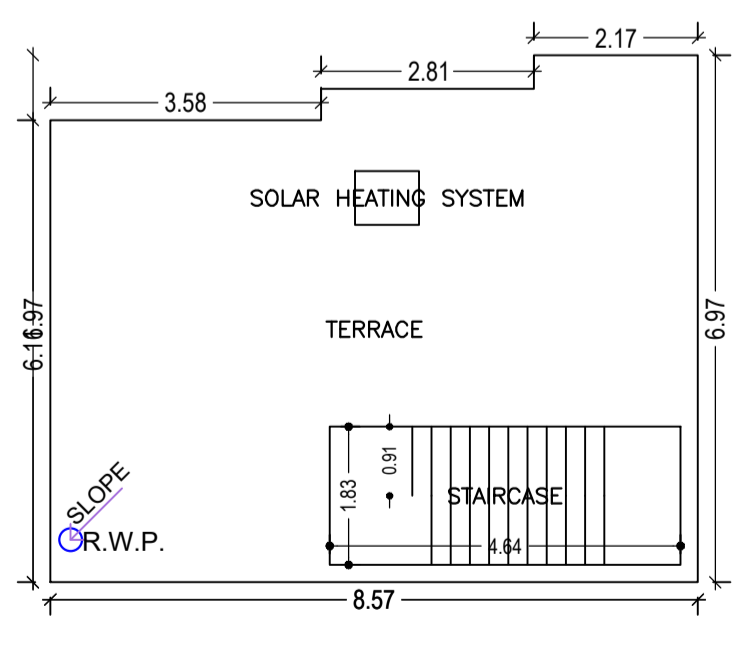

TERRACE FLOOR PLAN (SCALE 1:100)

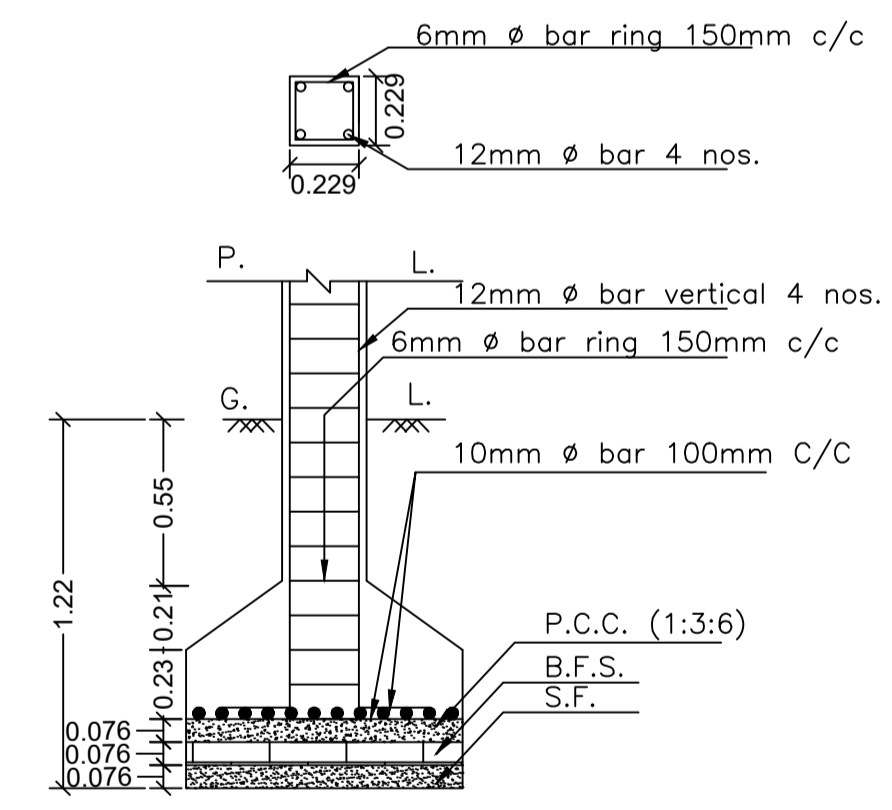

SECTION ON - ZZ
SCALE - 1:25

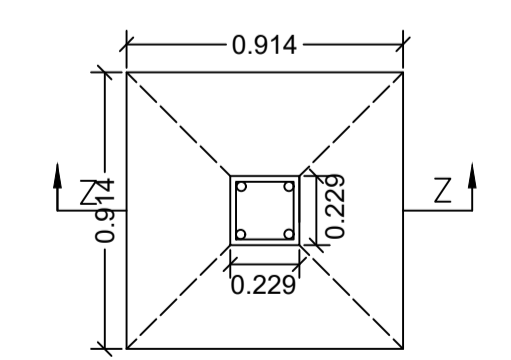

DETAILS OF COLUMN FOOTING
SCALE - 1:25

| AREA STATEMENT | | VERSION NO. : 1.0/2 |
|--|---|--------------------------|
| DHANBAD MUNICIPAL CORPORATION | | VERSION DATE: 16/10/2020 |
| PROJECT DETAIL: | | |
| Region: JHARKHAND URBAN LOCAL BODIES | Plot Use: Residential | |
| District: DHANBAD | Plot SubUse: Bungalow/ Dwelling / Non Apartment | |
| Authority: DHANBAD MUNICIPAL CORPORATION | PlotNearbyReligiousStructure: NA | |
| Inward No: DMC/BP/0186/W29/2022 | Plot/SubPlot No: OLD-766 NEW-556 | |
| Application Type: General Proposal | North: Plot No. - PART OF SAME PLOT | |
| Project Type: Building Permission | South: Road Width - 3.04 | |
| Nature of Development: New | East: Plot No. - PART OF SAME PLOT | |
| Location of Development Area: Old Area | West: Plot No. - 767 | |
| AREA DETAILS: | | |
| AREA OF PLOT (Minimum) | (A) | SQ.MT. 92.83 |
| Deduction for NetPlot Area | | |
| Surrender Free of Cost | | 2.76 |
| Total | | 2.76 |
| NET AREA OF PLOT(Gross Plot Area - Deduction from Gross Plot area) | (A-Deductions) | 90.07 |
| Deduction for Balance Plot Area(from Gross Plot Area) | | |
| Surrender Free of Cost | | 2.76 |
| Common Plot | | 6.15 |
| Total | | 8.91 |
| BALANCE AREA OF PLOT(Net Plot Area - Recreational/Amenity space) | (A-Deductions) | 83.93 |
| PLOT AREA FOR COVERAGE(Net Plot Area) | (A-Deductions) | 90.07 |
| Plot Area for FAR (Net Plot Area + RoadWidening Area) | (A-Deductions) | 92.83 |
| COVERAGE CHECK | | |
| Permissible Coverage area (70.00 %) | | 63.05 |
| Proposed Coverage Area (61.49 %) | | 55.39 |
| Total Prop. Coverage Area (61.49 %) | | 55.39 |
| Balance coverage area (8.50 %) | | 7.66 |
| FAR CHECK | | |
| Perm. FAR Area (1.20) | | 114.40 |
| Total Perm. FAR area | | 114.40 |
| Residential FAR | | 110.78 |
| Proposed FAR Area | | 110.78 |
| Total Proposed FAR Area | | 110.78 |
| Consumed FAR (Factor) | | 1.19 |
| Balance FAR Area | | 0.62 |
| BUILT UP AREA CHECK | | |
| Total Proposed BuiltUp Area | | 110.78 |
| ARCHITECT (Regd) SANJEEV KUMAR RAY | | |
| ENGINEER (Regd) | | |
| SUPERVISOR (Regd) | | |
| OWNER (Regd) KHUSHBU SINGH | | |
| DEVELOPMENT AUTHORITY | | LOCAL BODY |

COLOR INDEX

| | |
|-----------------------------|------------|
| PLOT BOUNDARY | Black |
| ABUTTING ROAD | Green |
| PROPOSED CONSTRUCTION | Red |
| COMMON PLOT | Yellow |
| ROAD WIDENING AREA | Blue |
| EXISTING (To be retained) | Light Blue |
| EXISTING (To be demolished) | Dark Blue |

Buildingwise Floor FAR Details

| Floor Name | Building Name A (A) | | Total | |
|---------------|---------------------------------|----------------------------|---------------------------------------|-------------------------|
| | Proposed Built Up Area (Sq.mt.) | Proposed FAR Area (Sq.mt.) | Total Proposed Built Up Area (Sq.mt.) | Total FAR Area (Sq.mt.) |
| Ground Floor | 55.39 | 55.39 | 55.39 | 55.39 |
| First Floor | 55.39 | 55.39 | 55.39 | 55.39 |
| Terrace Floor | 0.00 | 0.00 | 0.00 | 0.00 |
| Total : | 110.78 | 110.78 | 110.78 | 110.78 |

Building USE/SUBUSE Details

| Building Name | Building Use | Building SubUse | Building Structure |
|---------------|--------------|----------------------------|--------------------|
| A (A) | Residential | Residential Bldg/Apartment | Non-Highrise |

FAR & Tenement Details (Table 4c-1)

| Building | No. of Same Bldg | Total Built Up Area (Sq.mt.) | Proposed FAR Area (Sq.mt.) | Total FAR Area (Sq.mt.) | Total Consumed Additional FAR Area (Sq.mt.) | Trmt (No.) |
|---------------|------------------|------------------------------|----------------------------|-------------------------|---|------------|
| A (A) | 1 | 110.78 | 110.78 | 110.78 | 110.78 | 01 |
| Grand Total : | 1 | 110.78 | 110.78 | 110.78 | 110.78 | 01 |

UnitBUA Table for Building :A (A)

| FLOOR | Name | UnitBUA Type | UnitBUA Area | Carpet Area | No. of Rooms | No. of Tenement |
|--------------|---------|--------------|--------------|-------------|--------------|-----------------|
| GROUND FLOOR | SPLIT A | FLAT | 110.78 | 110.72 | 6 | 1 |
| FIRST FLOOR | SPLIT A | FLAT | 0.00 | 0.00 | 6 | 0 |
| PLAN | | | | | | |
| Total: | | | 110.78 | 110.72 | 12 | 1 |

| | | | |
|--|-------------------------------------|----------------------------|-------------------|
| LTP NAME AND SIGNATURE SANJEEV KUMAR RAY DMC/ENG/0001/2019 | STRUCTURAL ENG'S NAME AND SIGNATURE | BUILDER NAME AND SIGNATURE | DIGITAL SIGNATURE |
|--|-------------------------------------|----------------------------|-------------------|