

Proposal Basic Information

Proposal File No.	DMC/BI/0372/W24/2022
Owner Name	SHIV BAHADUR
Khata No	OLD-77, NEW-163
Plot No	OLD-3370, NEW-2185
Village Name	Saraidhela
Use	Residential
SubUse	Bungalow/ Dwelling / Non Apartment

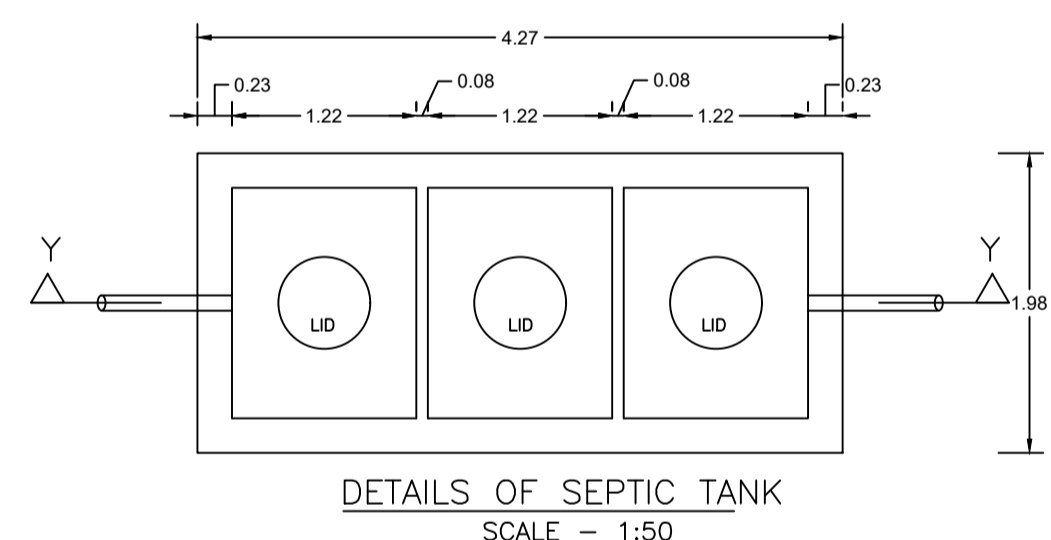
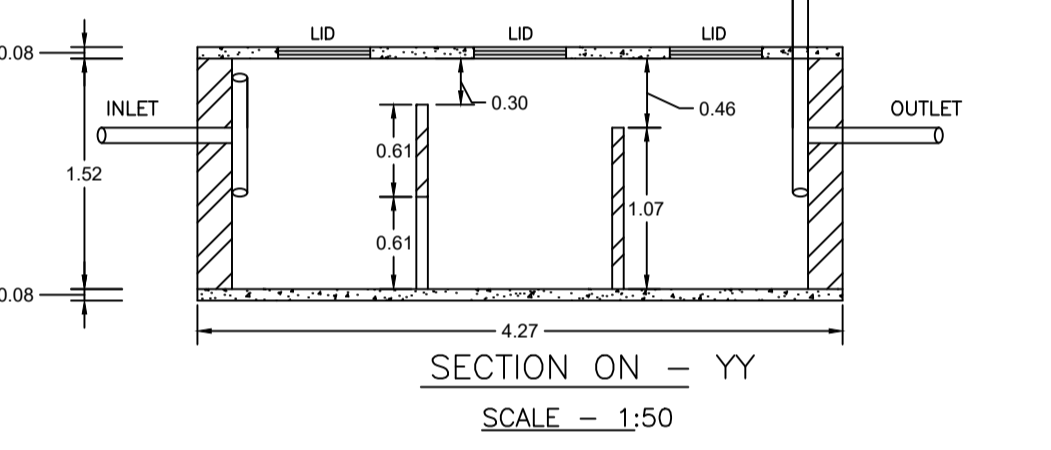
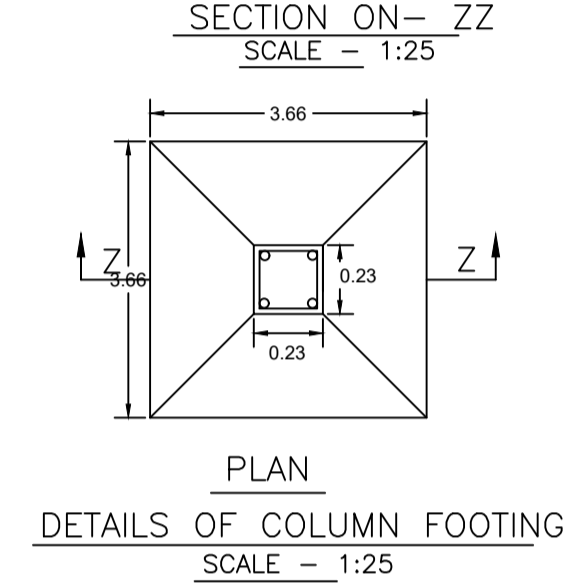
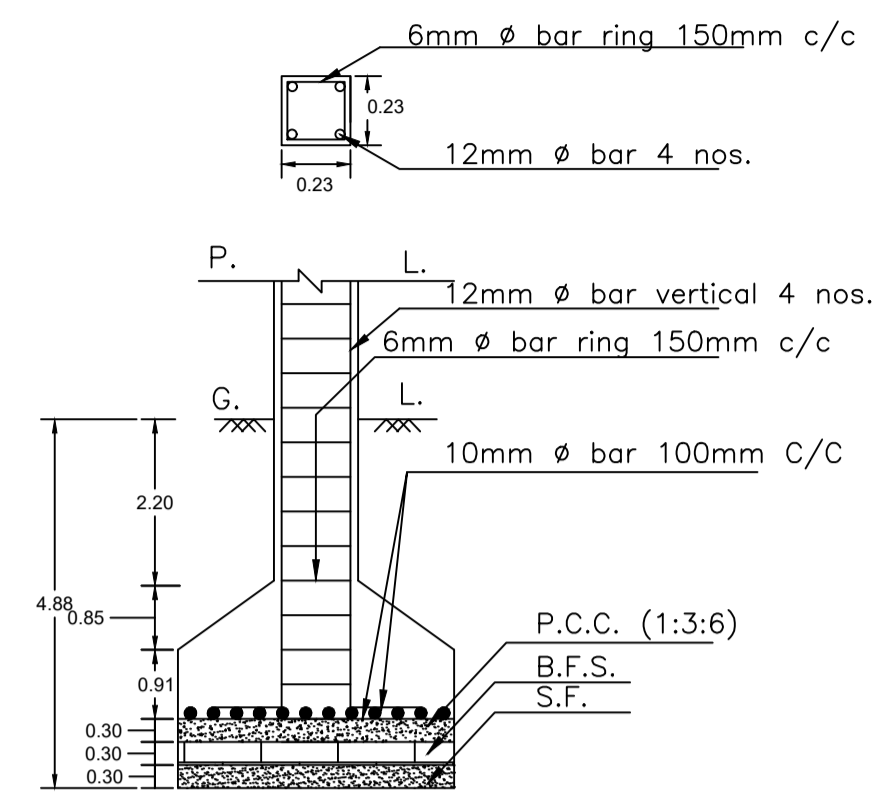
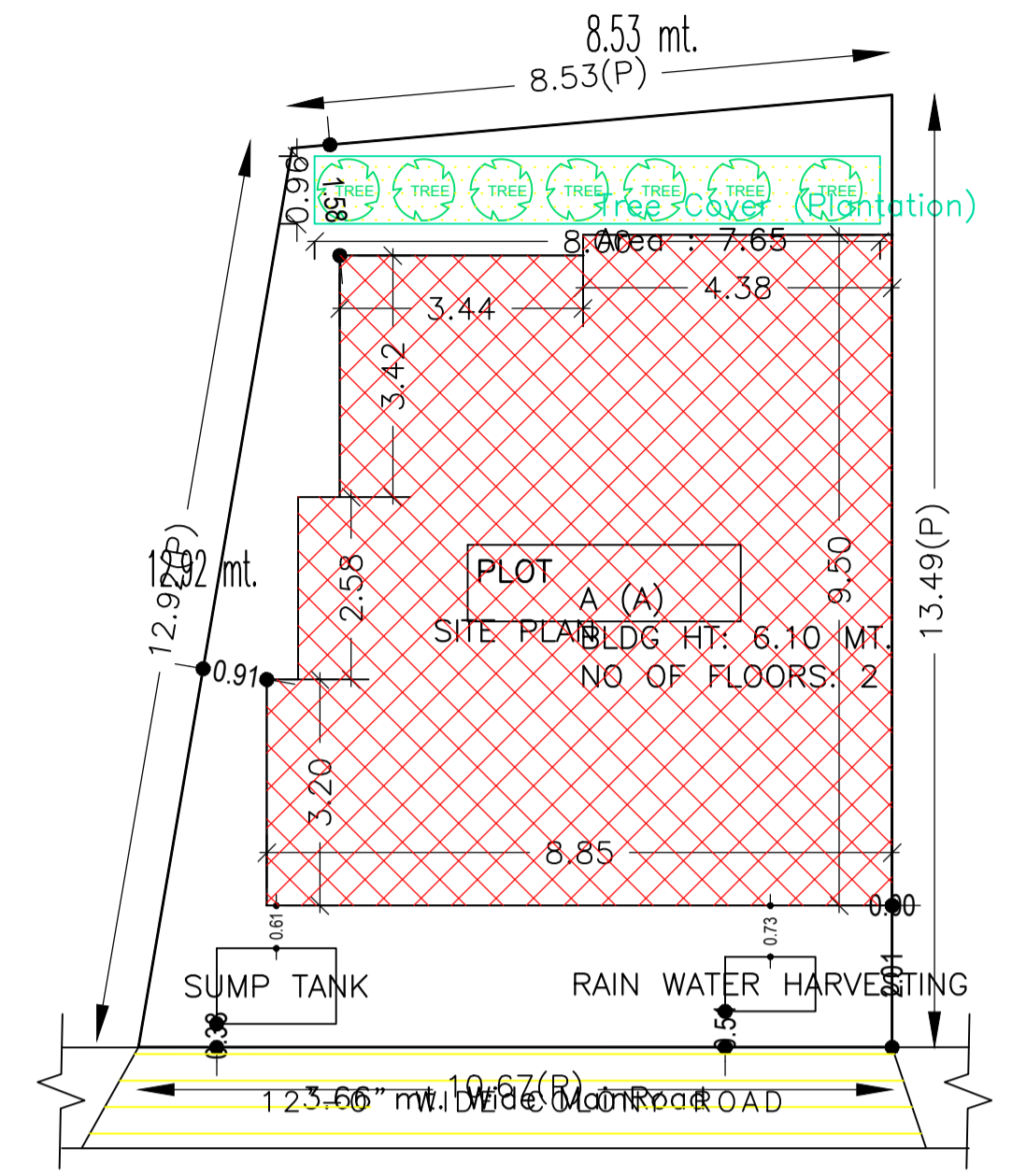
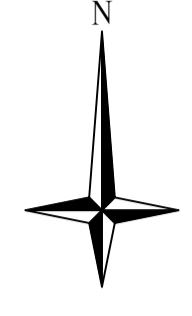

Building :A (A)

Floor Name	Total Built Up Area (Sq.mt.)	Proposed FAR Area (Sq.mt. Resi.)	Total FAR Area (Sq.mt.)	Total Consumed Additional FAR Area (Sq.mt.)	Tnmt (No.)
Ground Floor	78.09	78.09	78.09	78.09	01
First Floor	78.09	78.09	78.09	78.09	00
Terrace Floor	0.00	0.00	0.00	0.00	00
Total :	156.18	156.18	156.18	156.18	01
Total Number of Same Buildings :	1				
Total :	156.18	156.18	156.18	156.18	01

SCHEDULE OF DOOR:

BUILDING NAME	NAME	LENGTH	HEIGHT	NOS
A (A)	D	0.76	2.10	02
A (A)	D	0.92	2.10	04
A (A)	D	1.06	2.10	02
A (A)	D	1.07	2.10	05

SCHEDULE OF WINDOW/VENTILATION:

BUILDING NAME	NAME	LENGTH	HEIGHT	NOS
A (A)	V	0.61	1.20	02
A (A)	W	1.22	1.20	10
A (A)	W	1.74	1.20	01
A (A)	W	2.07	1.20	01

UnitBUA Table for Building :A (A)

FLOOR	Name	UnitBUA Type	UnitBUA Area	Carpet Area	No. of Rooms	No. of Tenement
GROUND FLOOR PLAN	SPLIT A	FLAT	156.17	156.11	7	1
FIRST FLOOR PLAN	SPLIT A	FLAT	0.00	0.00	7	0
Total:	-	-	156.17	156.11	14	1

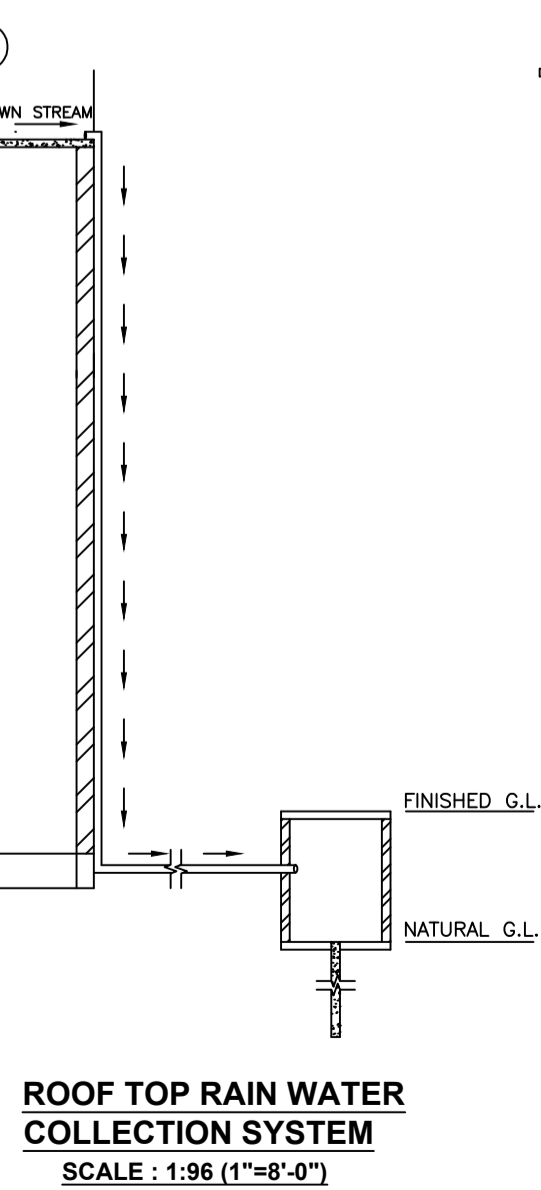
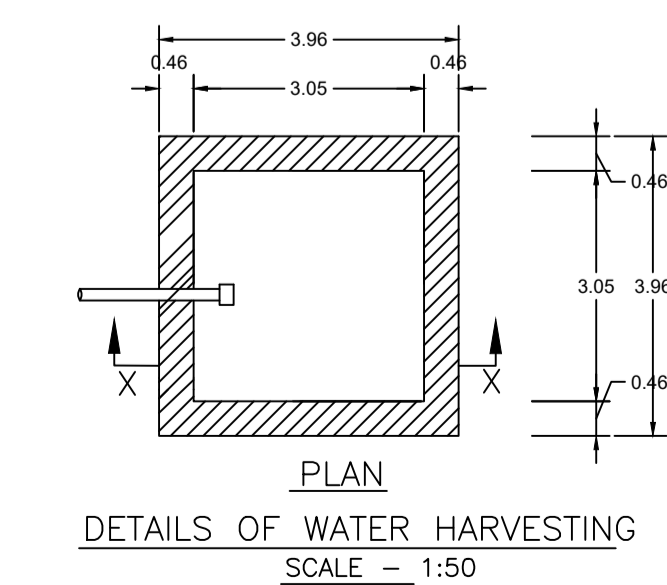
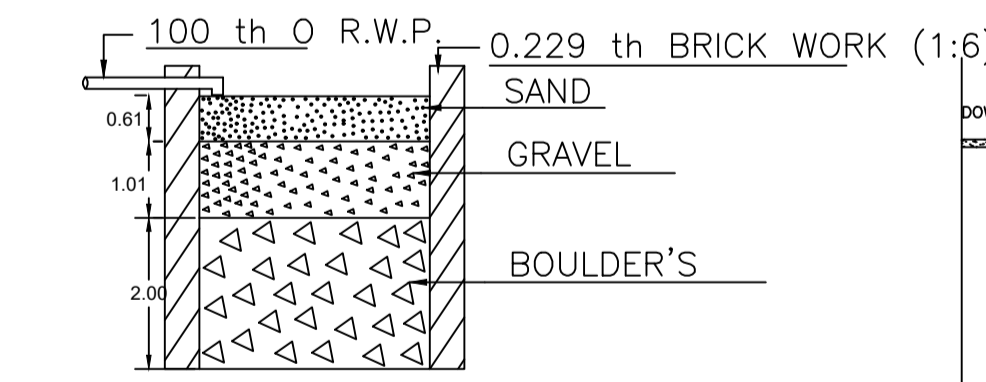

ROOF TOP RAIN WATER COLLECTION SYSTEM
SCALE: 1:98 (1"=8'-0")

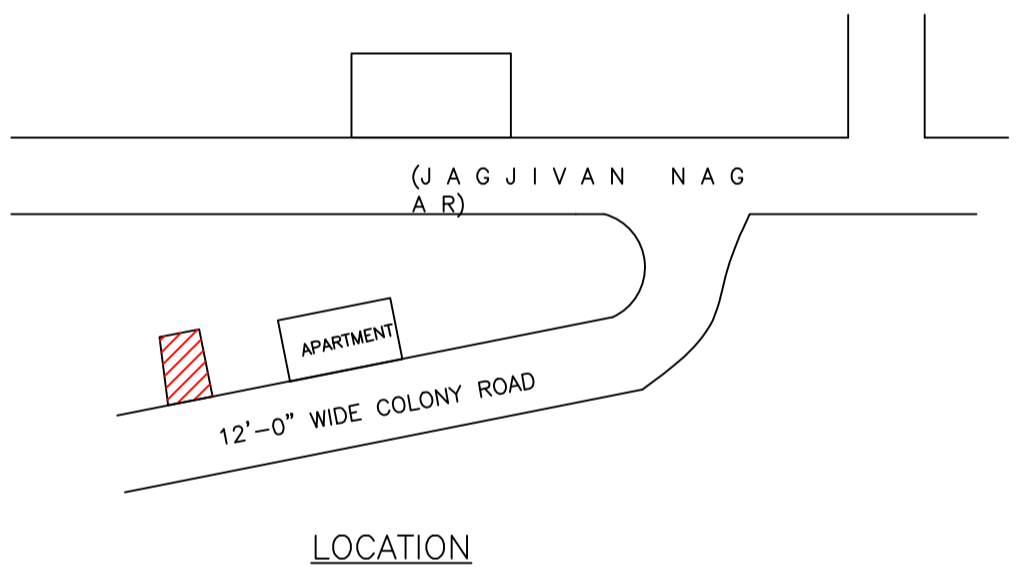

LOCATION

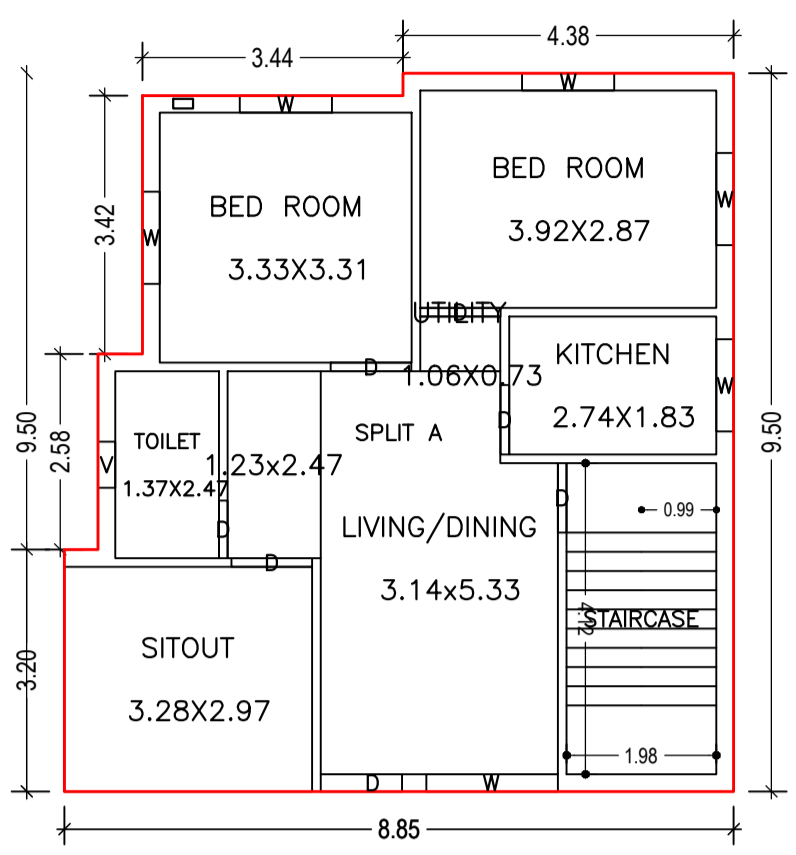

GROUND FLOOR PLAN (Proposed)
SCALE: 1:100

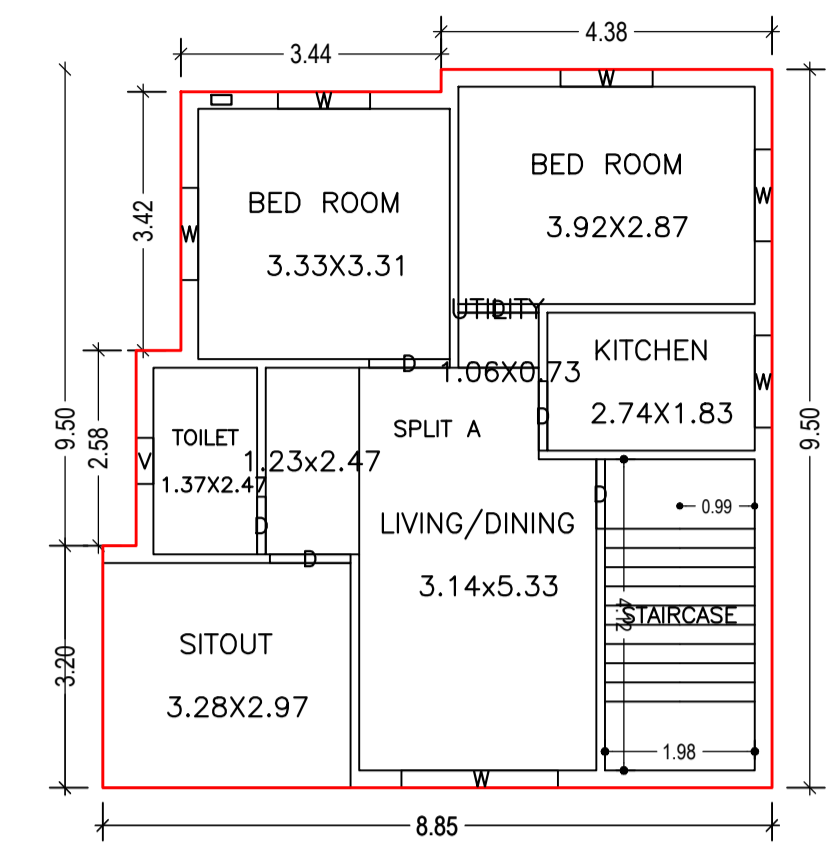

FIRST FLOOR PLAN (Proposed)
SCALE: 1:100

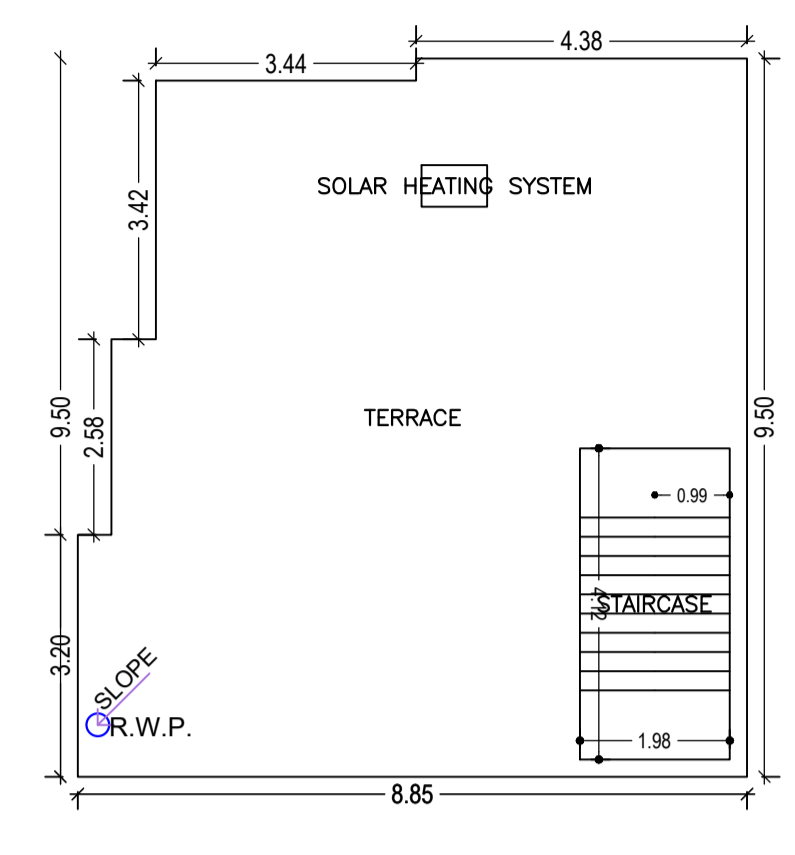

TERRACE FLOOR PLAN (SCALE: 1:100)

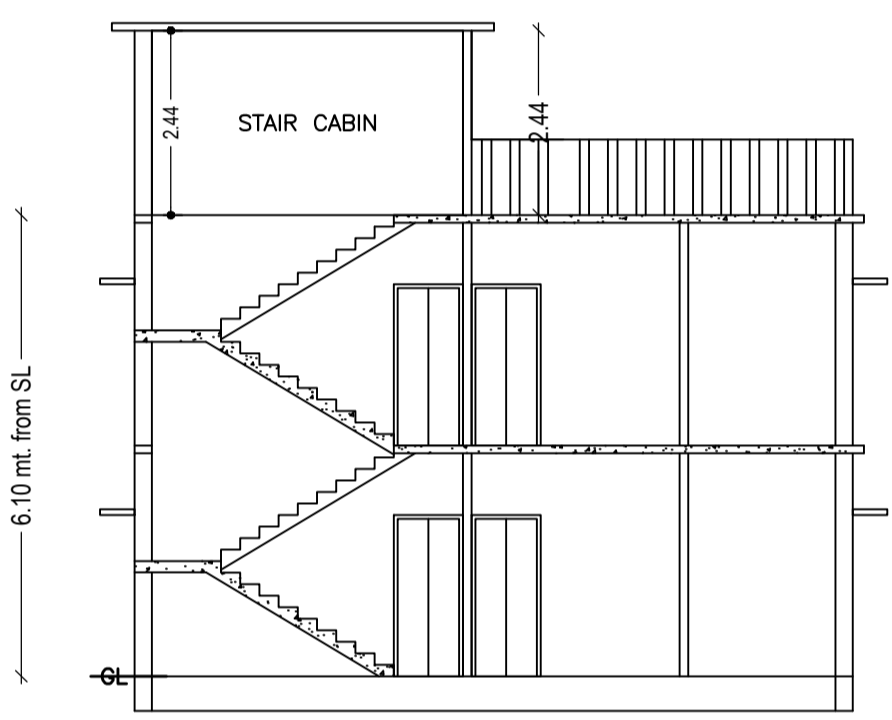

SECTION ON: 'A-A'
SCALE: 1:100

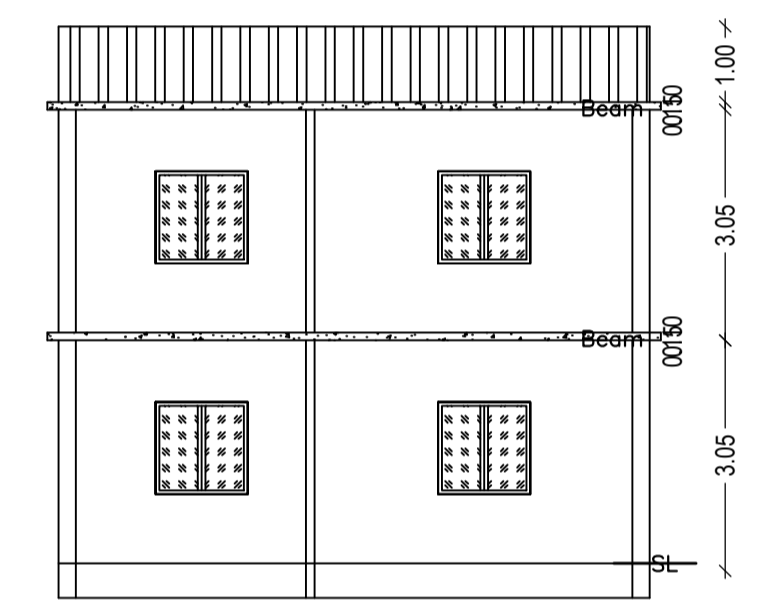

SECTION ON: 'B-B'
SCALE: 1:100

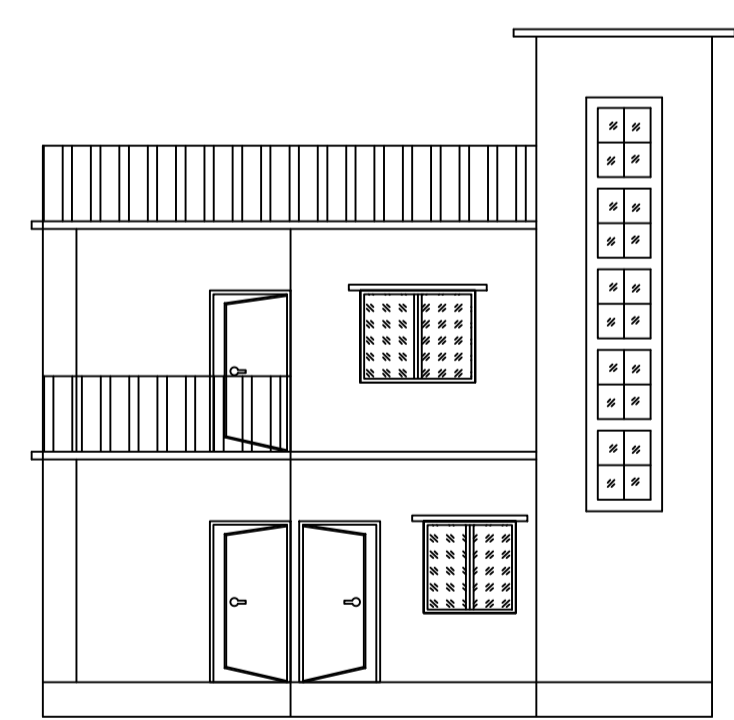

FRONT ELEVATION
SCALE: 1:100

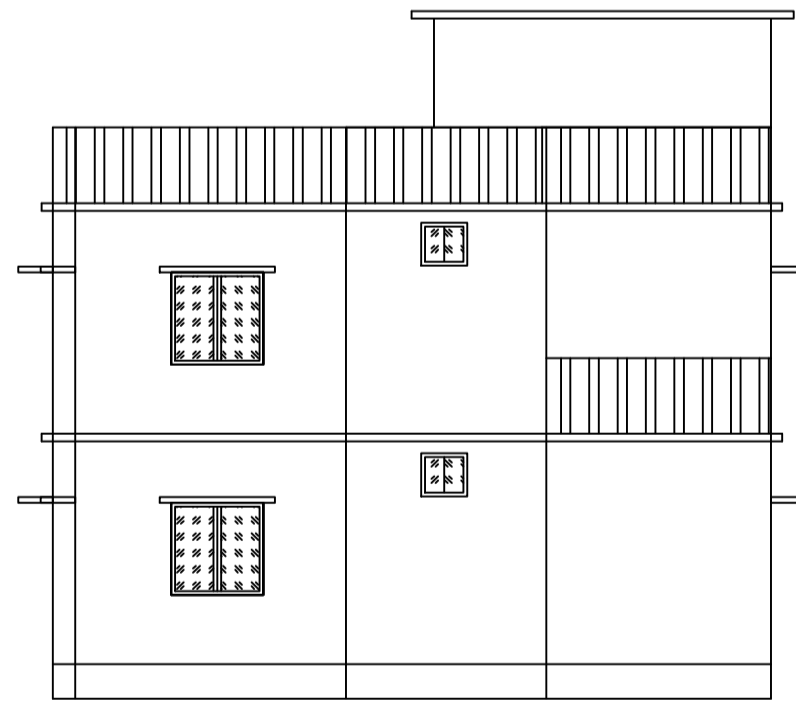

LEFT SIDE ELEVATION
SCALE: 1:100

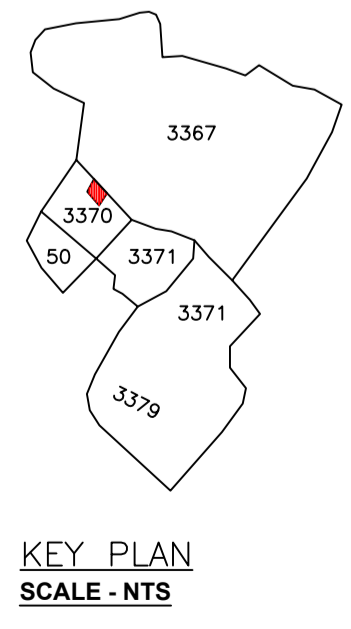

KEY PLAN
SCALE: NTS

AREA STATEMENT		VERSION NO.:	1.0.64
DHANBAD MUNICIPAL CORPORATION		VERSION DATE: 16/10/2020	
PROJECT DETAIL:			
Region: JHARKHAND URBAN LOCAL BODIES	Plot Use: Residential		
District: DHANBAD	Plot SubUse: Bungalow/ Dwelling / Non Apartment		
Authority: DHANBAD MUNICIPAL CORPORATION	PlotNearby/ReligiousStructure: NA		
Inward No: DMC/BI/0372/W24/2022	Plot/SubPlot No: OLD-3370, NEW-2185		
Application Type: General Proposal	North: Plot No. - BCCL BOUNDARY		
Project Type: Building Permission	South: Road Width - 3.66		
Nature of Development: New	East: Plot No. - S.K. BHOWMICK		
Location of Development Area: Old Area	West: Plot No. - TAPAN JYOTI BISWAS		
AREA DETAILS:			
AREA OF PLOT (Minimum)	(A)	SQ.MT. 125.21	
NET AREA OF PLOT(Gross Plot Area - Deduction from Gross Plot area)	(A-Deductions)	125.21	
Deduction for Balance Plot Area(from Gross Plot Area)			
Common Plot		7.65	
Total		7.65	
BALANCE AREA OF PLOT(Net Plot Area - Recreational/Amenity space)	(A-Deductions)	117.56	
PLOT AREA FOR COVERAGE(Net Plot Area)	(A-Deductions)	125.21	
Plot Area for FAR (Net Plot Area + RoadWidening Area)	(A-Deductions)	125.21	
COVERAGE CHECK			
Permissible Coverage area (70.00 %)		87.65	
Proposed Coverage Area (62.37 %)		78.09	
Total Prop. Coverage Area (62.37 %)		78.09	
Balance coverage area (7.64 %)		9.56	
FAR CHECK			
Perm. FAR Area (1.500)		187.82	
Total Perm. FAR area		187.82	
Residential FAR		156.17	
Proposed FAR Area		156.17	
Total Proposed FAR Area		156.17	
Consumed FAR (Factor)		1.25	
Balance FAR Area		31.65	
BUILT UP AREA CHECK			
Total Proposed BuiltUp Area		156.18	
ARCHITECT (Regd)	SANJEEV KUMAR RAY		
ENGINEER (Regd)			
SUPERVISOR (Regd)			
OWNER (Regd)	SHIV BAHADUR		
DEVELOPMENT AUTHORITY		LOCAL BODY	

COLOR INDEX

PLOT BOUNDARY	Black
ABUTTING ROAD	Red
PROPOSED CONSTRUCTION	Green
COMMON PLOT	Yellow
ROAD WIDENING AREA	Blue
EXISTING (To be retained)	Orange
EXISTING (To be demolished)	Light Blue

Buildingwise Floor FAR Details

Floor Name	Building Name A (A)		Total	
	Proposed Built Up Area (Sq.mt.)	Proposed FAR Area (Sq.mt.)	Total Proposed Built Up Area (Sq.mt.)	Total FAR Area (Sq.mt.)
Ground Floor	78.09	78.09	78.09	78.09
First Floor	78.09	78.09	78.09	78.09
Terrace Floor	0.00	0.00	0.00	0.00
Total :	156.18	156.18	156.18	156.18

Building USE/SUBUSE Details

Building Name	Building Use	Building SubUse	Building Structure
A (A)	Residential	Bungalow/ Dwelling / Non Apartment	Non-Highrise

FAR & Tenement Details (Table 4c-1)

Building	No. of Same Bldg	Total Built Up Area (Sq.mt.)	Proposed FAR Area (Sq.mt. Resi.)	Total FAR Area (Sq.mt.)	Total Consumed Additional FAR Area (Sq.mt.)	Tnmt (No.)
A (A)	1	156.18	156.18	156.18	156.18	01
Grand Total :	1	156.18	156.18	156.18	156.18	01

LTP NAME AND SIGNATURE	STRUCTURAL ENG'S NAME AND SIGNATURE	BUILDER NAME AND SIGNATURE	DIGITAL SIGNATURE
SANJEEV KUMAR RAY DMC/ENG/0001/2019			

Proposal Basic Information	
Proposal File No.	DMC/BP/0372/W24/2022
Owner Name	SHIV BAHADUR
Khata No	OLD-77, NEW-163
Plot No	OLD-3370, NEW-2185
Village Name	Saraidhela
Use	Residential
SubUse	Bungalow/ Dwelling / Non Apartment

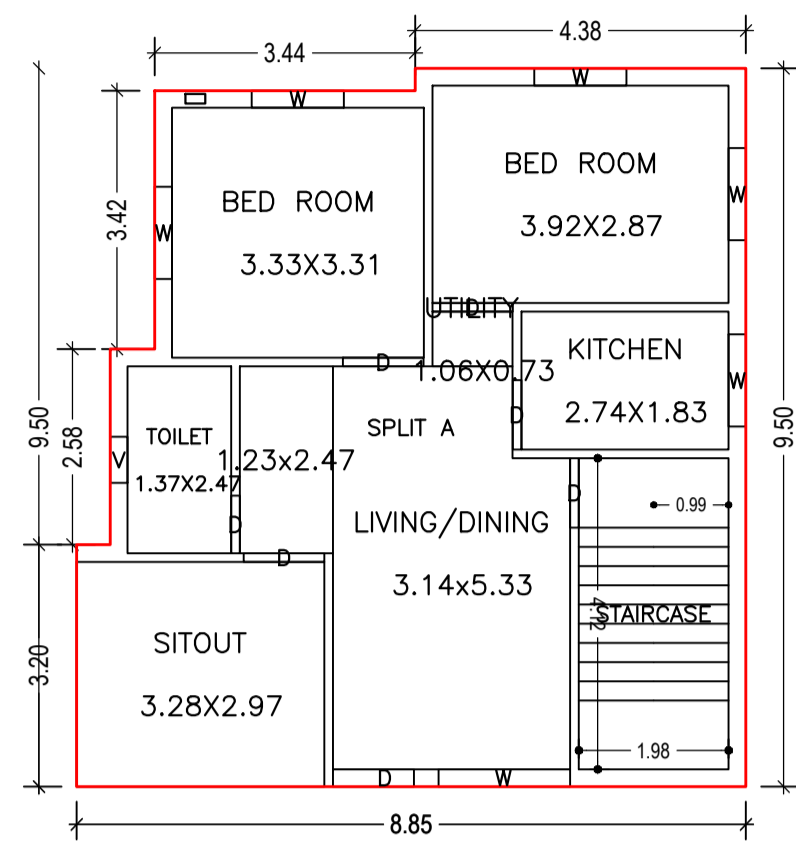

GROUND FLOOR PLAN
(Proposed)
SCALE 1:100

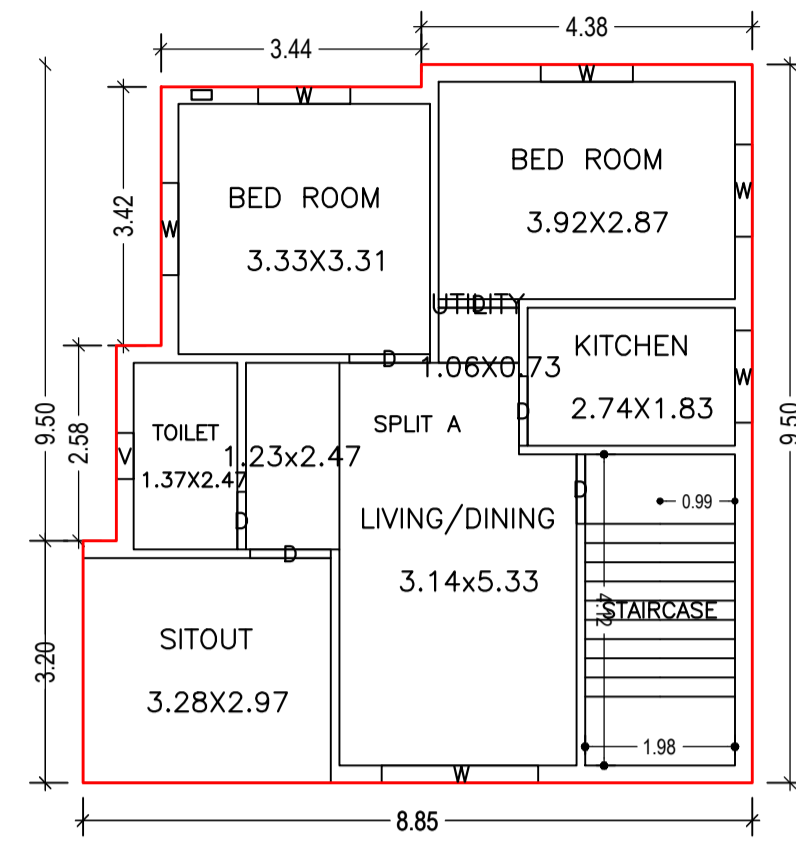

FIRST FLOOR PLAN
(Proposed)
SCALE 1:100

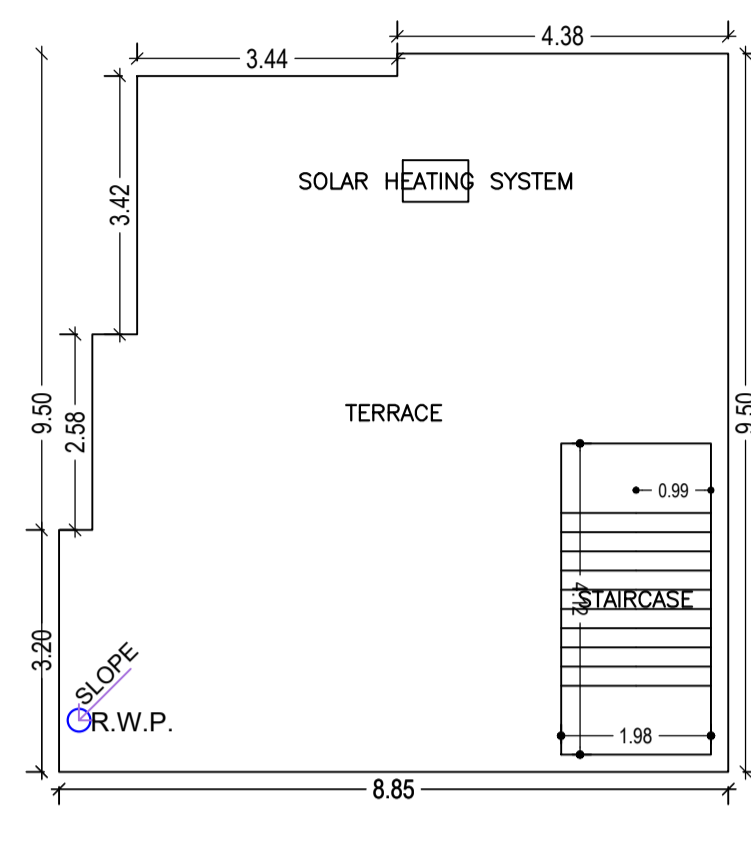

TERRACE FLOOR PLAN
(SCALE 1:100)

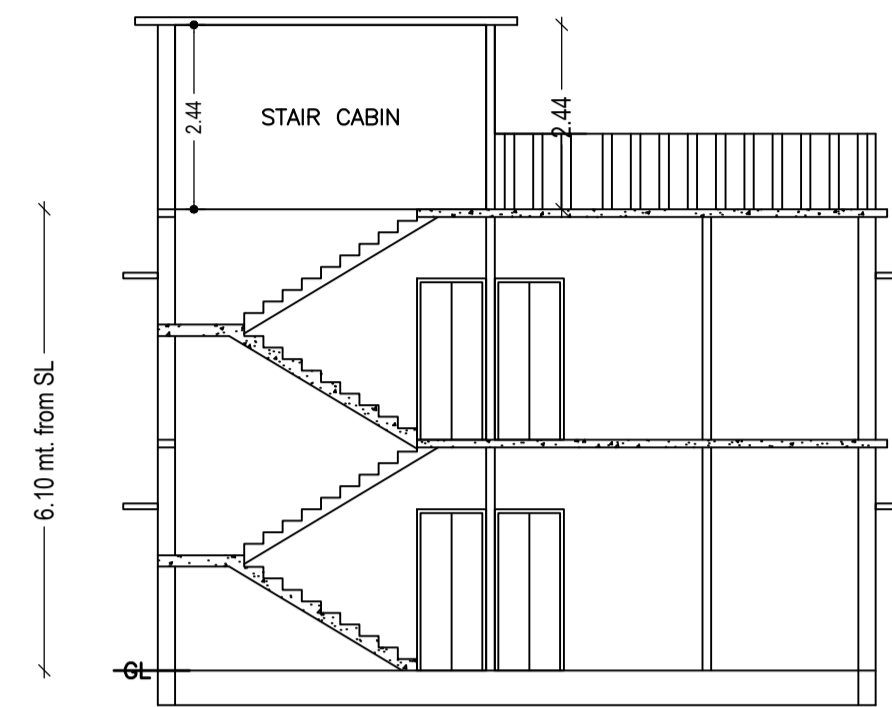

SECTION ON: 'A-A'
SCALE - 1:100

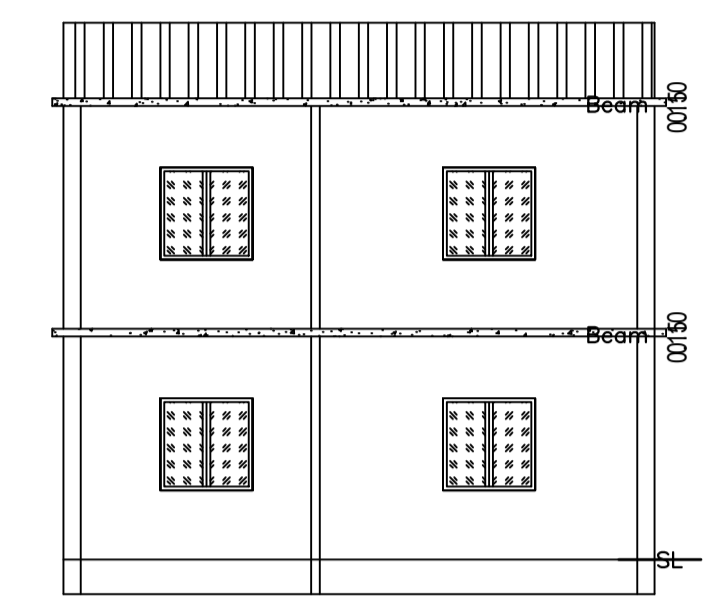

SECTION ON: 'B-B'
SCALE - 1:100

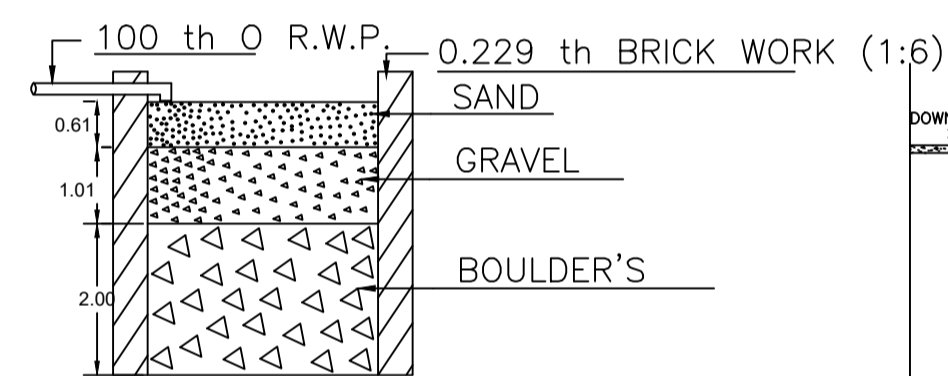
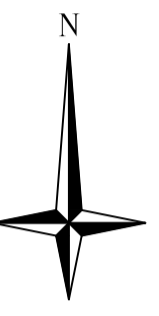

SECTION ON - 'X X'
SCALE - 1:50

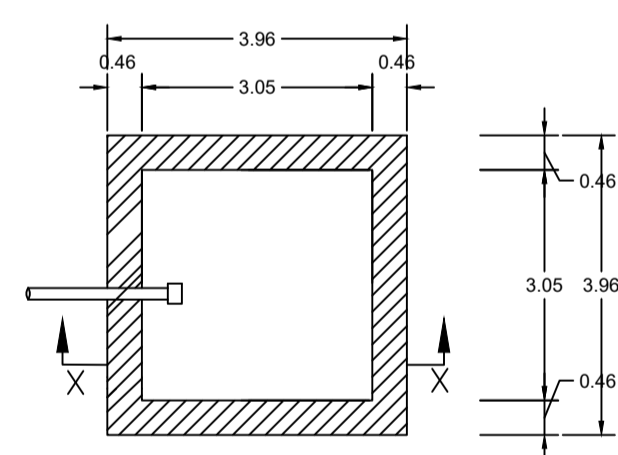

PLAN
DETAILS OF WATER HARVESTING
SCALE - 1:50

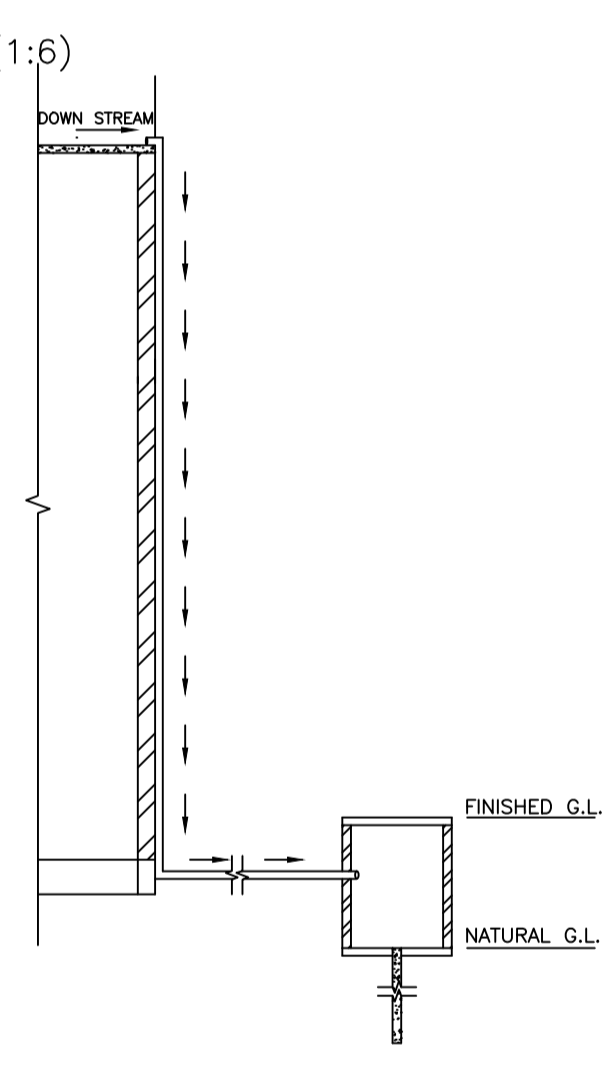

ROOF TOP RAIN WATER
COLLECTION SYSTEM
SCALE: 1:96 (1"=8'-0")

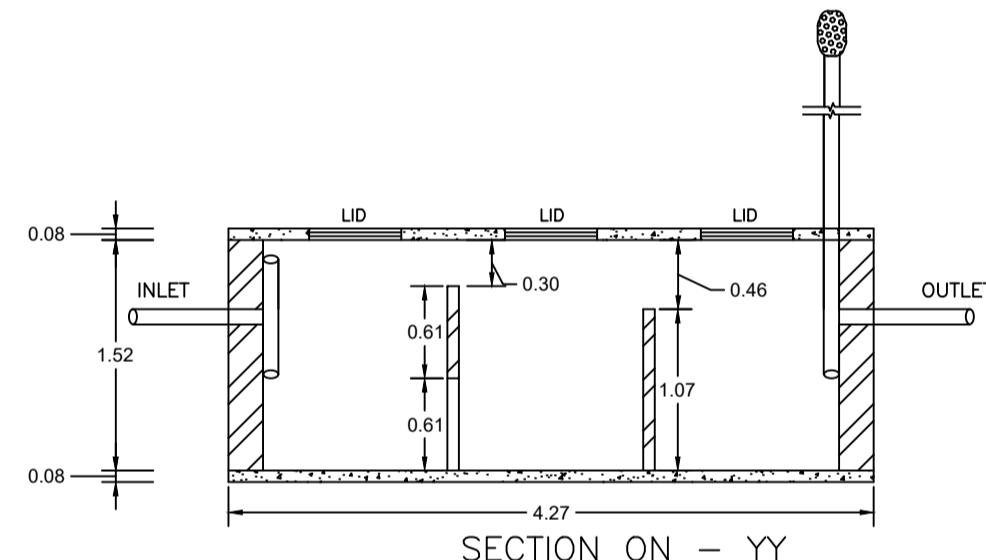

SECTION ON - YY
SCALE - 1:50

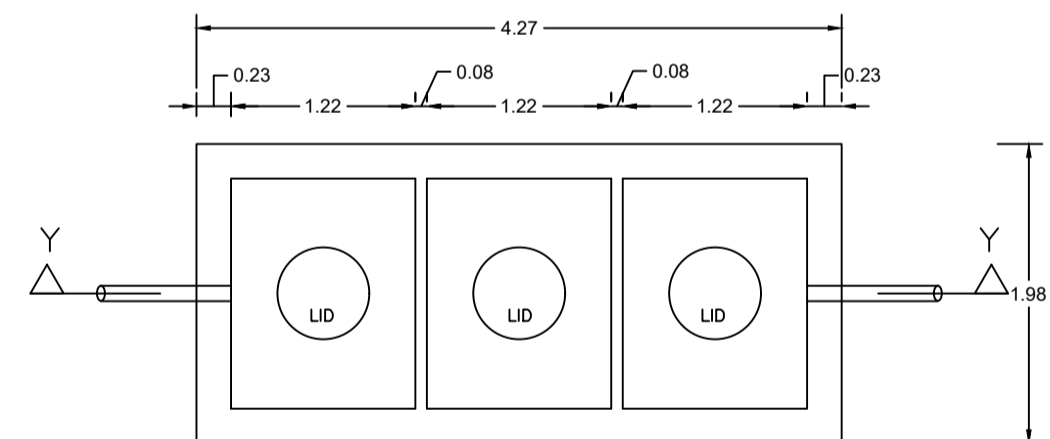

DETAILS OF SEPTIC TANK
SCALE - 1:50

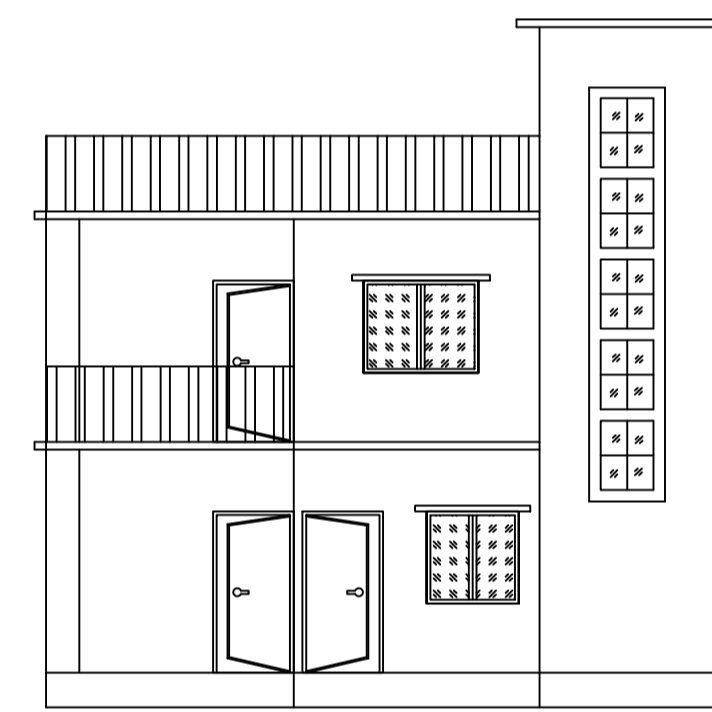

FRONT ELEVATION
SCALE - 1:100

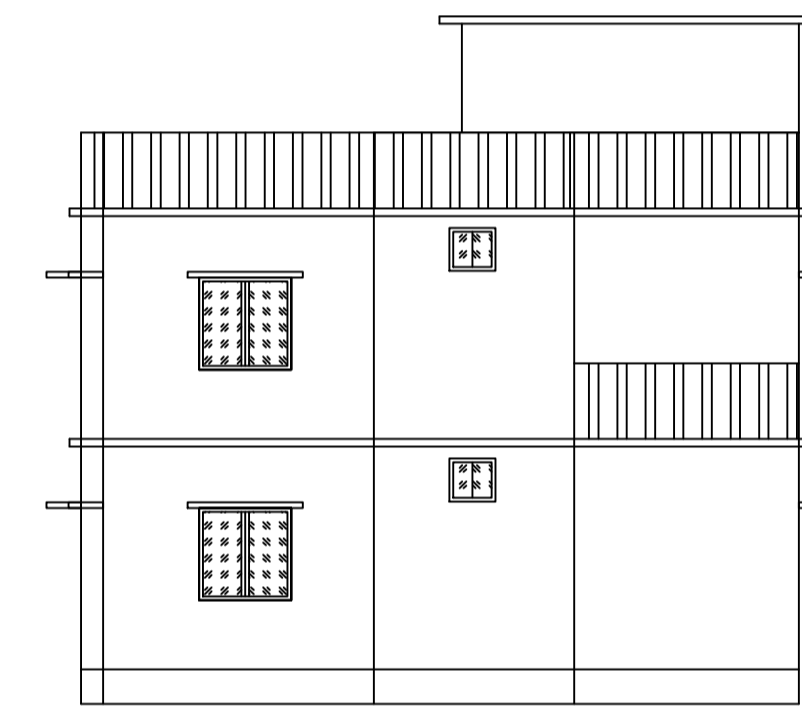

LEFT SIDE ELEVATION
SCALE - 1:100

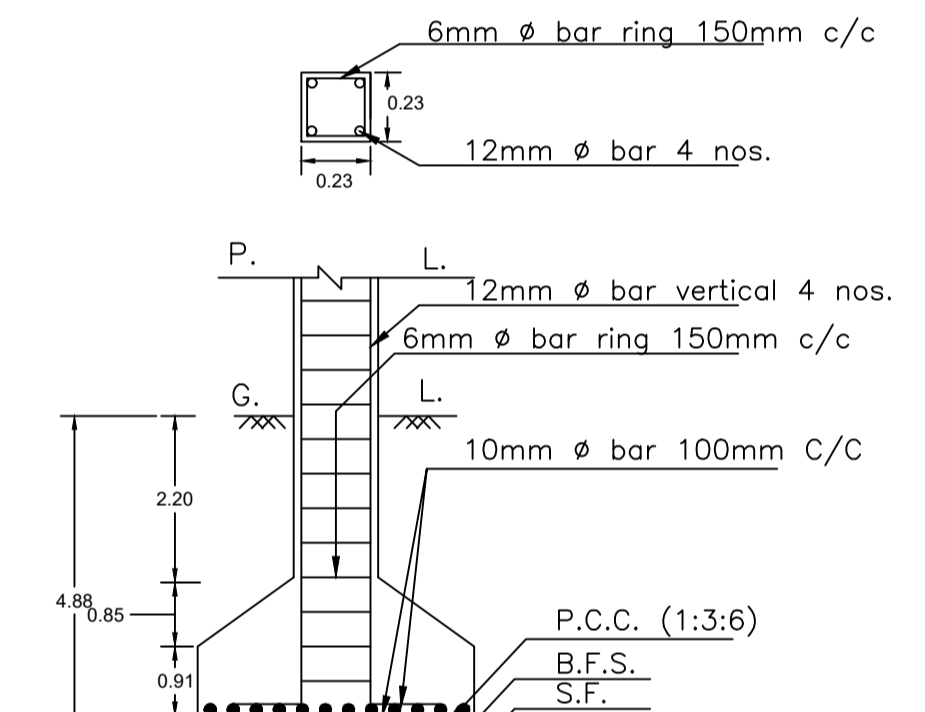

SECTION ON- ZZ
SCALE - 1:25

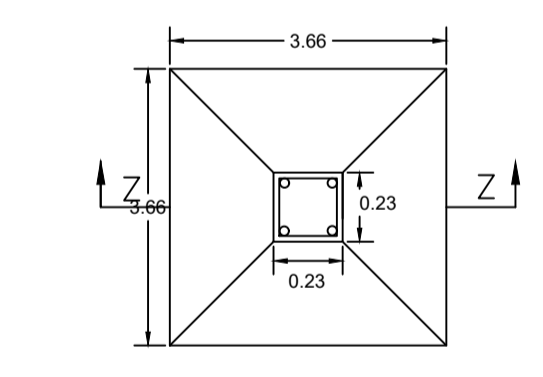

PLAN
DETAILS OF COLUMN FOOTING
SCALE - 1:25

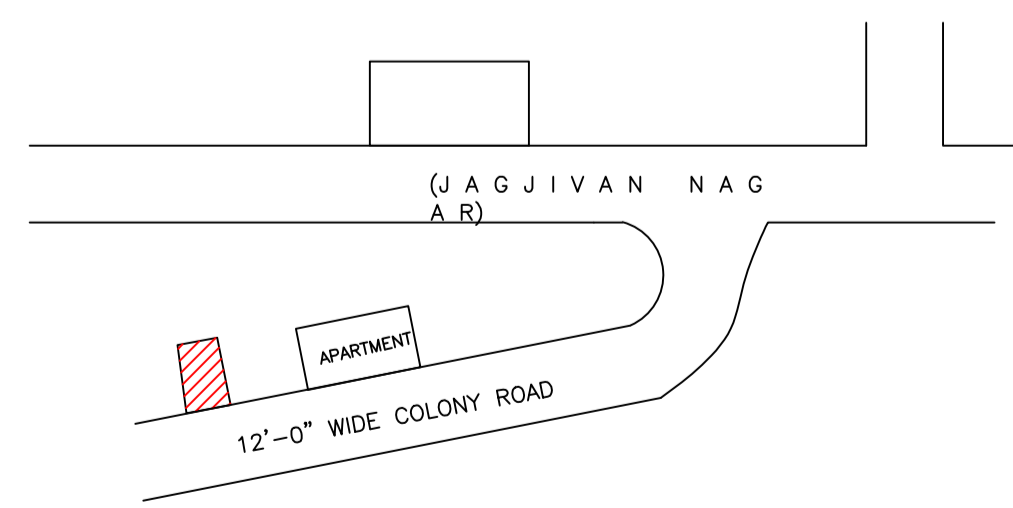

LOCATION

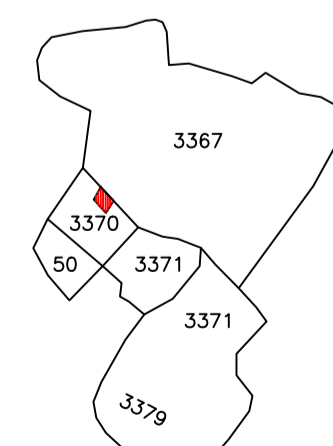

KEY PLAN
SCALE - NTS

LTP NAME AND SIGNATURE	STRUCTURAL ENG'S NAME AND SIGNATURE	BUILDER NAME AND SIGNATURE	DIGITAL SIGNATURE
SANJEEV KUMAR RAY DMC/ENG/0001/2019			