

Proposal Basic Information	
Proposal File No.	DMC/EP/0394/W33/2022
Owner Name	SRI DHARMENDRA KUMAR SINGH
Khata No	91
Plot No	549, 550
Village Name	Dhanbad
Use	Residential
SubUse	Bungalow/ Dwelling / Non Apartment

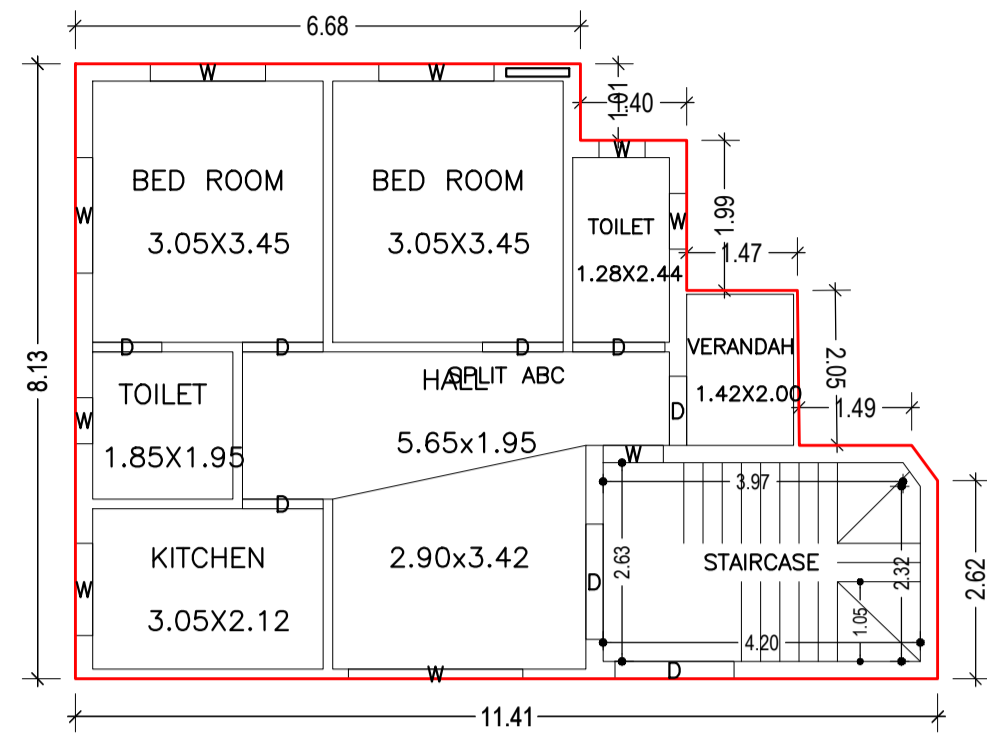

GROUND FLOOR PLAN
(Proposed)
(SCALE 1:100)

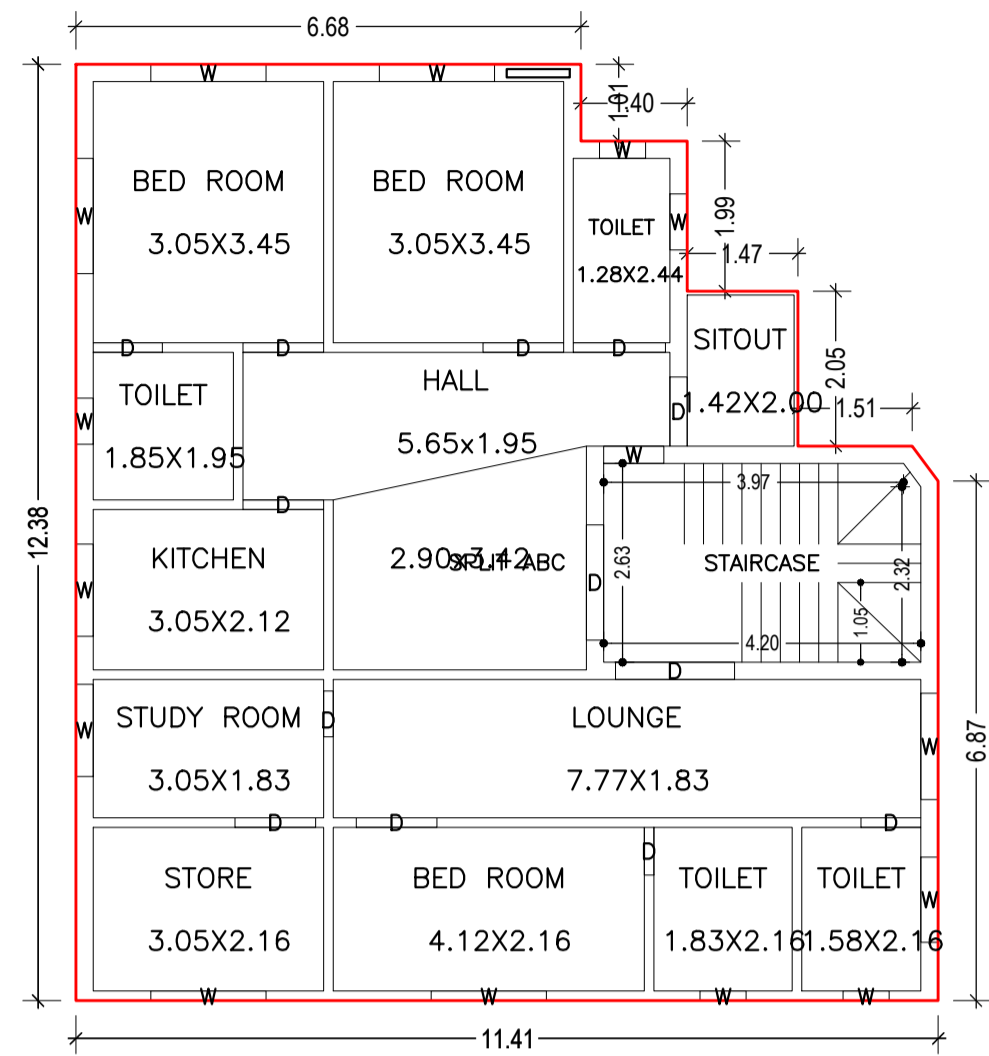

FIRST FLOOR PLAN
(Proposed)
(SCALE 1:100)

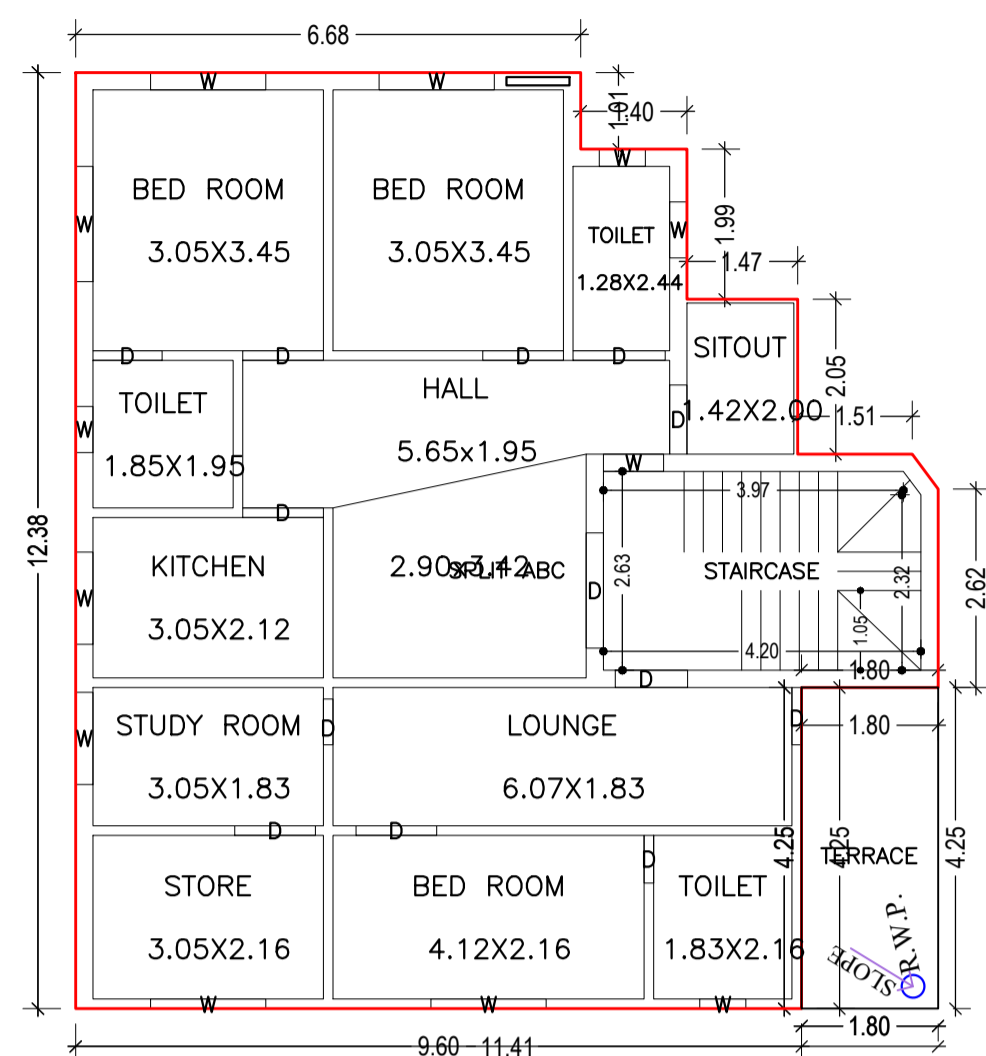

SECOND FLOOR PLAN
(Proposed)
(SCALE 1:100)

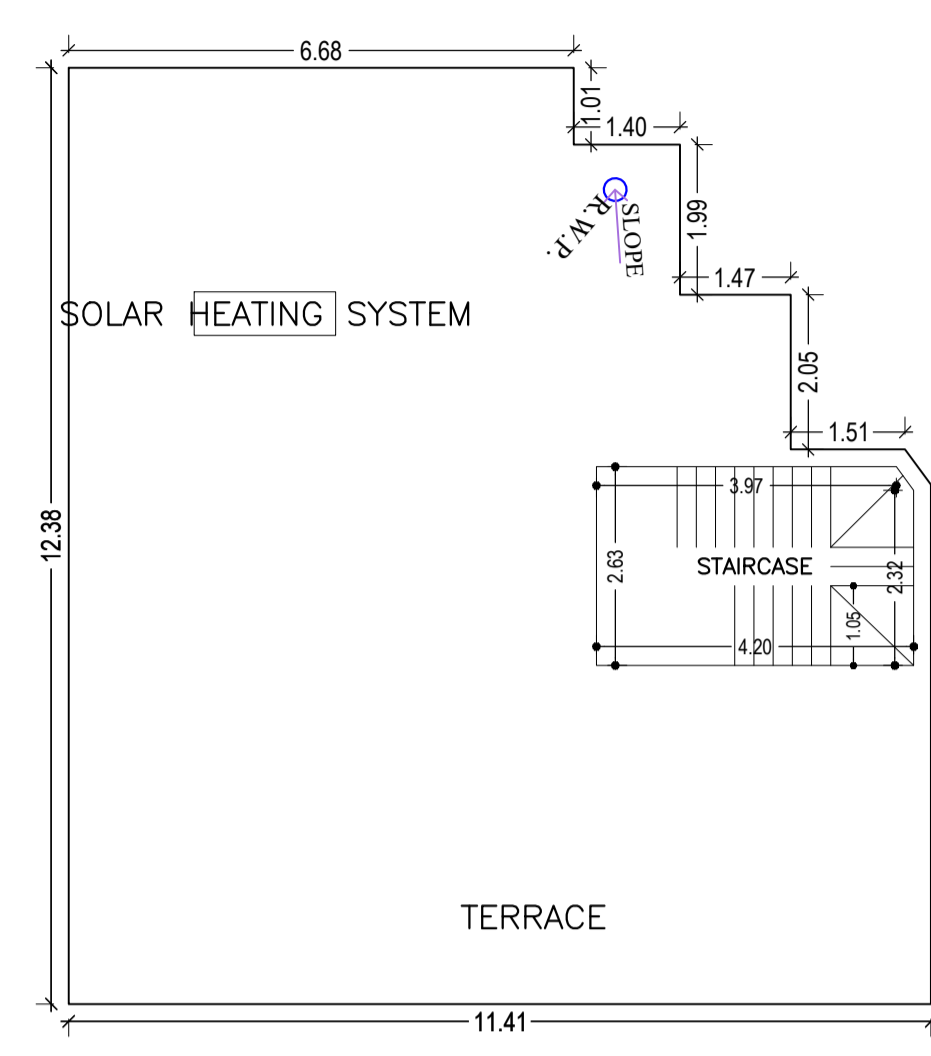

TERRACE FLOOR PLAN
(SCALE 1:100)

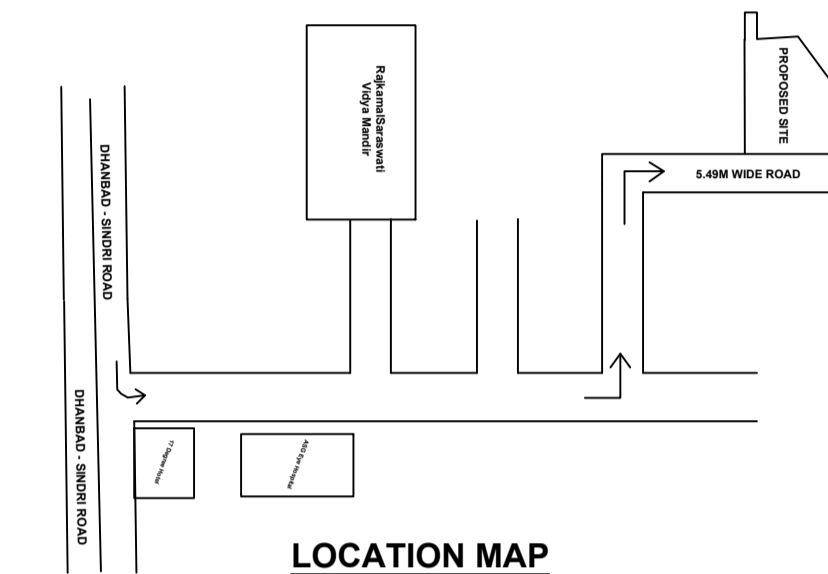

LOCATION MAP

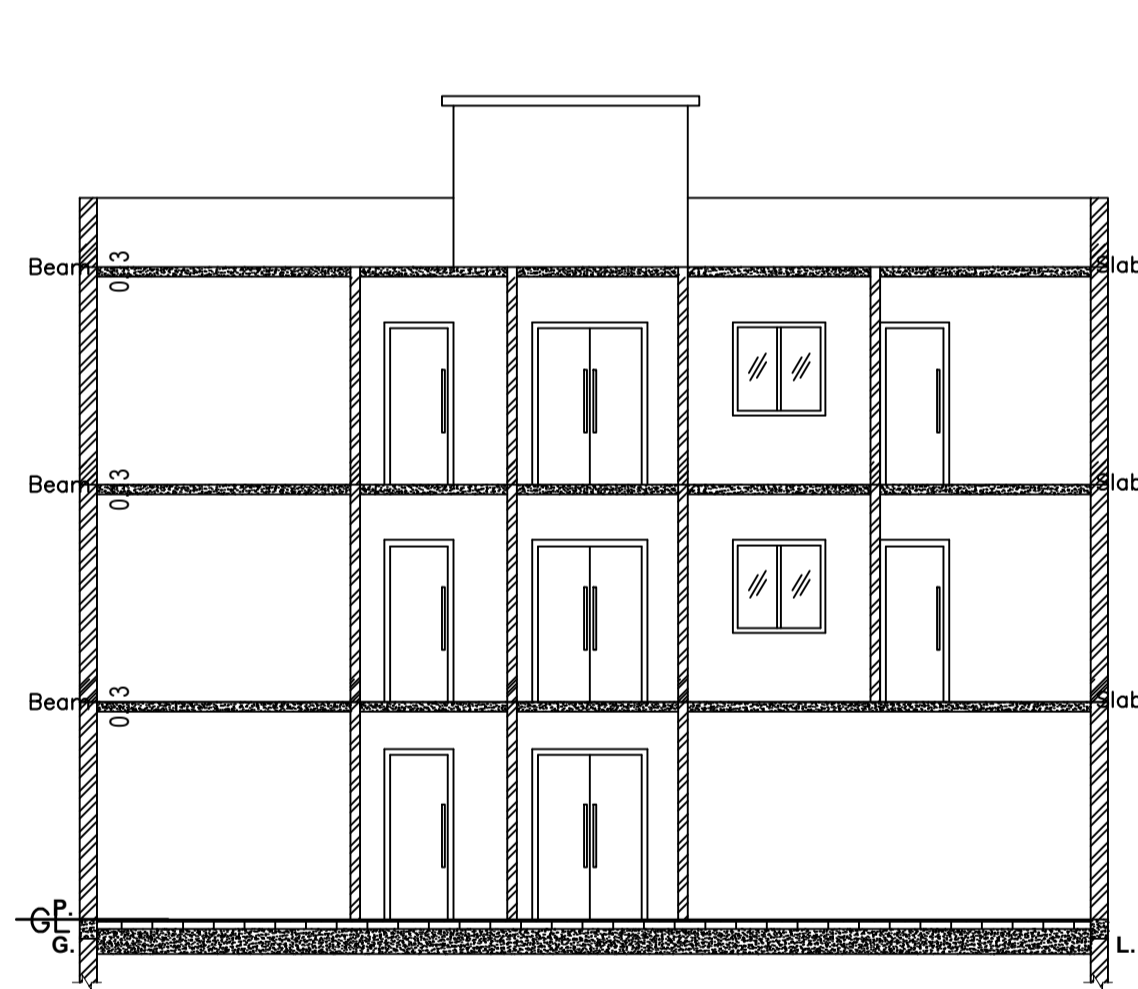

SECTION ON Y-Y

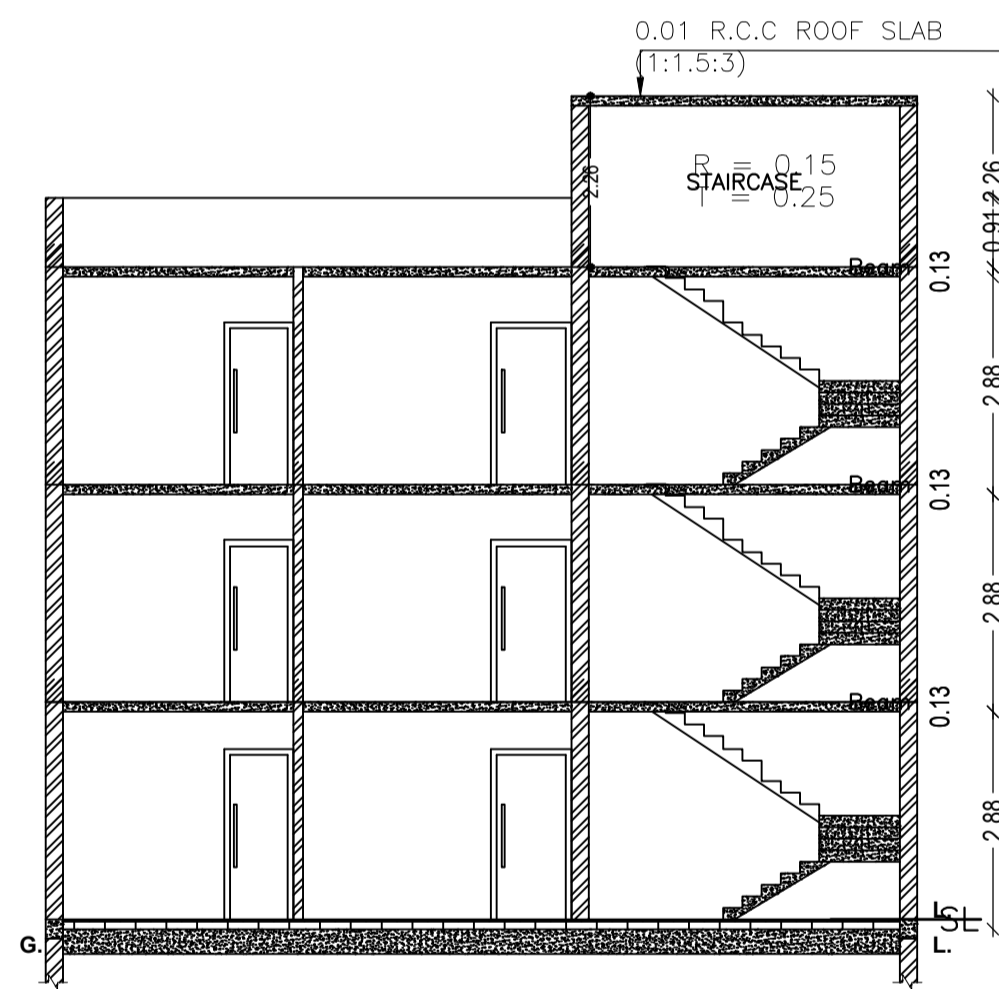

SECTION ON X-X

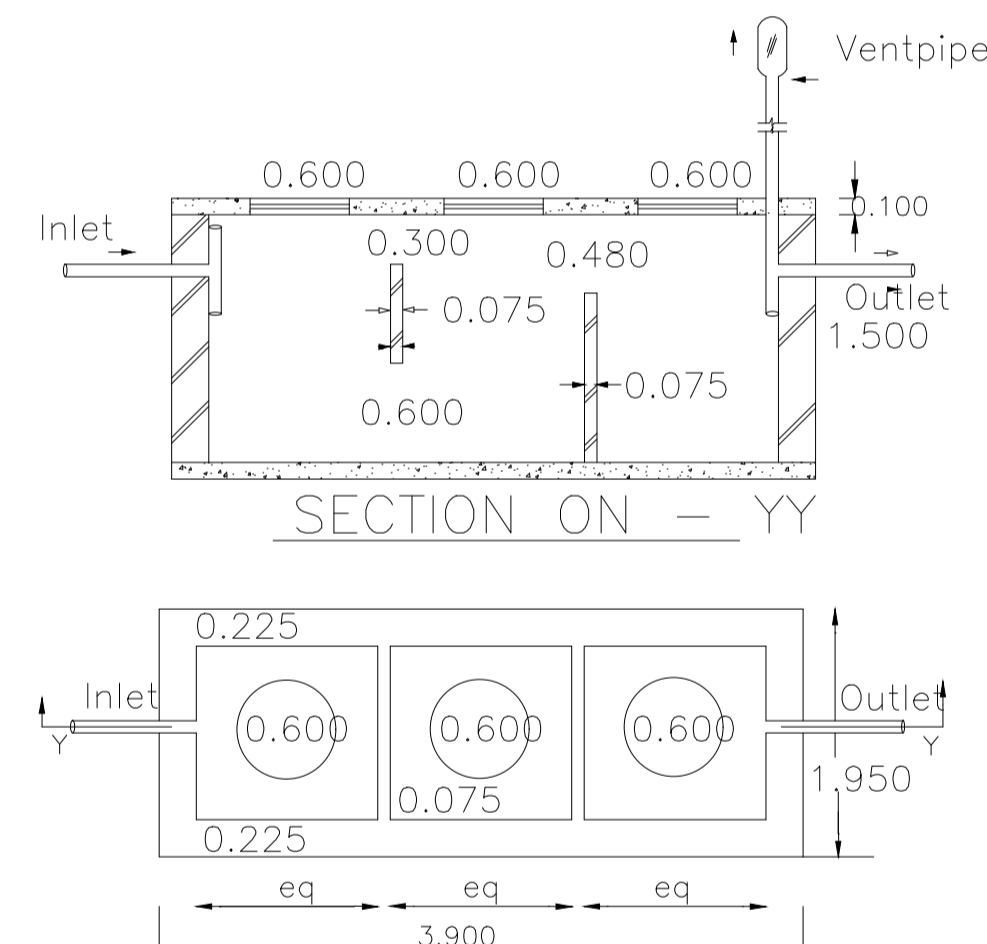

DETAILS OF SEPTIC TANK

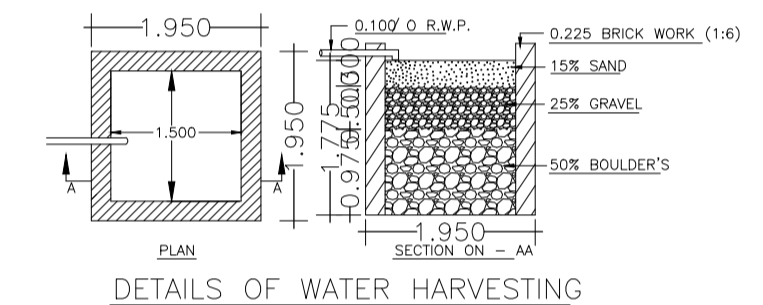

DETAILS OF WATER HARVESTING

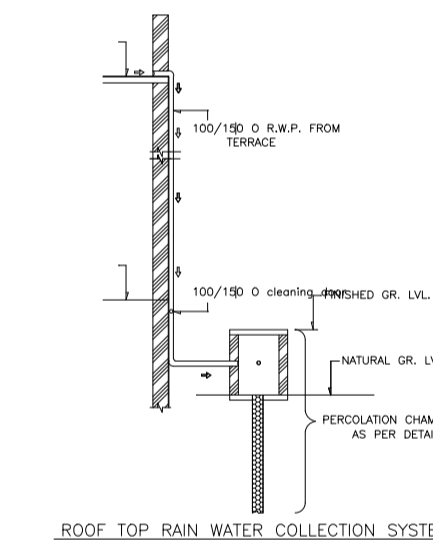

ROOF TOP RAIN WATER COLLECTION SYSTEM

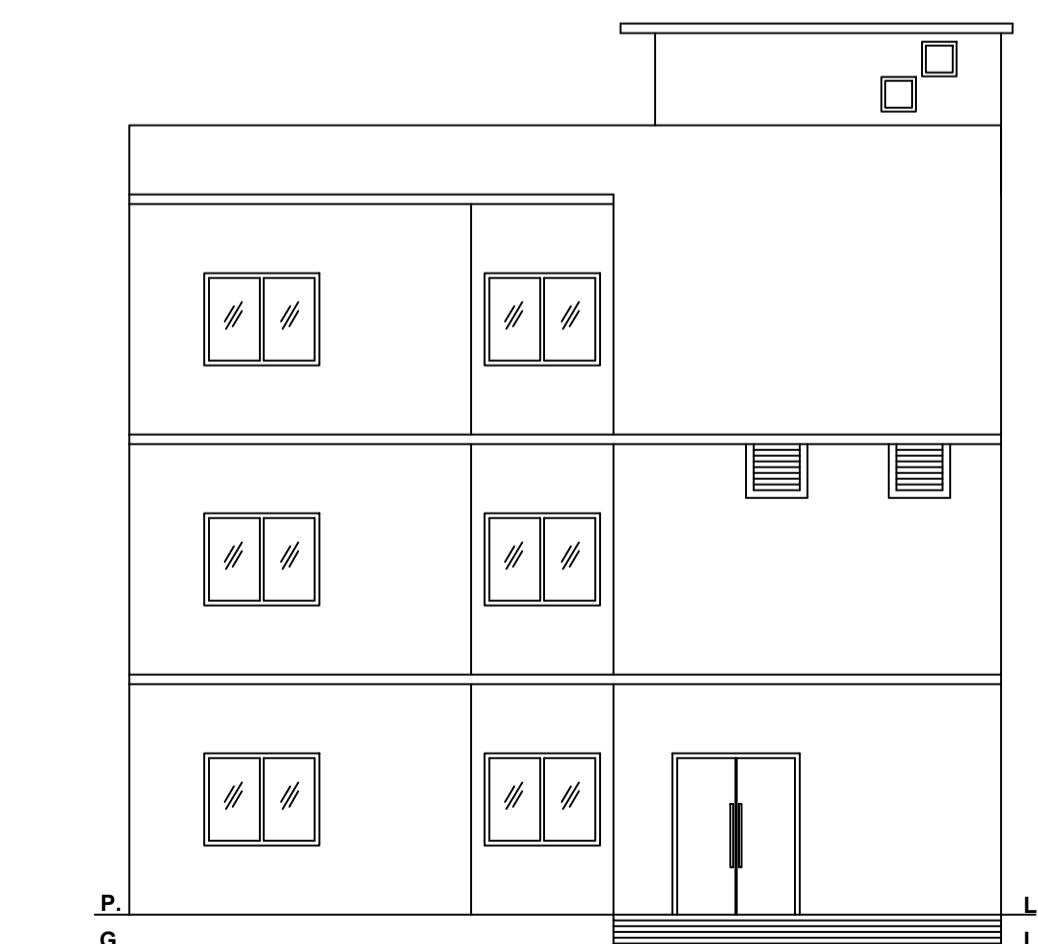

FRONT ELEVATION

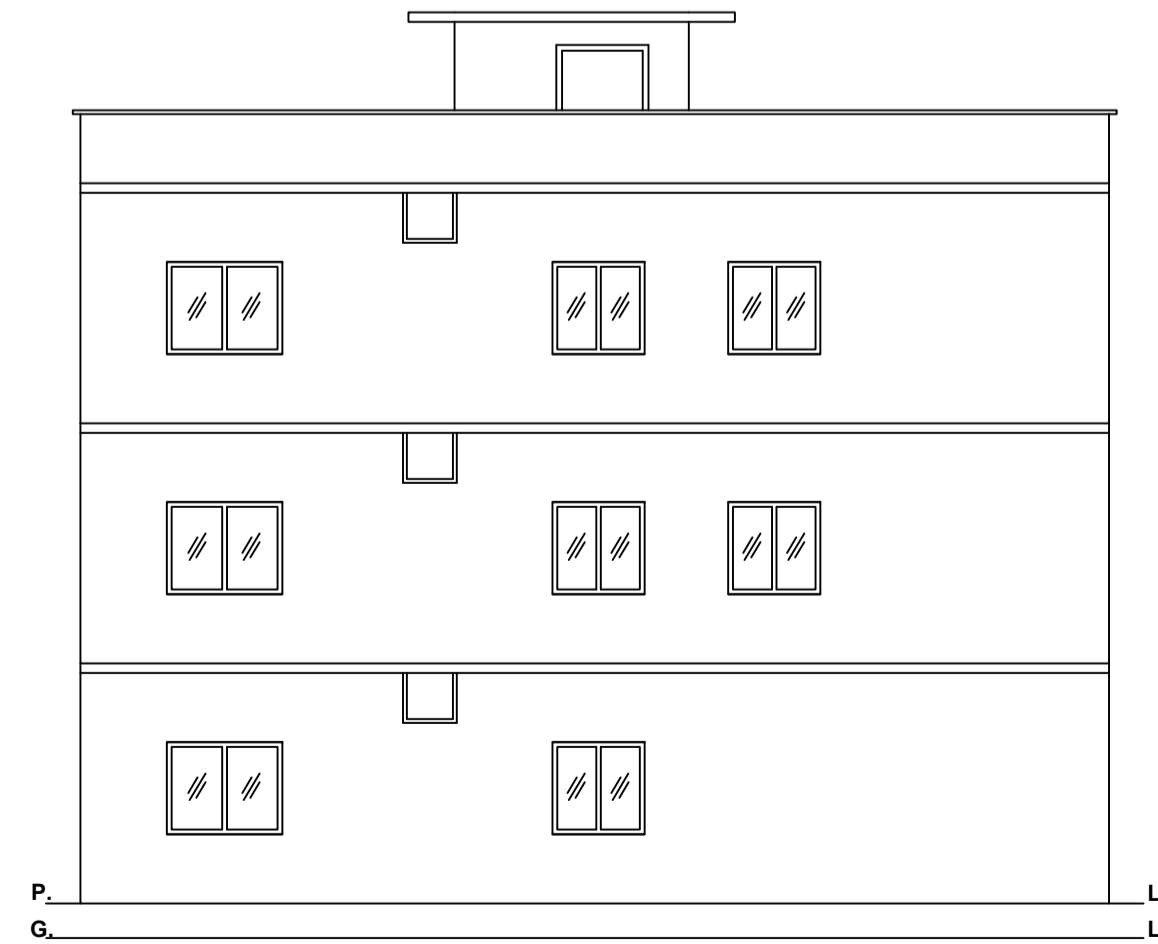

LEFT SIDE ELEVATION

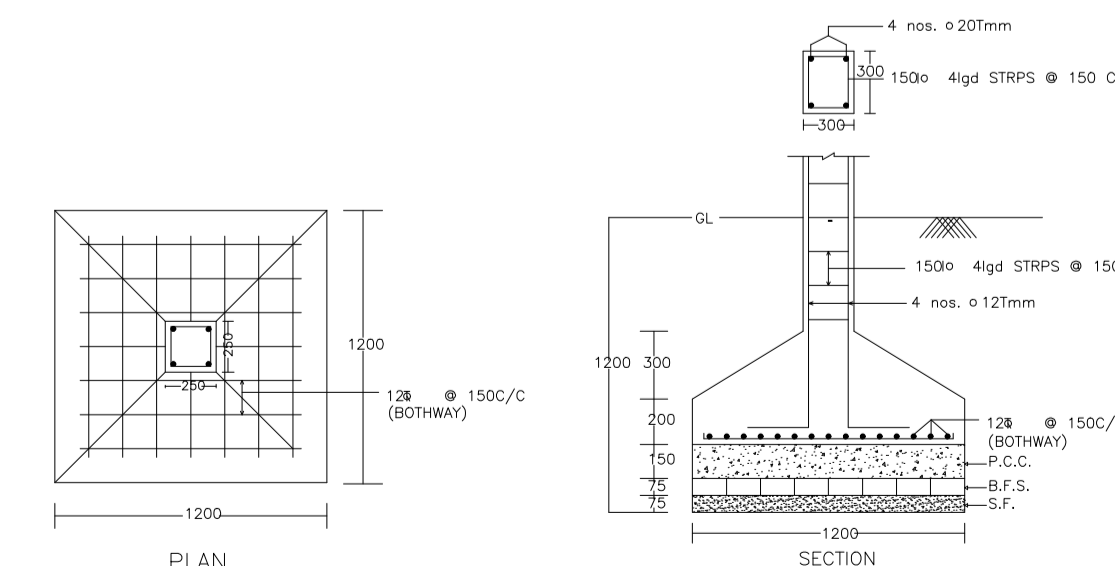

DETAIL OF COLUMNS

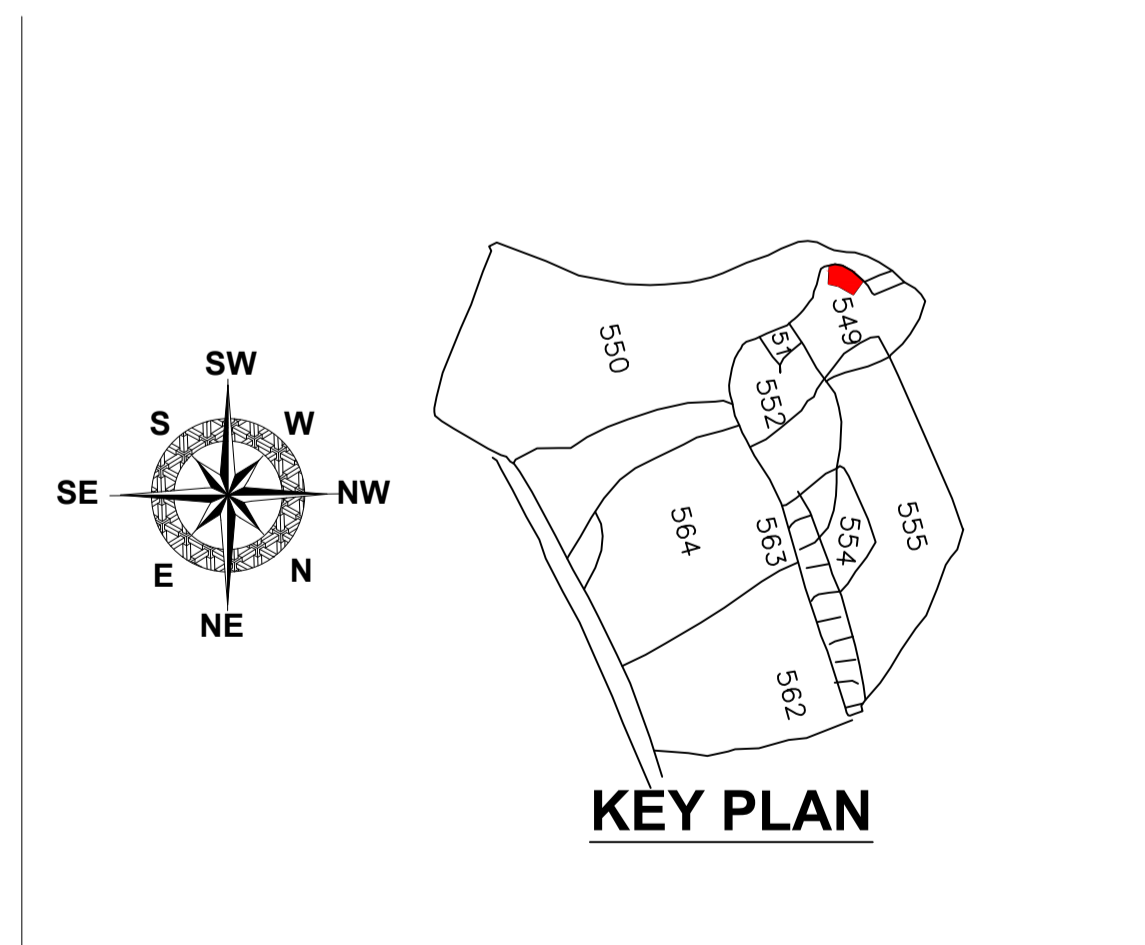

KEY PLAN

LTP NAME AND SIGNATURE	STRUCTURAL ENG'S NAME AND SIGNATURE	BUILDER NAME AND SIGNATURE	DIGITAL SIGNATURE
AJAY KUMAR DMC/ENG/0005/2022			