

Proposal Basic Information	
Proposal File No.	DMC/BI/0402/W21/2022
Owner Name	SMT. CHAMELI DEVI
Khata No	OLD-34 NEW-23
Plot No	OLD-402, NEW-223
Village Name	Baramuri
Use	Residential
SubUse	Bungalow/ Dwelling / Non Apartment

AREA STATEMENT		VERSION NO.:	1.0.65
DHANBAD MUNICIPAL CORPORATION		VERSION DATE: 16/10/2020	
PROJECT DETAIL:			
Region: JHARKHAND URBAN LOCAL BODIES	Plot Use: Residential		
District: DHANBAD	Plot SubUse: Bungalow/ Dwelling / Non Apartment		
Authority: DHANBAD MUNICIPAL CORPORATION	PlotNearby/ReligiousStructure: NA		
Inward No: DMC/BI/0402/W21/2022	Plot/SubPlot No: OLD-402, NEW-223		
Application Type: General Proposal	North: Plot No. - LAXMI DEVI		
Project Type: Building Permission	South: Plot No. - PART OF THIS PLOT		
Nature of Development: New	East: Road Width - 3.65		
Location of Development Area: Old Area	West: Road Width - 3.65		
AREA DETAILS:		SQ.MT.	
AREA OF PLOT (Minimum)	(A)	179.81	
Deduction for NetPlot Area			
Surrender Free of Cost		5.72	
Total		5.72	
NET AREA OF PLOT(Gross Plot Area - Deduction from Gross Plot area)		174.10	
Deduction for Balance Plot Area(from Gross Plot Area)			
Surrender Free of Cost		5.72	
Common Plot		10.13	
Total		15.85	
BALANCE AREA OF PLOT(Net Plot Area - Recreational/Amenity space)		(A-Deductions)	163.96
PLOT AREA FOR COVERAGE(Net Plot Area)		(A-Deductions)	174.10
Plot Area for FAR (Net Plot Area + RoadWidening Area)		(A-Deductions)	179.81
COVERAGE CHECK			
Permissible Coverage area (70.00 %)		121.87	
Proposed Coverage Area (69.47 %)		120.95	
Total Prop. Coverage Area (69.47 %)		120.95	
Balance coverage area (0.53 %)		0.92	
FAR CHECK			
Perm. FAR Area (1.500)		269.71	
Total Perm. FAR area		269.71	
Residential FAR		241.91	
Proposed FAR Area		241.91	
Total Proposed FAR Area		241.91	
Consumed FAR (Factor)		1.35	
Balance FAR Area		27.80	
BUILT UP AREA CHECK			
Total Proposed BuiltUp Area		241.90	
ARCHITECT (Regd)		RAJEEV RANJAN SINGH	
ENGINEER (Regd)			
SUPERVISOR (Regd)			
OWNER (Regd)		SMT. CHAMELI DEVI	
DEVELOPMENT AUTHORITY		LOCAL BODY	

UnitBUA Table for Building :A (A)

FLOOR	Name	UnitBUA Type	UnitBUA Area	Carpet Area	No. of Rooms	No. of Tenement
GROUND FLOOR PLAN	SPLIT A	FLAT	241.91	241.84	9	1
FIRST FLOOR PLAN	SPLIT A	FLAT	0.00	0.00	9	0
PLAN	-	-	241.91	241.84	18	1

SCHEDULE OF DOOR:

BUILDING NAME	NAME	LENGTH	HEIGHT	NOS
A (A)	D	0.76	2.10	06
A (A)	D	1.07	2.10	04
A (A)	D	1.10	2.10	02
A (A)	D	1.30	2.10	02

SCHEDULE OF WINDOW/VENTILATION:

BUILDING NAME	NAME	LENGTH	HEIGHT	NOS
A (A)	V	0.61	1.20	04
A (A)	W	1.22	1.20	02
A (A)	W	1.52	1.20	08
A (A)	W	2.25	1.20	02
A (A)	W	2.41	1.20	08

Building :A (A)

Floor Name	Total Built Up Area (Sq.mt.)	Proposed FAR Area (Sq.mt.)	Total FAR Area (Sq.mt.)	Total Consumed Additional FAR Area (Sq.mt.)	Tnmt (No.)
Ground Floor	120.95	120.95	120.95	120.95	01
First Floor	120.95	120.95	120.95	120.95	00
Terrace Floor	0.00	0.00	0.00	0.00	00
Total :	241.90	241.90	241.90	241.90	01
Total Number of Same Buildings :	1				
Total :	241.90	241.90	241.90	241.90	01

FAR & Tenement Details (Table 4c-1)

Building	No. of Same Bldg	Total Built Up Area (Sq.mt.)	Proposed FAR Area (Sq.mt.)	Total FAR Area (Sq.mt.)	Total Consumed Additional FAR Area (Sq.mt.)	Tnmt (No.)
A (A)	1	241.90	241.90	241.90	241.90	01
Grand Total :	1	241.90	241.90	241.90	241.90	01

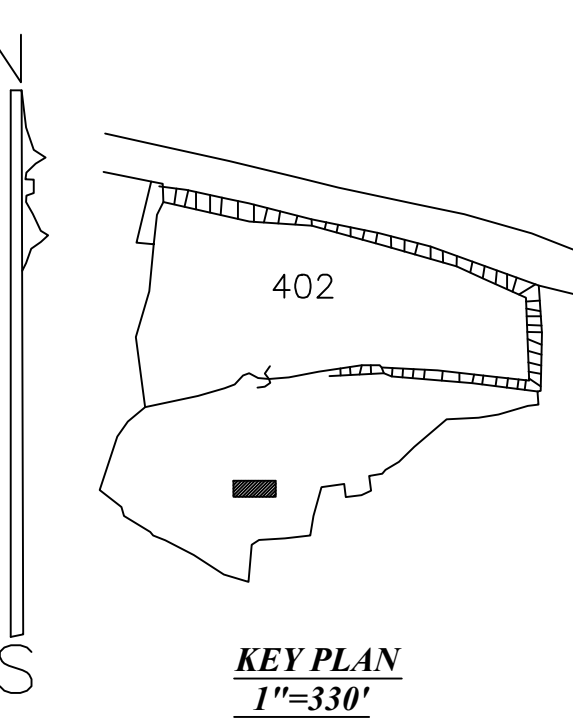
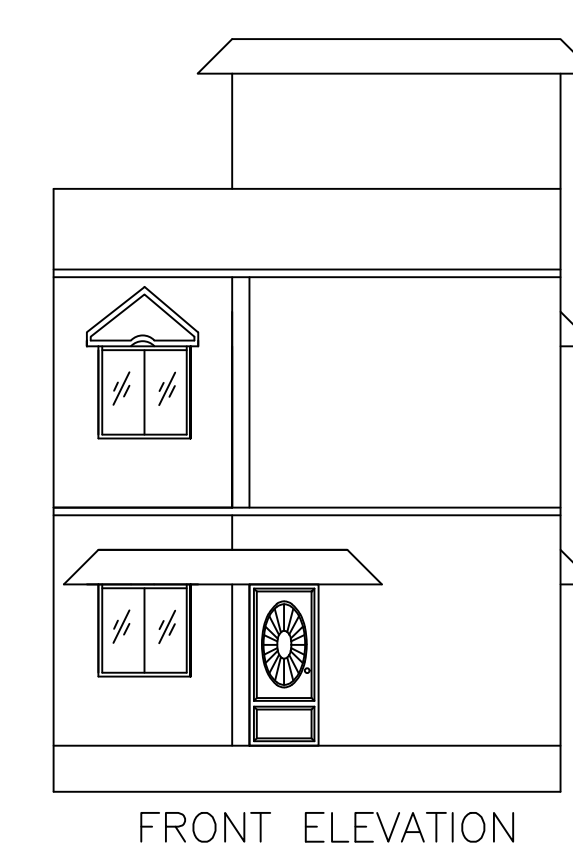
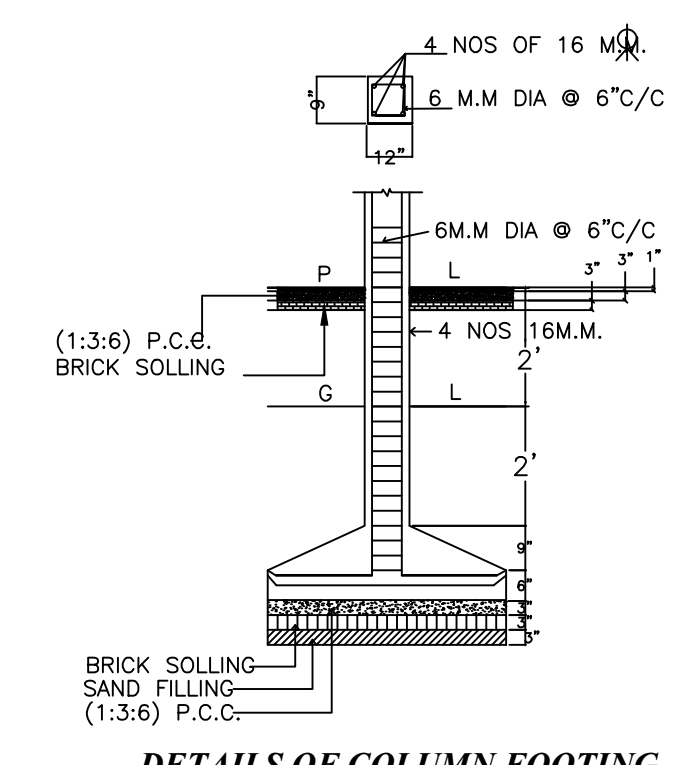
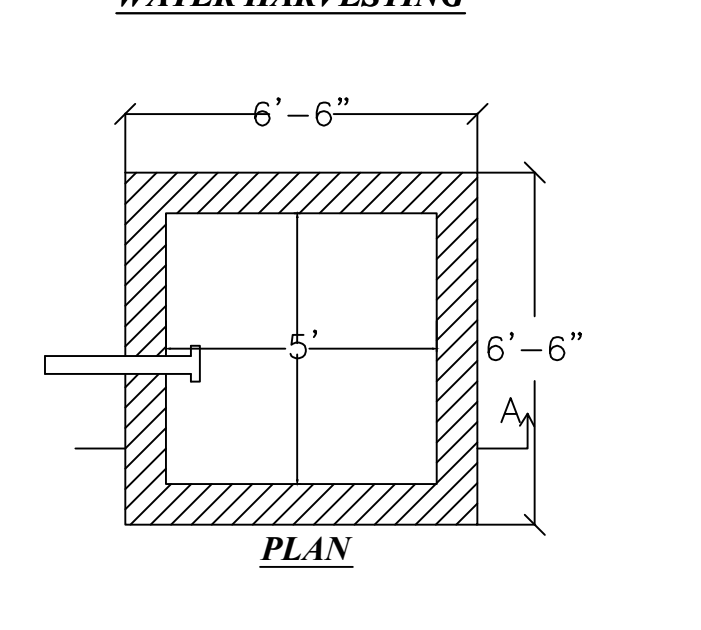
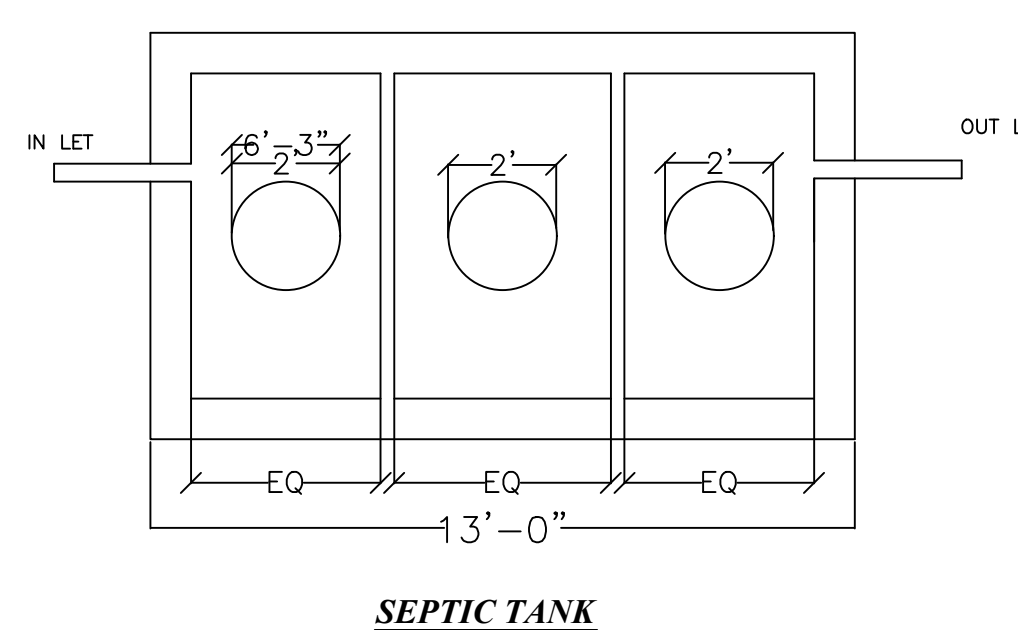
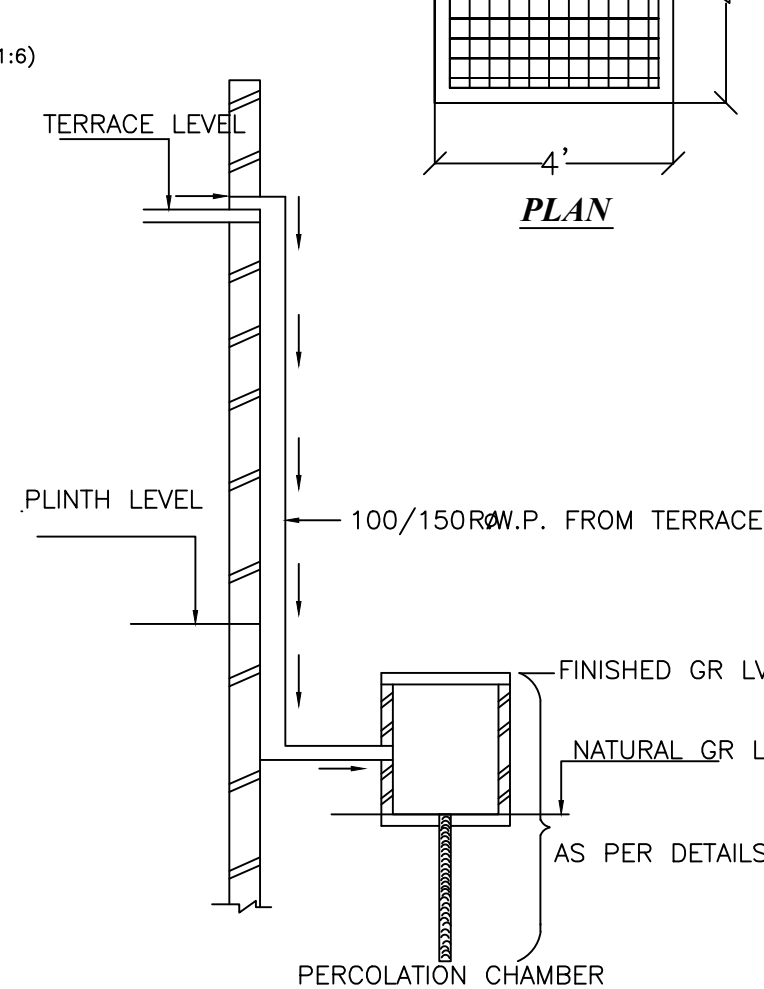
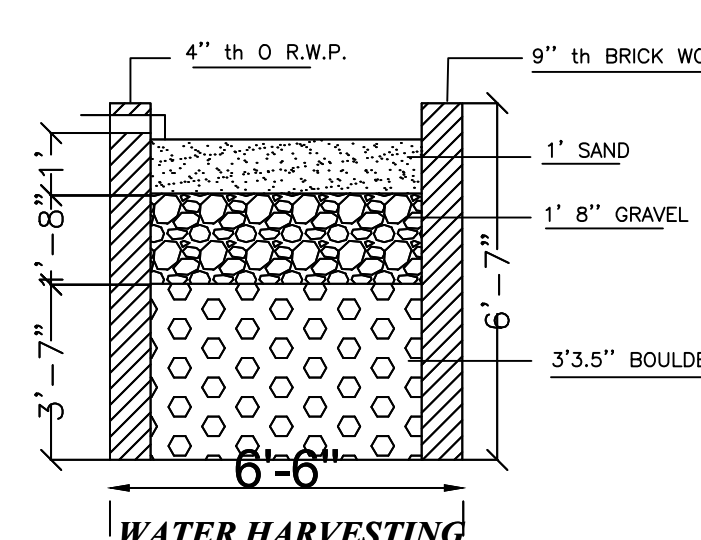
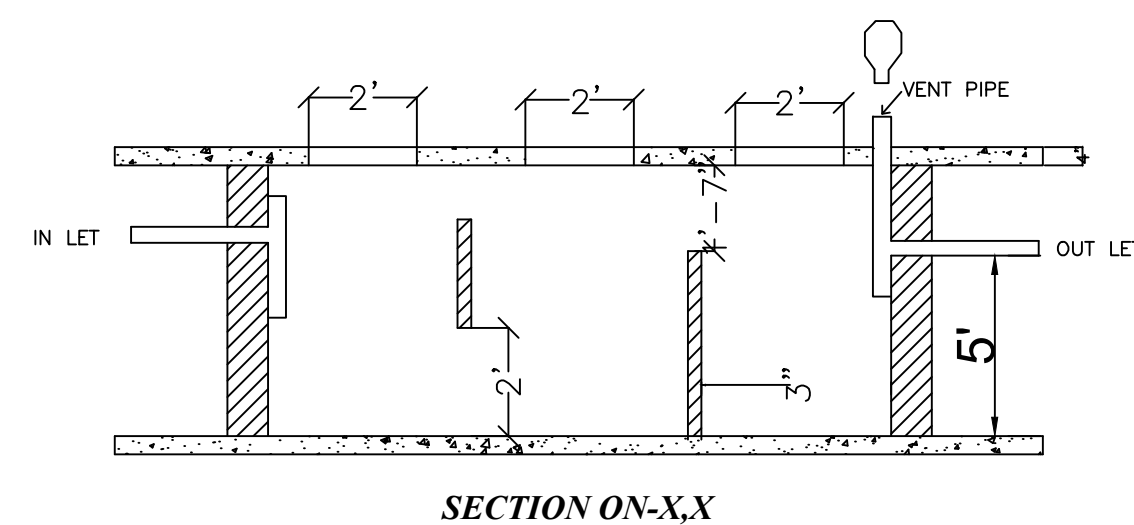

COLOR INDEX	
PLOT BOUNDARY	Black
ABUTTING ROAD	Red
PROPOSED CONSTRUCTION	Green
COMMON PLOT	Yellow
ROAD WIDENING AREA	Orange
EXISTING (To be retained)	Blue
EXISTING (To be demolished)	Light Blue

Buildingwise Floor FAR Details

Floor Name	Building Name A (A)		Total	
	Proposed Built Up Area (Sq.mt.)	Proposed FAR Area (Sq.mt.)	Total Proposed Built Up Area (Sq.mt.)	Total FAR Area (Sq.mt.)
Ground Floor	120.95	120.95	120.95	120.95
First Floor	120.95	120.95	120.95	120.95
Terrace Floor	0.00	0.00	0.00	0.00
Total :	241.90	241.90	241.90	241.90

Building USE/SUBUSE Details

Building Name	Building Use	Building SubUse	Building Structure
A (A)	Residential	Bungalow/ Dwelling / Non Apartment	Non-Highrise

LTP NAME AND SIGNATURE	STRUCTURAL ENG'S NAME AND SIGNATURE	BUILDER NAME AND SIGNATURE	DIGITAL SIGNATURE
RAJEEV RANJAN SINGH DMC/ENG/0032/2017			