

Proposal Basic Information

Proposal File No.	DMC/BP/0355/W25/2022
Owner Name	MUNNA BANSFORE
Khata No	78
Plot No	1718
Village Name	Hirapur
Use	Residential
SubUse	Bungalow/ Dwelling / Non Apartment

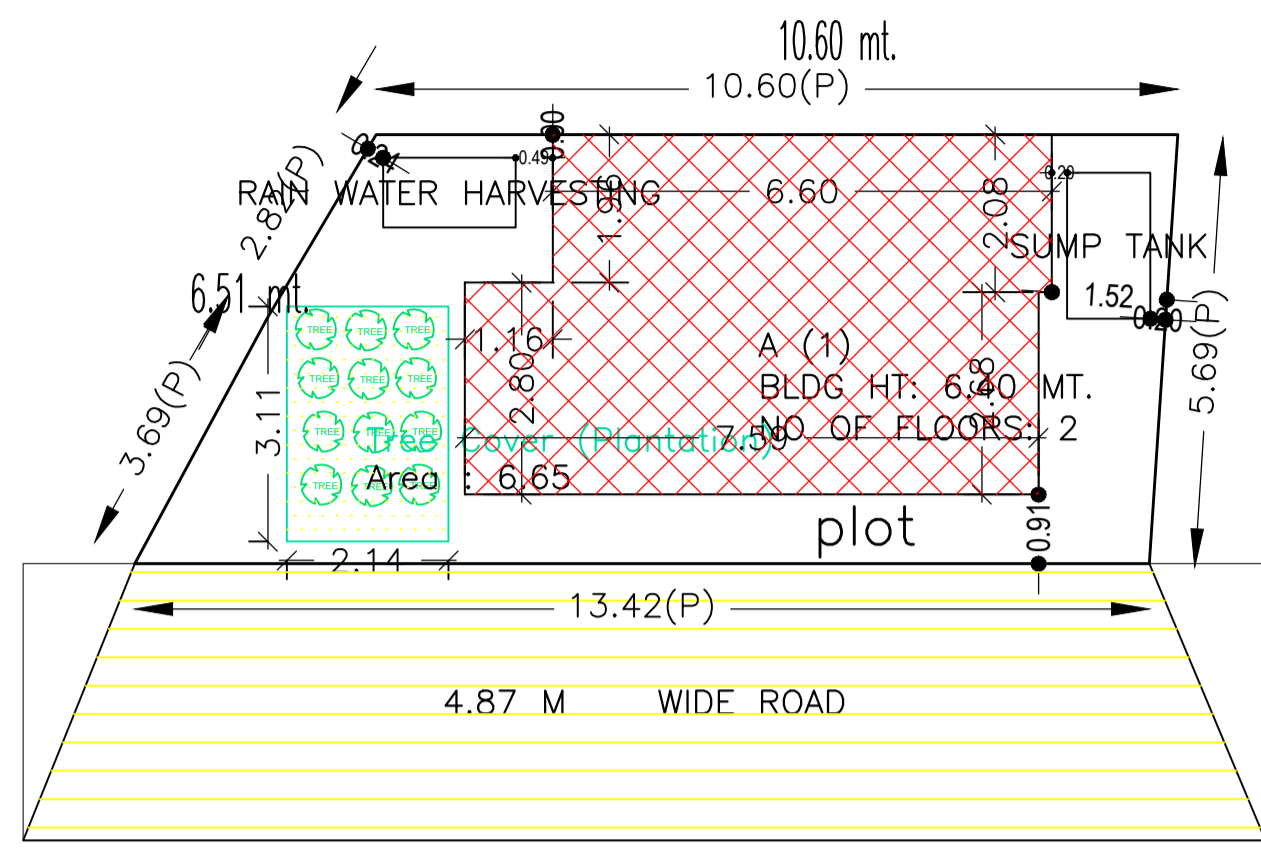

site plan

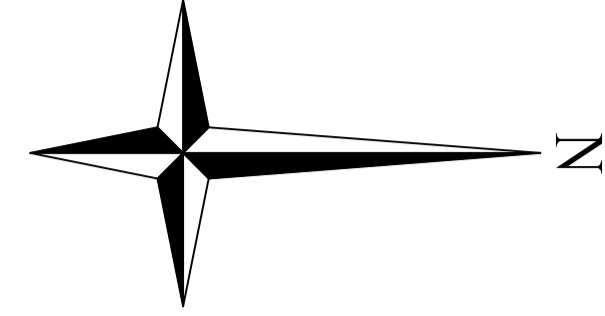
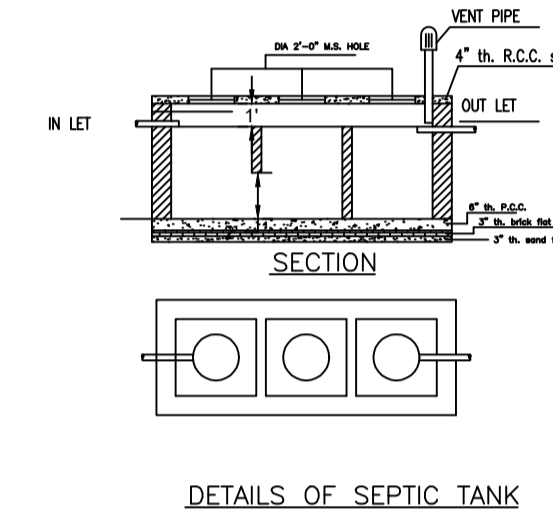
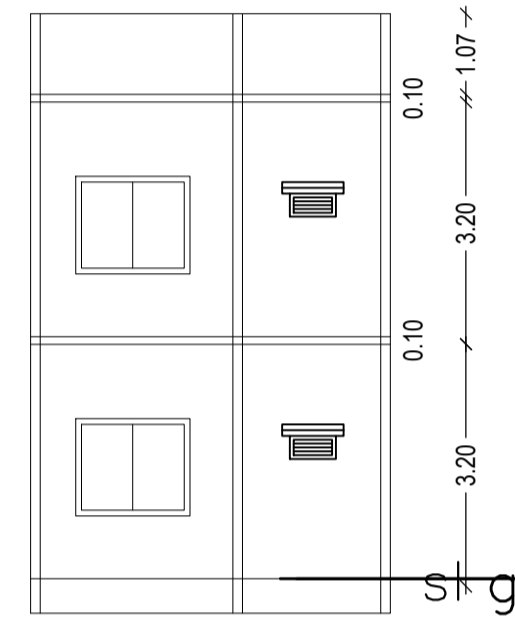
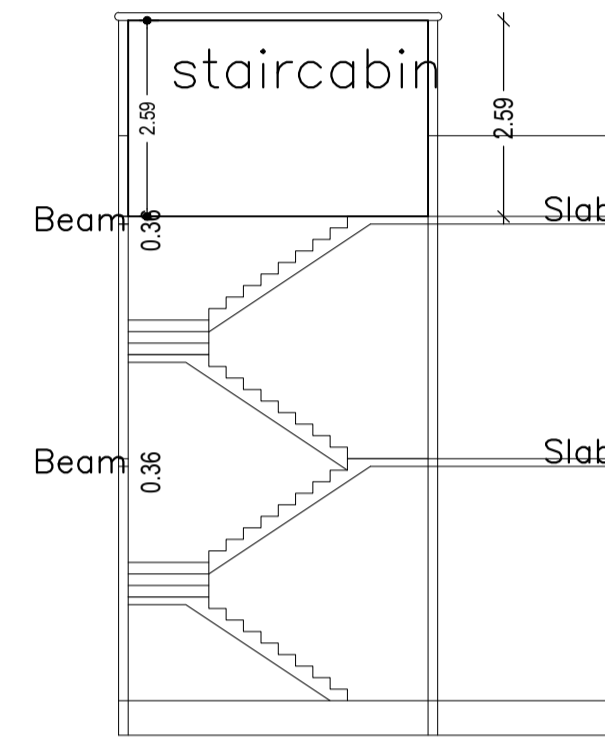
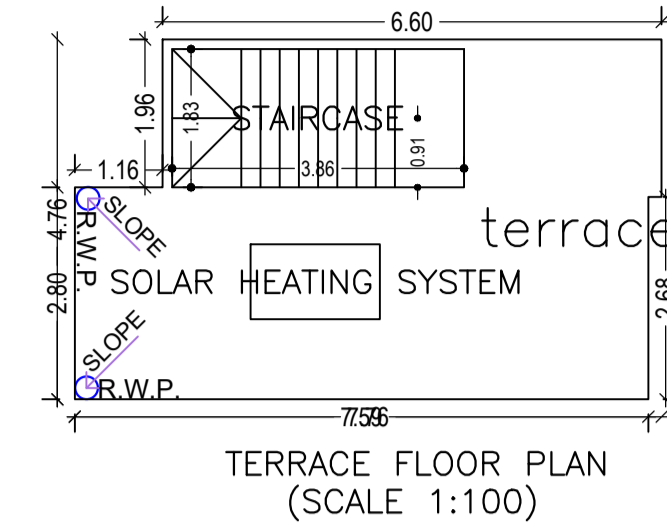
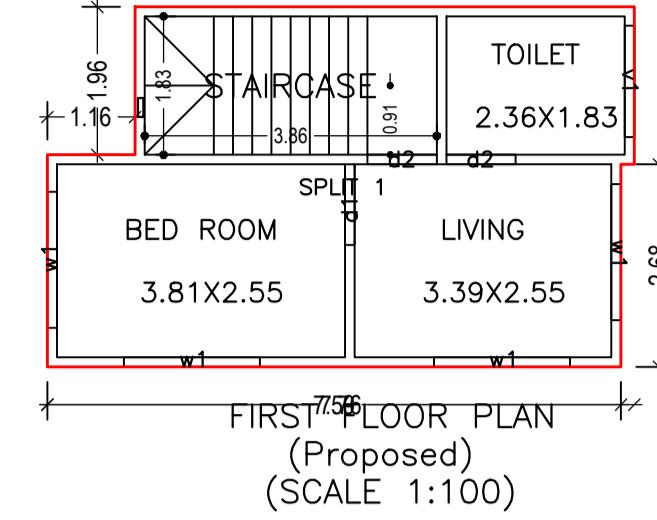
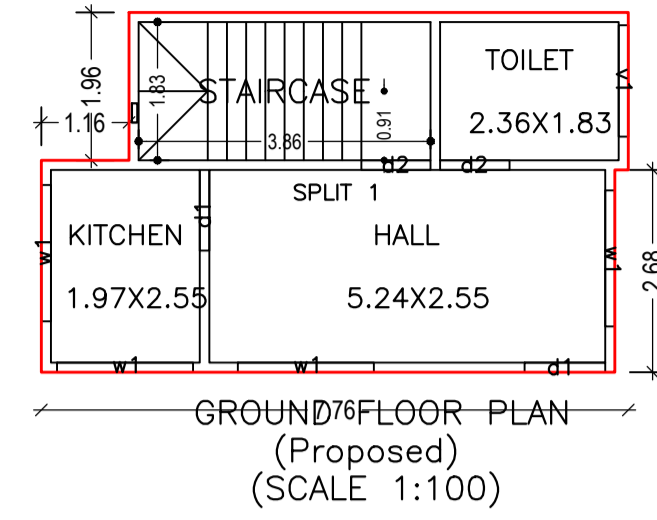

DETAILS OF SEPTIC TANK

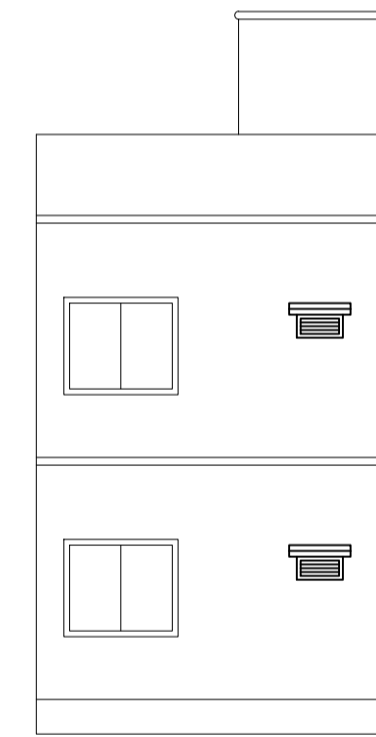
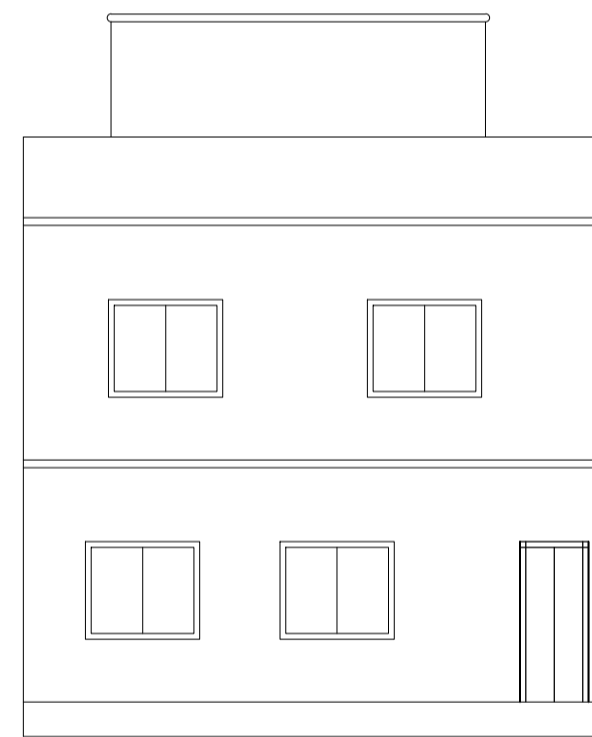

AREA STATEMENT DHANBAD MUNICIPAL CORPORATION	VERSION NO. : 1.0.64 VERSION DATE: 16/10/2020	
PROJECT DETAIL:		
Region - JHARKHAND URBAN LOCAL BODIES	Plot Use: Residential	
District: DHANBAD	Plot SubUse: Bungalow/ Dwelling / Non Apartment	
Authority: DHANBAD MUNICIPAL CORPORATION	PlotNearby/ReligiousStructure: NA	
Inward No: DMC/BP/0355/W25/2022	Plot/SubPlot No: 1718	
Application Type: General Proposal	North: Plot No. - 1718 (P)	
Project Type: Building Permission	South: Plot No. - 1680	
Nature of Development: New	East: Road Width - 5.18	
Location of Development Area: Old Area	West: Plot No. - 1604, 1680 (P)	
AREA DETAILS:		
AREA OF PLOT (Minimum)	(A)	68.38
NET AREA OF PLOT (Gross Plot Area - Deduction from Gross Plot area)	(A-Deductions)	68.38
Deduction for Balance Plot Area (from Gross Plot Area)		
Common Plot		6.65
Total		6.65
BALANCE AREA OF PLOT (Net Plot Area - Recreational/Amenity space)	(A-Deductions)	61.73
PLOT AREA FOR COVERAGE (Net Plot Area)	(A-Deductions)	68.38
Plot Area for FAR (Net Plot Area + Road Widening Area)	(A-Deductions)	68.38
COVERAGE CHECK		
Permissible Coverage area (70.04 %)		47.87
Proposed Coverage Area (50.04 %)		34.22
Total Prop. Coverage Area (50.04 %)		34.22
Balance coverage area (19.96 %)		13.65
FAR CHECK		
Perm. FAR Area (1.800)		123.08
Total Perm. FAR area		123.08
Residential FAR		68.43
Proposed FAR Area		68.43
Total Proposed FAR Area		68.43
Consumed FAR (Factor)		1.00
Balance FAR Area		54.65
BUILT UP AREA CHECK		
Total Proposed BuiltUp Area		68.44
ARCHITECT (Regd)		SUSHIL KUMAR
ENGINEER (Regd)		
SUPERVISOR (Regd)		
OWNER (Regd)		MUNNA BANSFORE
DEVELOPMENT AUTHORITY		LOCAL BODY

COLOR INDEX	
PLOT BOUNDARY	Black
ABUTTING ROAD	Red
PROPOSED CONSTRUCTION	Green
COMMON PLOT	Yellow
ROAD WIDENING AREA	Blue
EXISTING (To be retained)	Orange
EXISTING (To be demolished)	Light Blue

Buildingwise Floor FAR Details

Floor Name	Building Name A (1)		Total	
	Proposed Built Up Area (Sq.mt.)	Proposed FAR Area (Sq.mt.)	Total Proposed Built Up Area (Sq.mt.)	Total FAR Area (Sq.mt.)
Ground Floor	34.22	34.22	34.22	34.22
First Floor	34.22	34.22	34.22	34.22
Terrace Floor	0.00	0.00	0.00	0.00
Total :	68.44	68.44	68.44	68.44

Building USE/SUBUSE Details

Building Name	Building Use	Building SubUse	Building Structure
A (1)	Residential	Bungalow/ Dwelling / Non Apartment	Non-Highrise

FAR & Tenement Details (Table 4c-1)

Building	No of Same Bldg	Total Built Up Area (Sq.mt.)	Proposed FAR Area (Sq.mt.)	Total FAR Area (Sq.mt.)	Total Consumed Additional FAR Area (Sq.mt.)	Trmt (No.)
A (1)	1	68.44	68.44	68.44	68.44	01
Grand Total :	1	68.44	68.44	68.44	68.44	01

UnitBUA Table for Building :A (1)

FLOOR	Name	UnitBUA Type	UnitBUA Area	Carpent Area	No. of Rooms	No. of Tenement
GROUND FLOOR PLAN	SPLIT 1	FLAT	68.43	68.40	3	1
FIRST FLOOR PLAN	SPLIT 1	FLAT	0.00	0.00	3	0
Total:	-	-	68.43	68.40	6	1

Building :A (1)

Floor Name	Total Built Up Area (Sq.mt.)	Proposed FAR Area (Sq.mt.)	Total FAR Area (Sq.mt.)	Total Consumed Additional FAR Area (Sq.mt.)	Trmt (No.)
Ground Floor	34.22	34.22	34.22	34.22	01
First Floor	34.22	34.22	34.22	34.22	00
Terrace Floor	0.00	0.00	0.00	0.00	00
Total :	68.44	68.44	68.44	68.44	01
Total Number of Same Buildings :	1				
Total :	68.44	68.44	68.44	68.44	01

SCHEDULE OF DOOR:

BUILDING NAME	NAME	LENGTH	HEIGHT	NOS
A (1)	d2	0.91	2.10	04
A (1)	d1	1.07	2.10	03

SCHEDULE OF WINDOW/VENTILATION:

BUILDING NAME	NAME	LENGTH	HEIGHT	NOS
A (1)	v1	1.48	0.30	02
A (1)	w1	1.80	1.20	08

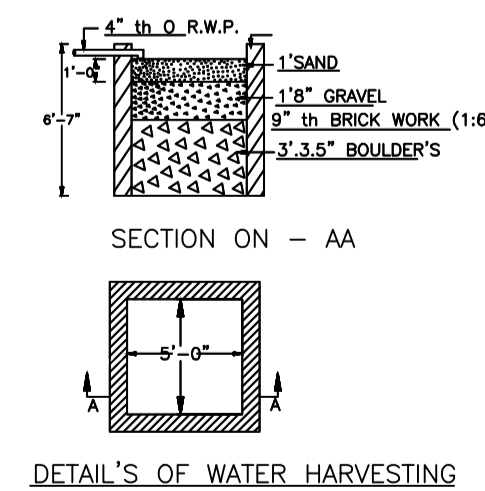
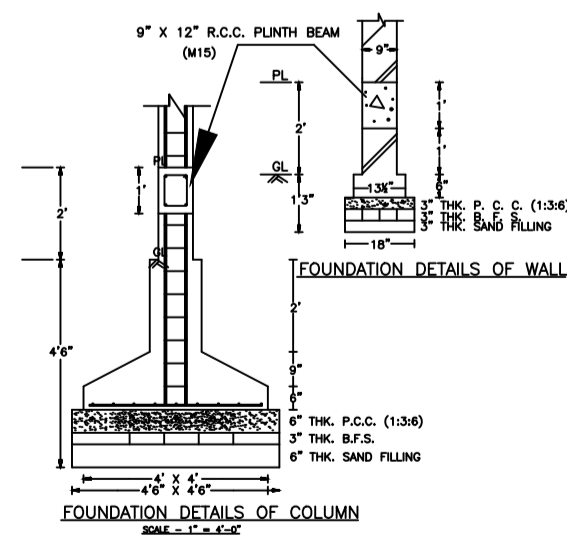

LTP NAME AND SIGNATURE	STRUCTURAL ENG'S NAME AND SIGNATURE	BUILDER NAME AND SIGNATURE	DIGITAL SIGNATURE
SUSHIL KUMAR DMC/ENG/0005/2016			