

Project Title -SMT. AMITA MONDAL

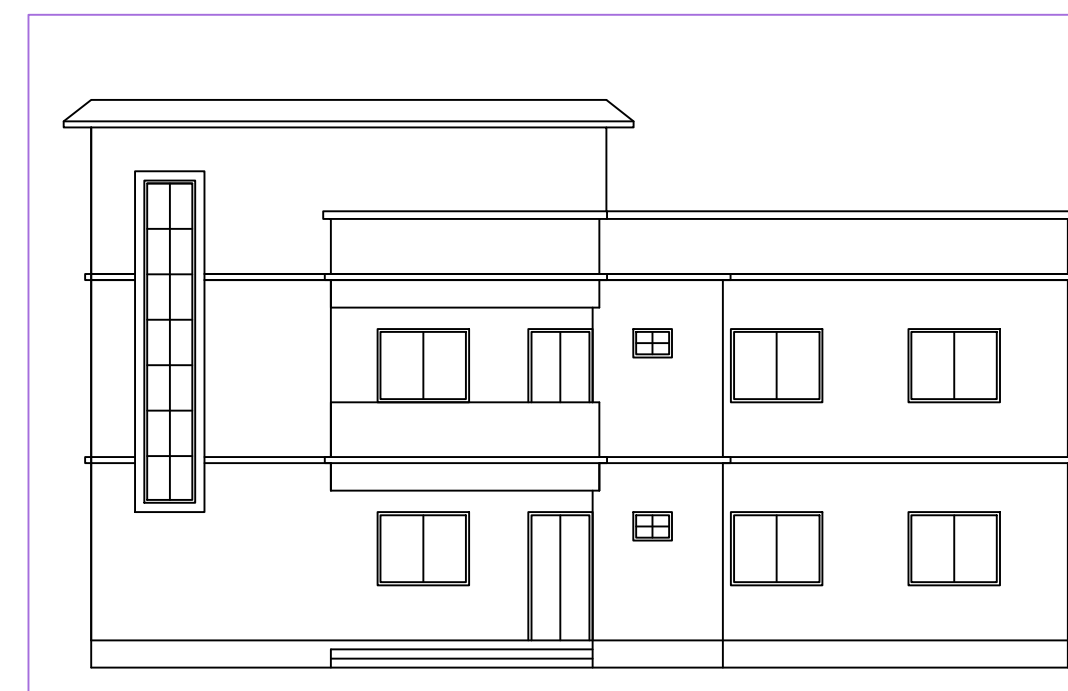

FRONT ELEVATION

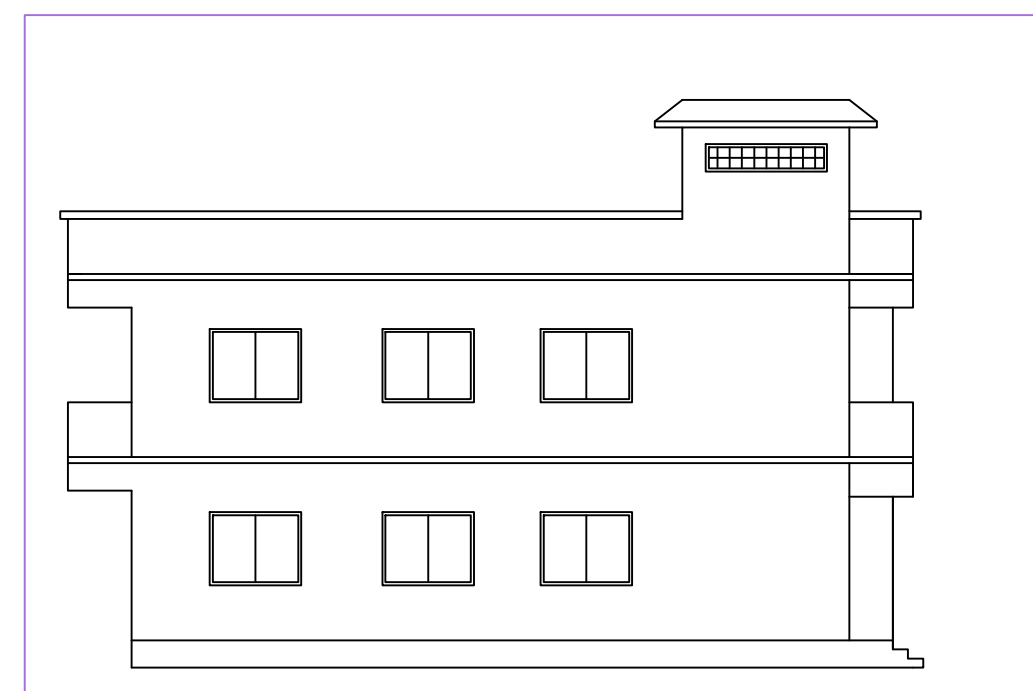

RIGHT SIDE ELEVATION

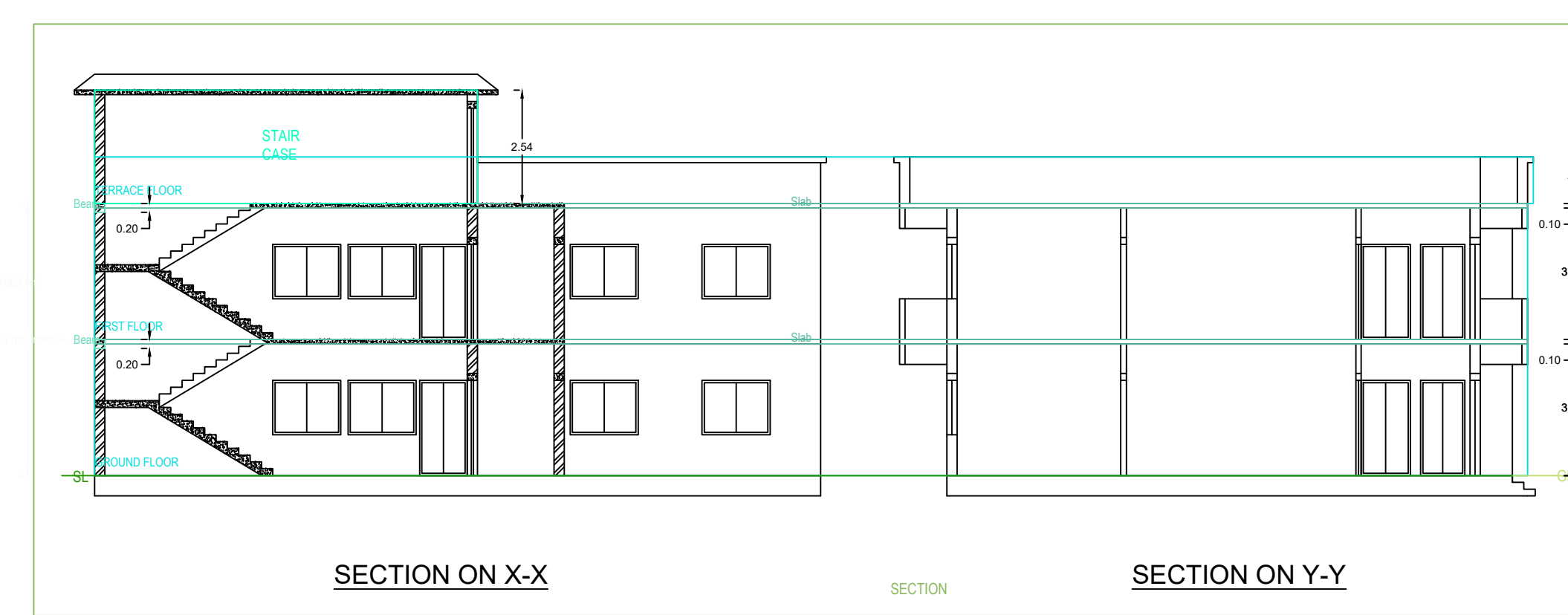

SECTION ON X-X

SECTION ON Y-Y

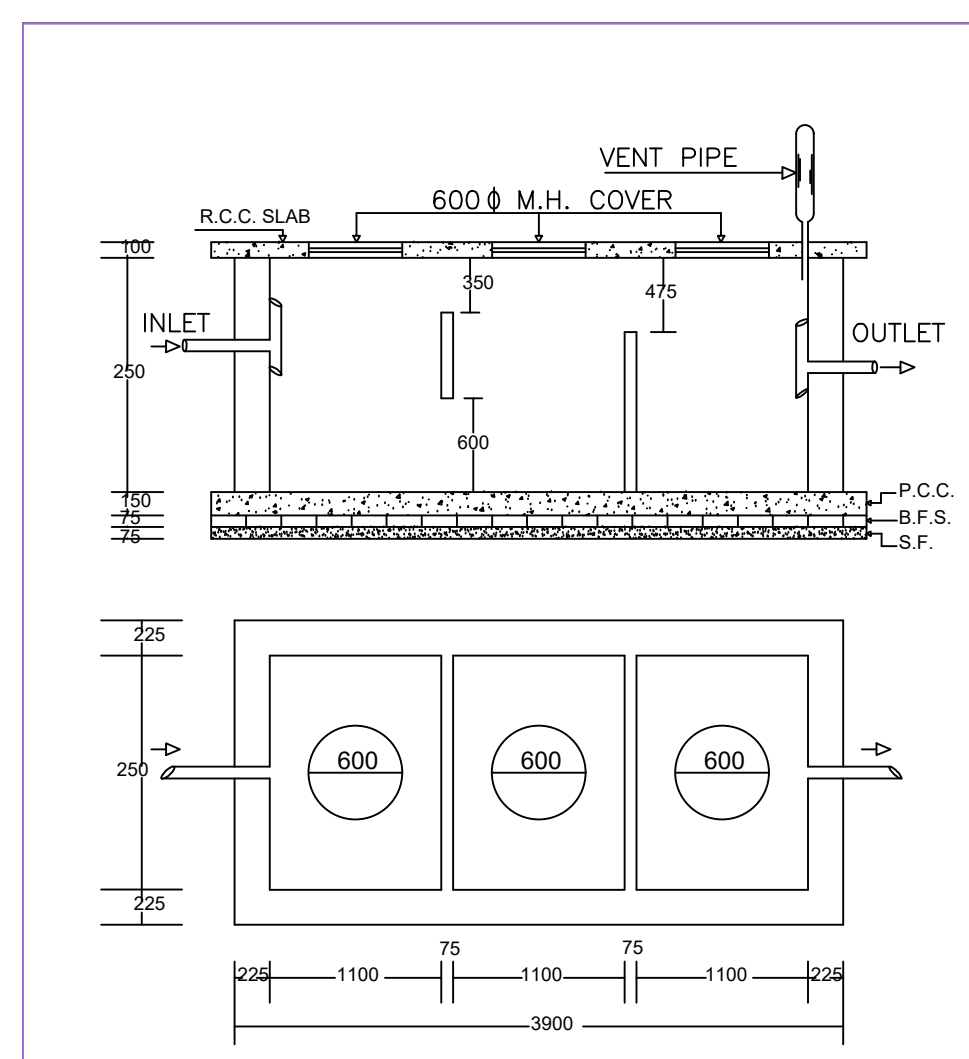

PLAN OF SEPTIC TANK

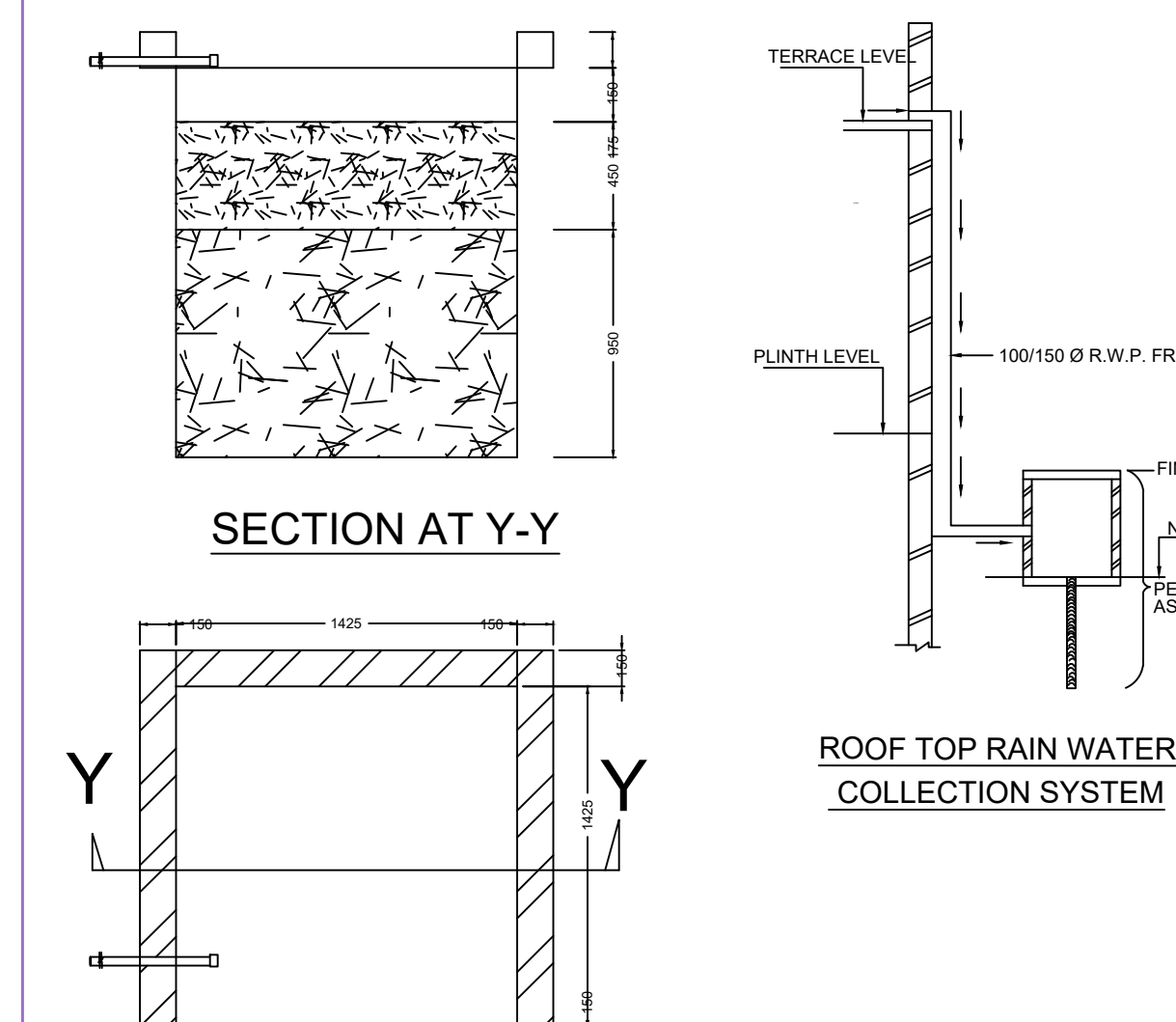

SECTION AT Y-Y

PLAN OF RECHARGE WELL

WATER HARVESTING

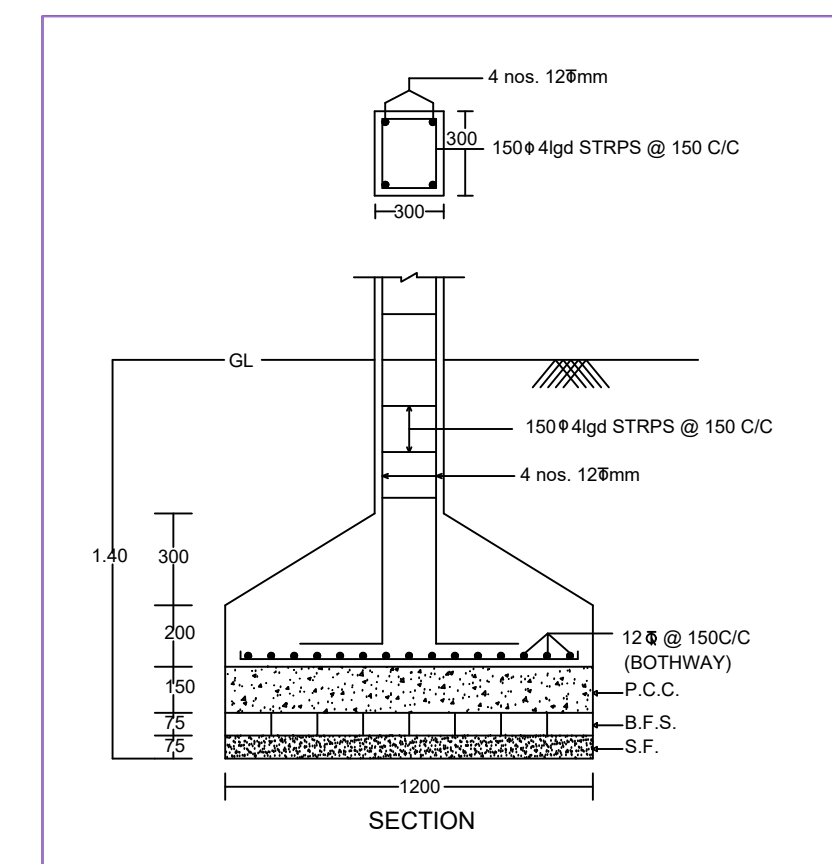

SECTION

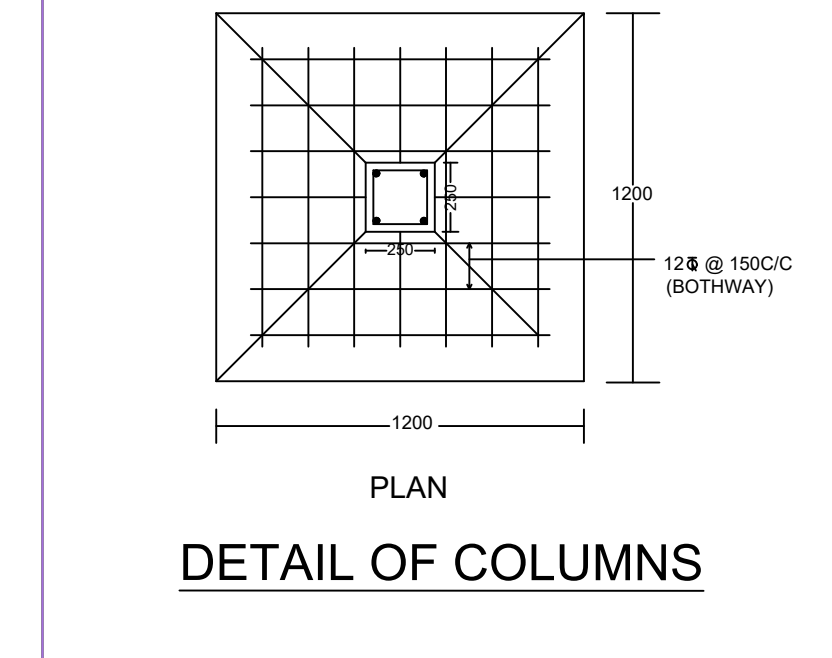

PLAN

DETAIL OF COLUMNS

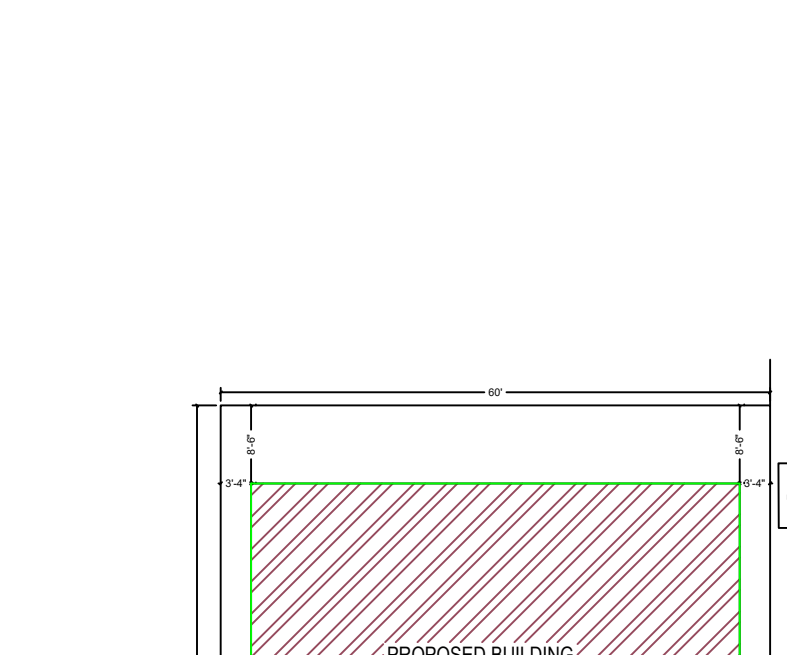
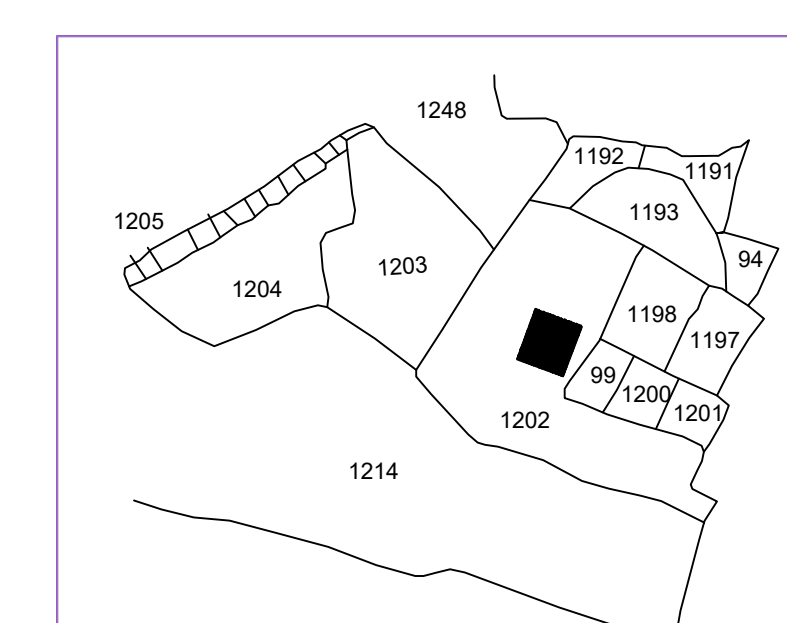
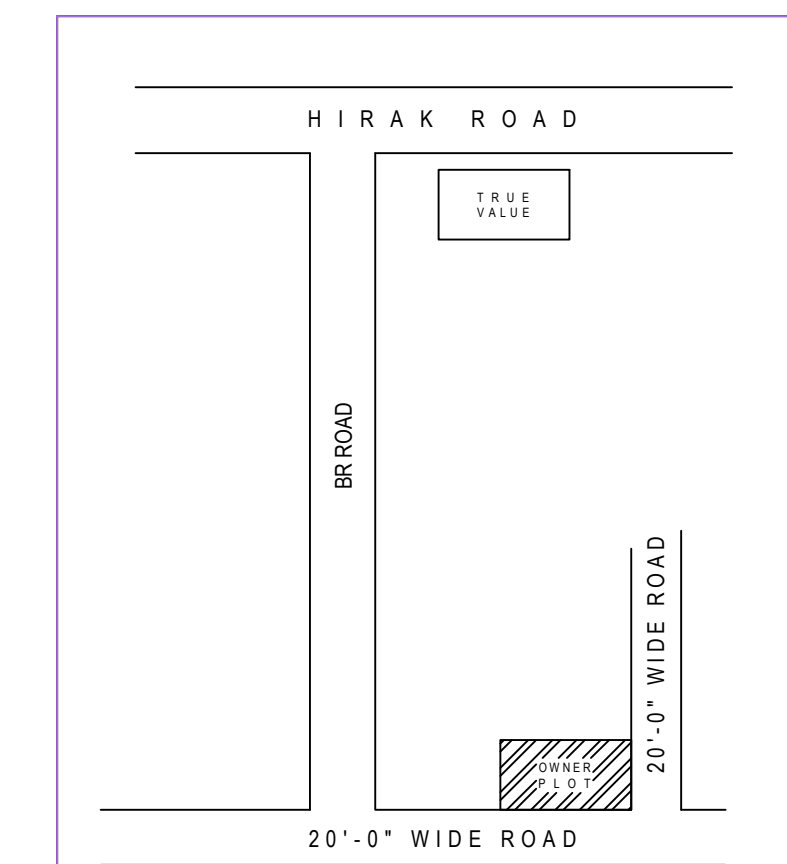

SITE PLAN

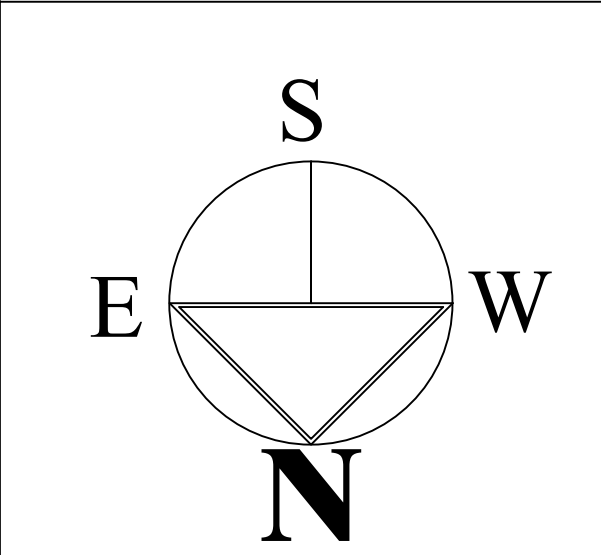

BRIEF SPACEFICATION

FOUNDATION----- CEMENT CONCRETE (1:1.5:3)
 BRICK CLASS BRICK WORK IN CEMENT MORTAR (1:5)
 D.P.C.-----1" D.P.C. IN CEMENT CONCRETE (1:2:4)
 FLOOR-----1" P.S. OVER 3" P.C.C.
 ROOF-----4"THK. R.C.C. ROOF (1:1.5:3)
 LINTEL-----6"THK. R.C.C. LINTEL (1:1.5:3)
 STAIRS-----RISE-- 100", TREAD-- 250"

DETAILS OF AREA

TOTAL LAND AREA (AS PER DEED)-----	334.45 SQM.
TOTAL LAND AREA (AS PER SITE)-----	333.90 SQM.
GROUND FLOOR AREA-----	192.73 SQM.
FIRST FLOOR AREA-----	216.33 SQM.
TOTAL COVERED AREA-----	409.06 SQM.
% PLINTH AREA-----	57.72 %
FAR -----	1.22

SCHEDULE

D = 1.20X2.13	W1 = 1.50X1.20
D1 = 1.05X2.13	W2 = 1.20X1.20
D2 = 0.90X2.13	V = 0.60X0.60

TITLE OF DRAWING

PLAN OF PROPOSED RESIDENTIAL BUILDING OF SMT. AMITA MONDAL W/O SRI. SHYAMAPAD MONDAL OF KALI MANDIR, KHATAL ROAD NEAR GANPATI KUNJA, DHAIYA, P.S + DIST. - DHANBAD, UNDER MOUZA - BHELATAND, NO. - 89, KHATA NO. - 42(NEW-245), PLOT NO. - 776(NEW-1202) IN THE DISTT. OF DHANBAD (J H A R K H A N D) .

SIGNATURE OF OWNER

SIGNATURE OF ENGINEER

SCALE
1:96

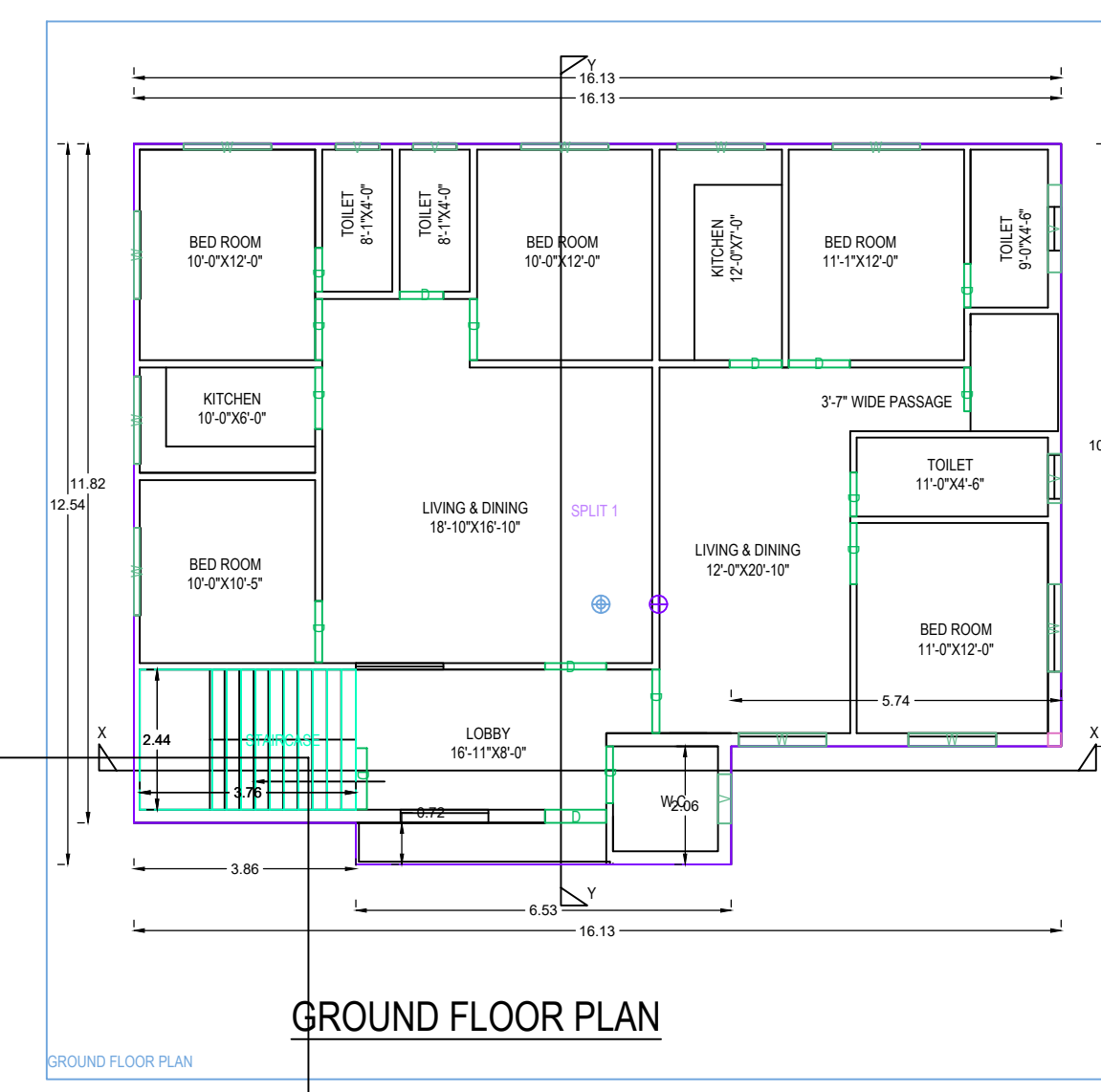
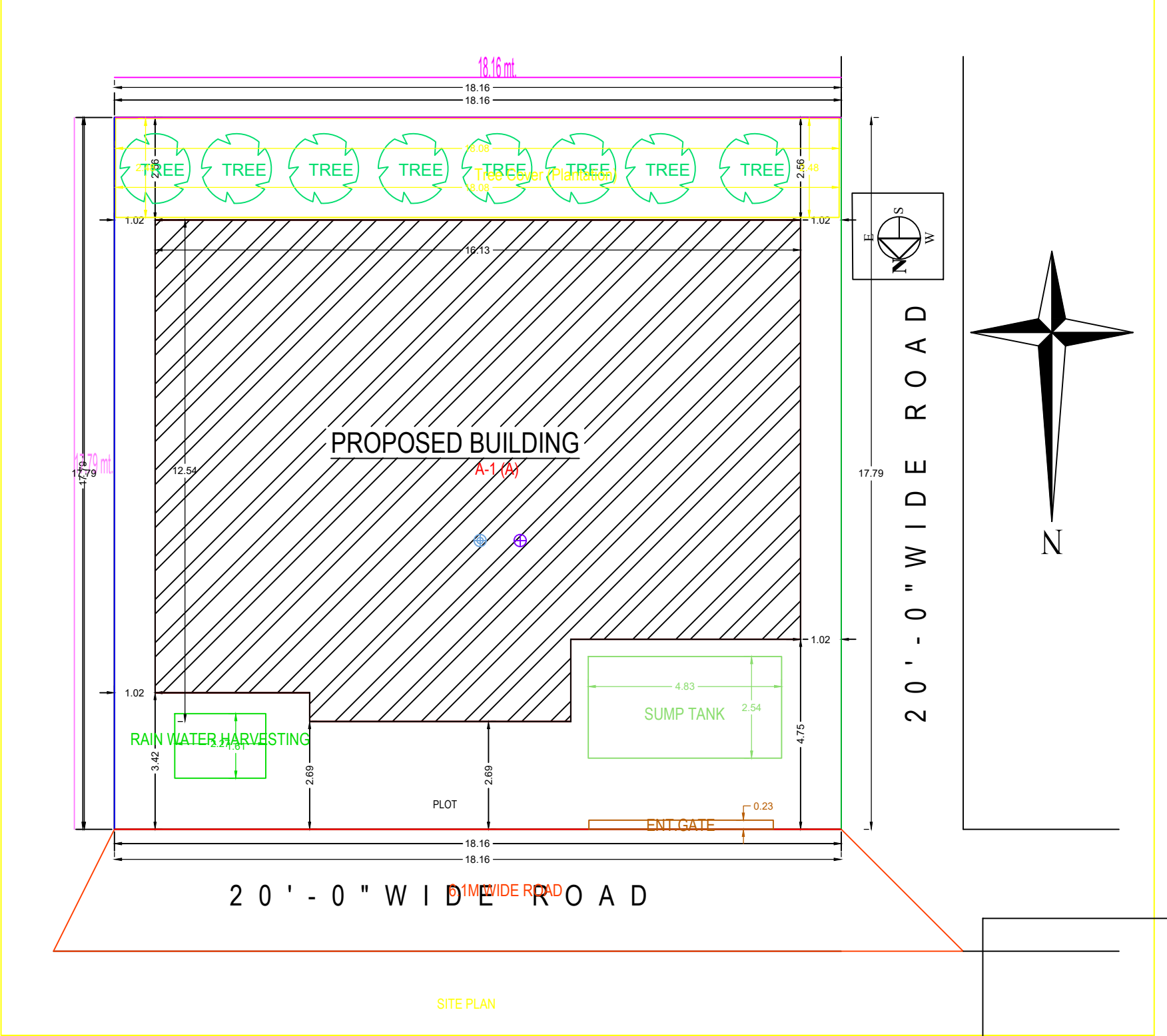

GROUND FLOOR PLAN

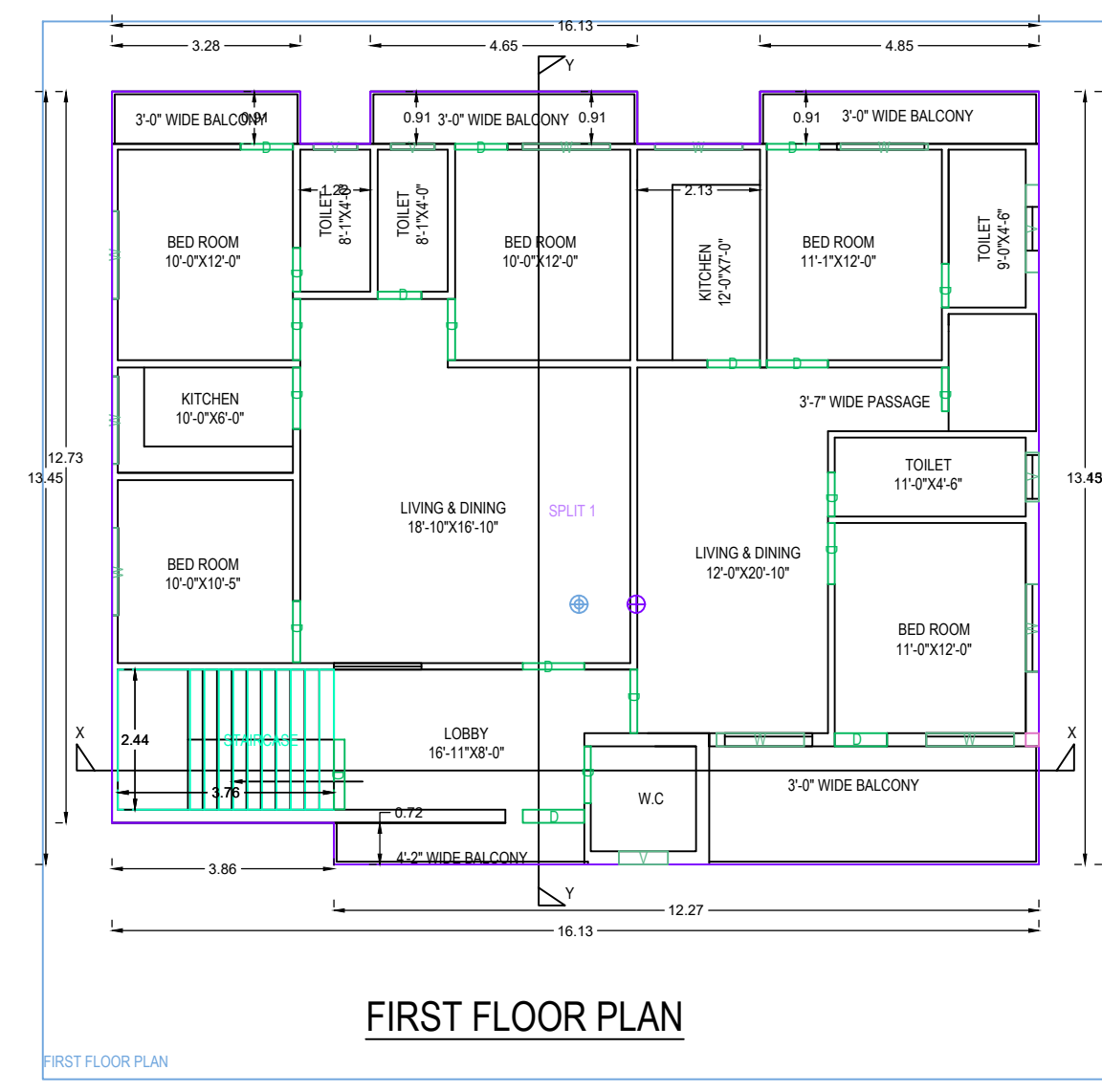

FIRST FLOOR PLAN

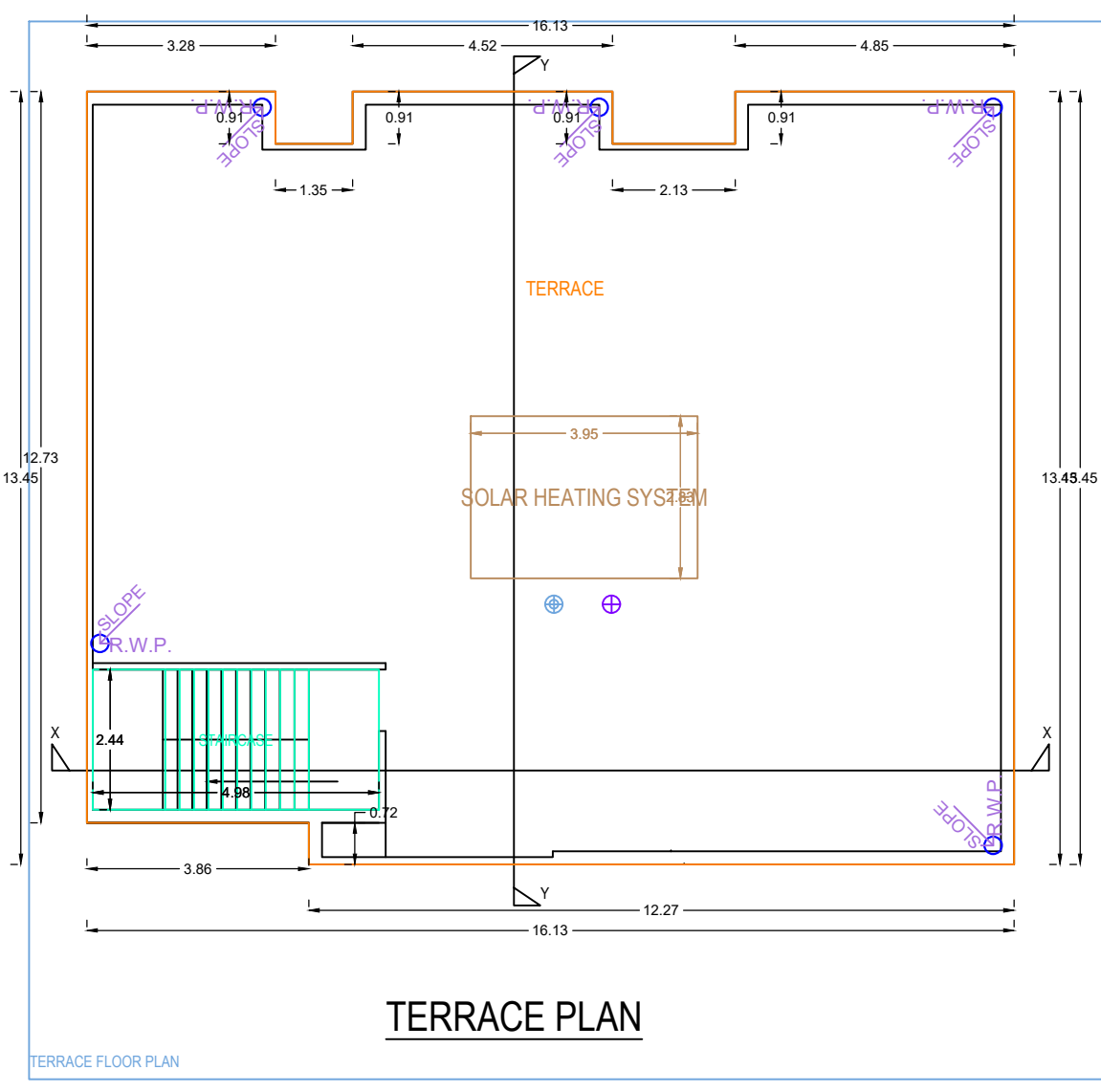

TERRACE PLAN

Building A (A)

Floor Name	Total Built-Up Area (Sq.m)	Proposed FAR Area (Sq.m)	Total FAR Area (Sq.m)	Plot (No.)
Ground Floor	192.73	192.73	192.73	01
First Floor	216.33	216.33	216.33	02
Terrace	100.00	100.00	100.00	03
Total Number of Same Buildings	1	389.06	389.06	01
TOT	389.06	389.06	389.06	01

SCHEDULE OF JOINERY

JOINERY NAME	NAME	LENGTH	HEIGHT	NO.
W.D.	W	2.76	2.15	05
	V	1.50	2.15	06
	W	0.89	2.15	03
	V	1.50	2.15	07
	W	1.10	2.15	02
Door	D	1.22	2.15	01
	W	-	-	08

SCHEDULE OF JOINERY

JOINERY NAME	NAME	LENGTH	HEIGHT	NO.
W.D.	W	2.76	1.50	06
	V	0.89	1.50	04
	W	1.50	1.50	02
	V	1.52	1.50	02
	W	1.52	1.25	03
Door	D	-	-	05
	W	-	-	09

UNBIA Table for Building A (A)

FLOOR	Name	UNBIA Type	UNBIA Area	Carpet Area	No. of Rooms	No. of Tenants
GROUND FLOOR	SPLIT 1	FLAT	389.79	389.06	17	1
		TOT	389.79	389.06	17	1

PROJECT/CLIENT	SHYAMAPAD MONDAL	VERSION NO.	1.0	DATE	10/05/2025
PROJECT DETAIL	Plot No.	Plot Area	Plot Boundary	Plot Owner	Plot Approval
CLIENT INFORMATION	Client Name	Client Address	Client Contact	Client Email	Client Phone
PROJECT INFORMATION	Project Name	Project Location	Project Status	Project Start	Project End
DESIGN INFORMATION	Design No.	Design Date	Design Scale	Design Author	Design Checker
REVISIONS	Rev. No.	Rev. Description	Rev. Date	Rev. By	Rev. Check

REVISIONS	NO.	DESCRIPTION	DATE	BY	CHECK
1	1	Initial Design	10/05/2025	AM	AM

REVISIONS	NO.	DESCRIPTION	DATE	BY	CHECK
2	2	Final Design	10/05/2025	AM	AM

REVISIONS	NO.	DESCRIPTION	DATE	BY	CHECK
3	3	Final Design	10/05/2025	AM	AM

REVISIONS	NO.	DESCRIPTION	DATE	BY	CHECK
4	4	Final Design	10/05/2025	AM	AM

REVISIONS	NO.	DESCRIPTION	DATE	BY	CHECK
5	5	Final Design	10/05/2025	AM	AM

REVISIONS	NO.	DESCRIPTION	DATE	BY	CHECK
6	6	Final Design	10/05/2025	AM	AM

REVISIONS	NO.	DESCRIPTION	DATE	BY	CHECK
7	7	Final Design	10/05/2025	AM	AM

REVISIONS	NO.	DESCRIPTION	DATE	BY	CHECK
8	8	Final Design	10/05/2025	AM	AM

REVISIONS	NO.	DESCRIPTION	DATE	BY	CHECK
9	9	Final Design	10/05/2025	AM	AM

REVISIONS	NO.	DESCRIPTION	DATE	BY	CHECK
10	10	Final Design	10/05/2025	AM	AM

REVISIONS	NO.	DESCRIPTION	DATE	BY	CHECK
11	11	Final Design	10/05/2025	AM	AM

REVISIONS	NO.	DESCRIPTION	DATE	BY	CHECK
12	12	Final Design	10/05/2025	AM	AM

REVISIONS	NO.	DESCRIPTION	DATE	BY	CHECK
13	13	Final Design	10/05/2025	AM	AM

REVISIONS	NO.	DESCRIPTION	DATE	BY	CHECK
14	14	Final Design	10/05/2025	AM	AM

REVISIONS	NO.	DESCRIPTION	DATE	BY	CHECK
15	15	Final Design	10/05/2025	AM	AM

REVISIONS	NO.	DESCRIPTION	DATE	BY	CHECK
16	16	Final Design	10/05/2025	AM	AM

REVISIONS	NO.	DESCRIPTION	DATE	BY	CHECK
17	17	Final Design	10/05/2025	AM	AM

REVISIONS	NO.	DESCRIPTION	DATE	BY	CHECK
18	18	Final Design	10/05/2025	AM	AM

REVISIONS	NO.	DESCRIPTION	DATE	BY	CHECK
19	19	Final Design	10/05/2025	AM	AM

REVISIONS	NO.	DESCRIPTION	DATE	BY	CHECK
20	20	Final Design	10/05/2025	AM	AM