

Proposal Basic Information	
Proposal File No.	DMC/BP/0319/W21/2022
Owner Name	SMT. ANJALI SINGH
Khata No	29 (NEW 220)
Plot No	89,103 (NEW 110,123)
Village Name	Baramuri
Use	Residential
SubUse	Bungalow/ Dwelling / Non Apartment

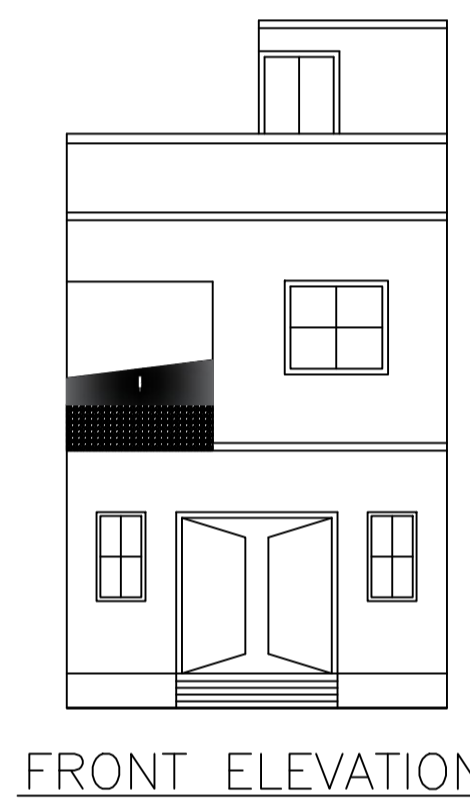
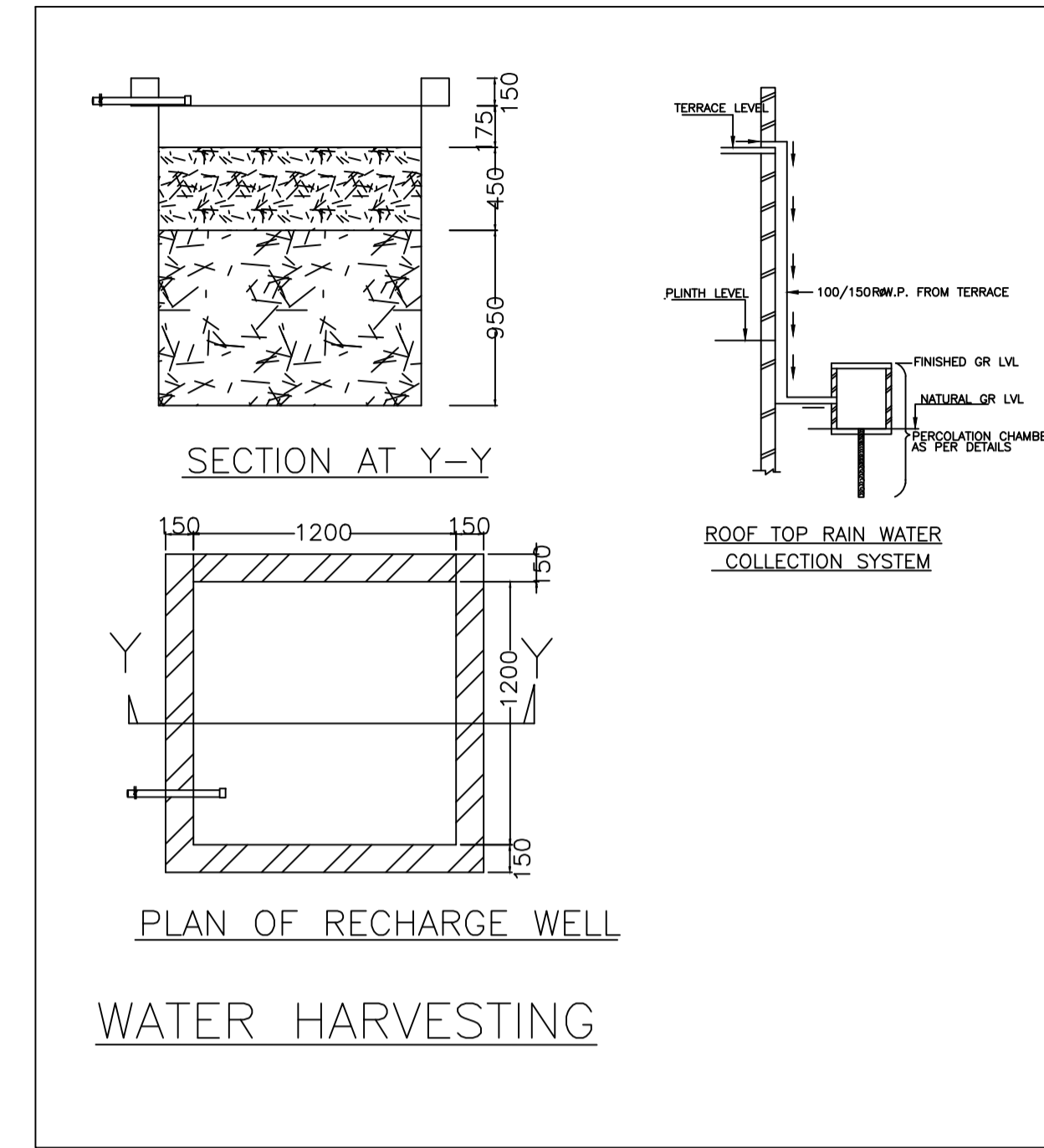
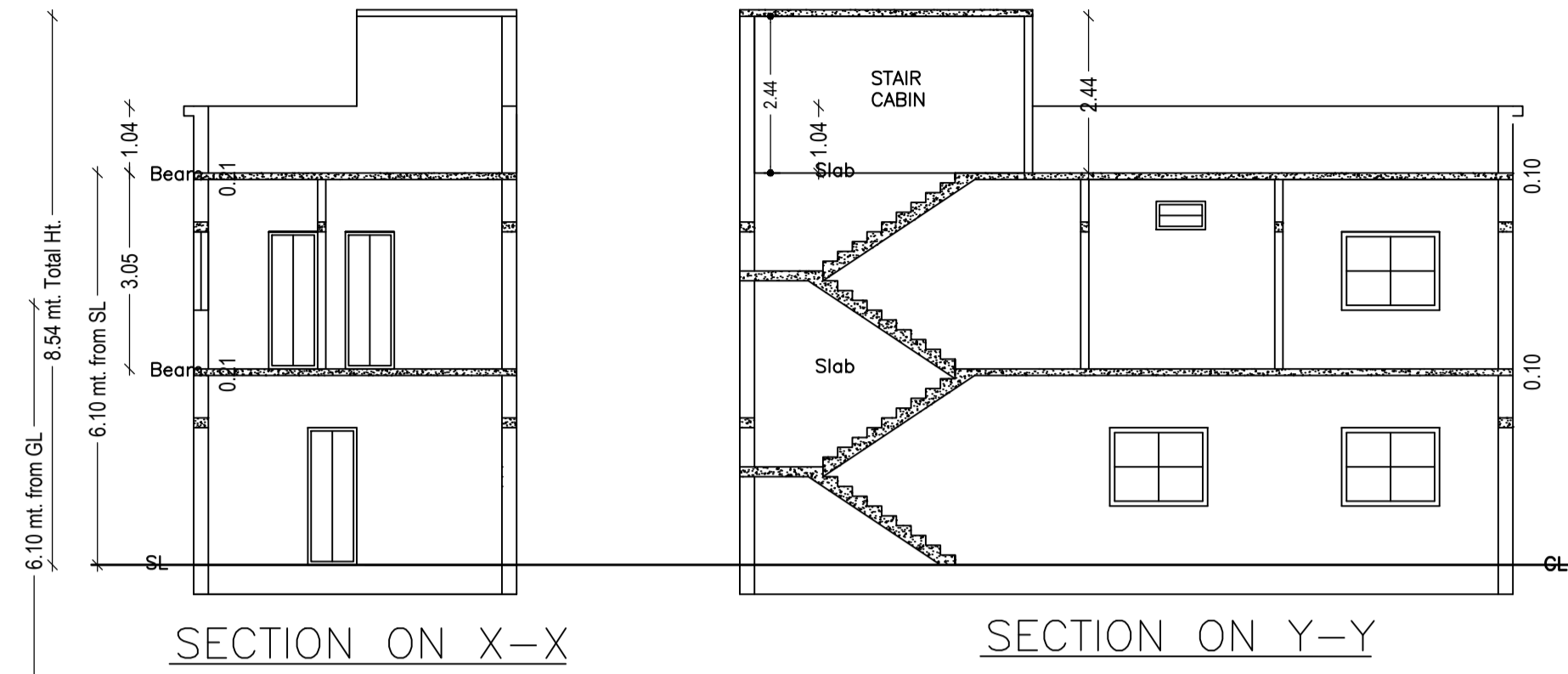
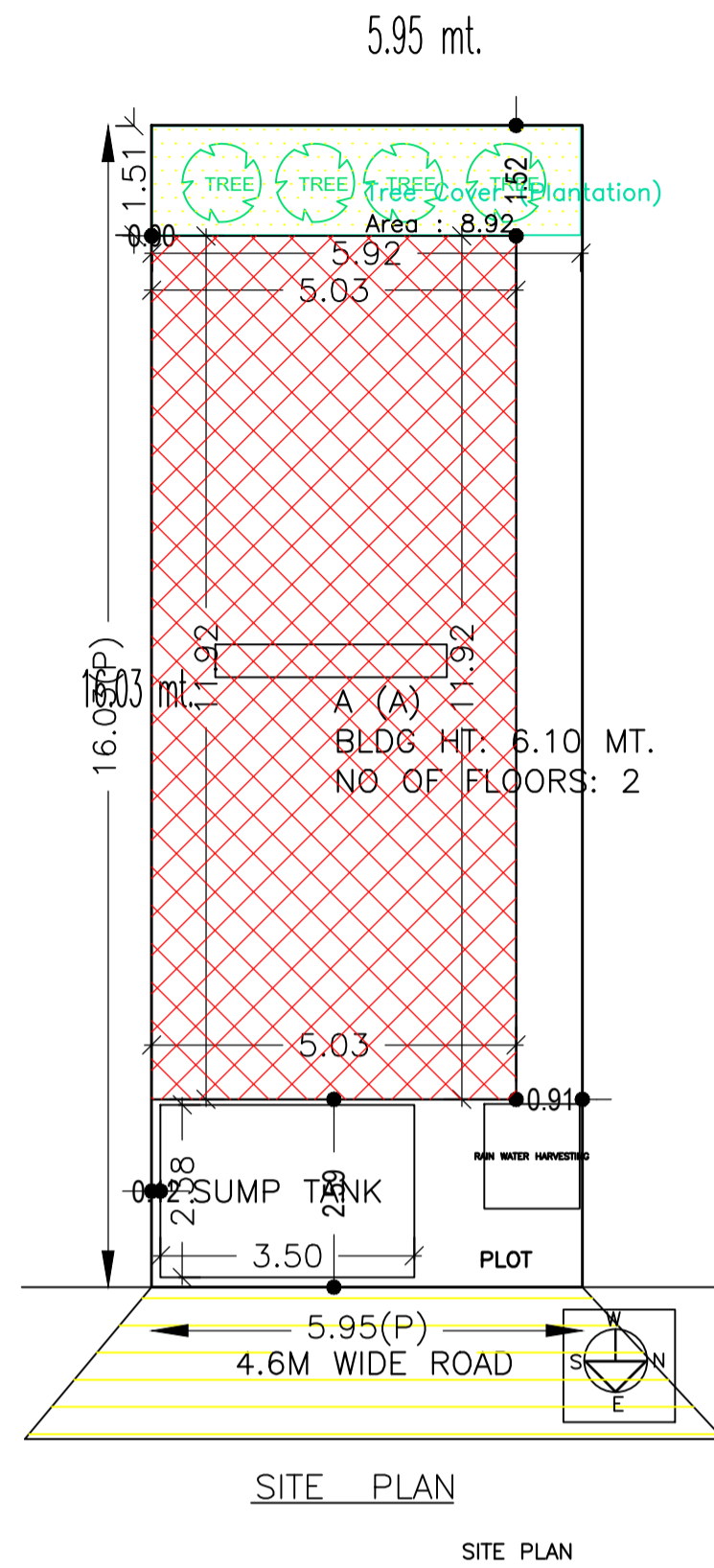
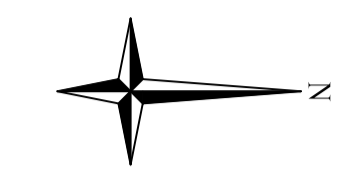

AREA STATEMENT		VERSION NO. : 1.0.64
DHANBAD MUNICIPAL CORPORATION		VERSION DATE: 16/10/2020
PROJECT DETAIL:		
Region: JHARKHAND URBAN LOCAL BODIES	Plot Use: Residential	
District: DHANBAD	Plot SubUse: Bungalow/ Dwelling / Non Apartment	
Authority: DHANBAD MUNICIPAL CORPORATION	PlotNearby/ReligiousStructure: NA	
Inward No: DMC/BP/0319/W21/2022	Plot/SubPlot No: 89,103 (NEW 110,123)	
Application Type: General Proposal	North: Plot No. - NAYA PLOT NO. 110 & 123 KA ANSH	
Project Type: Building Permission	South: Plot No. - ANJU KUMARI	
Nature of Development: New	East: Road Width - 4.72	
Location of Development Area: Old Area	West: Plot No. - NAYA PLOT NO. 110 KA ANSH	
AREA DETAILS:		
AREA OF PLOT (Minimum)	(A)	SQ.MT. 95.31
NET AREA OF PLOT(Gross Plot Area - Deduction from Gross Plot area)	(A-Deductions)	95.31
Deduction for Balance Plot Area(from Gross Plot Area)		
Common Plot		8.92
Total		8.92
BALANCE AREA OF PLOT(Net Plot Area - Recreational/Amenity space)	(A-Deductions)	86.39
PLOT AREA FOR COVERAGE(Net Plot Area)	(A-Deductions)	95.31
Plot Area for FAR (Net Plot Area + RoadWidening Area)	(A-Deductions)	95.31
COVERAGE CHECK		
Permissible Coverage area (70.00 %)		66.72
Proposed Coverage Area (62.89 %)		59.94
Total Prop. Coverage Area (62.89 %)		59.94
Balance coverage area (7.11 %)		6.78
FAR CHECK		
Perm. FAR Area (1.500)		142.96
Total Perm. FAR area		142.96
Residential FAR		119.88
Proposed FAR Area		119.88
Total Proposed FAR Area		119.88
Consumed FAR (Factor)		1.26
Balance FAR Area		23.08
BUILT UP AREA CHECK		
Total Proposed BuiltUp Area		119.88
ARCHITECT (Regd)		PARTHA PAL
ENGINEER (Regd)		
SUPERVISOR (Regd)		
OWNER (Regd)		SMT. ANJALI SINGH
DEVELOPMENT AUTHORITY		LOCAL BODY

COLOR INDEX	
PLOT BOUNDARY	Black
ABUTTING ROAD	Green
PROPOSED CONSTRUCTION	Red
COMMON PLOT	Yellow
ROAD WIDENING AREA	Blue
EXISTING (To be retained)	Light Blue
EXISTING (To be demolished)	Dark Blue

Building :A (A)					
Floor Name	Total Built Up Area (Sq.mt.)	Proposed FAR Area (Sq.mt.)	Total FAR Area (Sq.mt.)	Total Consumed Additional FAR Area (Sq.mt.)	Tnmt (No.)
Ground Floor	59.94	59.94	59.94	59.94	01
First Floor	59.94	59.94	59.94	59.94	00
Terrace Floor	0.00	0.00	0.00	0.00	00
Total :	119.88	119.88	119.88	119.88	01
Total Number of Same Buildings :	1				
Total :	119.88	119.88	119.88	119.88	01

SCHEDULE OF DOOR:

BUILDING NAME	NAME	LENGTH	HEIGHT	NOS
A (A)	D	0.76	2.10	03
A (A)	D	0.91	2.10	03
A (A)	D	2.13	2.10	01

SCHEDULE OF WINDOW/VENTILATION:

BUILDING NAME	NAME	LENGTH	HEIGHT	NOS
A (A)	W	1.20	1.20	03
A (A)	W	1.22	1.20	14

UnitBUA Table for Building :A (A)

FLOOR	Name	UnitBUA Type	UnitBUA Area	Carpet Area	No. of Rooms	No. of Tenement
GROUND FLOOR PLAN	SPLIT 1	FLAT	119.88	119.77	2	1
FIRST FLOOR PLAN	SPLIT 1	FLAT	0.00	0.00	6	0
Total:	-	-	119.88	119.77	8	1

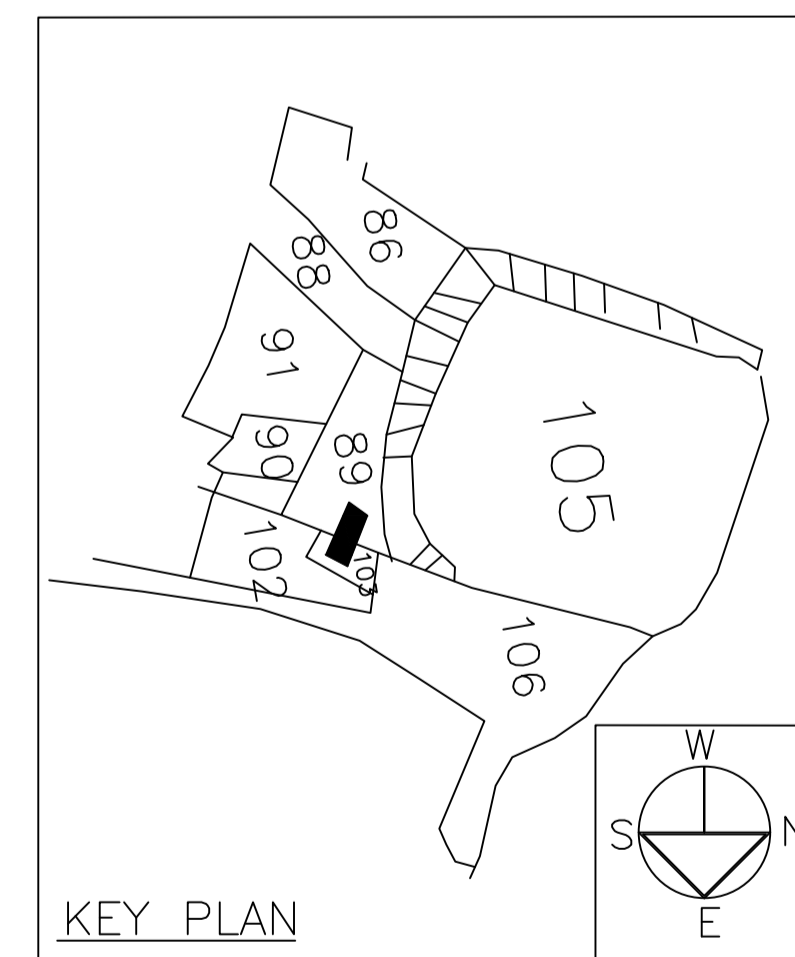
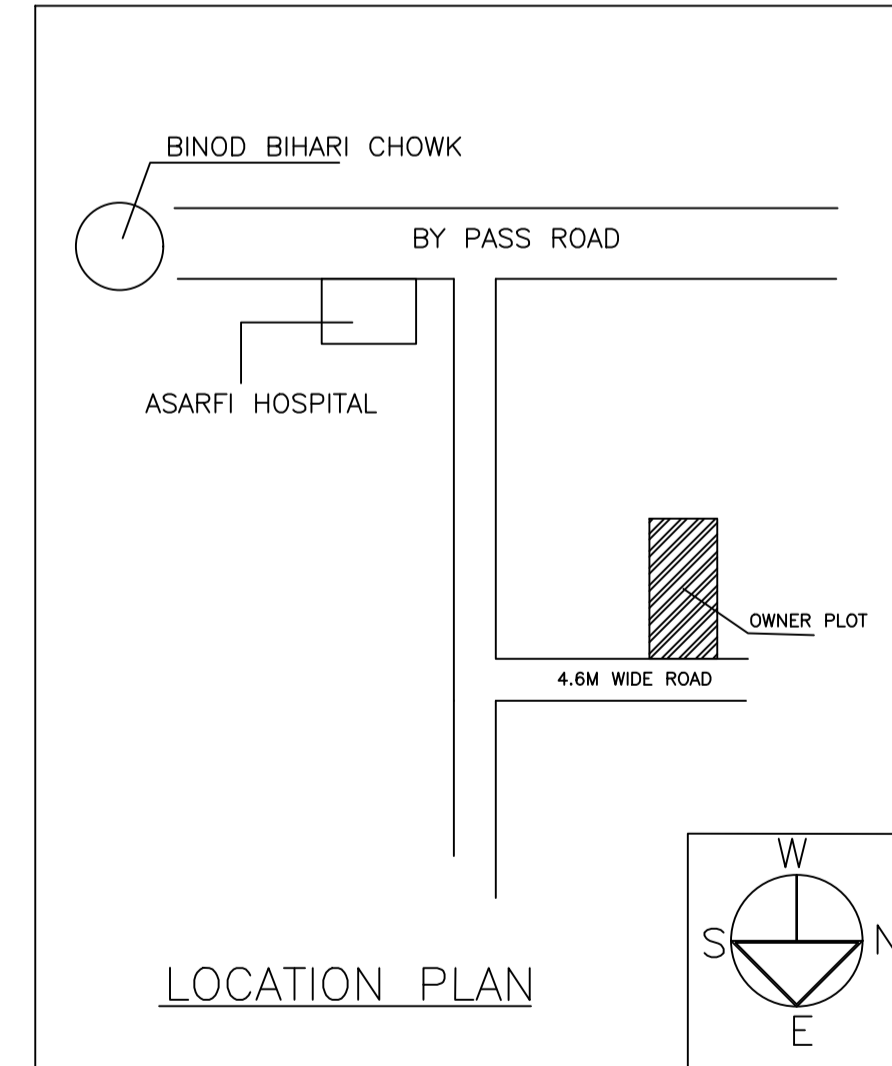
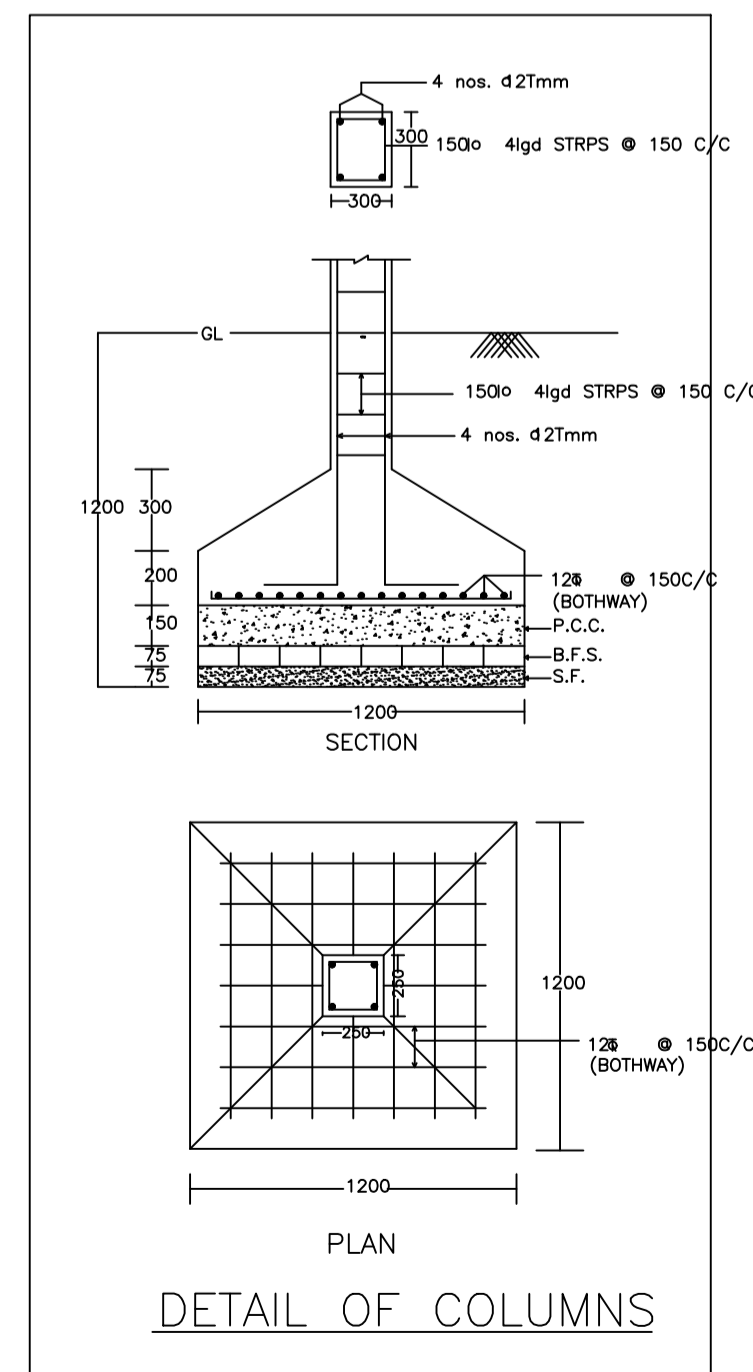

LTP NAME AND SIGNATURE	STRUCTURAL ENG'S NAME AND SIGNATURE	BUILDER NAME AND SIGNATURE	DIGITAL SIGNATURE
PARTHA PAL DMC/ENG/0021/2016			

Proposal Basic Information	
Proposal File No.	DMC/BP/0319/W21/2022
Owner Name	SMT. ANJALI SINGH
Khata No	29 (NEW 220)
Plot No	89,103 (NEW 110,123)
Village Name	Baramuri
Use	Residential
SubUse	Bungalow/ Dwelling / Non Apartment

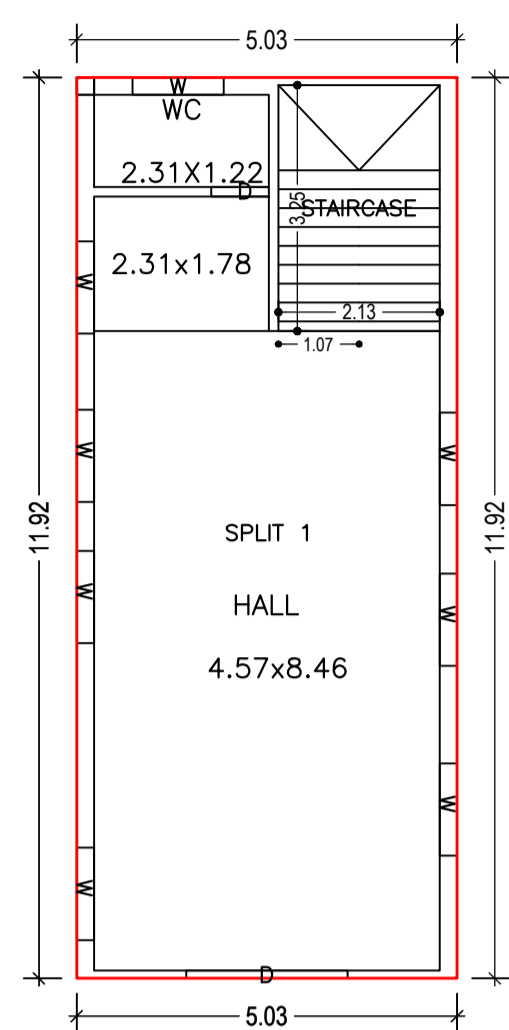

GROUND FLOOR PLAN
(Proposed)
(SCALE 1:100)

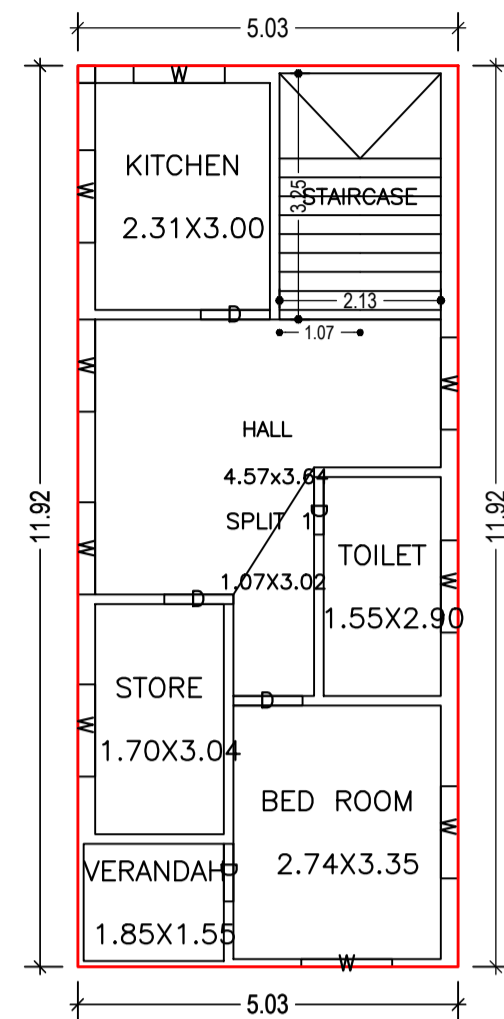

FIRST FLOOR PLAN
(Proposed)
(SCALE 1:100)

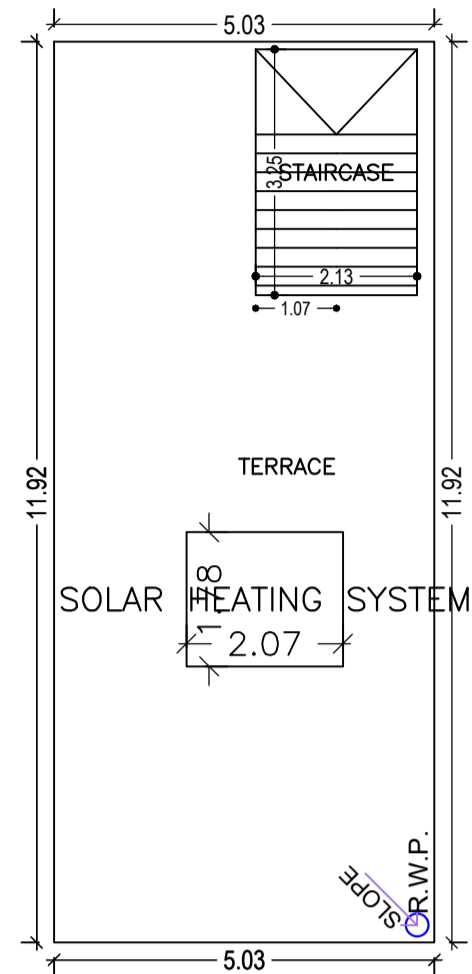

TERRACE FLOOR PLAN
(SCALE 1:100)

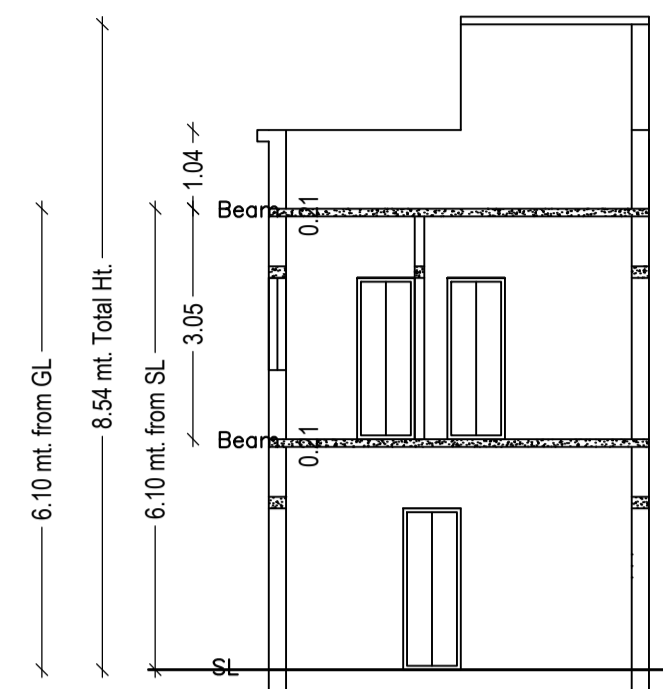

SECTION ON X-X

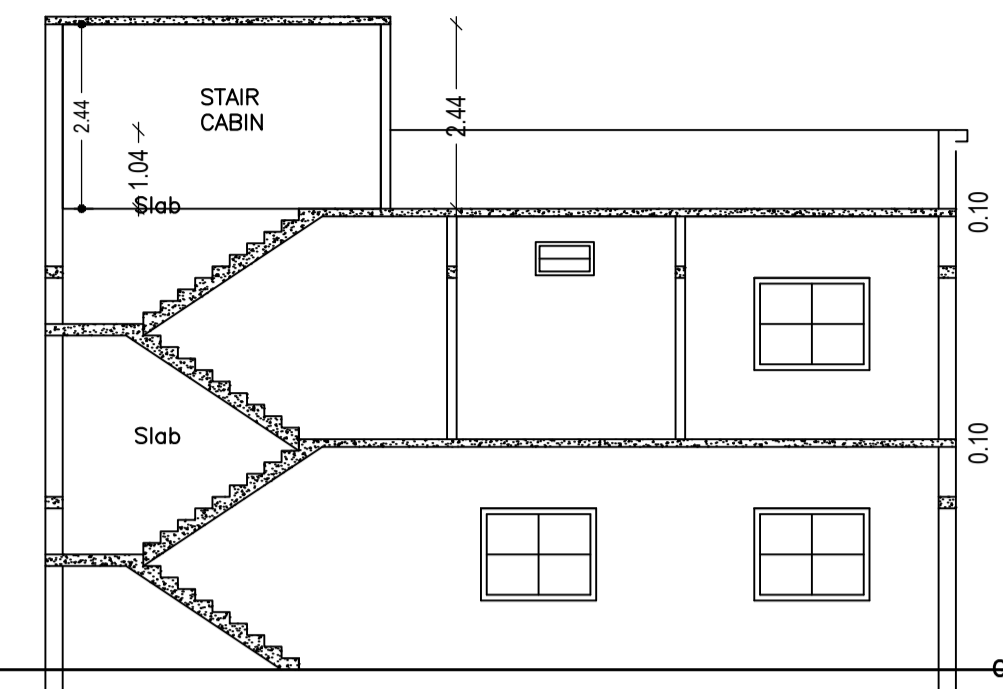

SECTION ON Y-Y

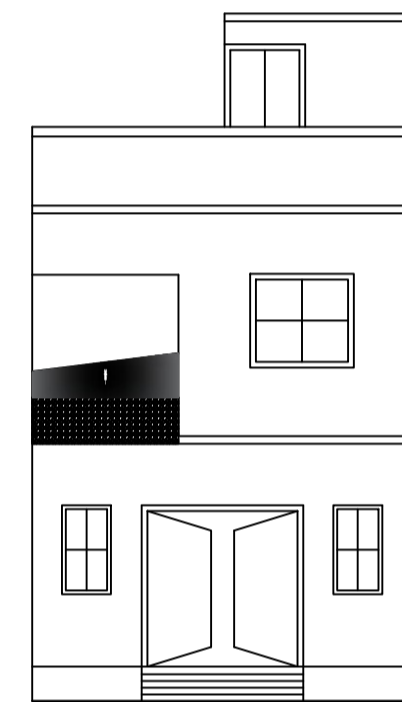
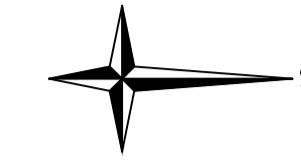

FRONT ELEVATION

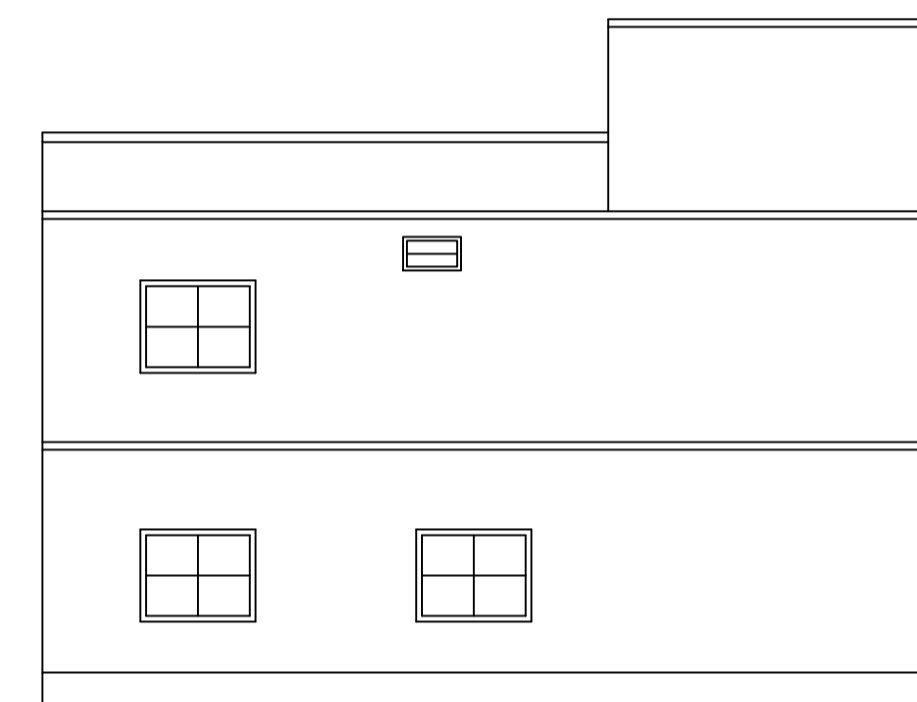

RIGHT SIDE ELEVATION

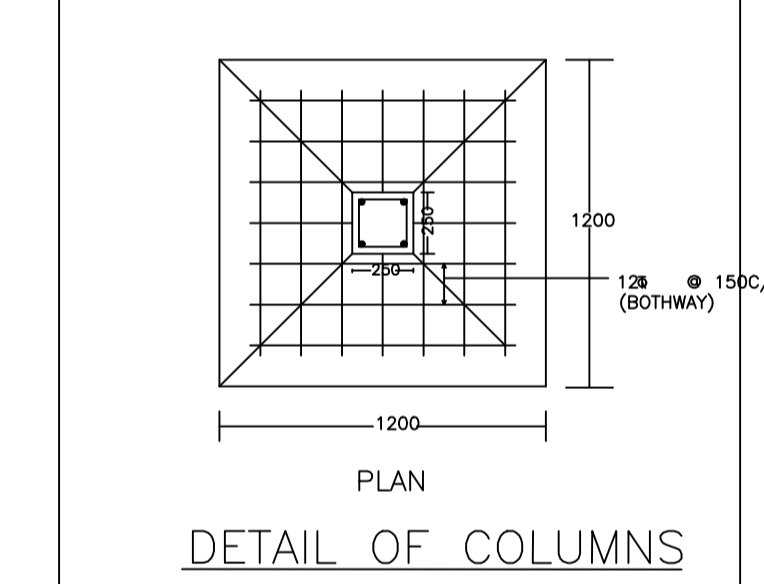
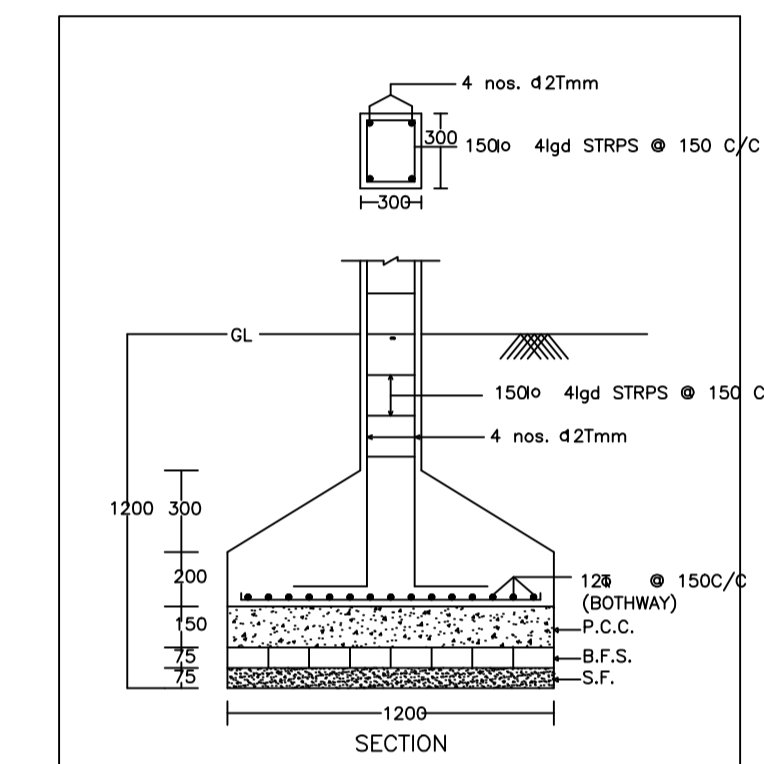

DETAIL OF COLUMNS

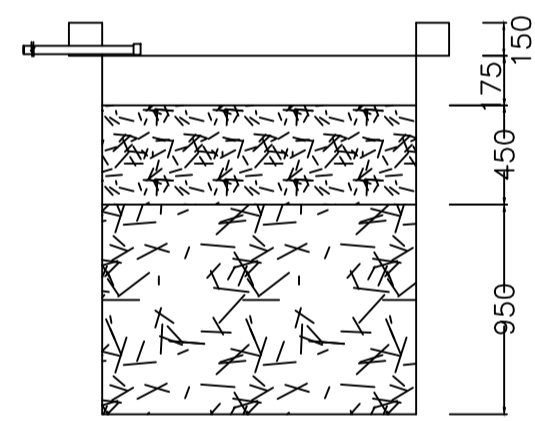

SECTION AT Y-Y

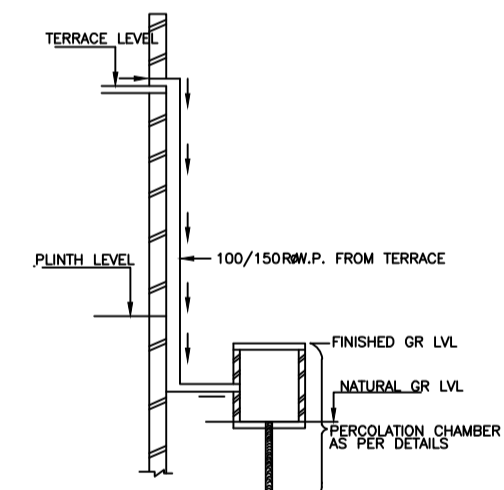

ROOF TOP RAIN WATER
COLLECTION SYSTEM

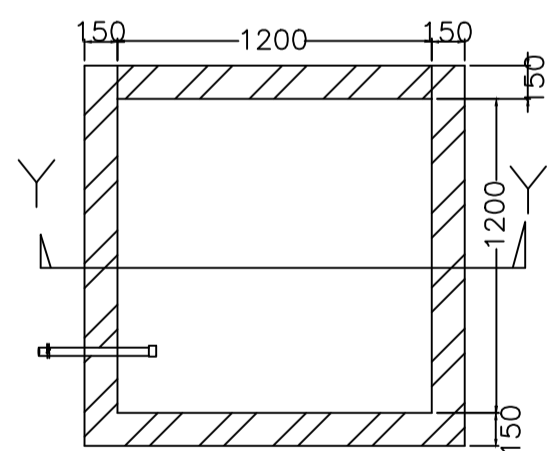

PLAN OF RECHARGE WELL
WATER HARVESTING

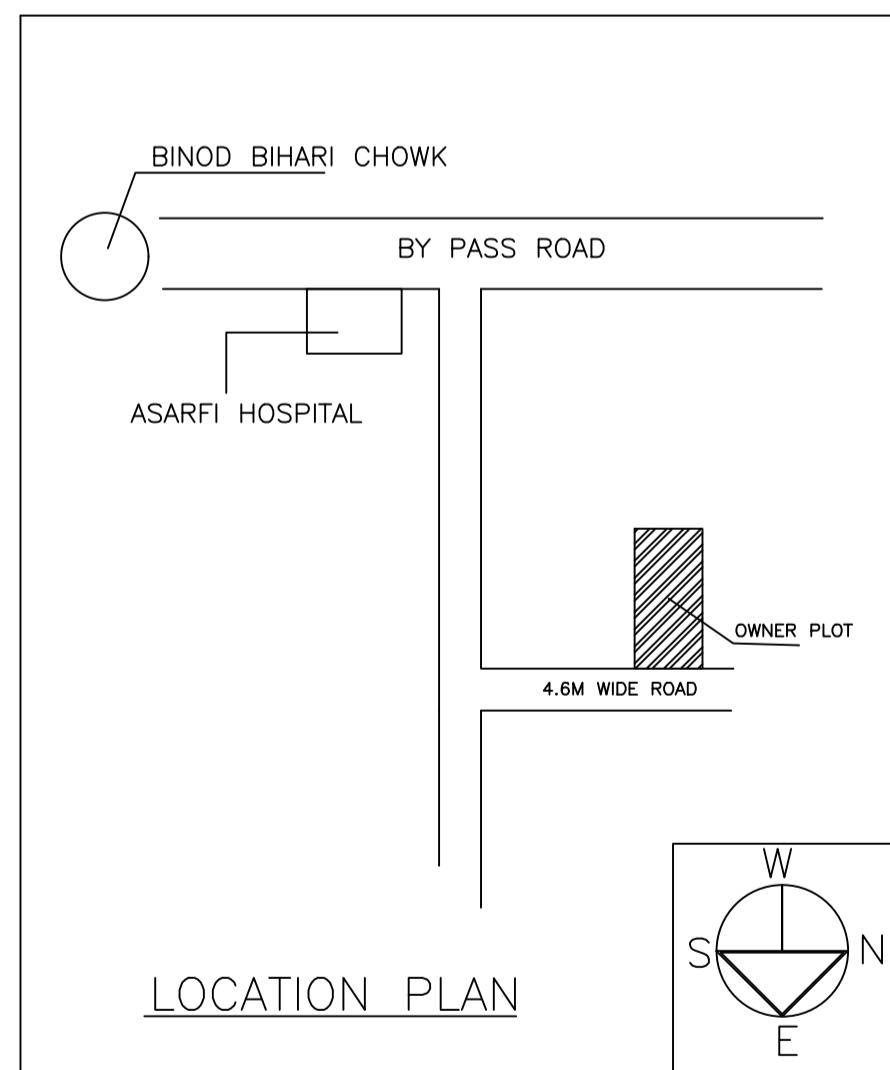

LOCATION PLAN

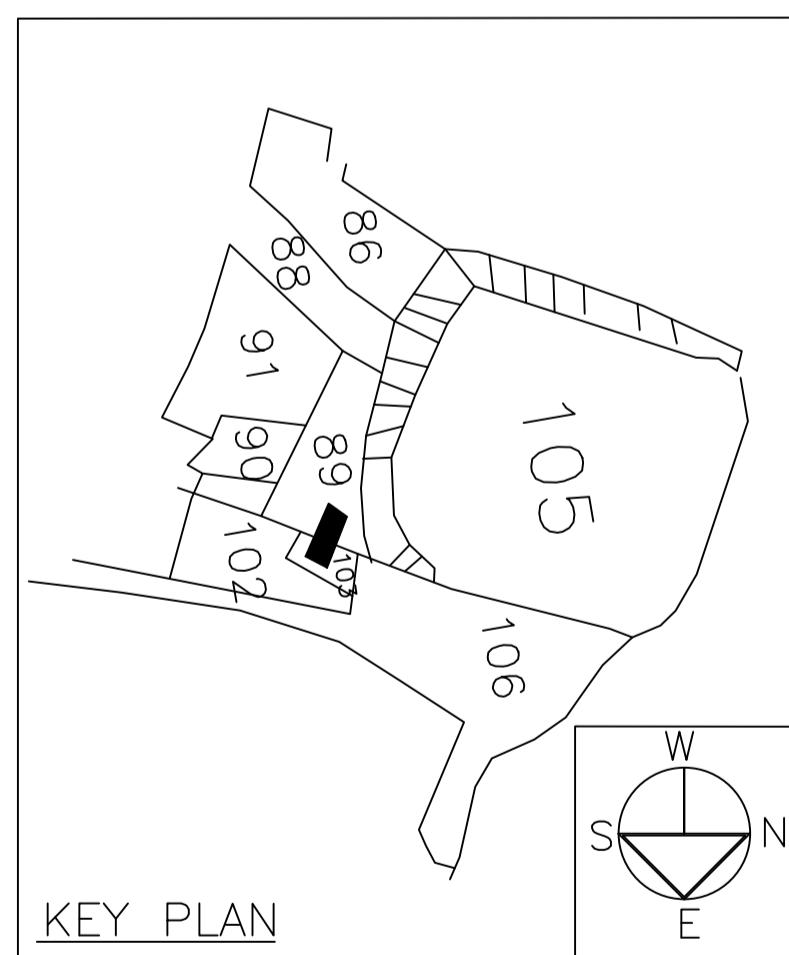

KEY PLAN

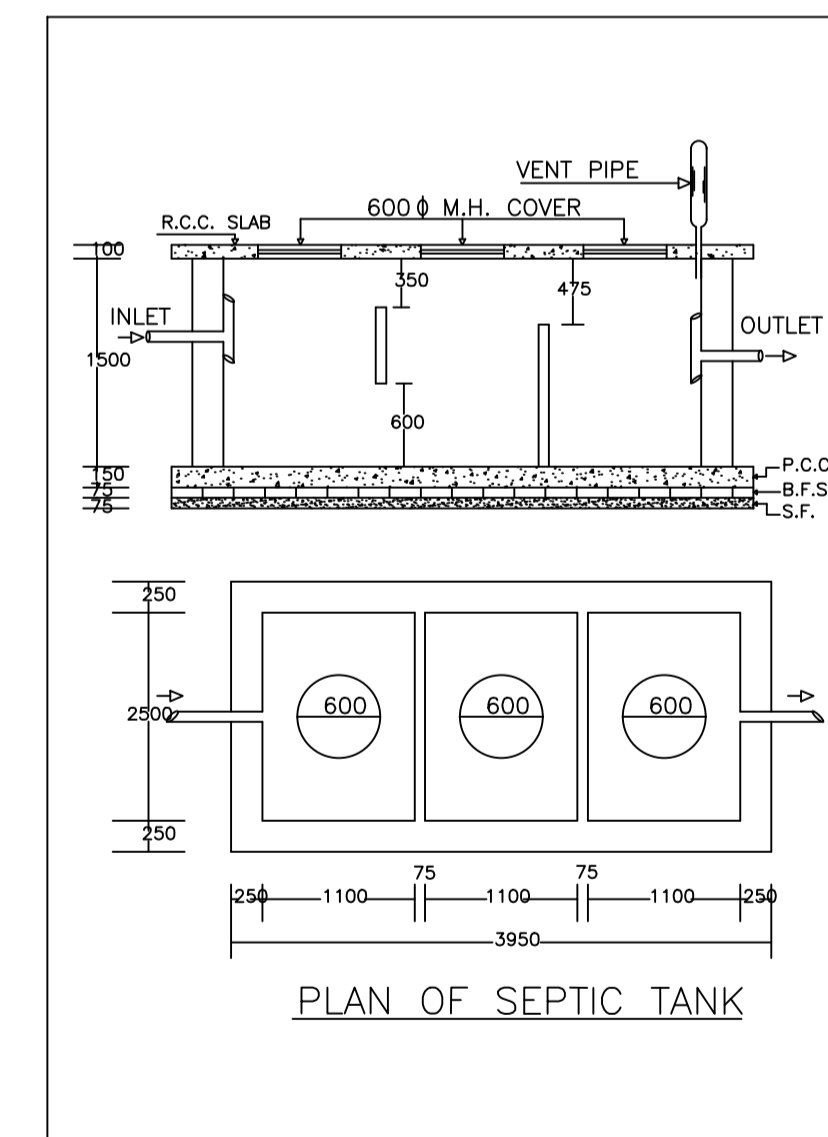

PLAN OF SEPTIC TANK

LTP NAME AND SIGNATURE	STRUCTURAL ENG'S NAME AND SIGNATURE	BUILDER NAME AND SIGNATURE	DIGITAL SIGNATURE
PARTHA PAL DMC/ENG/0021/2016			