

Project Title - KISHORE KUMAR

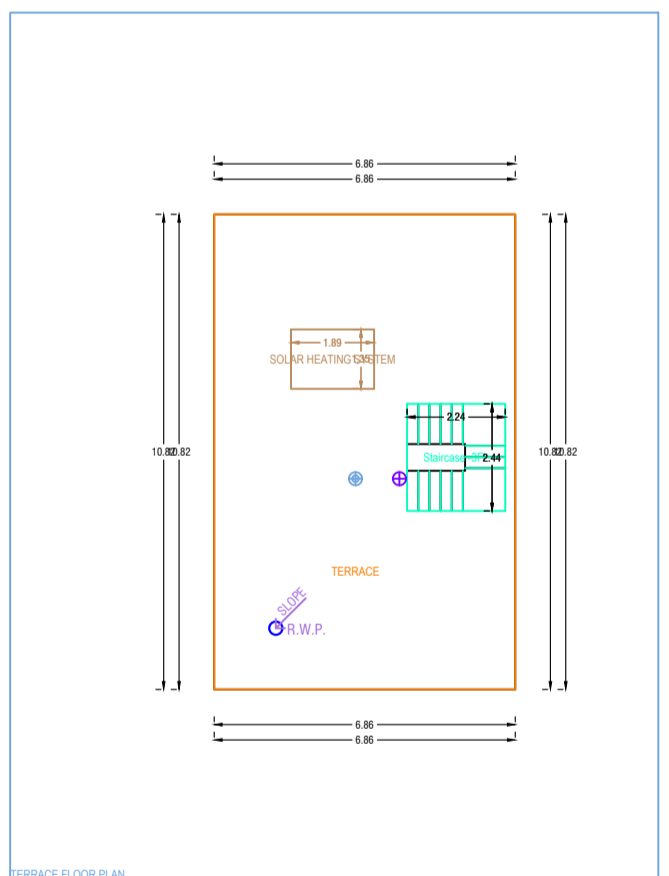
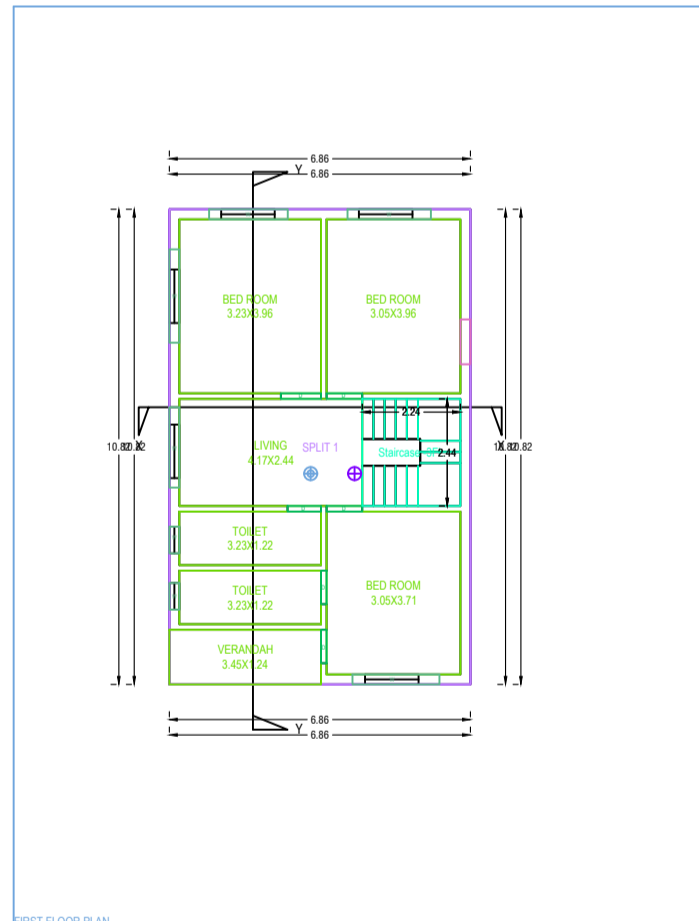
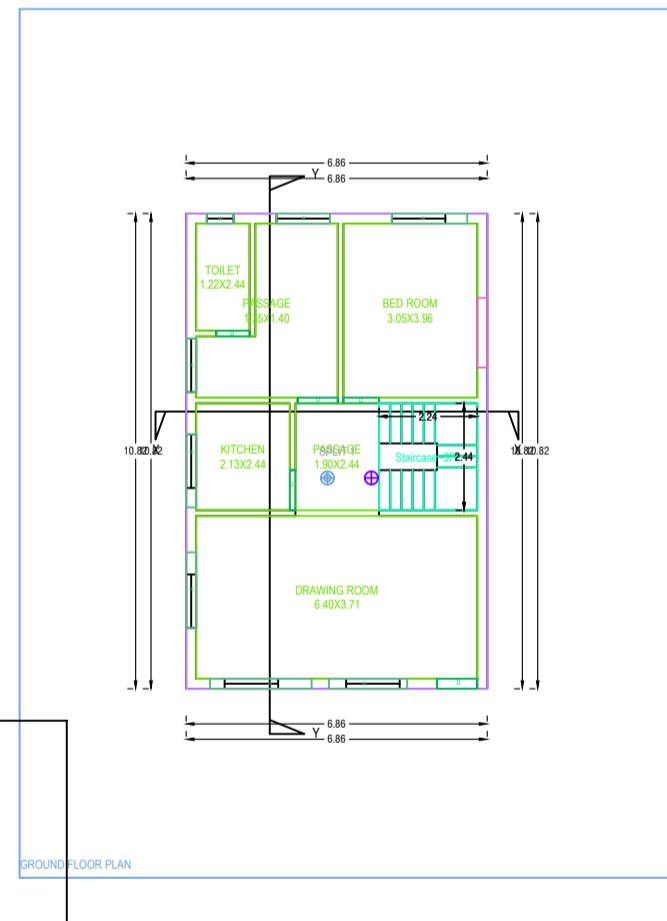
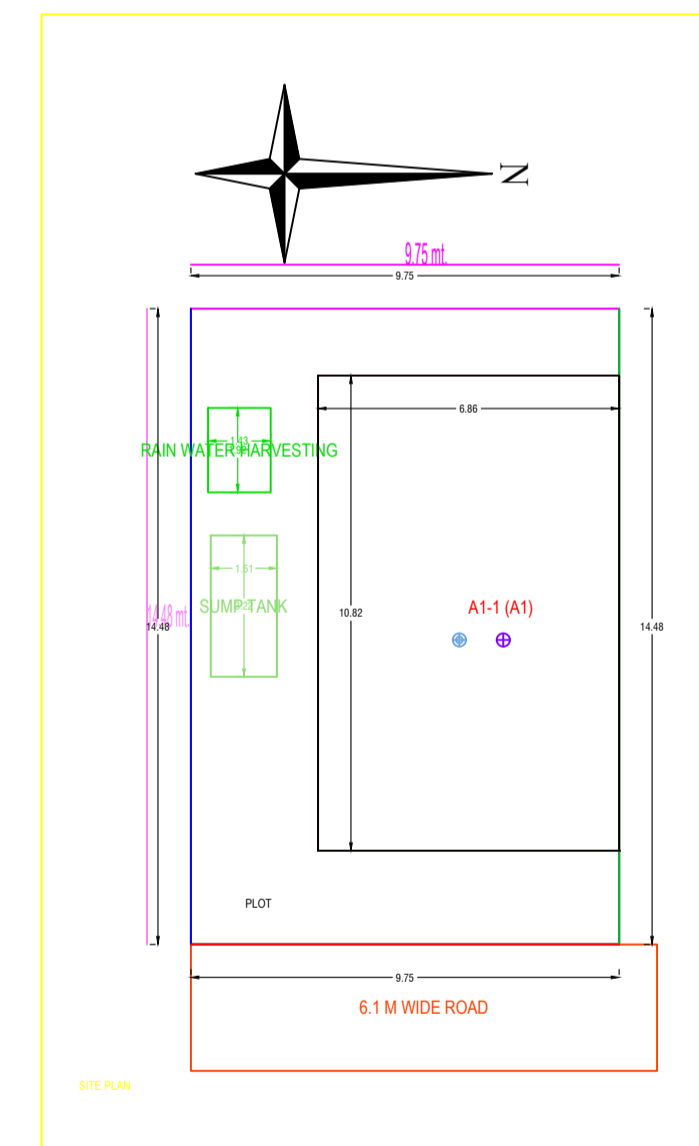
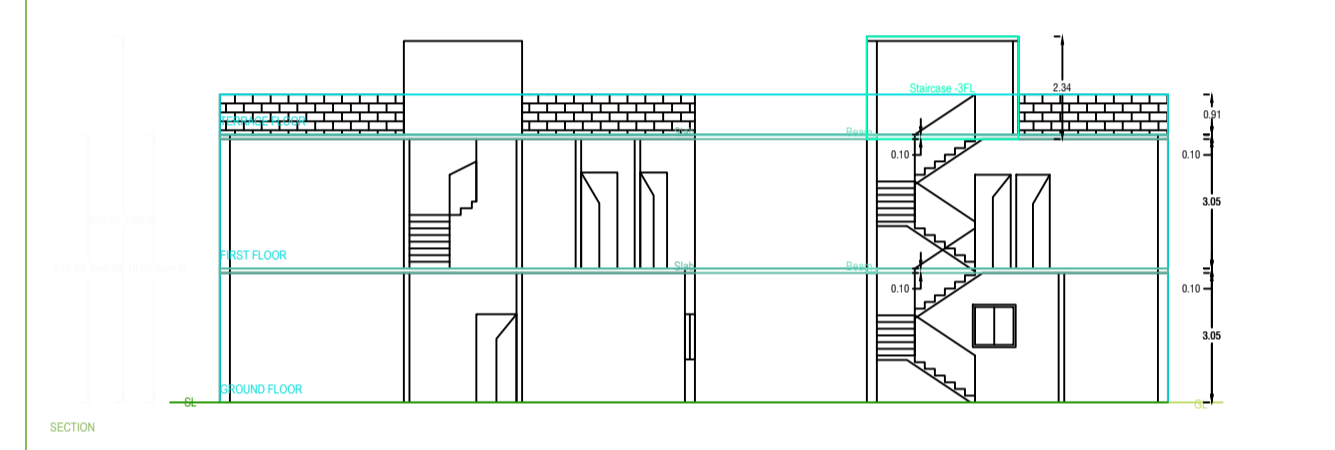
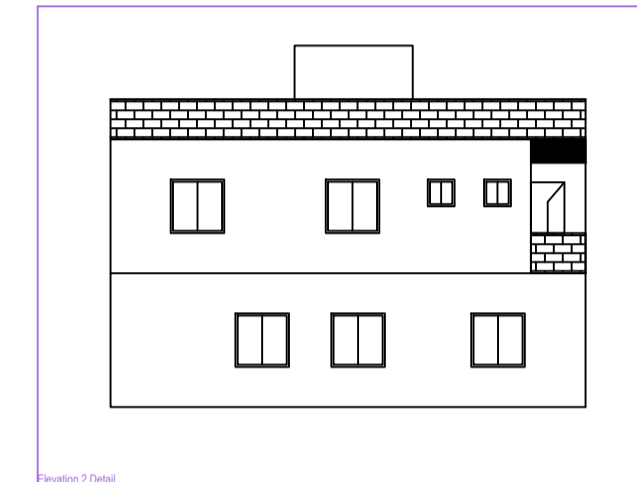
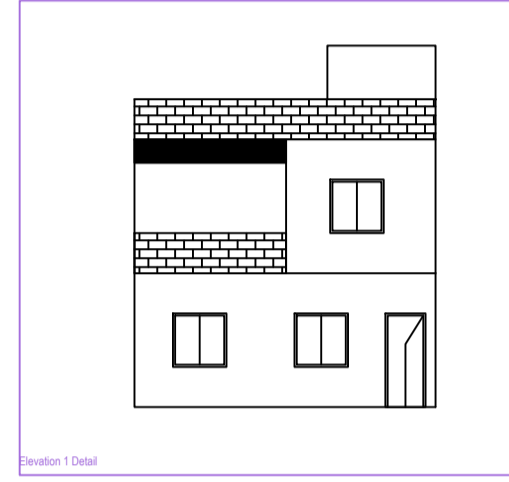
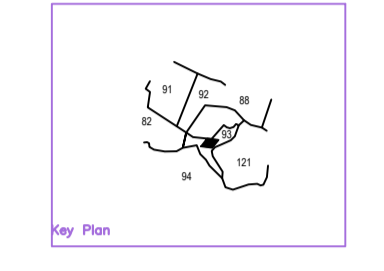
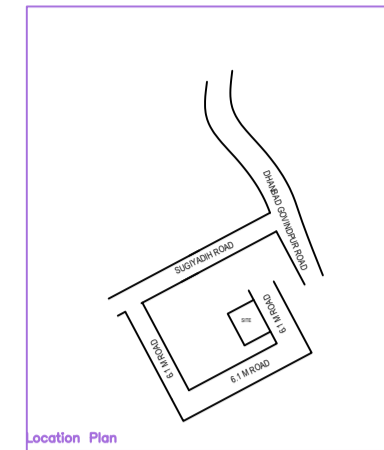
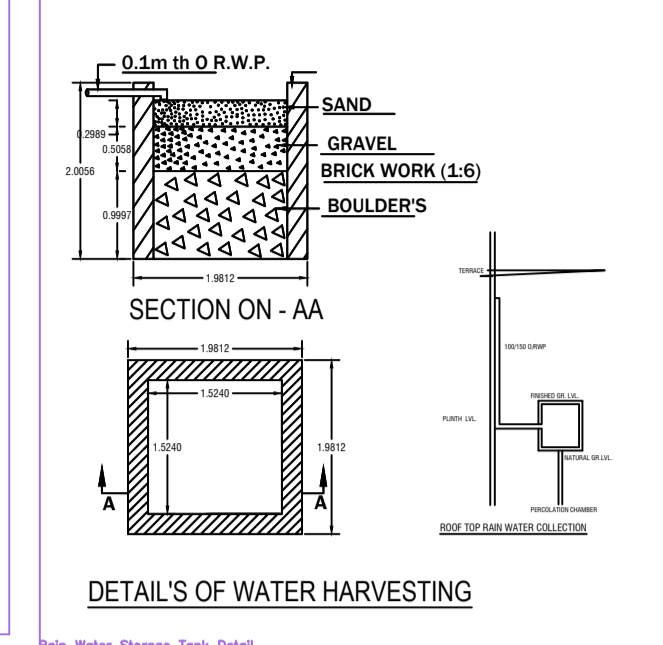
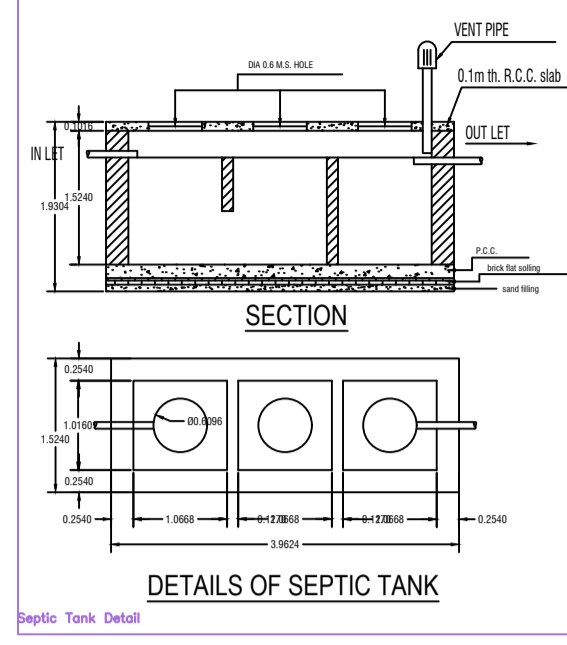
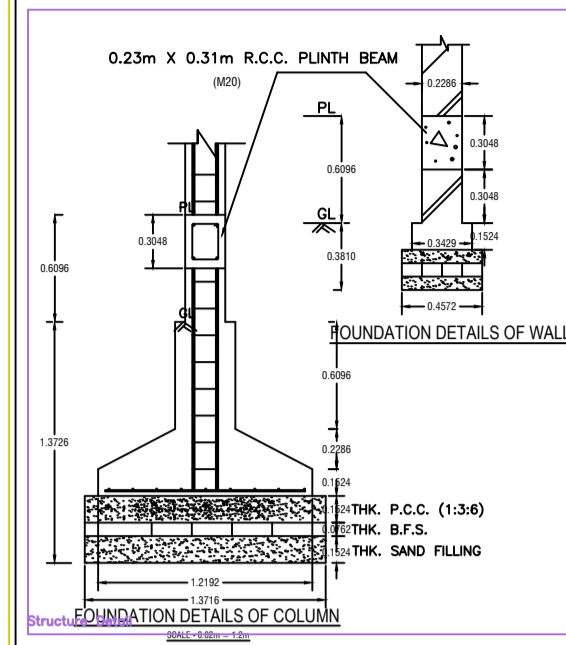

**BRIEF SPECIFICATION**

FOUNDATION - R.C.C. (1:1.5:3) Column footing foundation.  
 PLINTH - 12"th R.C.C. (1:1.5:3) all round on plinth level.  
 FLOORING - 1.5"th Marble flooring over 3"th P.C.C. (1:3:6).  
 SUPER STRUCTURE - First class brick work in cement mortar (1:6).  
 SLAB,BEAM, stairs & LINTEL - All R.C.C. work (1:1.5:3).  
 WOOD WORK - All door & window frames of sal wood  
 PLASTERING - 12mm cement plaster (1:6) both side.

**SCHEDULE**

D1 - 1.07 X 2.13	W - 0.9 x 1.22
D2 - 0.9 X 2.13	W1 - 1.22 x 1.22
D3 - 0.76 x 2.13	W2 - 1.5 x 1.22
C6 - 1.22 x 2.13	V - 0.61 x 0.61

**TITLE OF DRAWING**  
 PROPOSED RESIDENTIAL BUILDING OF 1) SHRAVAN KUMAR BELDAR S/O LATE HARI BELDAR 2) UMIRLA DEVI W/O SHRAVAN KUMAR BELDAR OF PTRAKULHII DHANBAD ON MOUZA - PATRAKULHI NO. 46, OLD KHATA NO. - 123, NEW KHATA NO. - 25, OLD PLOT NO. - 429, 430, NEW PLOT NO. 414 IN THE DISTRICT OF DHANBAD, JHARKHAND

**SIG. OF OWNER**

**SIG. OF ENGINEER**

**Building A1 (A1)**

Floor Name	Total Built Up Area (Sq.M)	Proposed FAR Area (Sq.M)	Total FAR Area (Sq.M)	Tree (No.)
Ground Floor	74.21	74.21	74.21	01
First Floor	74.21	74.21	74.21	02
Terrace Floor	3.99	3.99	3.99	02
Total	152.41	152.41	152.41	05

**SCHEDULE OF JOINERY:**

FLOORING NAME	NAME	LENGTH	HEIGHT	NO.
AT (A1)	D	0.76	2.13	04
AT (A1)	D	0.81	2.13	03
AT (A1)	D	0.95	2.13	06
Total				13

**SCHEDULE OF JOINERY:**

FLOORING NAME	NAME	LENGTH	HEIGHT	NO.
AT (A1)	W	0.61	1.22	02
AT (A1)	W	1.22	1.22	02
AT (A1)	W	1.66	1.22	01
AT (A1)	W	1.22	1.22	02
AT (A1)	W	1.76	1.22	01
AT (A1)	W	1.79	1.22	01
AT (A1)	W	1.83	1.22	01
AT (A1)	W	1.89	1.22	01
AT (A1)	W	1.99	1.22	01
AT (A1)	W	2.13	1.22	01
AT (A1)	W	2.21	1.22	01
Total				15

**UNBDA Table for Building A1 (A1)**

FLOOR	TYPE	Name	UNBDA Type	UNBDA Area	Cover Area	No. of Roofs	No. of Terrace
FLOOR PLAN	SPLIT 1	FLAT	FLAT	148.42	147.92	4	1
TERRACE	-	-	-	148.42	147.92	13	1

**AREA STATEMENT**

DESCRIPTION	AREA (Sq.M)
Plot Area	147.21
Area of Plot (Marginal)	147.21
Net Plot Area (Less FAR Area)	147.21
Balance Net Plot Area (Less FAR Area)	147.21
Net Area for Coverage (Net Plot Area)	147.21
Net Area for FAR (Net Plot Area)	147.21
Proposed Coverage Area (25.5%)	37.54
Net Coverage Area (25.5%)	37.54

**COLOR INDEX**

Color	Meaning
Black	Plot Boundary
Red	Abutting Road
Green	Proposed Work (Coverage Area)
Blue	Existing (To be retained)
Yellow	Existing (To be demolished)

**MARGIN DETAIL:**

Building Wing	Road Name	Front Margin	Rear Margin	Side Margin	Side Margin
AT (A1)	6.1 M WIDE ROAD	2.13	1.52	2.90	0.00

**FAR & Terment Details (Table 4c-1)**

Building	No. of Same Bldg	Total Built Up Area (Sq.M)	Proposed FAR Area (Sq.M)	Total FAR Area (Sq.M)	Tree (No.)
AT (A1)	1	148.42	148.42	148.42	05
Grand Total	1	148.42	148.42	148.42	05