

Proposal Basic Information

Proposal File No.	DMC/BP/0112/W30/2023
Owner Name	SMT GYANTI DEVI
Khata No	5(OLD), 5(NEW)
Plot No	833(OLD), 817(NEW)
Village Name	Duhatand
Use	Residential
SubUse	Bungalow/ Dwelling / Non Apartment

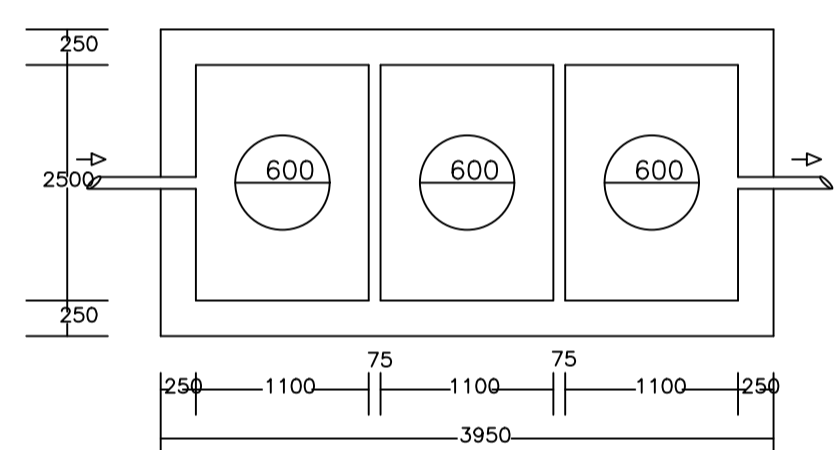

PLAN OF SEPTIC TANK

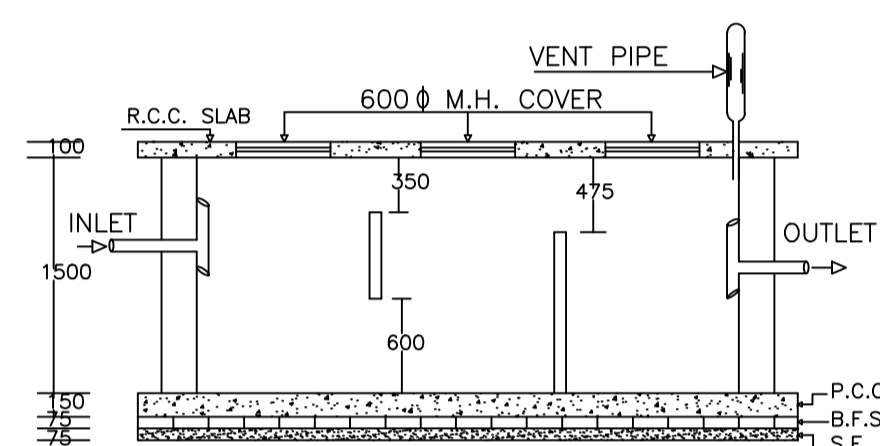
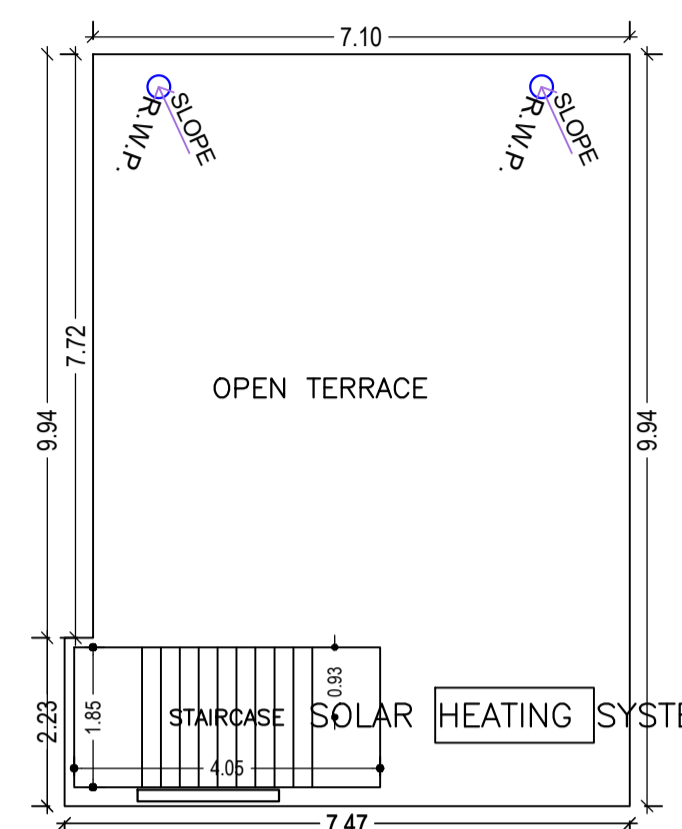
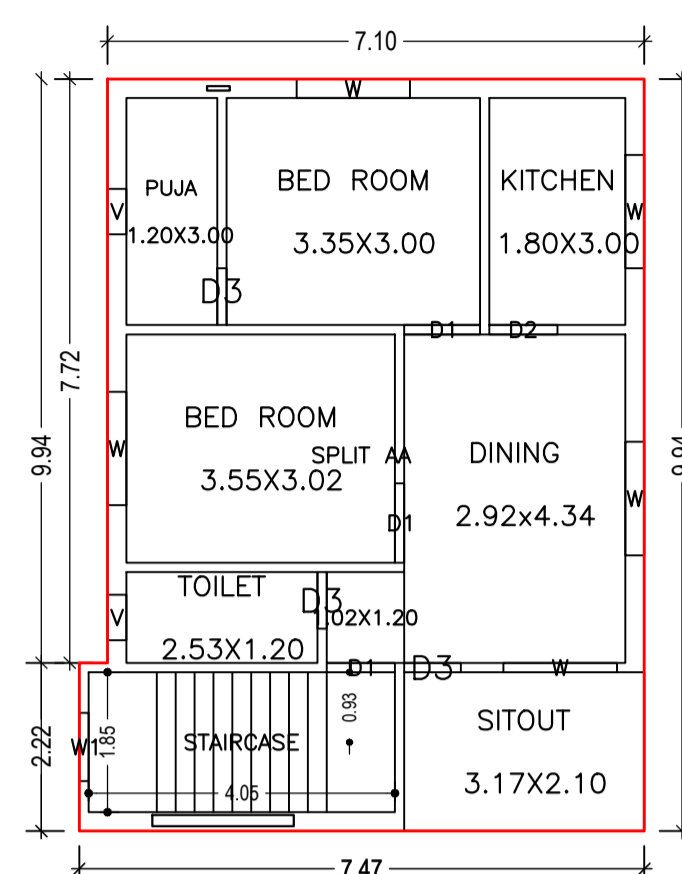
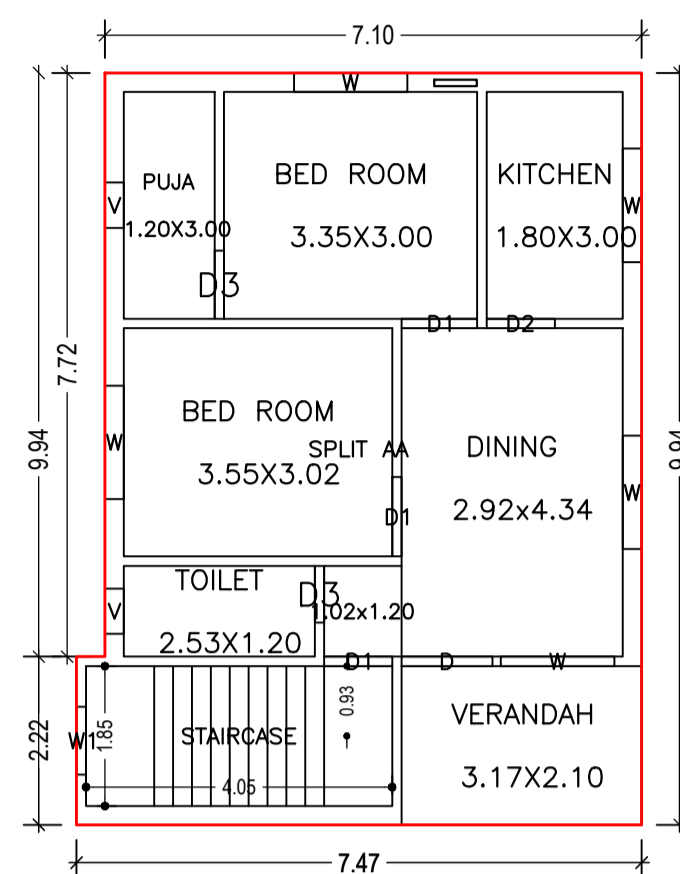
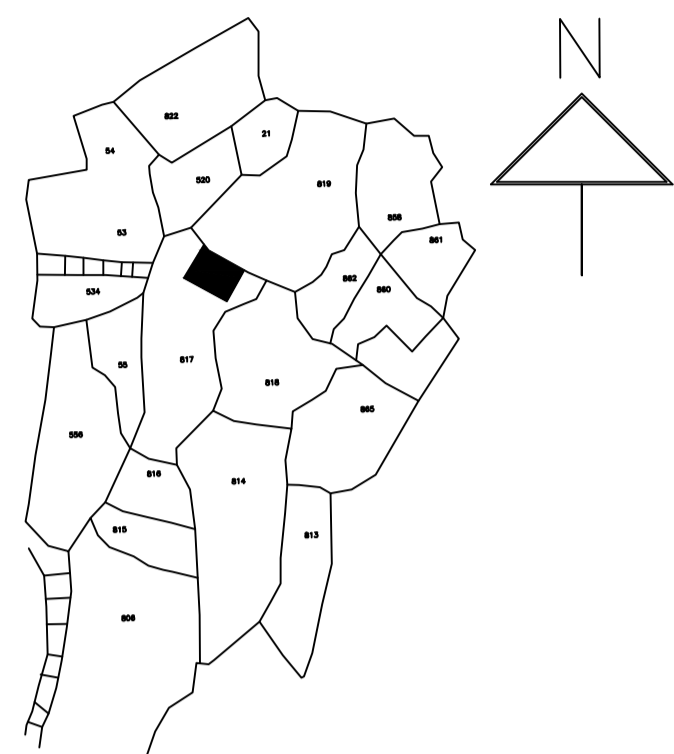
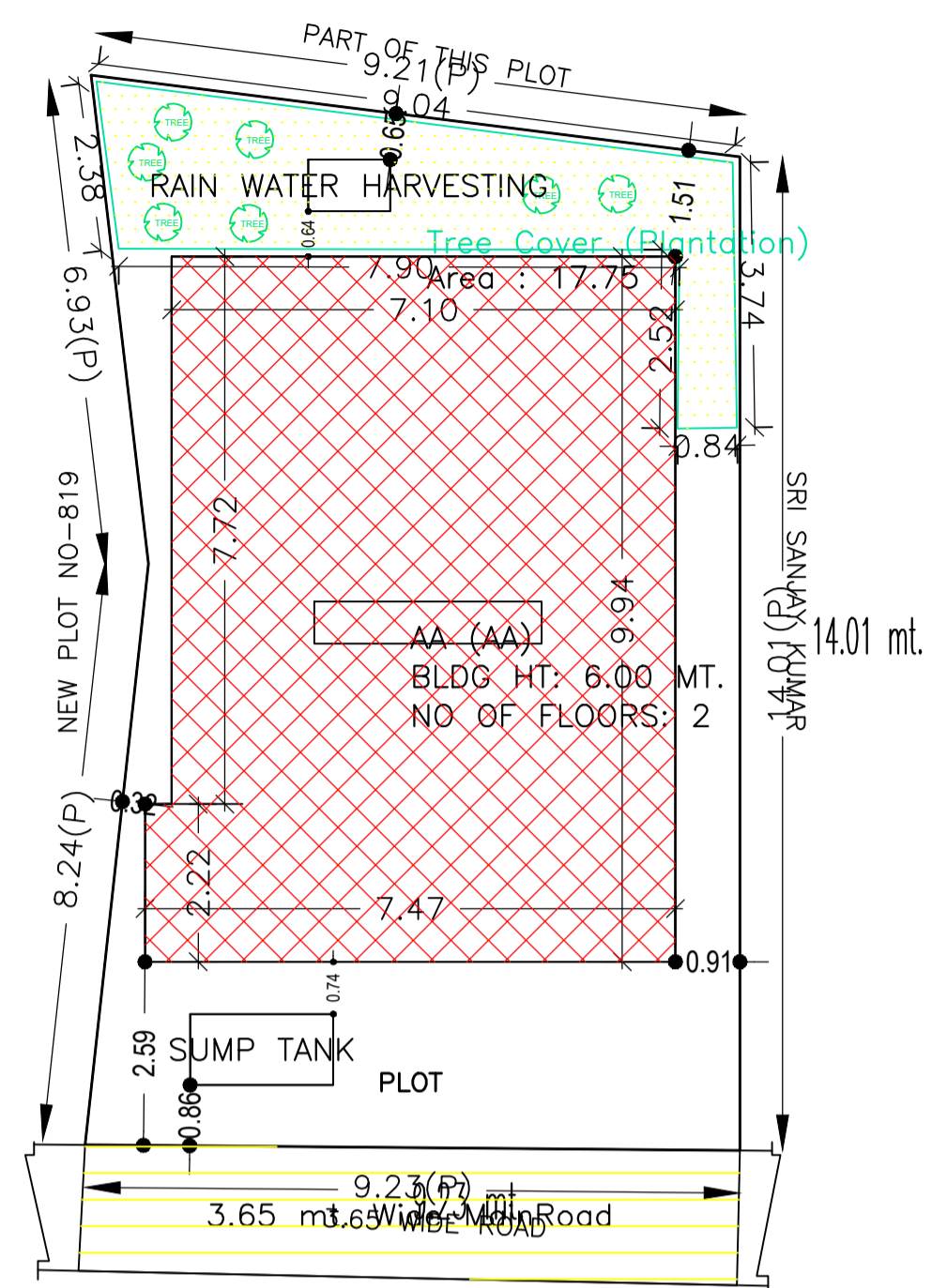
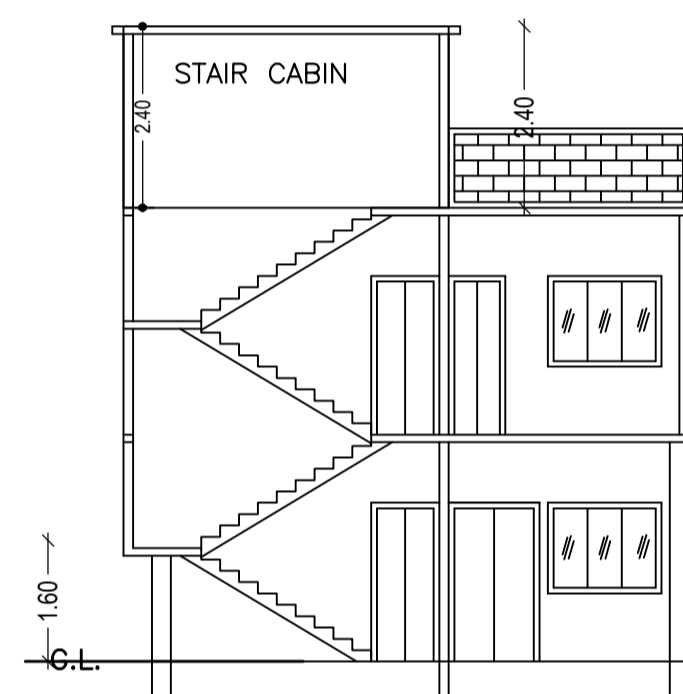

SECTION ON X-X

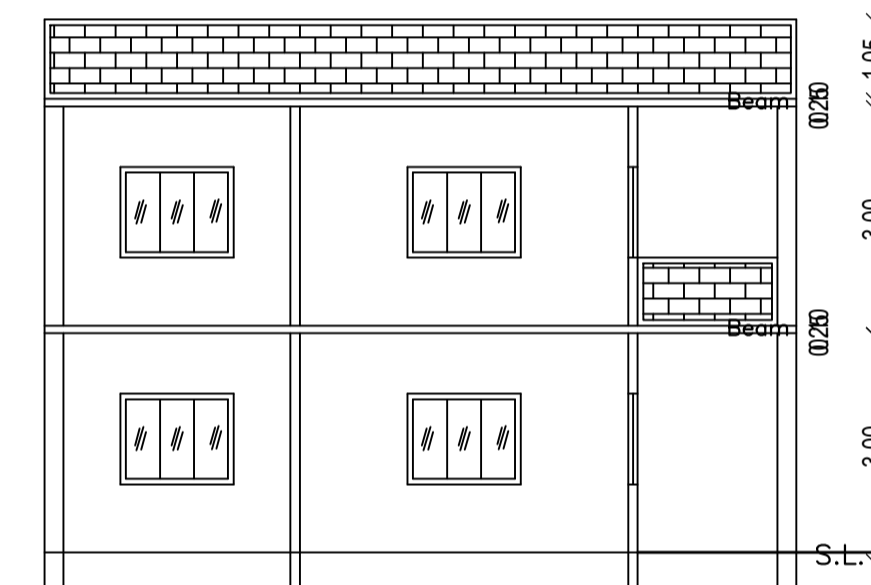

SECTION ON Y-Y

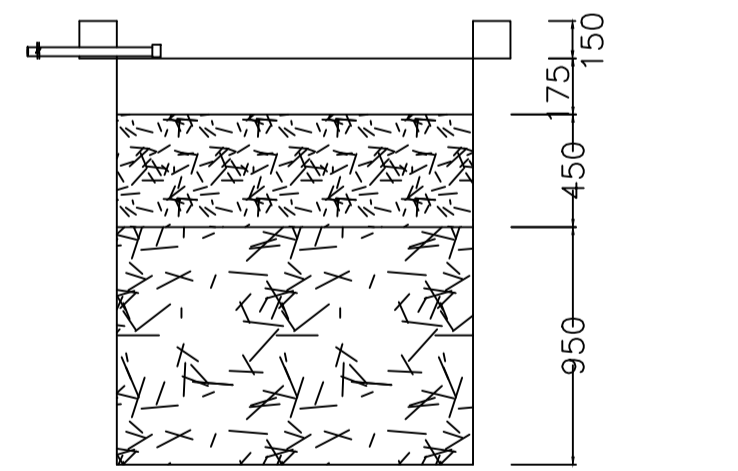

SECTION AT Y-Y

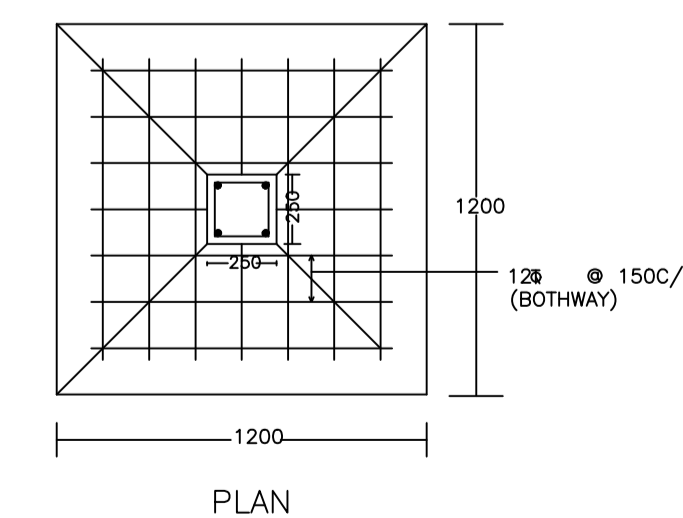
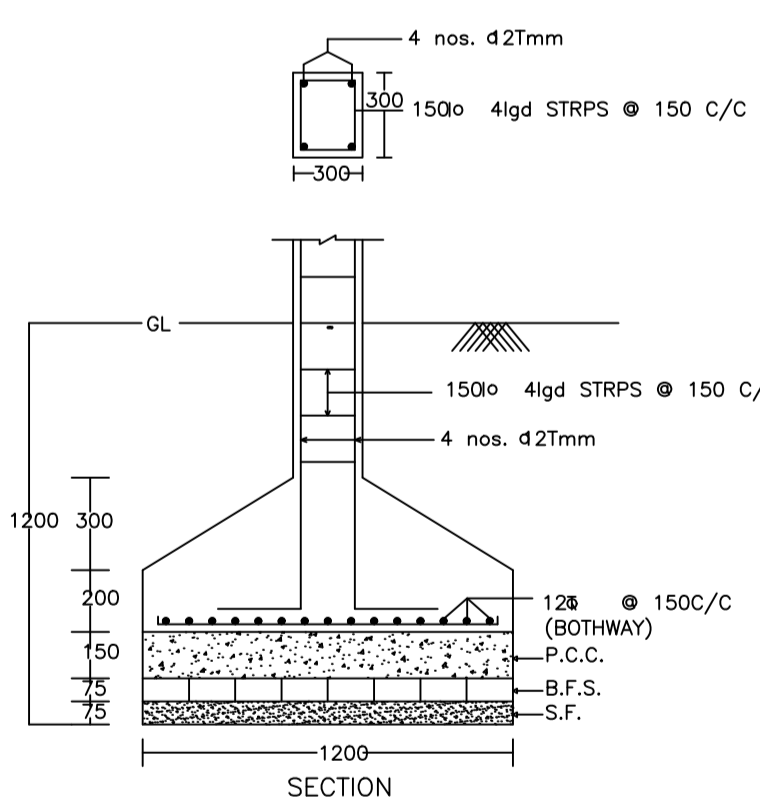

PLAN OF RECHARGE WELL

WATER HARVESTING

DETAIL OF COLUMNS



FRONT ELEVATION

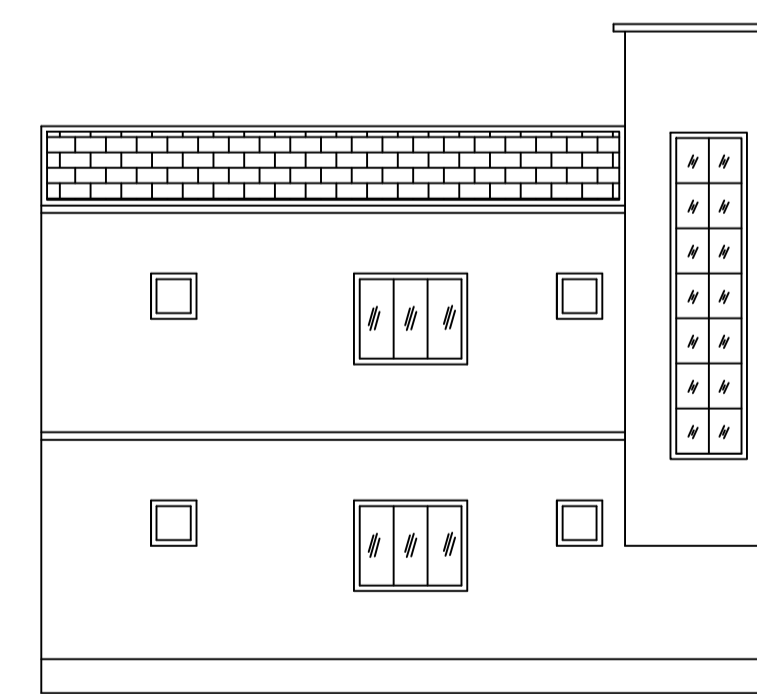

LEFT SIDE ELEVATION

AREA STATEMENT	VERSION NO.: 1.0.66	SQ.MT.
DHANBAD MUNICIPAL CORPORATION	VERSION DATE: 16/10/2020	
PROJECT DETAIL:		
Region: JHARKHAND URBAN LOCAL BODIES	Plot Use: Residential	
District: DHANBAD	Plot SubUse: Bungalow/ Dwelling / Non Apartment	
Authority: DHANBAD MUNICIPAL CORPORATION	PlotNearbyReligiousStructure: NA	
Inward No: DMC/BP/0112/W30/2023	Plot/SubPlot No: 833(OLD), 817(NEW)	
Application Type: General Proposal	North: Plot No. - NEW PLOT NO-819	
Project Type: Building Permission	South: Plot No. - SRI SANJAY KUMAR	
Nature of Development: New	East: Plot No. - PART OF THIS PLOT	
Location of Development Area: Old Area	West: Road Width - 3.65	
AREA DETAILS:		
AREA OF PLOT (Minimum)	(A)	127.28
NET AREA OF PLOT(Gross Plot Area - Deduction from Gross Plot area)	(A-Deductions)	127.28
Deduction for Balance Plot Area(from Gross Plot Area)		
Common Plot		17.75
Total		17.75
BALANCE AREA OF PLOT(Net Plot Area - Recreational/Amenity space)	(A-Deductions)	109.52
PLOT AREA FOR COVERAGE(Net Plot Area)	(A-Deductions)	127.28
Plot Area for FAR (Net Plot Area + Road Widening Area)	(A-Deductions)	127.28
COVERAGE CHECK		
Permissible Coverage area (70.00 %)		89.10
Proposed Coverage Area (56.13 %)		71.44
Total Prop. Coverage Area (56.13 %)		71.44
Balance coverage area (13.88 %)		17.66
FAR CHECK		
Perm. FAR Area (1.500)		190.92
Total Perm. FAR area		190.92
Residential FAR		142.87
Proposed FAR Area		142.87
Total Proposed FAR Area		142.87
Consumed FAR (Factor)		1.12
Balance FAR Area		48.05
BUILT UP AREA CHECK		
Total Proposed BuiltUp Area		142.88
ARCHITECT (Regd)	SANJEEV KUMAR RAY	
ENGINEER (Regd)		
SUPERVISOR (Regd)		
OWNER (Regd)	SMT GYANTI DEVI	
DEVELOPMENT AUTHORITY LOCAL BODY		

COLOR INDEX	
PLOT BOUNDARY	Black
ABUTTING ROAD	Green
PROPOSED CONSTRUCTION	Red
COMMON PLOT	Yellow
ROAD WIDENING AREA	Blue
EXISTING (To be retained)	Light Blue
EXISTING (To be demolished)	Dark Blue

Buildingwise Floor FAR Details

Floor Name	Building Name AA (AA)		Total	
	Proposed Built Up Area (Sq.mt.)	Proposed FAR Area (Sq.mt.)	Total Proposed Built Up Area (Sq.mt.)	Total FAR Area (Sq.mt.)
Ground Floor	71.44	71.44	71.44	71.44
First Floor	71.44	71.44	71.44	71.44
Terrace Floor	0.00	0.00	0.00	0.00
Total :	142.88	142.88	142.88	142.88

Building USE/SUBUSE Details

Building Name	Building Use	Building SubUse	Building Structure
AA (AA)	Residential	Bungalow/ Dwelling / Non Apartment	Non-Highrise

SCHEDULE OF DOOR:

BUILDING NAME	NAME	LENGTH	HEIGHT	NOS
AA (AA)	D3	0.75	2.10	04
AA (AA)	D2	0.90	2.10	02
AA (AA)	D1	0.90	2.10	02
AA (AA)	D3	0.90	2.10	01
AA (AA)	D3	1.00	2.10	02
AA (AA)	D1	1.05	2.10	02
AA (AA)	D	1.20	2.10	01

SCHEDULE OF WINDOW/VENTILATION:

BUILDING NAME	NAME	LENGTH	HEIGHT	NOS
AA (AA)	V	0.60	1.20	04
AA (AA)	W1	0.90	1.20	02
AA (AA)	W	1.50	1.20	10

Building :AA (AA)

Floor Name	Total Built Up Area (Sq.mt.)	Proposed FAR Area (Sq.mt.) Resi.	Total FAR Area (Sq.mt.)	Total Consumed Additional FAR Area (Sq.mt.)	Tnmt (No.)
Ground Floor	71.44	71.44	71.44	71.44	01
First Floor	71.44	71.44	71.44	71.44	00
Terrace Floor	0.00	0.00	0.00	0.00	00
Total :	142.88	142.88	142.88	142.88	01
Total Number of Same Buildings	1				
Total :	142.88	142.88	142.88	142.88	01

UnitBUA Table for Building :AA (AA)

FLOOR	Name	UnitBUA Type	UnitBUA Area	Carpet Area	No. of Rooms	No. of Tenement
GROUND FLOOR	SPLIT AA	FLAT	142.87	142.53	7	1
FIRST FLOOR	SPLIT AA	FLAT	0.00	0.00	7	0
Total :	-	-	142.87	142.53	14	1

FAR & Tenement Details (Table 4c-1)

Building	No. of Same Bldg	Total Built Up Area (Sq.mt.)	Proposed FAR Area (Sq.mt.) Resi.	Total FAR Area (Sq.mt.)	Total Consumed Additional FAR Area (Sq.mt.)	Tnmt (No.)
AA (AA)	1	142.88	142.88	142.88	142.88	01
Grand Total :	1	142.88	142.88	142.88	142.88	01

LTP NAME AND SIGNATURE	STRUCTURAL ENG'S NAME AND SIGNATURE	BUILDER NAME AND SIGNATURE	DIGITAL SIGNATURE
SANJEEV KUMAR RAY DMC/ENG/0001/2019			