

Proposal Basic Information

Proposal File No.	DMC/BP/0279/W20/2023
Owner Name	SWEETY GUPTA
Khata No	57
Plot No	3036
Village Name	Dhaiya
Use	Residential
SubUse	Bungalow/ Dwelling / Non Apartment

AREA STATEMENT

Version No.	1.0.66	
Version Date	16/10/2020	
Region	JHARKHAND URBAN LOCAL BODIES	
District	DHANBAD	
Authority	DHANBAD MUNICIPAL CORPORATION	
Inward No.	DMC/BP/0279/W20/2023	
Application Type	General Proposal	
Project Type	Building Permission	
Nature of Development	New	
Location of Development Area	Old Area	
Area	West: Plot No. - PART OF THIS PLOT	
Plot Use	Residential	
Plot SubUse	Bungalow/ Dwelling / Non Apartment	
Plot Nearby/Religious Structure	NA	
Plot/SubPlot No.	3036	
North: Plot No. - PART OF THIS PLOT		
South: Road Width - 3.6		
East: Road Width - 3.6		
West: Plot No. - PART OF THIS PLOT		
AREA OF PLOT (Minimum)	(A)	129.77
NET AREA OF PLOT (Gross Plot Area - Deduction from Gross Plot area)	(A-Deductions)	129.77
Deduction for Balance Plot Area (from Gross Plot Area)		
Common Plot		19.12
Total		19.12
BALANCE AREA OF PLOT (Net Plot Area - Recreational/Amenity space)	(A-Deductions)	110.65
PLOT AREA FOR COVERAGE (Net Plot Area)	(A-Deductions)	129.77
Plot Area for FAR (Net Plot Area + Road Widening Area)	(A-Deductions)	129.77
COVERAGES CHECK		
Permissible Coverage area (70.00 %)		90.84
Proposed Coverage Area (41.94 %)		54.43
Total Prop. Coverage Area (41.94 %)		54.43
Balance coverage area (28.06 %)		36.41
FAR CHECK		
Perm. FAR Area (1.500)		194.65
Total Perm. FAR area		194.65
Residential FAR		168.61
Proposed FAR Area		168.61
Total Proposed FAR Area		168.61
Consumed FAR (Factor)		1.30
Balance FAR Area		26.04
BUILT UP AREA CHECK		
Total Proposed BuiltUp Area		190.48
ARCHITECT (Regd)		RAJEEV RANJAN SINGH
ENGINEER (Regd)		
SUPERVISOR (Regd)		
OWNER (Regd)		SWEETY GUPTA
DEVELOPMENT AUTHORITY		LOCAL BODY

Building USE/SUBUSE Details

Building Name	Building Use	Building SubUse	Building Structure
A (SWEETY GUPTA)	Residential	Bungalow/ Dwelling / Non Apartment	Non-Highrise

SCHEDULE OF DOOR:

BUILDING NAME	NAME	LENGTH	HEIGHT	NOS
A (SWEETY GUPTA)	D	0.65	2.10	03
A (SWEETY GUPTA)	D	0.76	2.10	03
A (SWEETY GUPTA)	D	0.91	2.10	02
A (SWEETY GUPTA)	D	0.95	2.10	03
A (SWEETY GUPTA)	D	1.06	2.10	03

SCHEDULE OF WINDOW/VENTILATION:

BUILDING NAME	NAME	LENGTH	HEIGHT	NOS
A (SWEETY GUPTA)	W	0.89	1.20	01
A (SWEETY GUPTA)	W	0.96	1.20	02
A (SWEETY GUPTA)	W	1.36	1.20	01
A (SWEETY GUPTA)	W	1.52	1.20	02
A (SWEETY GUPTA)	W	1.71	1.20	01
A (SWEETY GUPTA)	W	2.08	1.20	01
A (SWEETY GUPTA)	W	2.11	1.20	01
A (SWEETY GUPTA)	W	2.26	1.20	01
A (SWEETY GUPTA)	W	2.29	1.20	02
A (SWEETY GUPTA)	W	2.31	1.20	01
A (SWEETY GUPTA)	W	2.33	1.20	03
A (SWEETY GUPTA)	W	2.52	1.20	02
A (SWEETY GUPTA)	W	2.62	1.20	02
A (SWEETY GUPTA)	W	2.64	1.20	02
A (SWEETY GUPTA)	W	2.66	1.20	02

Building :A (SWEETY GUPTA)

Floor Name	Total Built Up Area (Sq.mt.)	Deductions (Area in Sq.mt.)	Proposed FAR Area (Sq.mt.)	Total FAR Area (Sq.mt.)	Total Consumed Additional FAR Area (Sq.mt.)	Trmt (No.)
Ground Floor	54.44	7.29	47.15	47.15	47.15	01
First Floor	68.02	7.29	60.73	60.73	60.73	00
Second Floor	68.02	7.29	60.73	60.73	60.73	00
Terrace Floor	0.00	0.00	0.00	0.00	0.00	00
Total	190.48	21.87	168.61	168.61	168.61	01
Total Number of Same Buildings	1					
Total	190.48	21.87	168.61	168.61	168.61	01

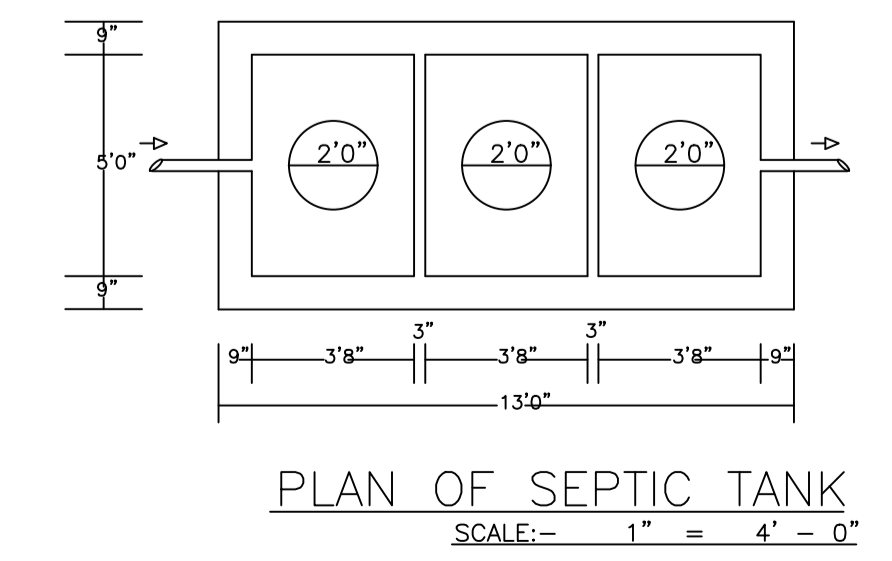
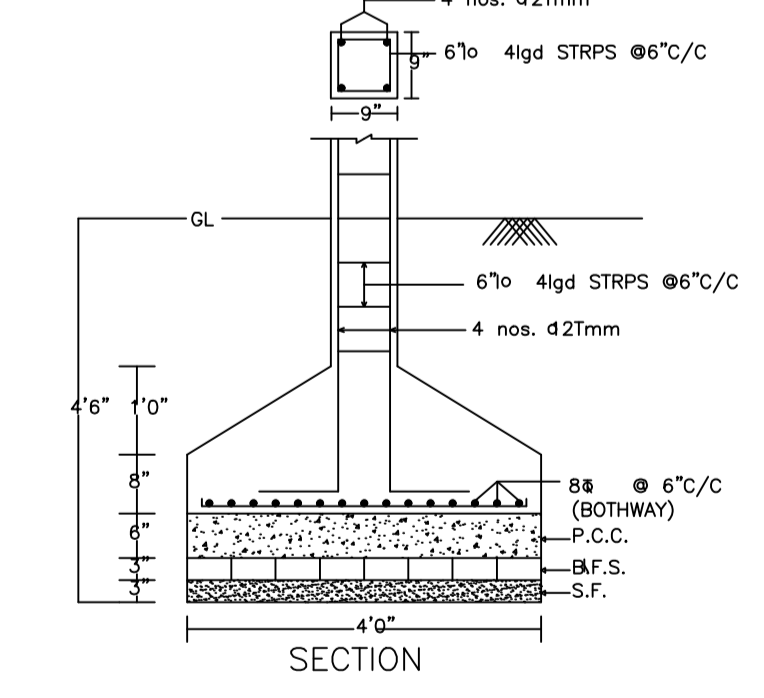
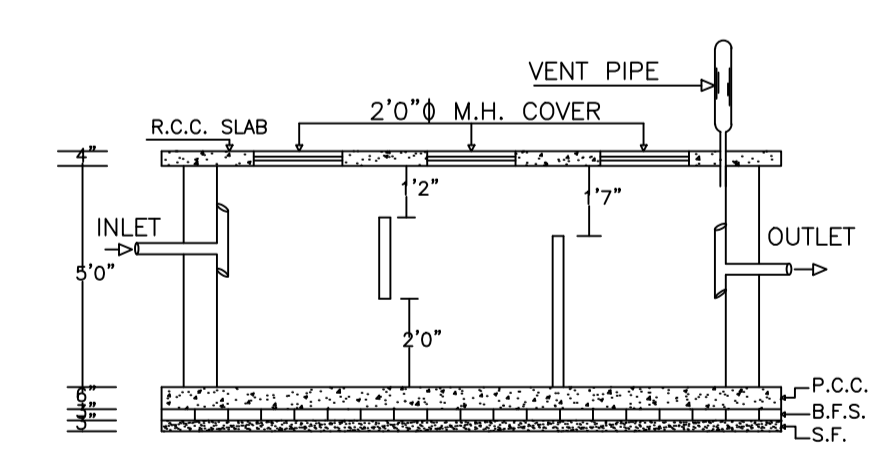
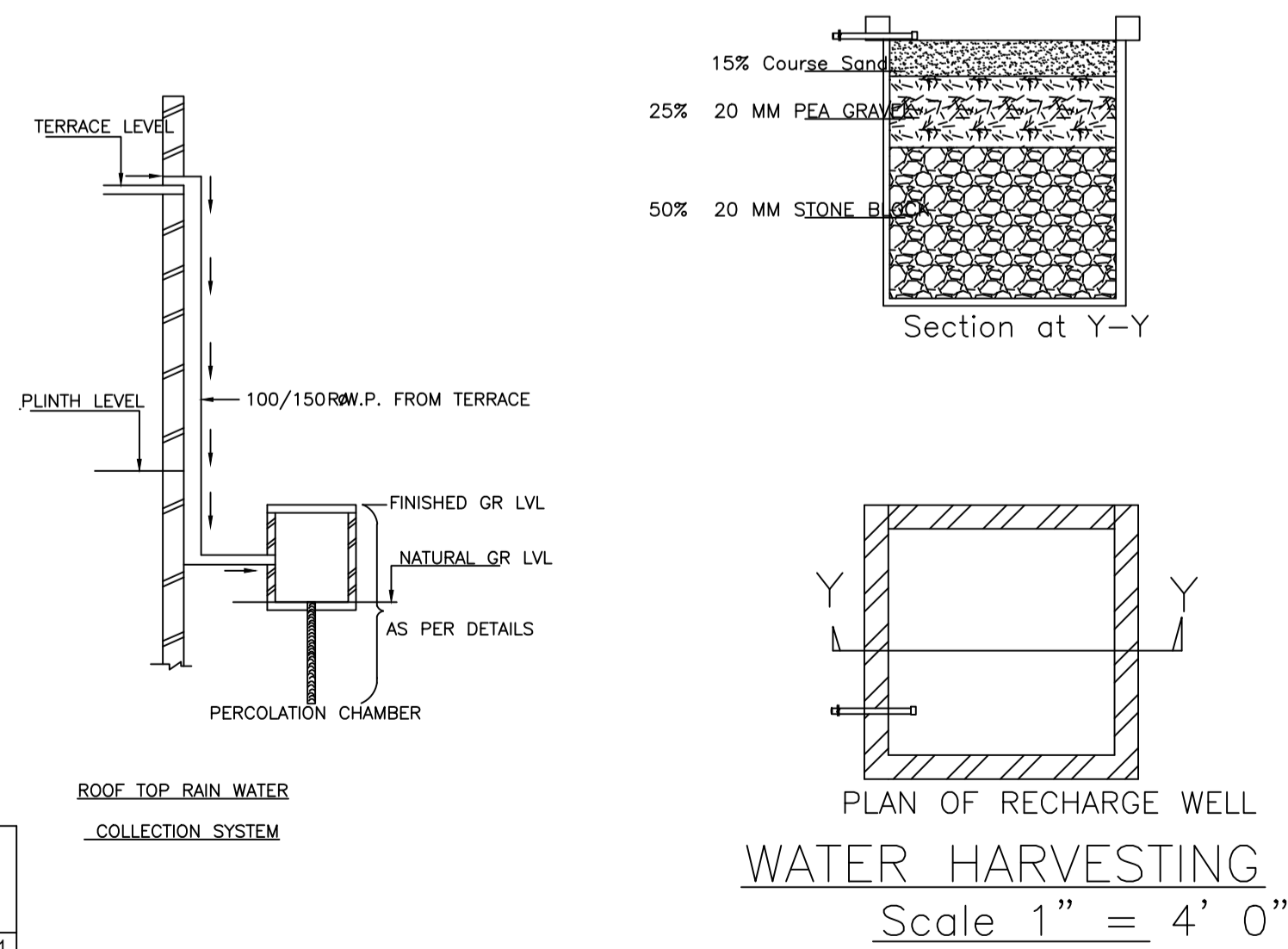

COLOR INDEX

PLOT BOUNDARY	Black
ABUTTING ROAD	Green
PROPOSED CONSTRUCTION	Red
COMMON PLOT	Yellow
ROAD WIDENING AREA	Blue
EXISTING (To be retained)	Orange
EXISTING (To be demolished)	Light Blue

Buildingwise Floor FAR Details

Floor Name	Building Name		Total	
	Proposed Built Up Area (Sq.mt.)	Proposed FAR Area (Sq.mt.)	Total Proposed Built Up Area (Sq.mt.)	Total FAR Area (Sq.mt.)
Ground Floor	54.44	47.15	54.44	47.15
First Floor	68.02	60.73	68.02	60.73
Second Floor	68.02	60.73	68.02	60.73
Terrace Floor	0.00	0.00	0.00	0.00
Total	190.48	168.61	190.48	168.61

UnitBUA Table for Building :A (SWEETY GUPTA)

FLOOR	Name	UnitBUA Type	UnitBUA Area	Carpet Area	No. of Rooms	No. of Tenement
TYPICAL - 1,	SPLIT A	FLAT	0.00	0.00	5	0
2 FLOOR PLAN	SPLIT A	FLAT	190.48	190.33	4	1
GROUND FLOOR PLAN	-	-	190.48	190.33	14	1
Total:						

FAR & Tenement Details (Table 4c-1)

Building	No. of Same Bldg	Total Built Up Area (Sq.mt.)	Deductions (Area in Sq.mt.)	Proposed FAR Area (Sq.mt.)	Total FAR Area (Sq.mt.)	Total Consumed Additional FAR Area (Sq.mt.)	Trmt (No.)
A (SWEETY GUPTA)	1	190.48	21.87	168.61	168.61	168.61	01
Grand Total :	1	190.48	21.87	168.61	168.61	168.61	01

LTP NAME AND SIGNATURE RAJEEV RANJAN SINGH DMC/ENG/0032/2017	STRUCTURAL ENG'S NAME AND SIGNATURE	BUILDER NAME AND SIGNATURE	DIGITAL SIGNATURE
--	-------------------------------------	----------------------------	-------------------

Proposal Basic Information	
Proposal File No.	DMC/BPI/0279/W20/2023
Owner Name	SWEETY GUPTA
Khata No	57
Plot No	3036
Village Name	Dhaiya
Use	Residential
SubUse	Bungalow/ Dwelling / Non Apartment

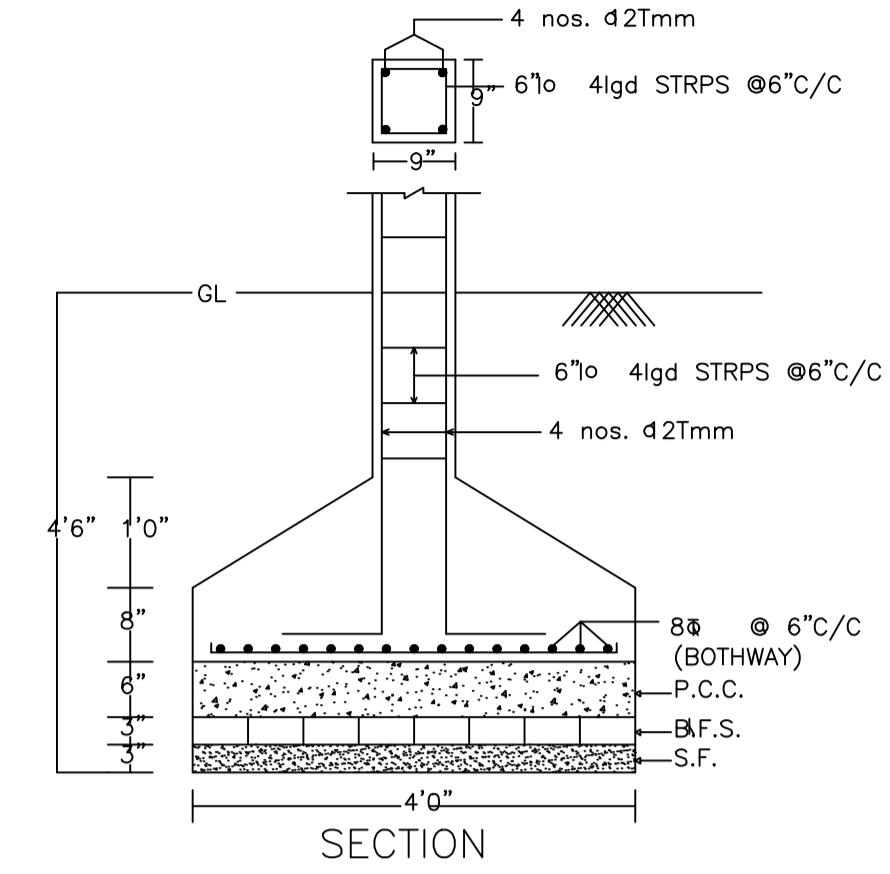
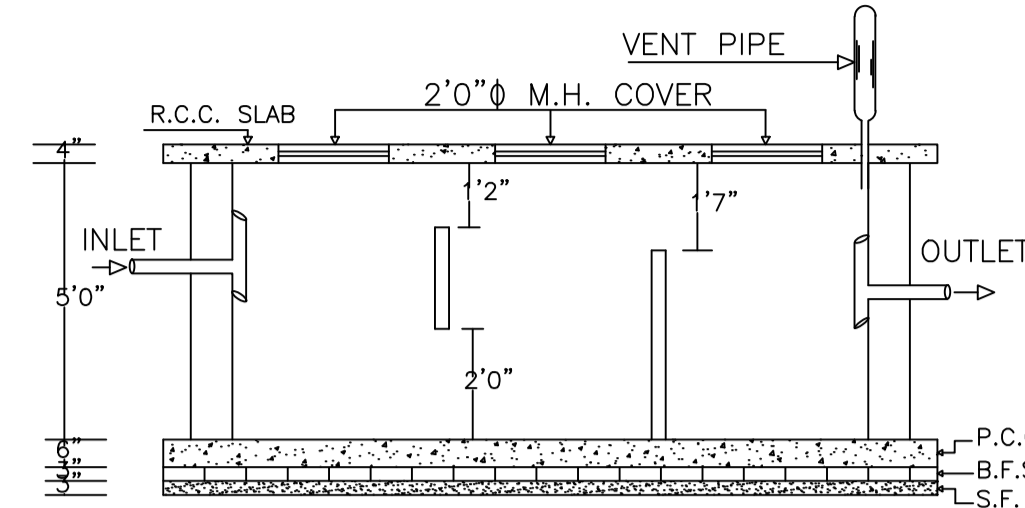
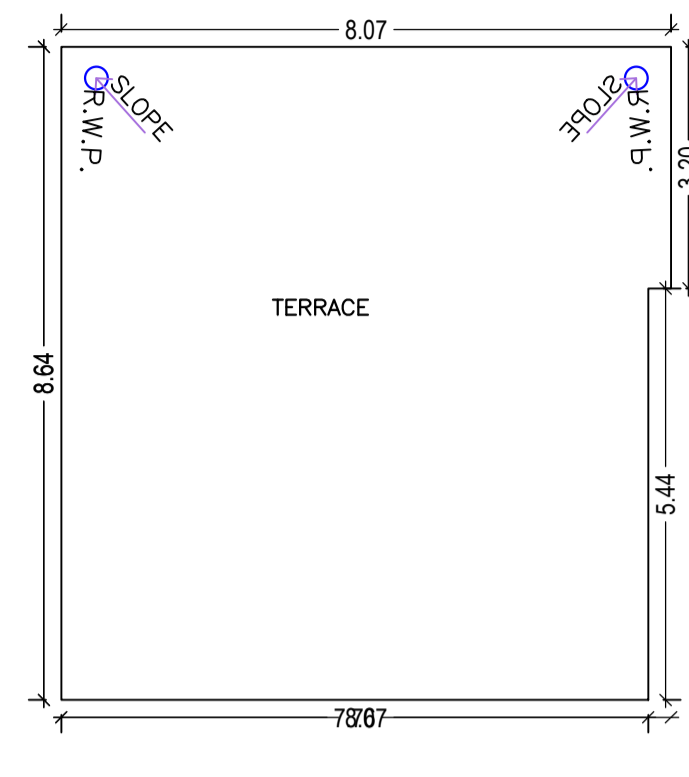
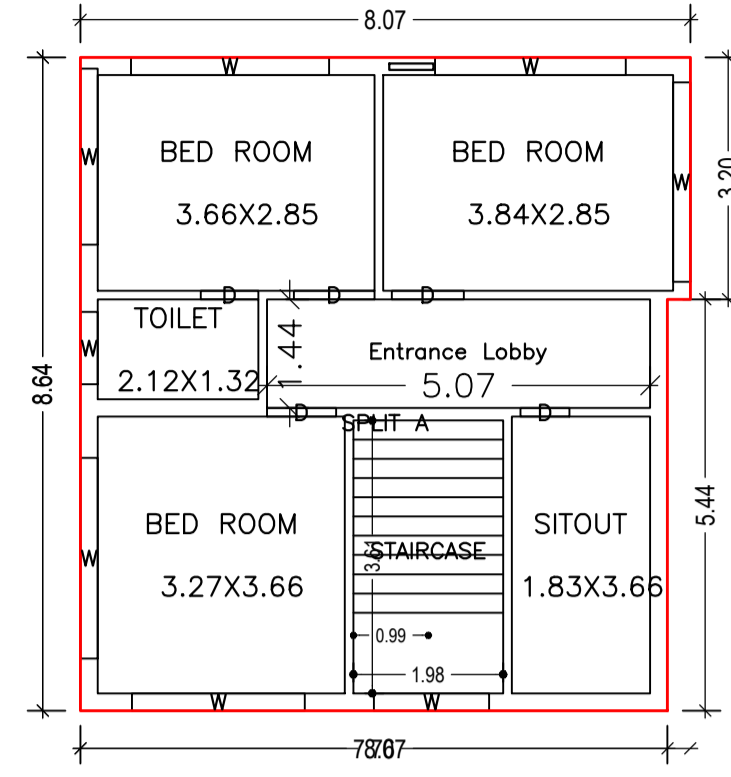
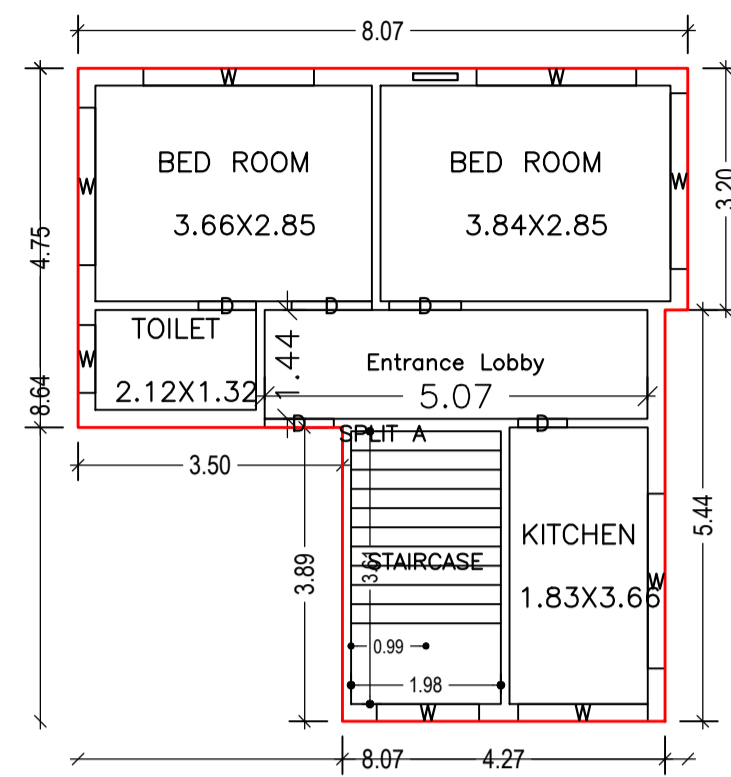

DETAIL OF COLUMNS

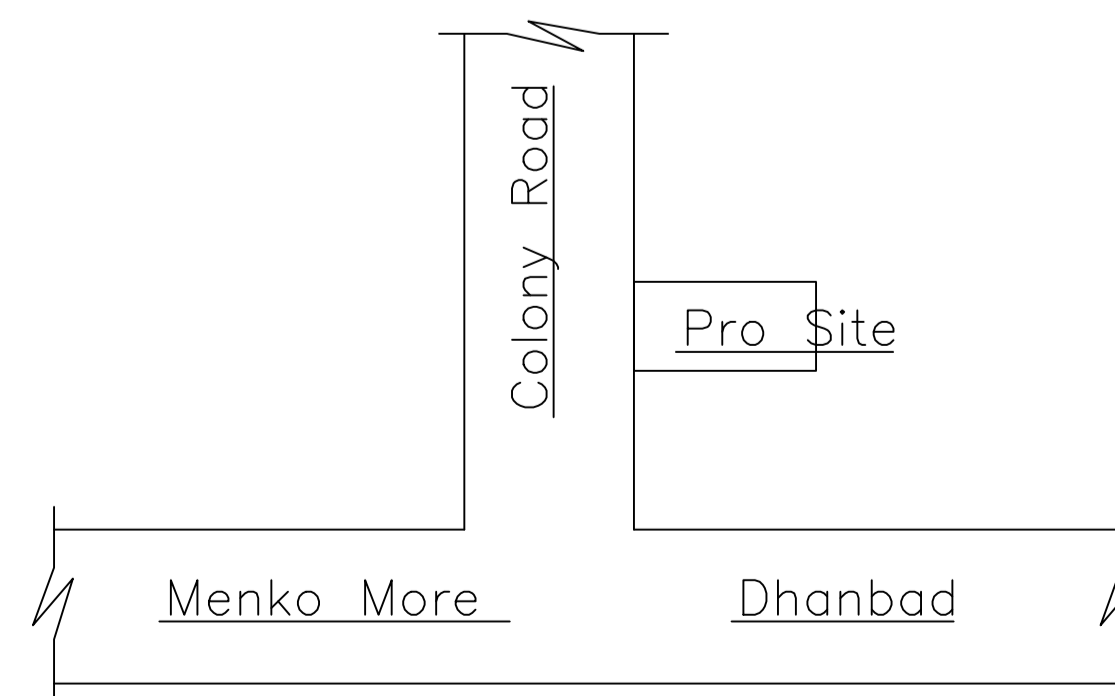
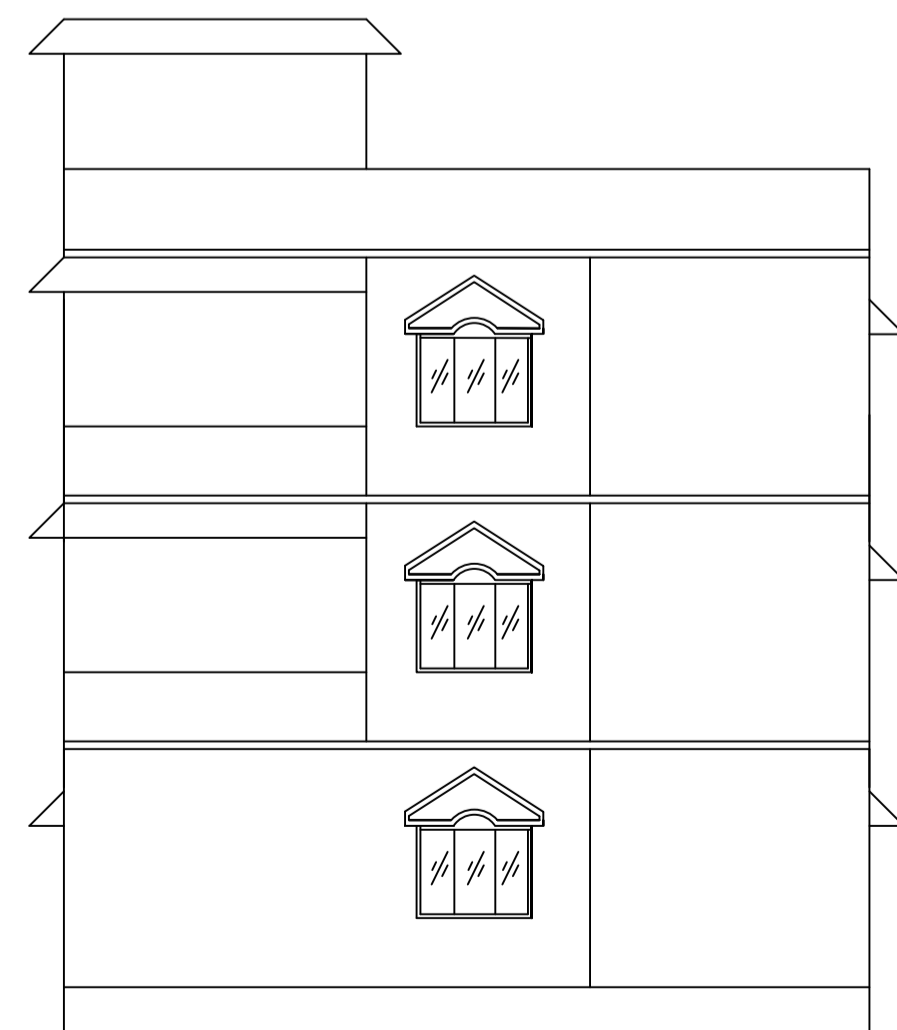
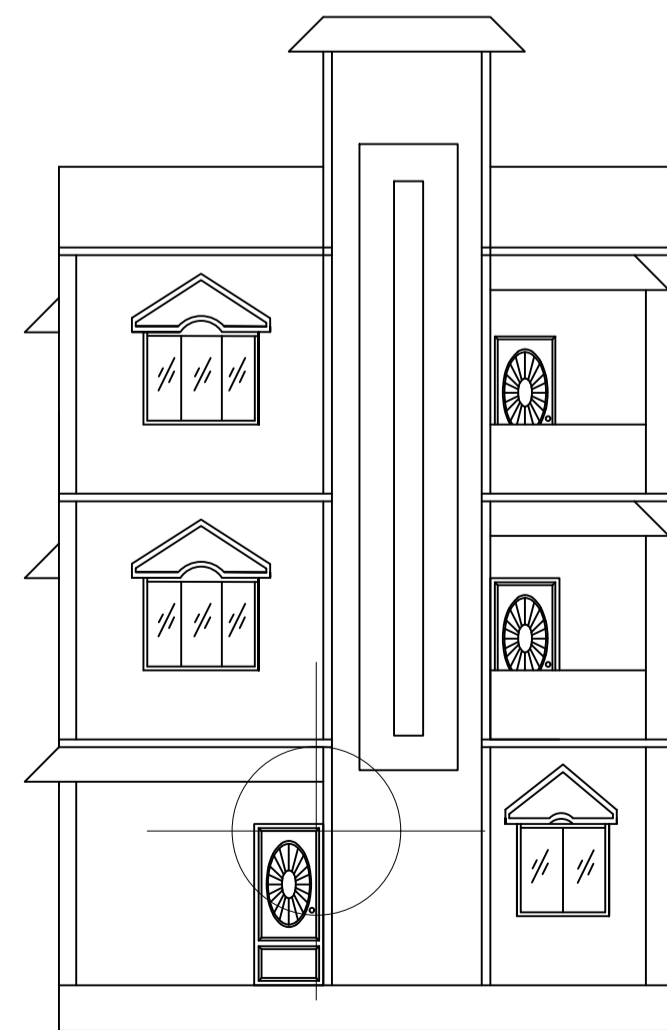
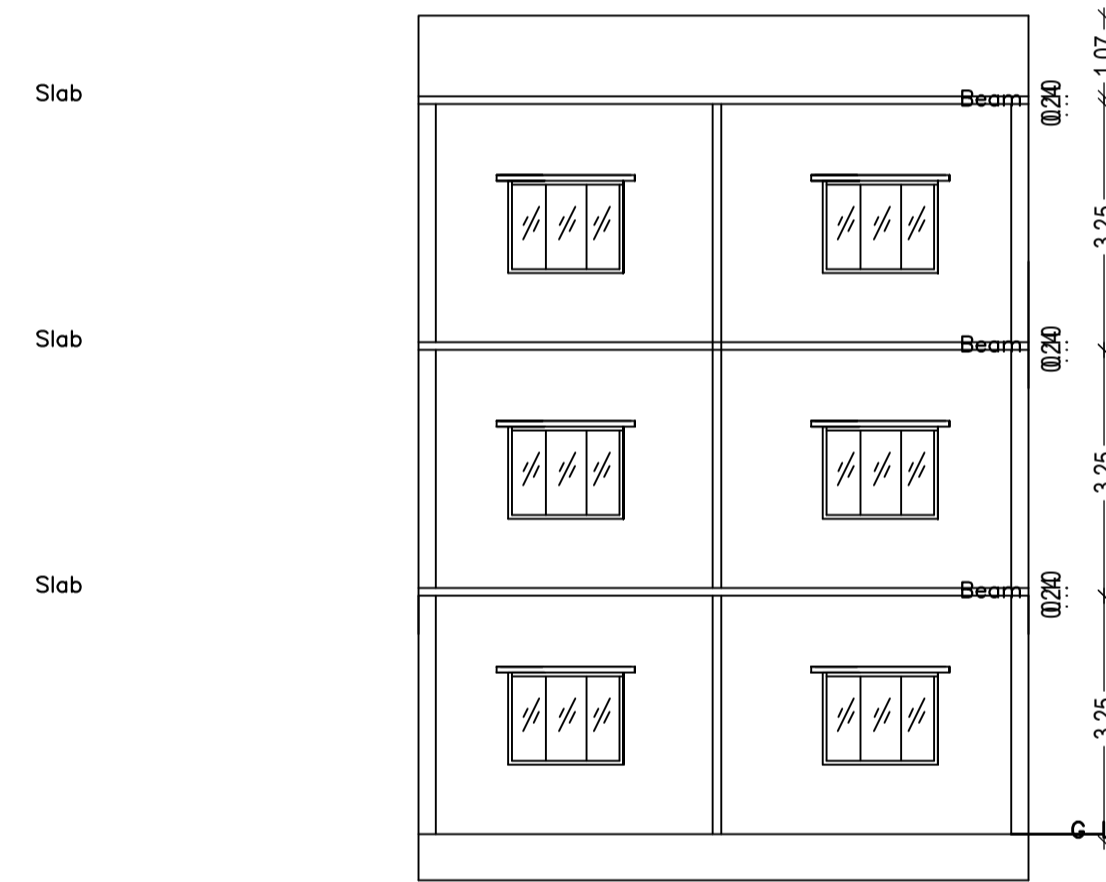
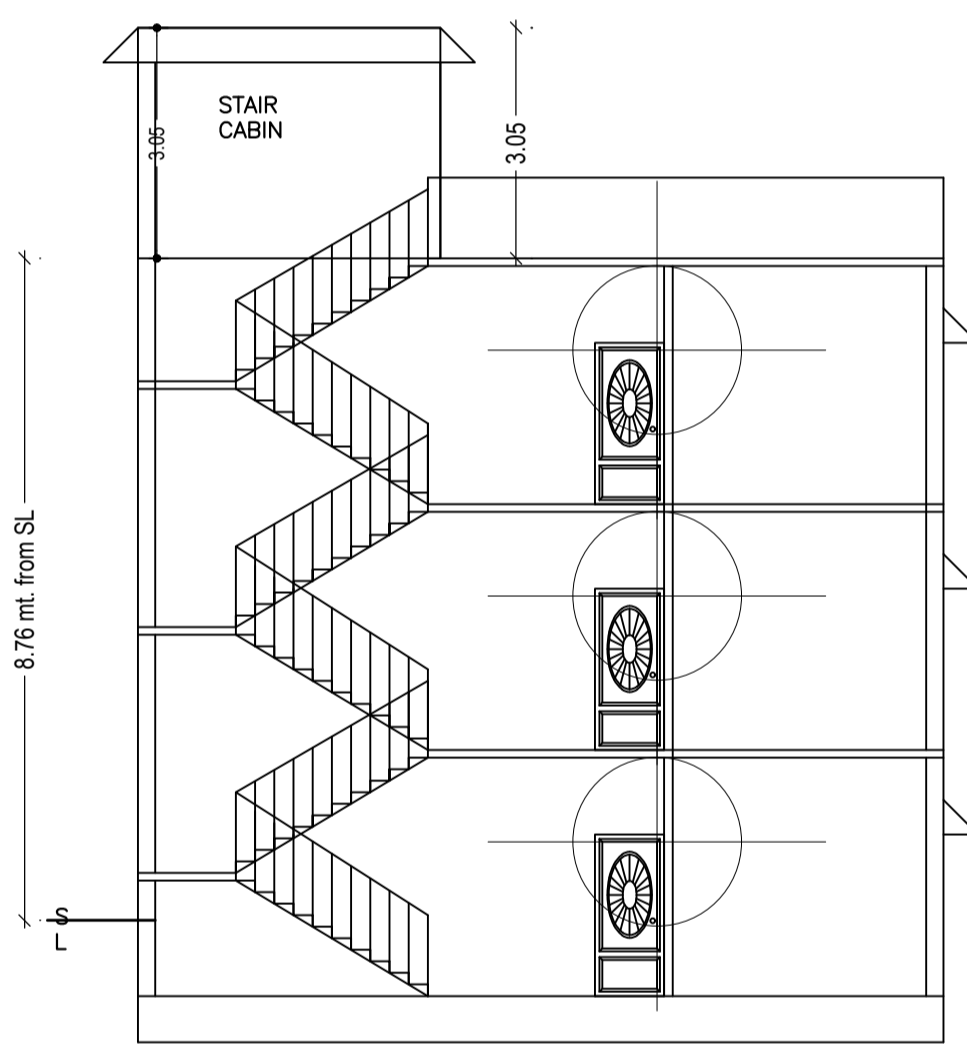
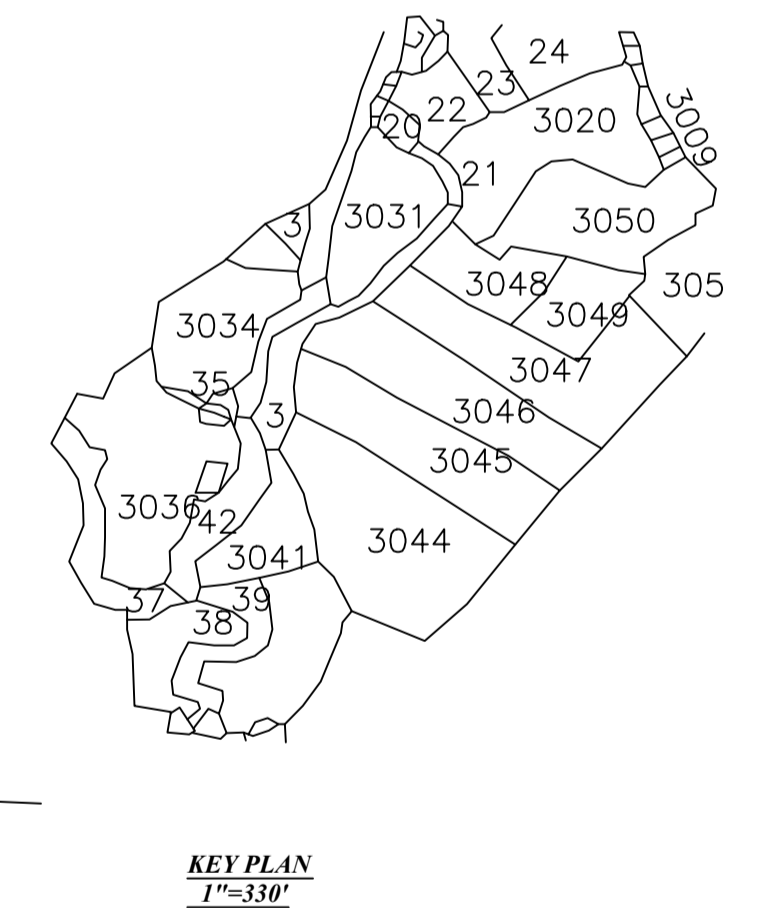
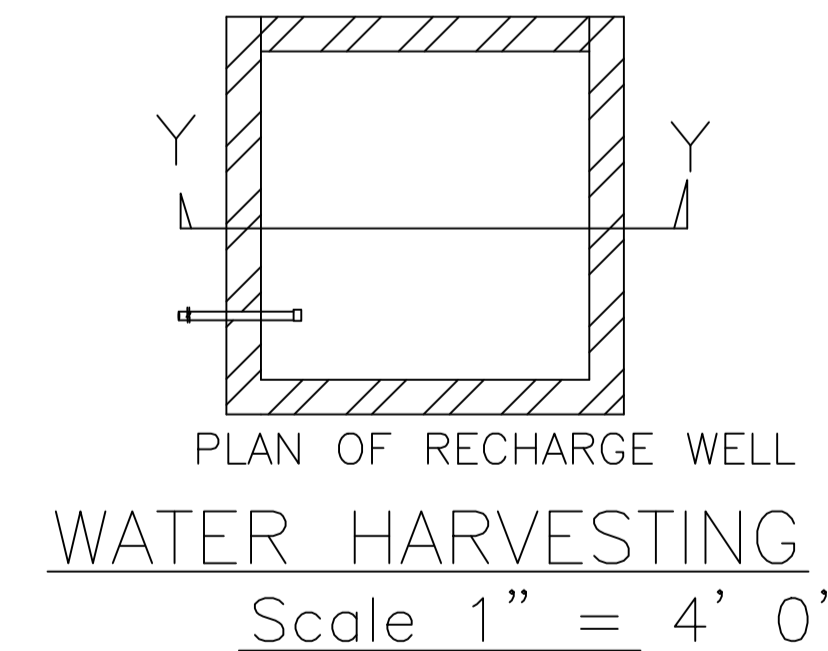
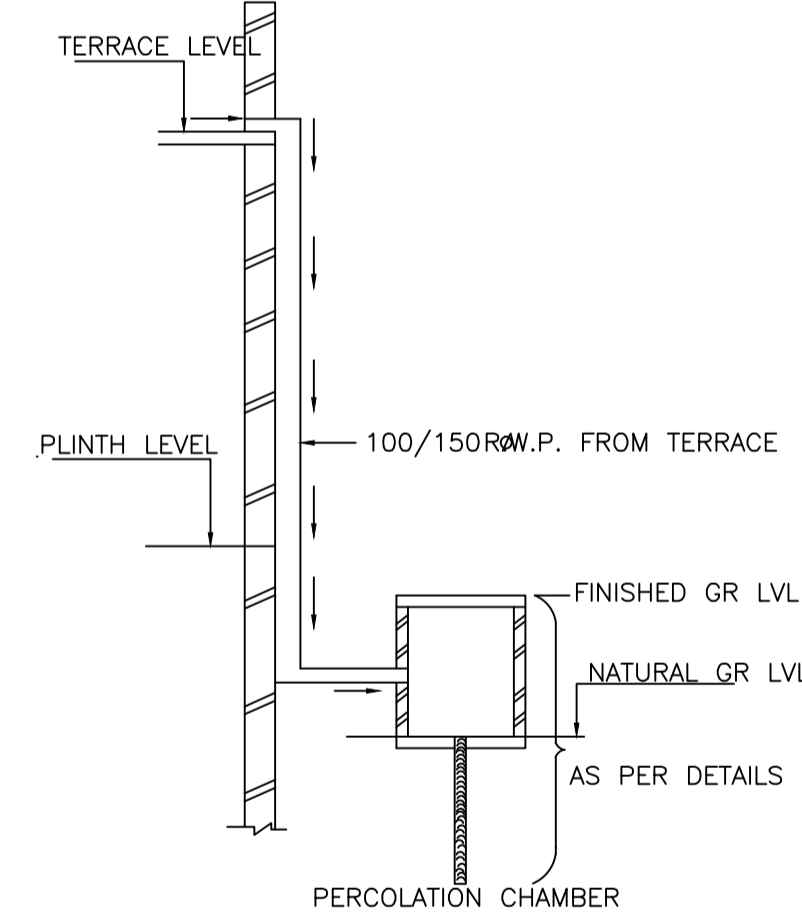
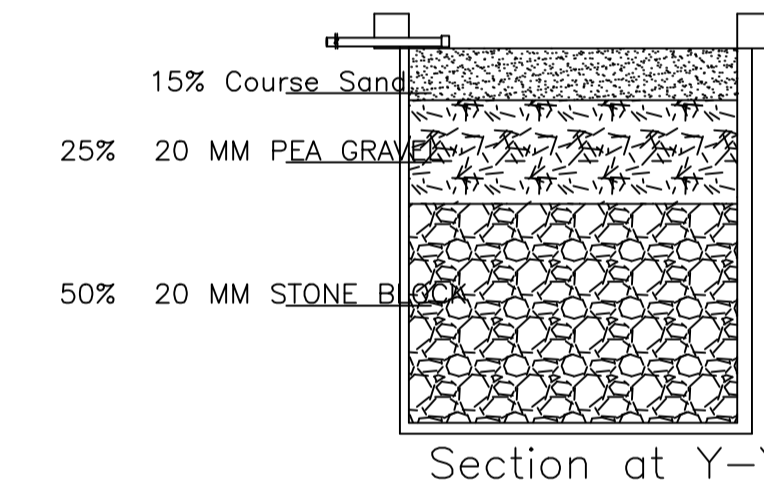
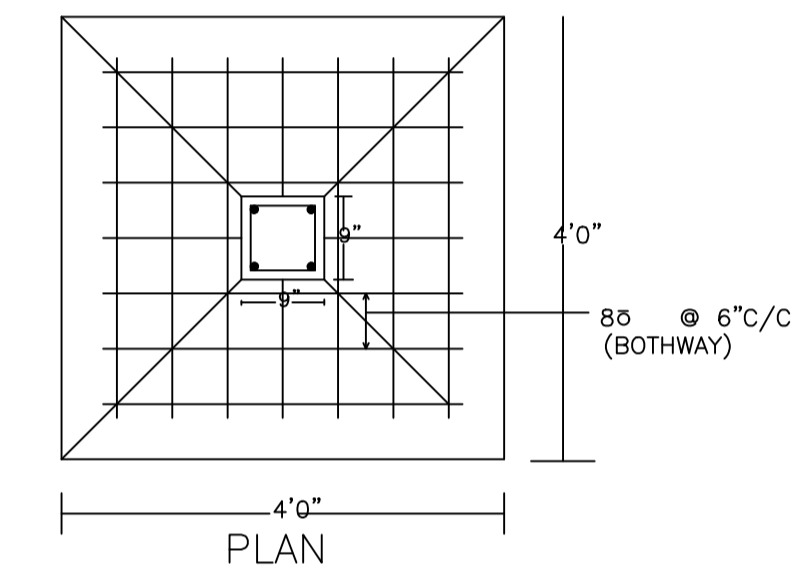
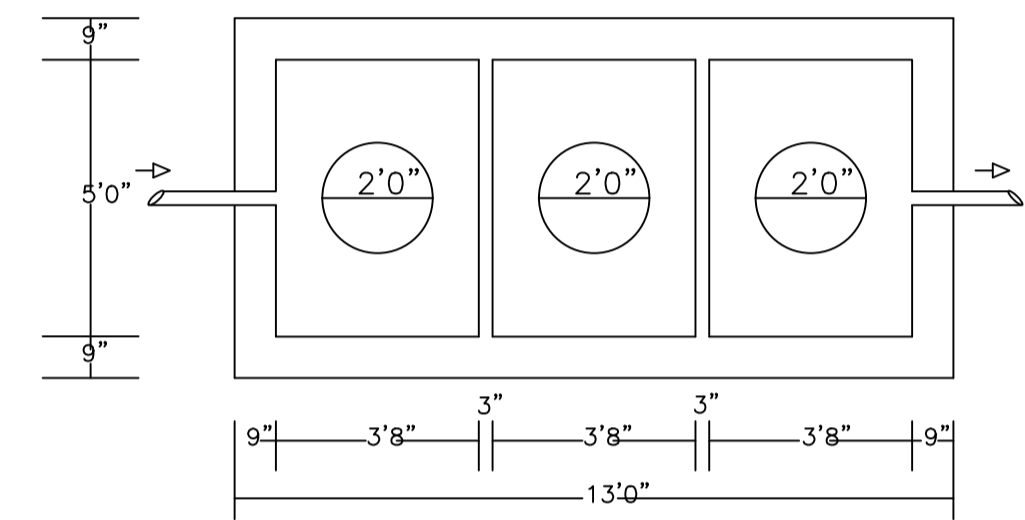

LTP NAME AND SIGNATURE	STRUCTURAL ENG'S NAME AND SIGNATURE	BUILDER NAME AND SIGNATURE	DIGITAL SIGNATURE
RAJEEV RANJAN SINGH DMC/ENG/0032/2017			