

Proposal Basic Information

Proposal File No.	DMC/BP/0300/W23/2023
Owner Name	BIJAYA DEVI
Khata No	56(new : 600)
Plot No	2163(new : 2944)
Village Name	Kolakusma
Use	Residential
SubUse	Bungalow/ Dwelling / Non Apartment

AREA STATEMENT	VERSION NO.: 1.0.66
DHANBAD MUNICIPAL CORPORATION	VERSION DATE: 16/10/2020
PROJECT DETAIL:	
Region: JHARKHAND URBAN LOCAL BODIES	Plot Use: Residential
District: DHANBAD	Plot SubUse: Bungalow/ Dwelling / Non Apartment
Authority: DHANBAD MUNICIPAL CORPORATION	PlotNearby/ReligiousStructure: NA
Inward No: DMC/BP/0300/W23/2023	Plot/SubPlot No: 2163(new : 2944)
Application Type: General Proposal	North: Plot No. - vikash kumar mandal
Project Type: Building Permission	South: Road Width - 3.66
Nature of Development: New	East: Plot No. - same plot
Location of Development Area: Old Area	West: Plot No. - jitendra pandey and others
AREA DETAILS:	
AREA OF PLOT (Minimum)	(A) 129.44 SQ.MT.
NET AREA OF PLOT(Gross Plot Area - Deduction from Gross Plot area)	(A-Deductions) 129.44
Deduction for Balance Plot Area(from Gross Plot Area)	
Common Plot	25.31
Total	25.31
BALANCE AREA OF PLOT(Net Plot Area - Recreational/Amenity space)	(A-Deductions) 104.13
PLOT AREA FOR COVERAGE(Net Plot Area)	(A-Deductions) 129.44
Plot Area for FAR (Net Plot Area + RoadWidening Area)	(A-Deductions) 129.44
COVERAGE CHECK	
Permissible Coverage area ( 70.00 % )	90.61
Proposed Coverage Area ( 62.15 % )	80.44
Total Prop. Coverage Area ( 62.15 % )	80.44
Balance coverage area ( 7.86 % )	10.17
FAR CHECK	
Perm. FAR Area ( 1.500 )	194.16
Total Perm. FAR area	194.16
Residential FAR	160.88
Proposed FAR Area	160.88
Total Proposed FAR Area	160.88
Consumed FAR (Factor)	1.24
Balance FAR Area	33.28
BUILT UP AREA CHECK	
Total Proposed BuiltUp Area	160.88
ARCHITECT (Regd)	AJAY KUMAR KESARI
ENGINEER (Regd)	
SUPERVISOR (Regd)	
OWNER (Regd)	BIJAYA DEVI
DEVELOPMENT AUTHORITY LOCAL BODY	

COLOR INDEX	
PLOT BOUNDARY	Black
ABUTTING ROAD	Green
PROPOSED CONSTRUCTION	Red
COMMON PLOT	Yellow
ROAD WIDENING AREA	Blue
EXISTING (To be retained)	Light Blue
EXISTING (To be demolished)	Dark Blue

Floor Name	Building Name		Total	
	Proposed Built Up Area (Sq.mt.)	Proposed FAR Area (Sq.mt.)	Total Proposed Built Up Area (Sq.mt.)	Total FAR Area (Sq.mt.)
Ground Floor	80.44	80.44	80.44	80.44
First Floor	80.44	80.44	80.44	80.44
Terrace Floor	0.00	0.00	0.00	0.00
<b>Total :</b>	<b>160.88</b>	<b>160.88</b>	<b>160.88</b>	<b>160.88</b>

Building Name	Building Use	Building SubUse	Building Structure
A (A)	Residential	Bungalow/ Dwelling / Non Apartment	Non-Highrise

SCHEDULE OF DOOR:				
BUILDING NAME	NAME	LENGTH	HEIGHT	NOS
A (A)	d	0.90	2.10	12

SCHEDULE OF WINDOW/VENTILATION:				
BUILDING NAME	NAME	LENGTH	HEIGHT	NOS
A (A)	w	1.13	1.20	02
A (A)	w	1.45	1.20	02
A (A)	w	1.80	1.20	14

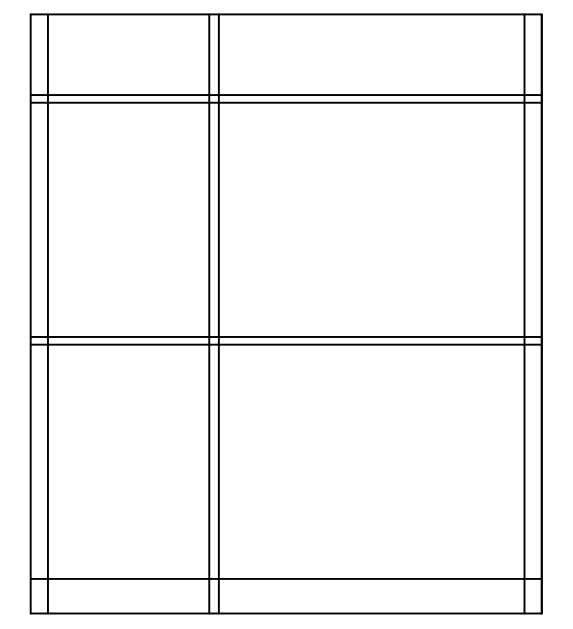
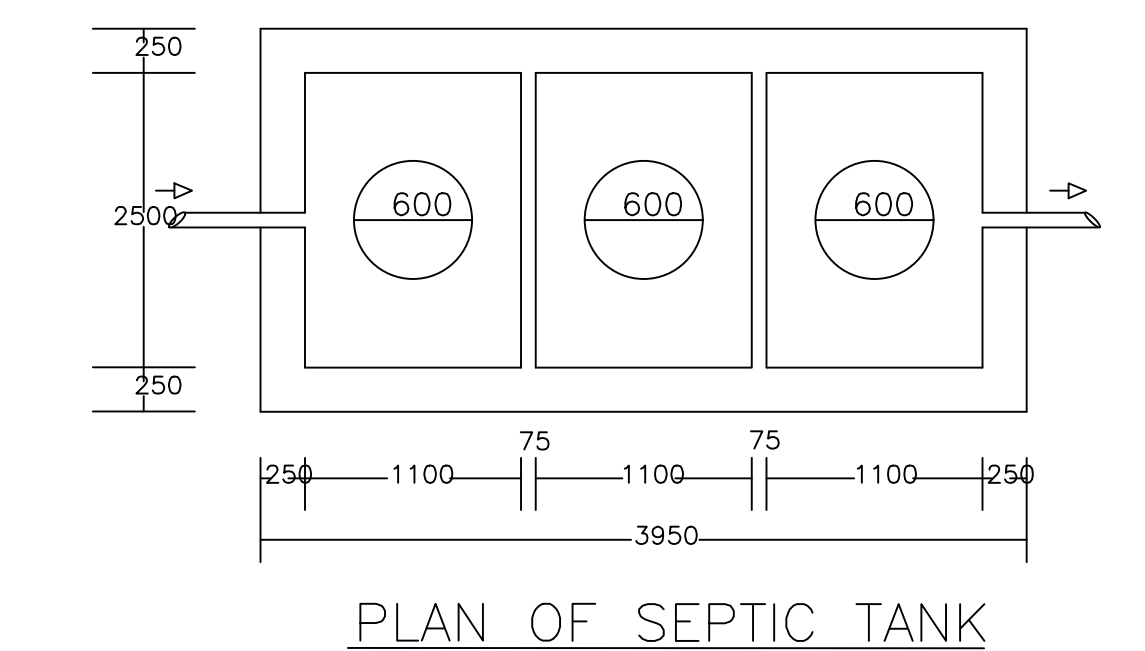
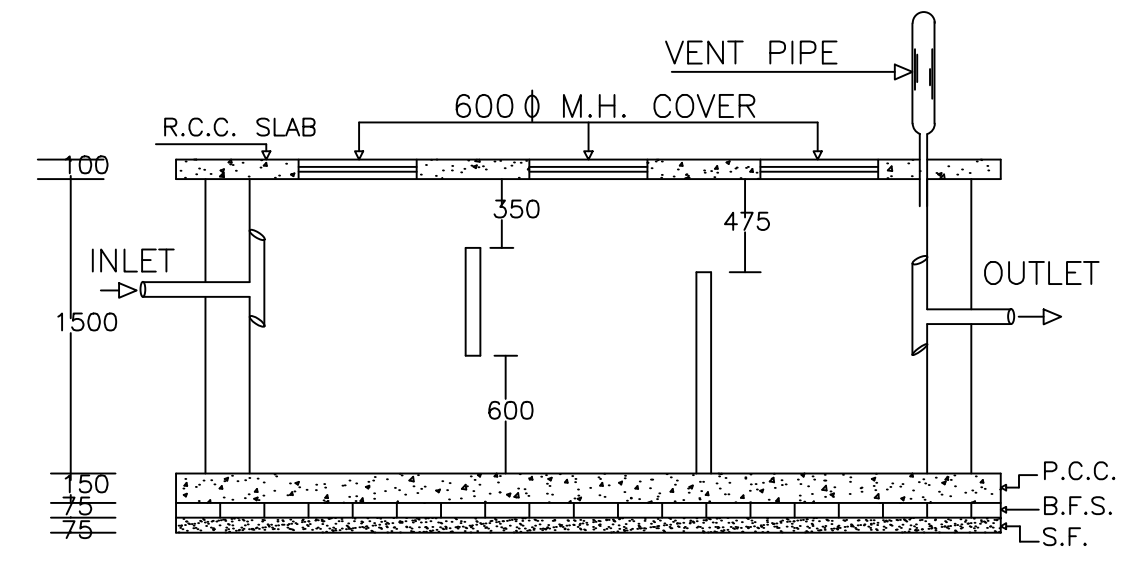
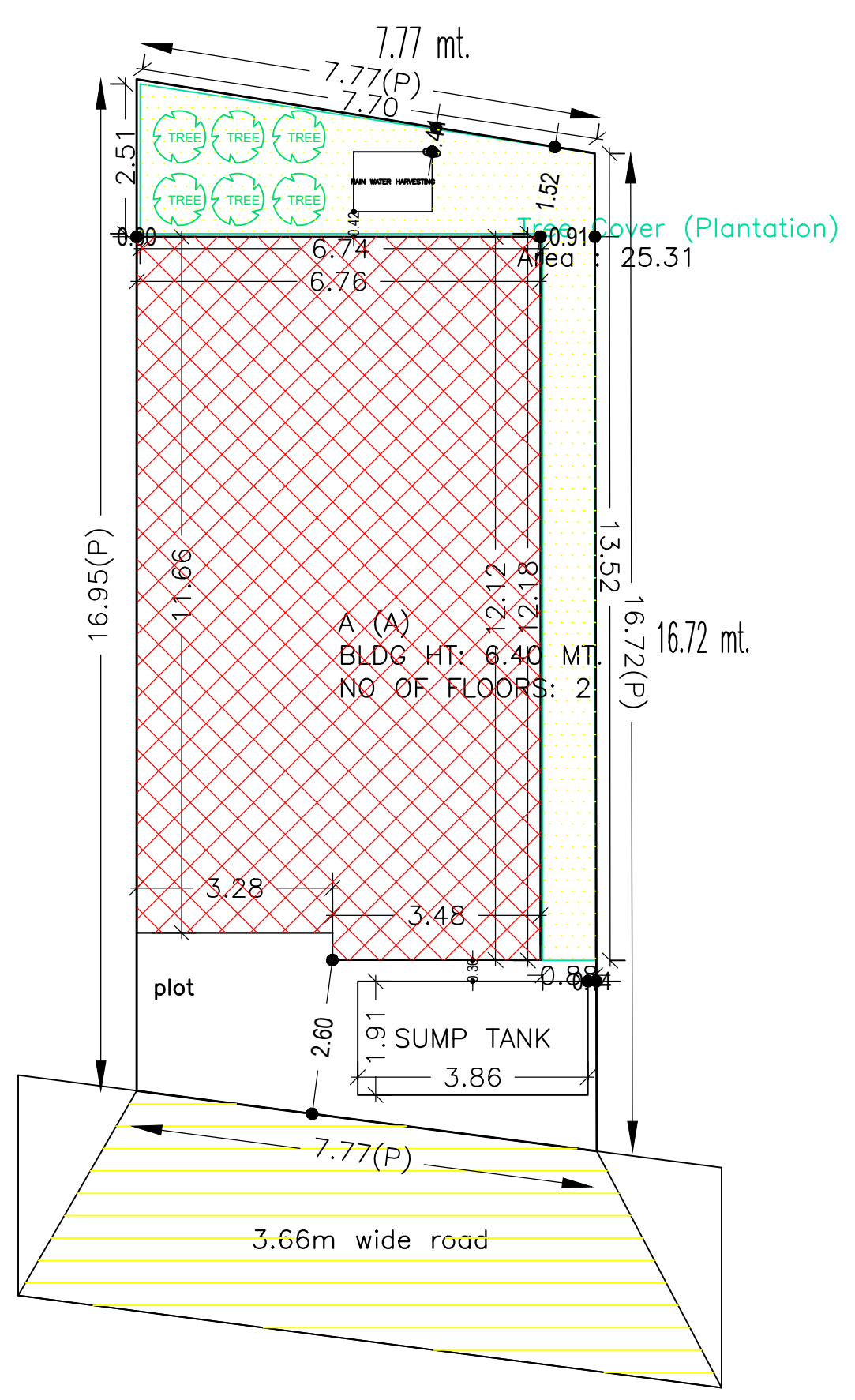

SECTION ON X-X

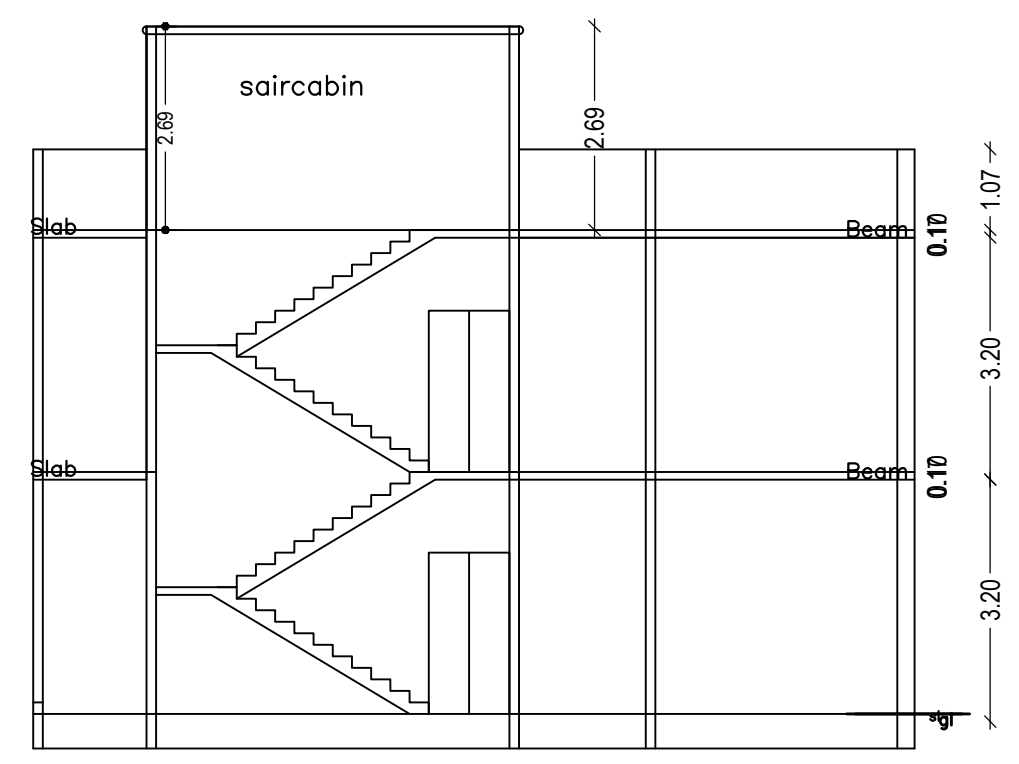

SECTION ON Y-Y

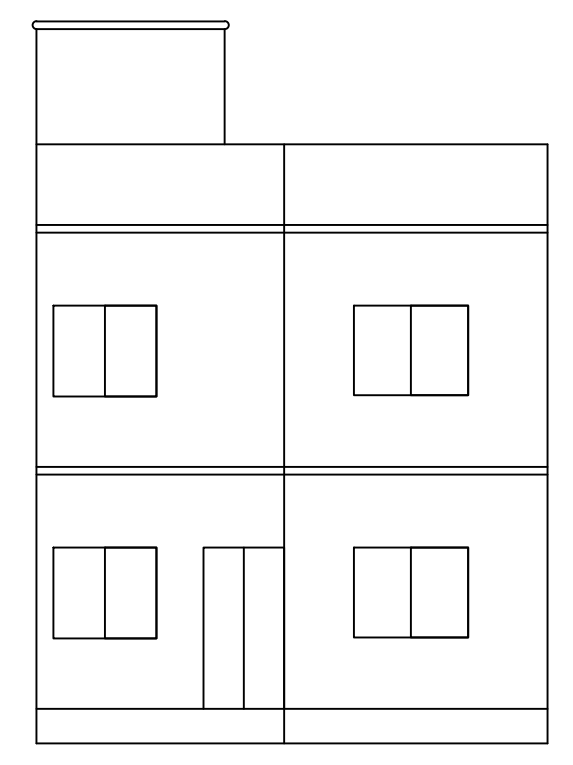

FRONT ELEVATION

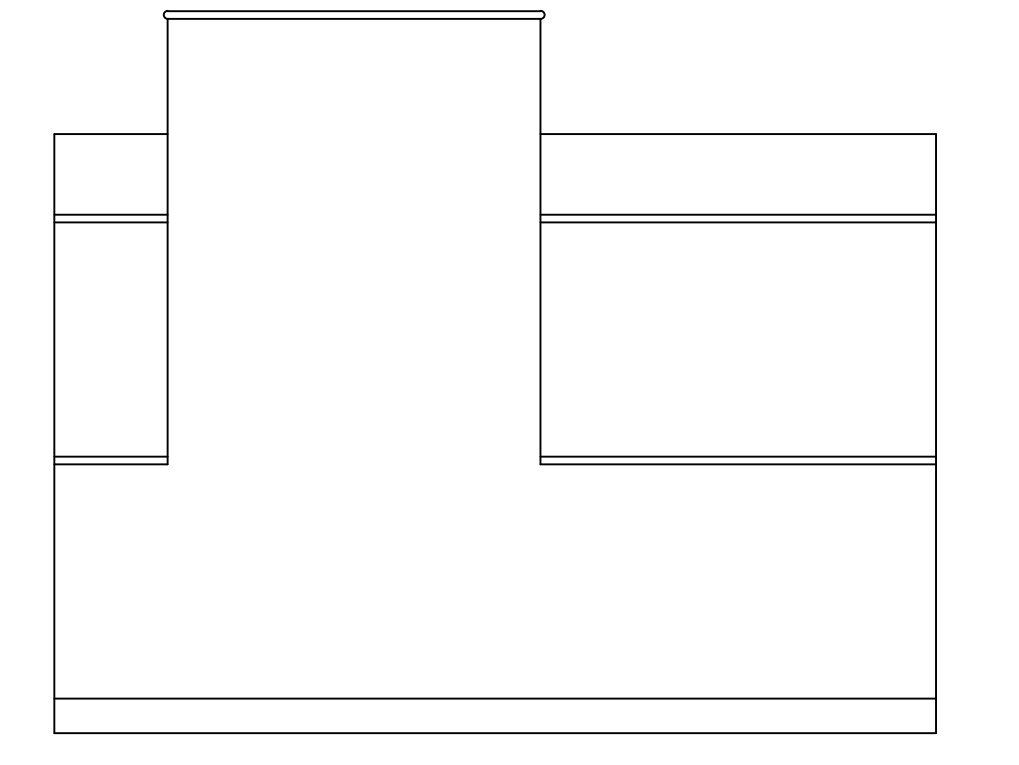

LEFT SIDE ELEVATION

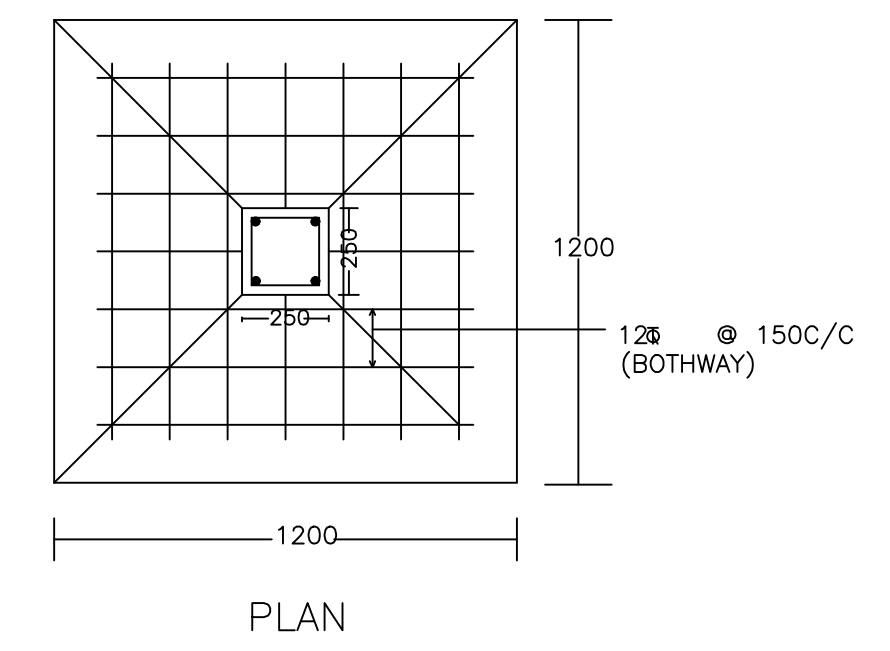
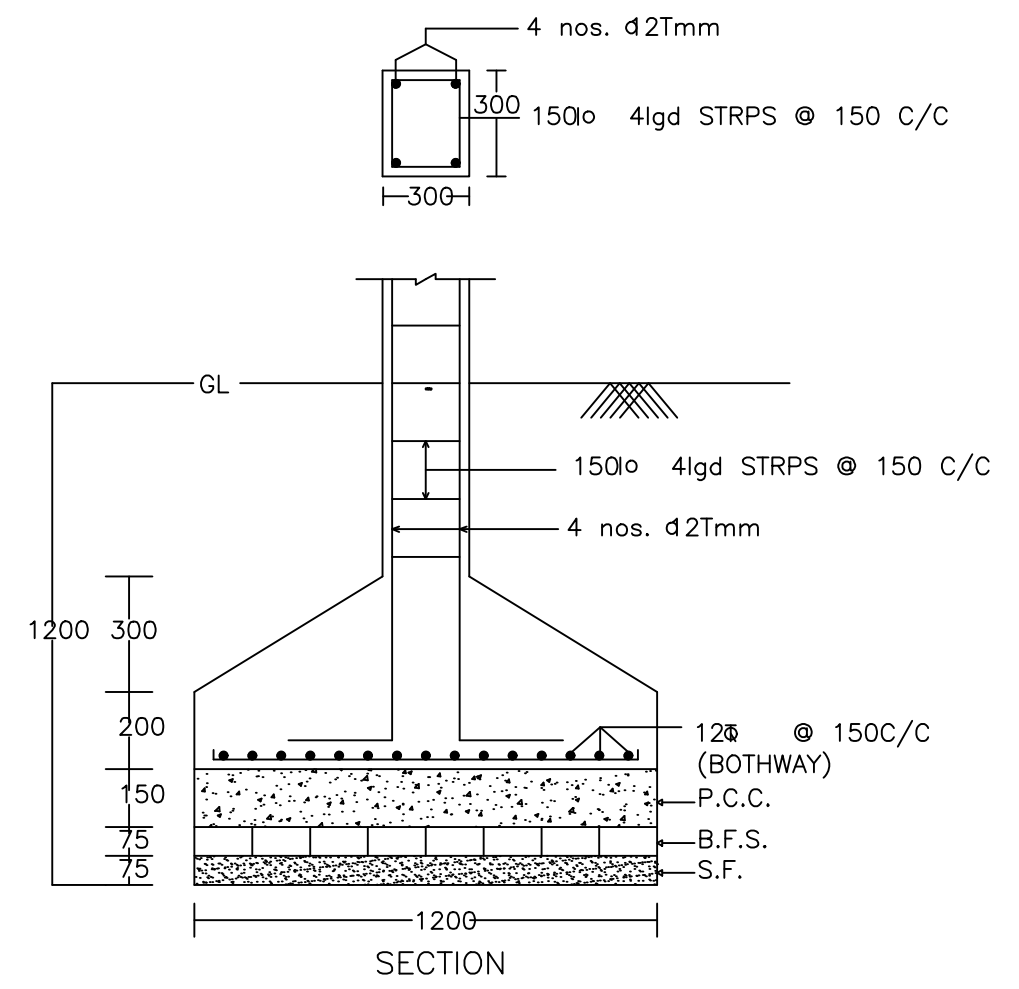
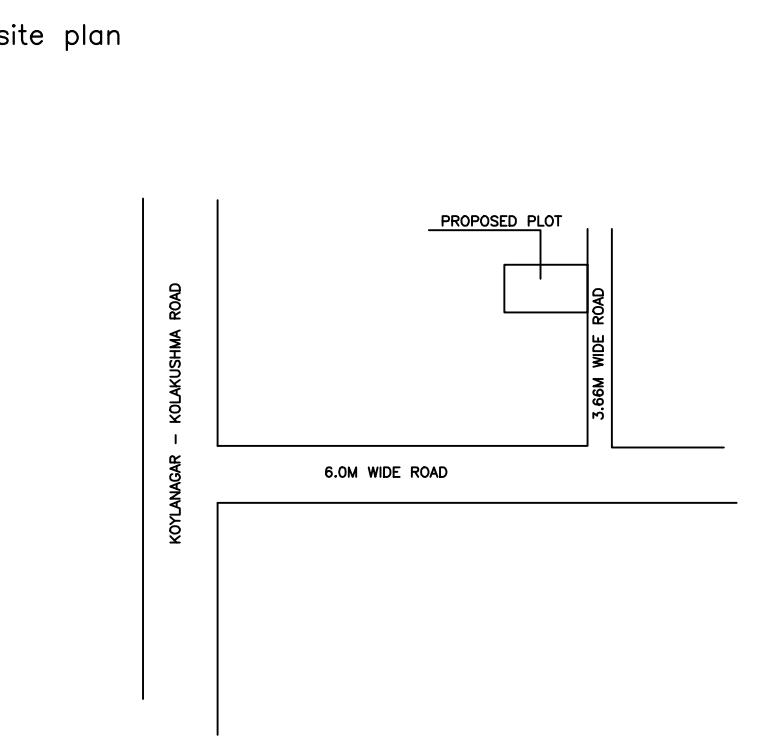

DETAIL OF COLUMNS

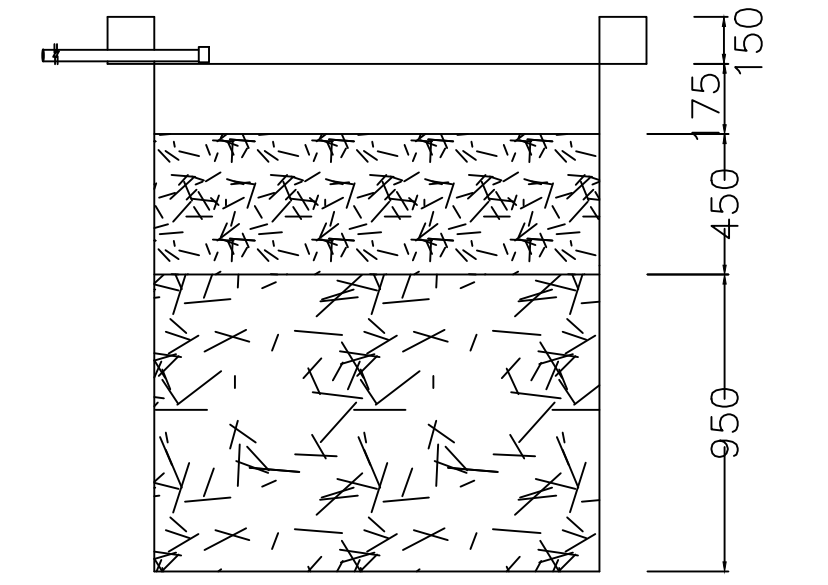

SECTION AT Y-Y

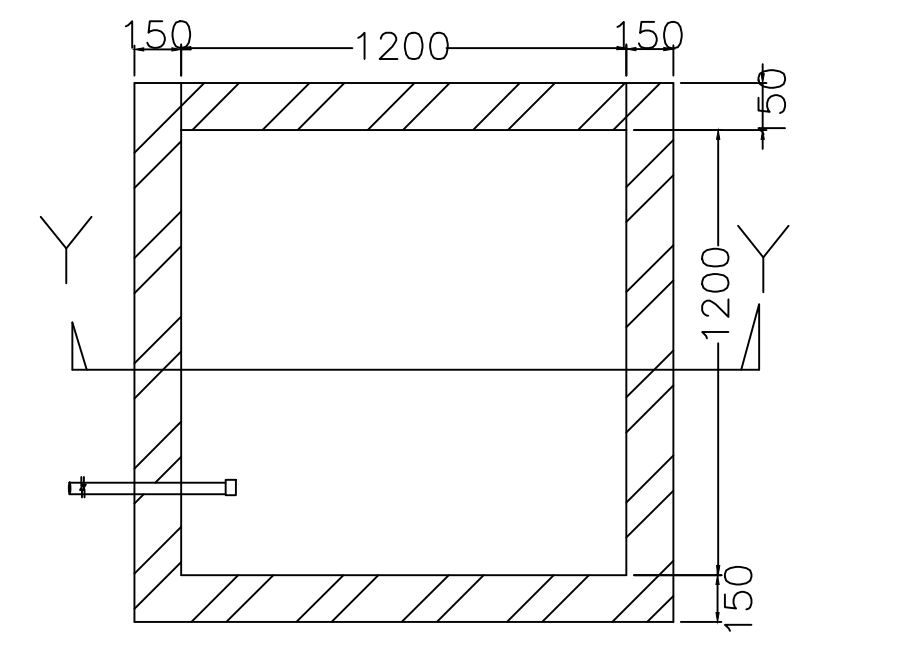

PLAN OF RECHARGE WELL

WATER HARVESTING

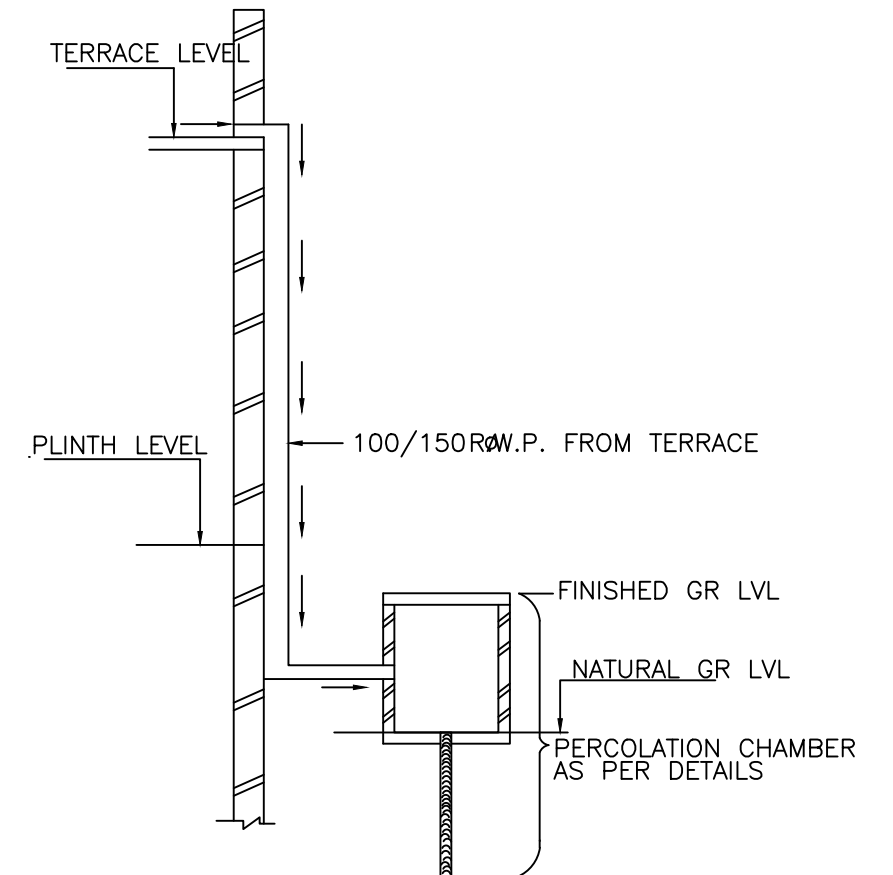

ROOF TOP RAIN WATER COLLECTION SYSTEM

Floor Name	Total Built Up Area (Sq.mt.)	Proposed FAR Area (Sq.mt.) Resi.	Total FAR Area (Sq.mt.)	Total Consumed Additional FAR Area (Sq.mt.)	Tnmt (No.)
Ground Floor	80.44	80.44	80.44	80.44	01
First Floor	80.44	80.44	80.44	80.44	00
Terrace Floor	0.00	0.00	0.00	0.00	00
<b>Total :</b>	<b>160.88</b>	<b>160.88</b>	<b>160.88</b>	<b>160.88</b>	<b>01</b>
Total Number of Same Buildings	1				
<b>Total :</b>	<b>160.88</b>	<b>160.88</b>	<b>160.88</b>	<b>160.88</b>	<b>01</b>

FLOOR	Name	UnitBUA Type	UnitBUA Area	Carpet Area	No. of Rooms	No. of Tenement
GROUND FLOOR PLAN	SPLIT 1	FLAT	160.88	160.80	7	1
FIRST FLOOR PLAN	SPLIT 1	FLAT	0.00	0.00	7	0
<b>Total:</b>	-	-	160.88	160.80	14	1

FAR & Tenement Details (Table 4c-1)						
Building	No. of Same Bldg	Total Built Up Area (Sq.mt.)	Proposed FAR Area (Sq.mt.) Resi.	Total FAR Area (Sq.mt.)	Total Consumed Additional FAR Area (Sq.mt.)	Tnmt (No.)
A (A)	1	160.88	160.88	160.88	160.88	01
<b>Grand Total :</b>	<b>1</b>	<b>160.88</b>	<b>160.88</b>	<b>160.88</b>	<b>160.88</b>	<b>01</b>

LTP NAME AND SIGNATURE	STRUCTURAL ENG'S NAME AND SIGNATURE	BUILDER NAME AND SIGNATURE	DIGITAL SIGNATURE
AJAY KUMAR KESARI DMC/ENG/0007/2021			

Proposal Basic Information

Proposal File No.	DMC/BP/0300/W23/2023
Owner Name	BIJAYA DEVI
Khata No	56(new : 600)
Plot No	2163(new : 2944)
Village Name	Kolakusma
Use	Residential
SubUse	Bungalow/ Dwelling / Non Apartment

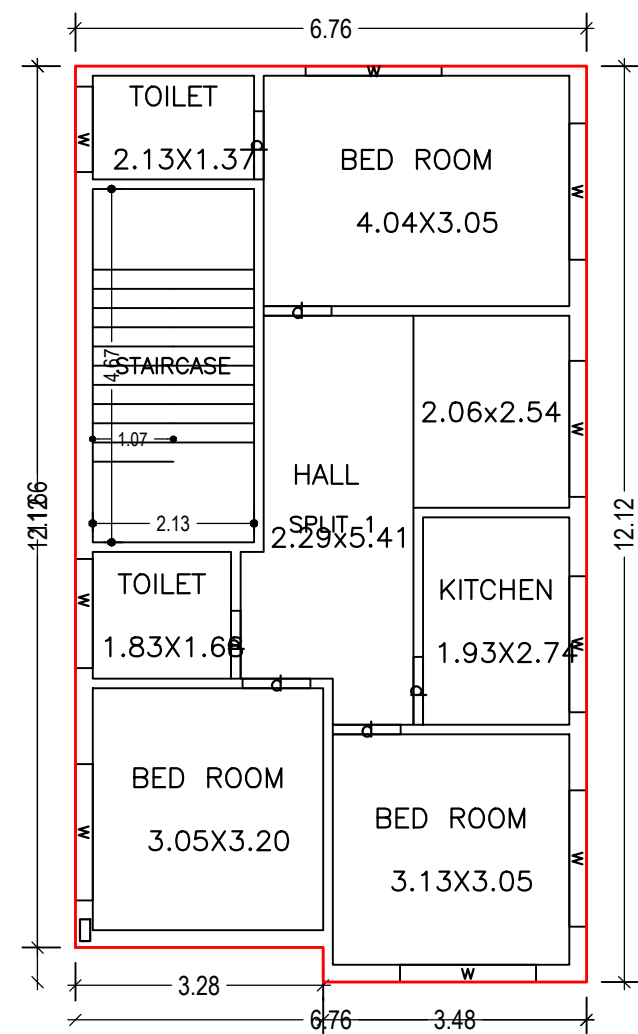

GROUND FLOOR PLAN  
(Proposed)  
(SCALE 1:100)

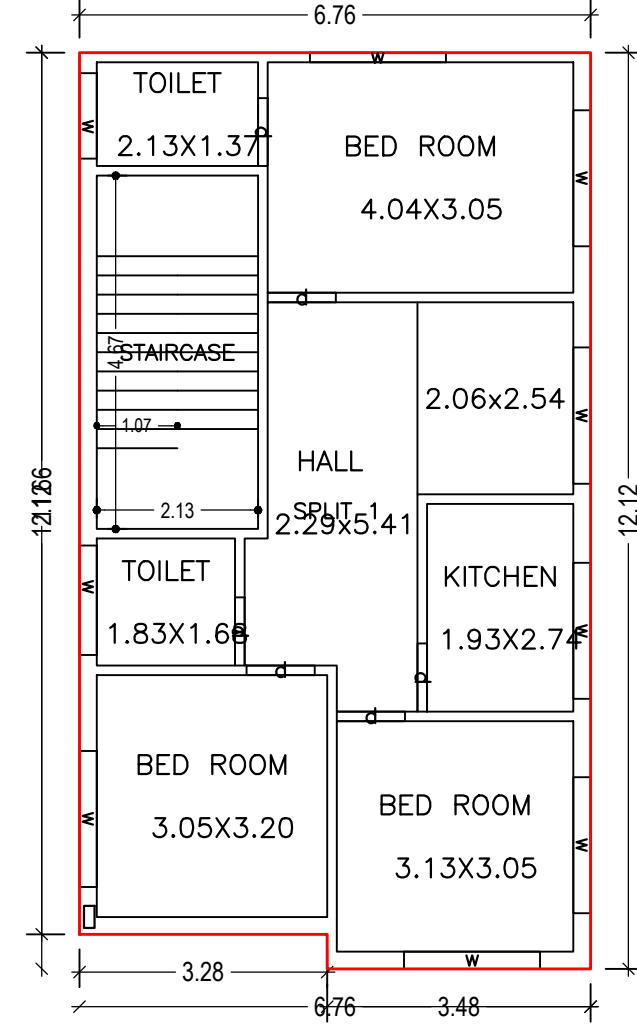

FIRST FLOOR PLAN  
(Proposed)  
(SCALE 1:100)

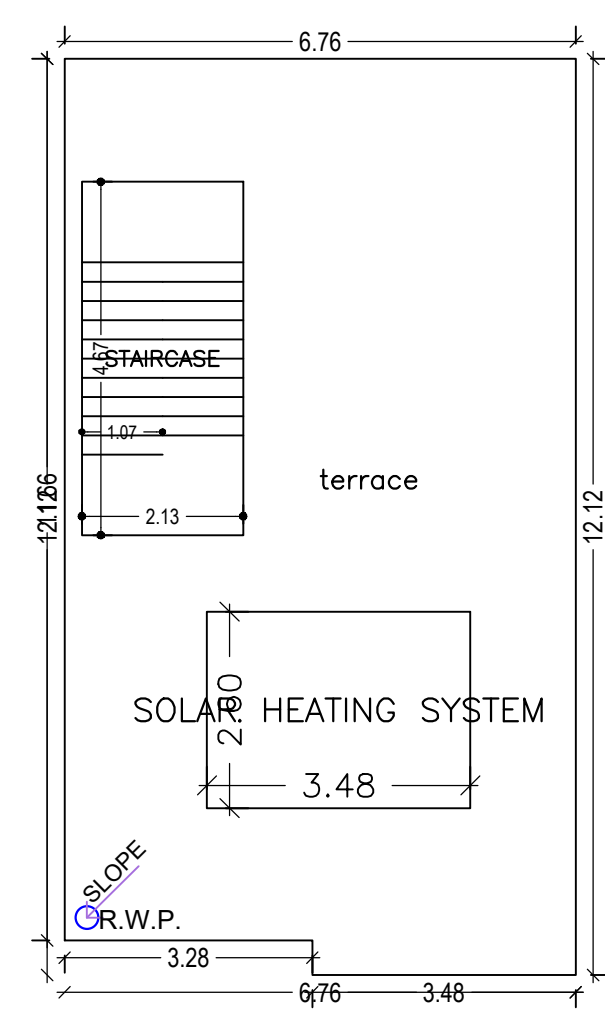

TERRACE FLOOR PLAN  
(SCALE 1:100)

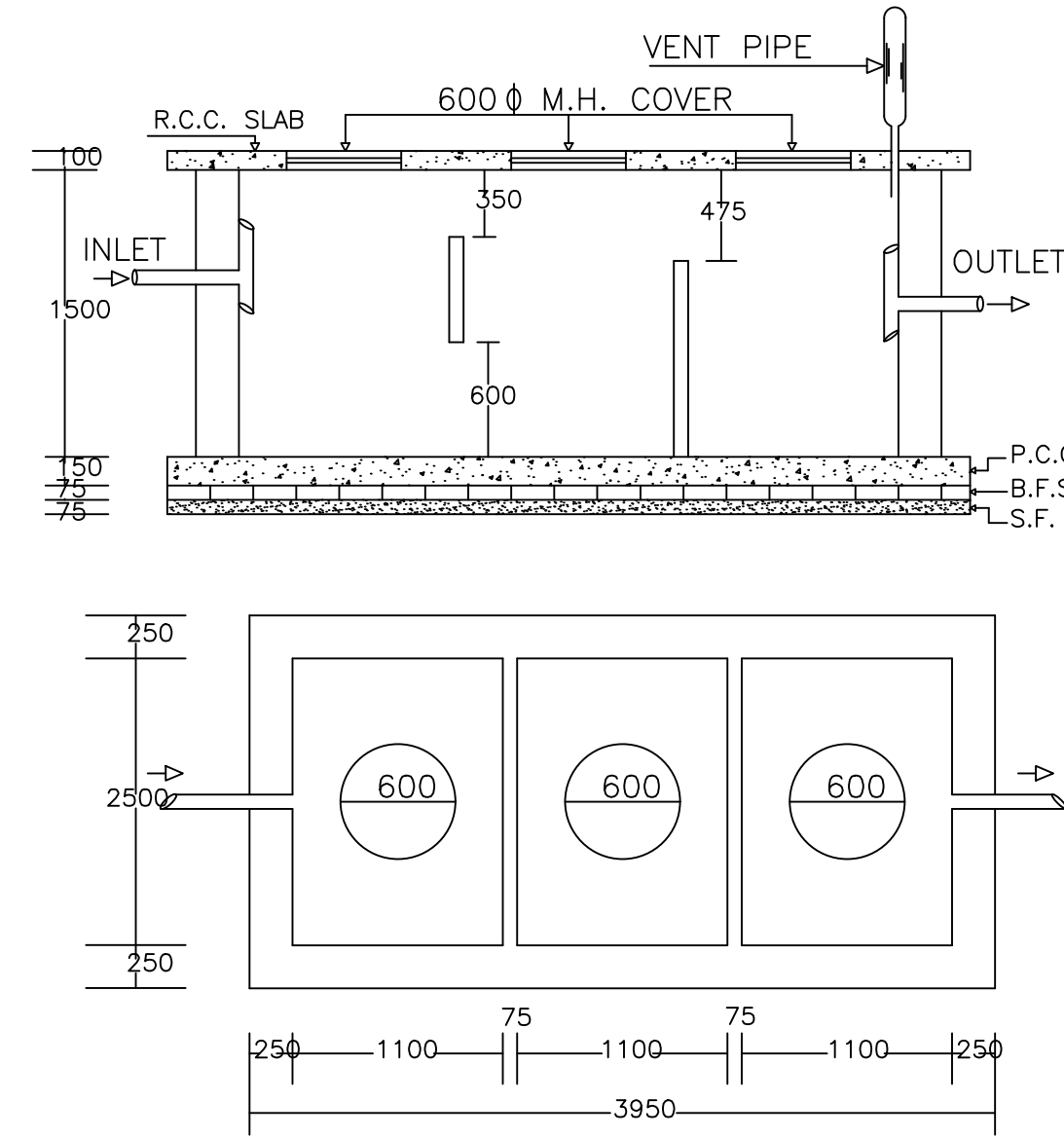

PLAN OF SEPTIC TANK

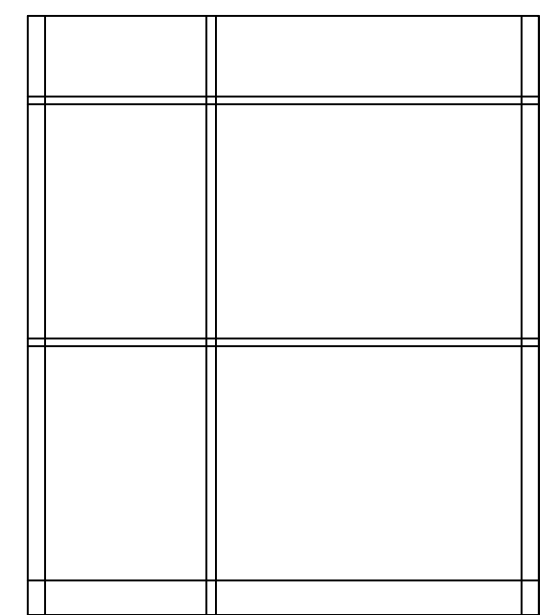
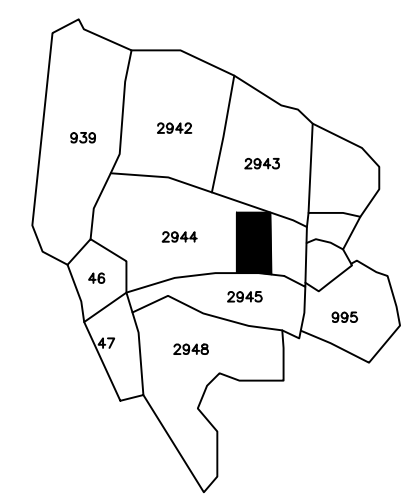
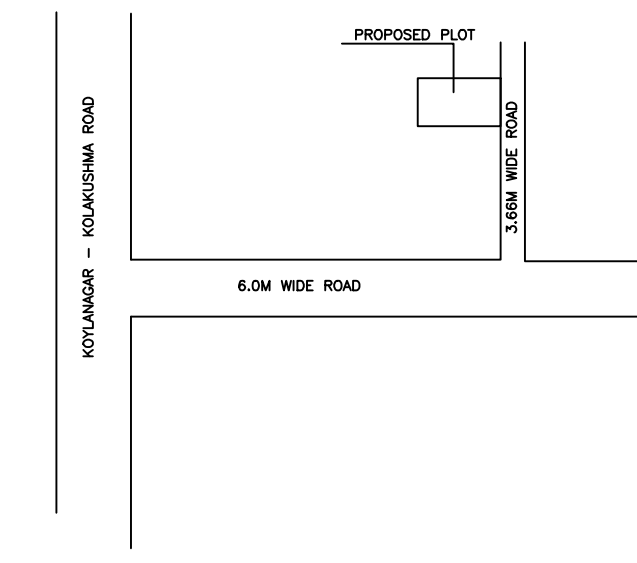

SECTION ON X-X

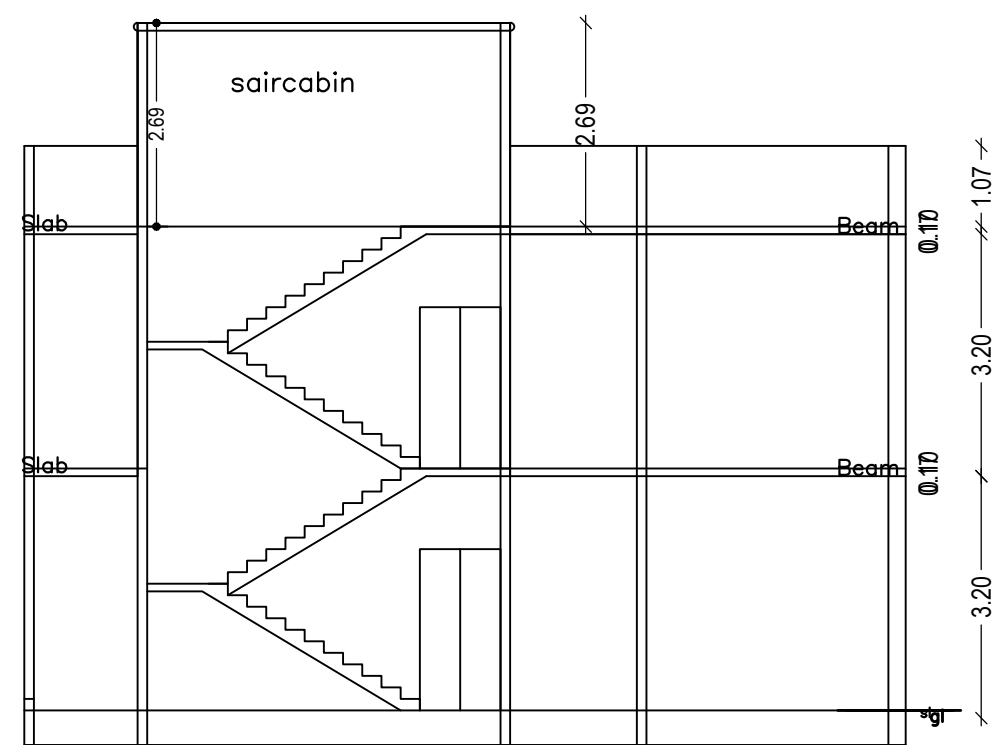

SECTION ON Y-Y

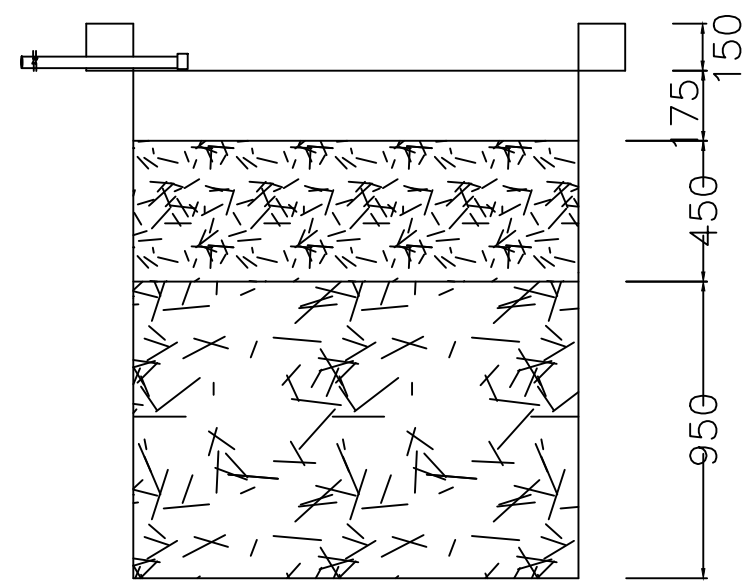

SECTION AT Y-Y

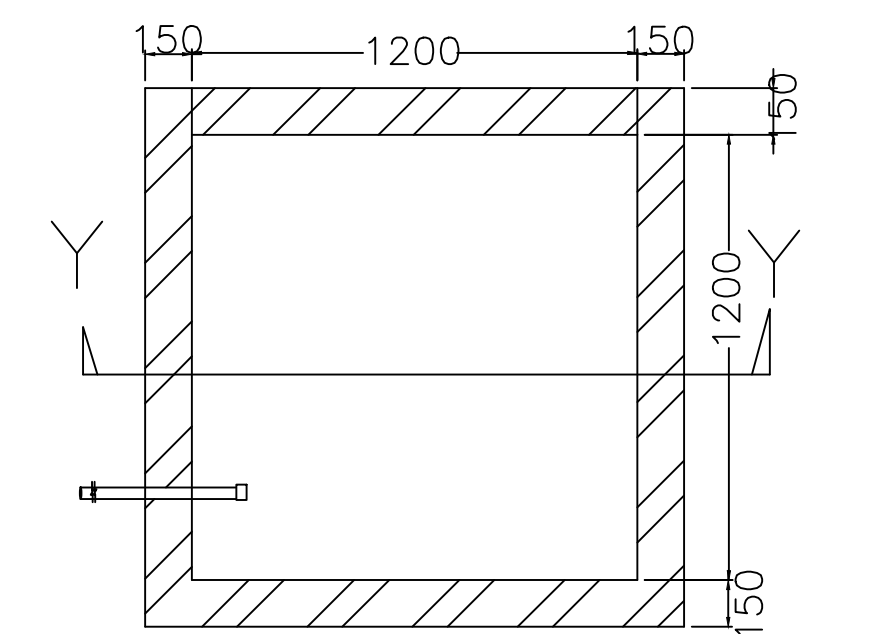

PLAN OF RECHARGE WELL

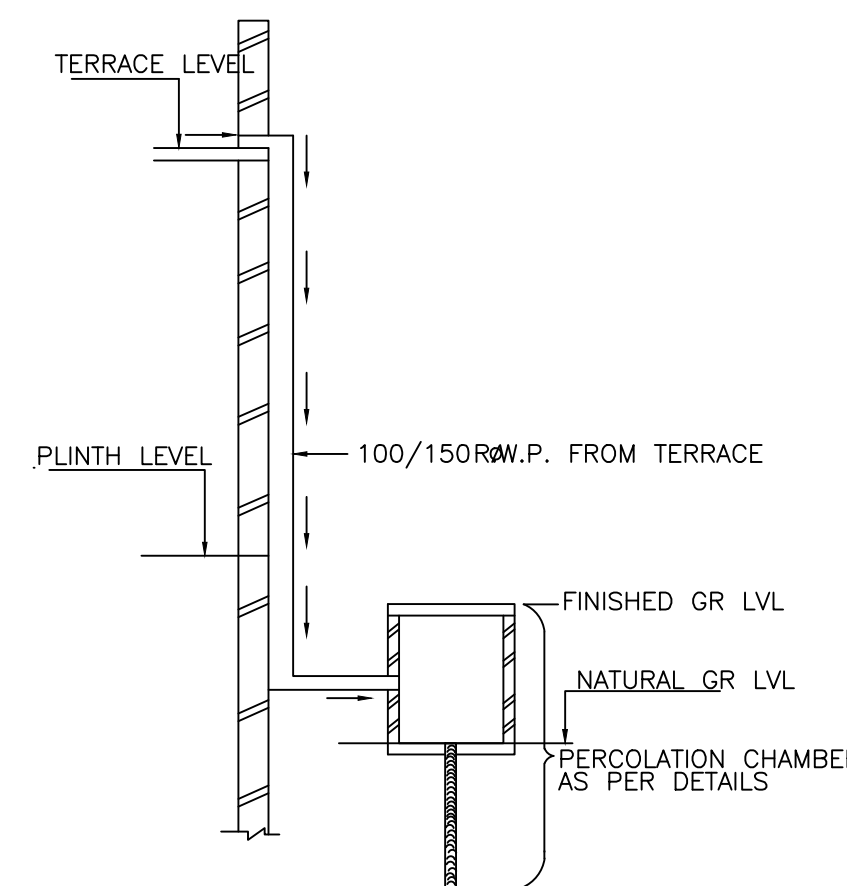

ROOF TOP RAIN WATER  
COLLECTION SYSTEM

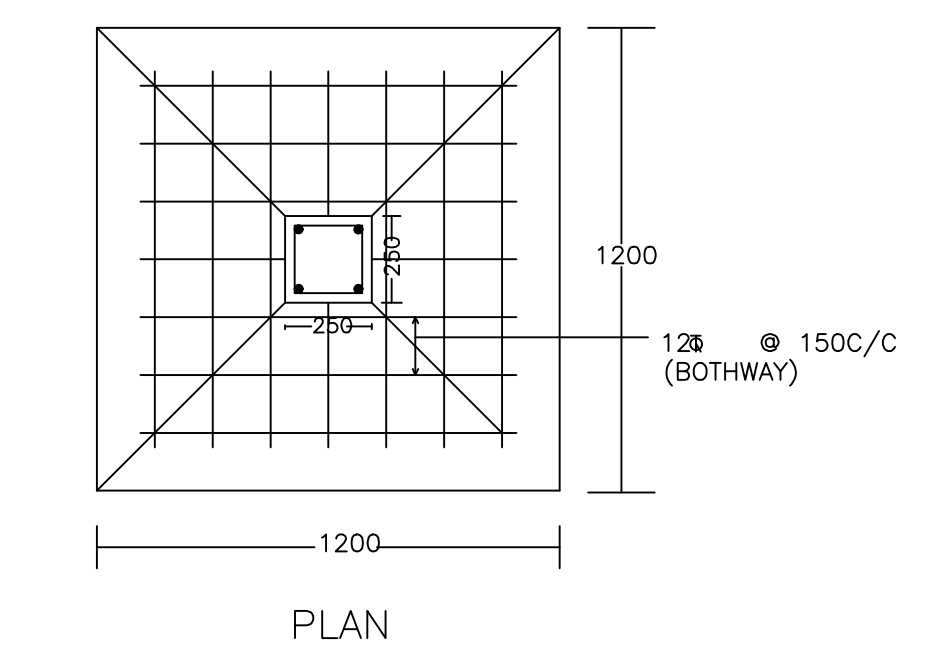
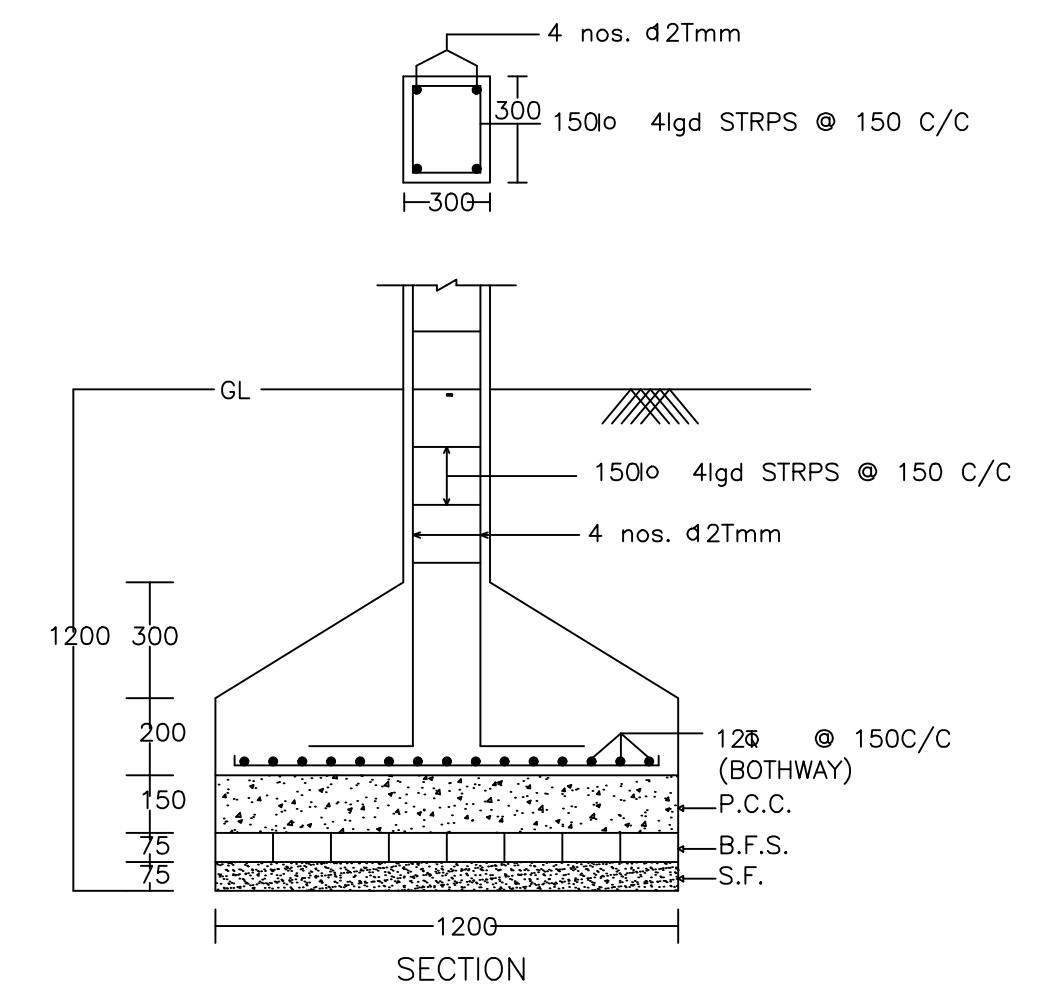

DETAIL OF COLUMNS

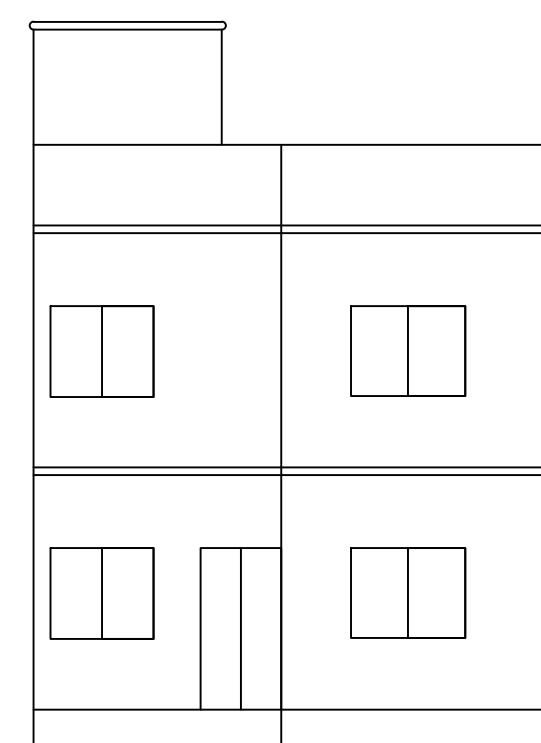

FRONT ELEVATION

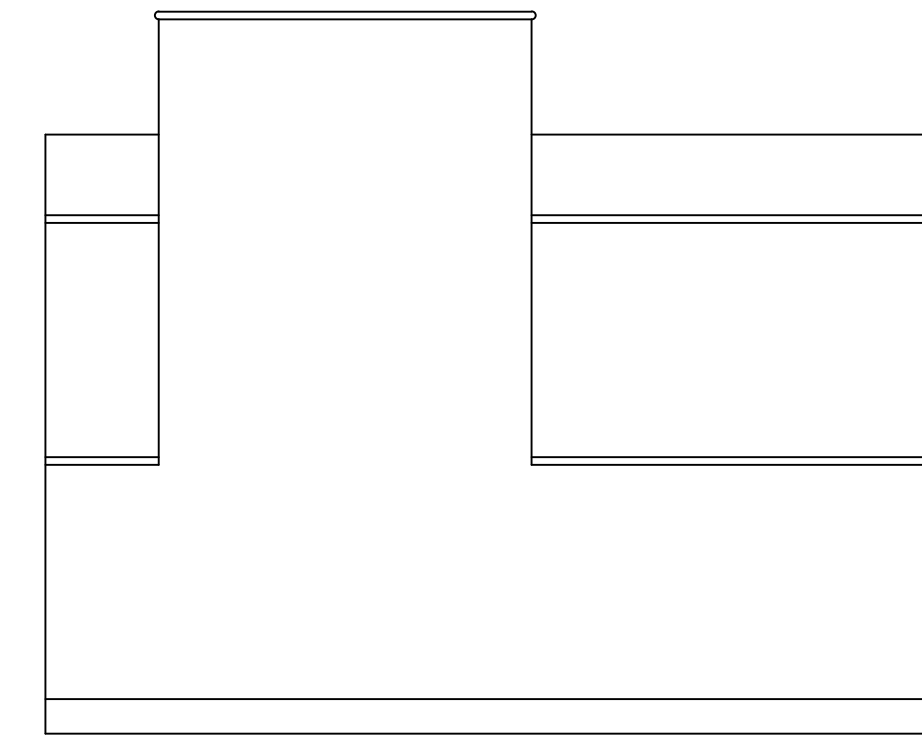

LEFT SIDE ELEVATION

LTP NAME AND SIGNATURE	STRUCTURAL ENG'S NAME AND SIGNATURE	BUILDER NAME AND SIGNATURE	DIGITAL SIGNATURE
AJAY KUMAR KESARI DMC/ENG/0007/2021			