

Project Title: MD ASLAM MANSURI

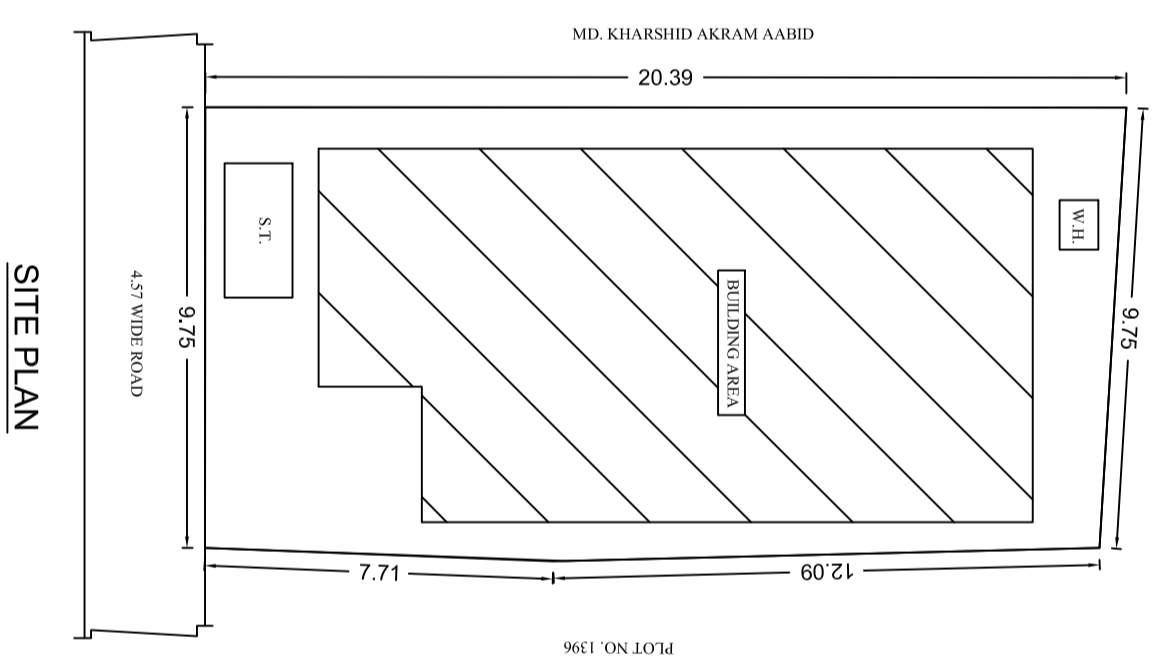
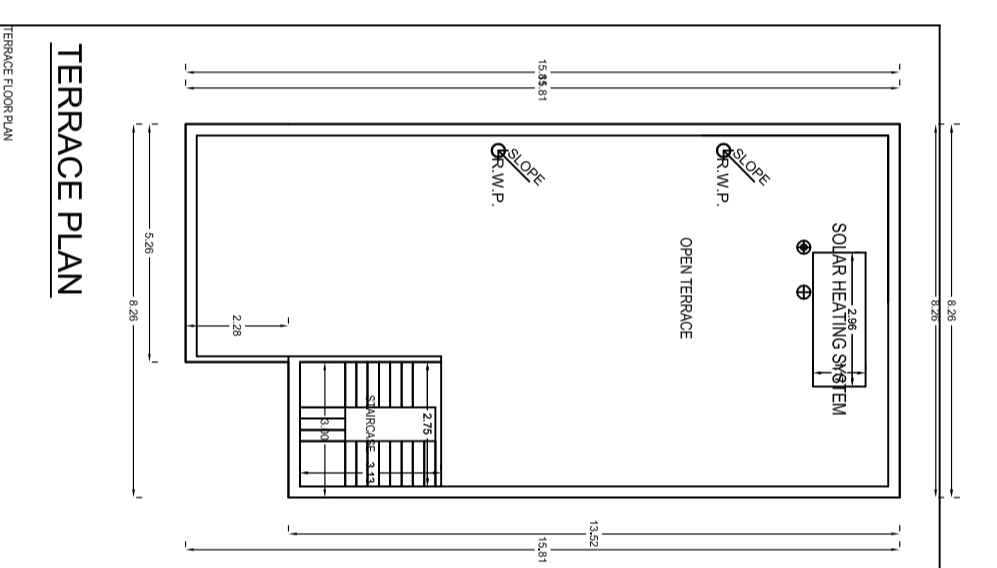
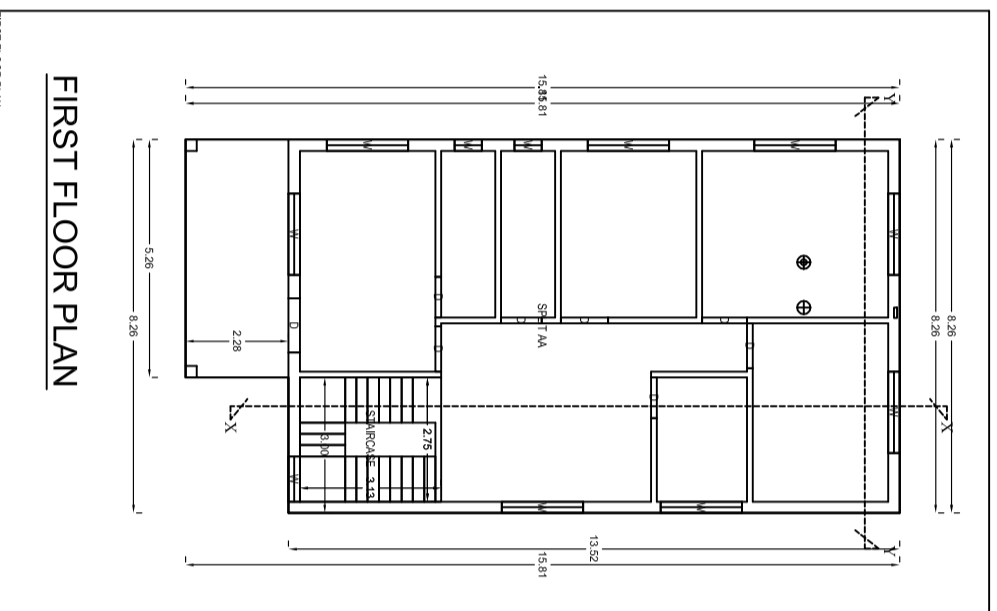
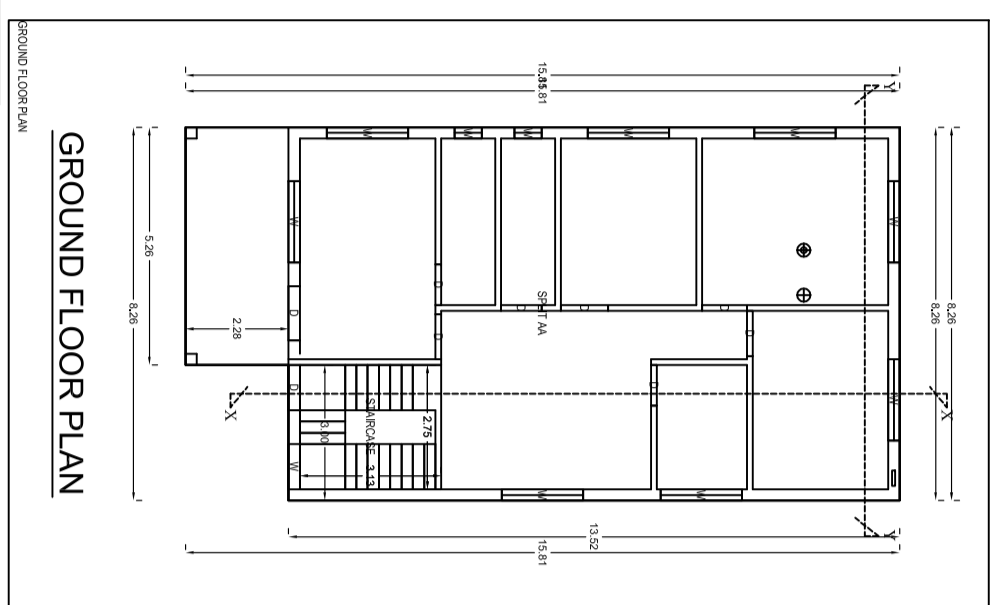
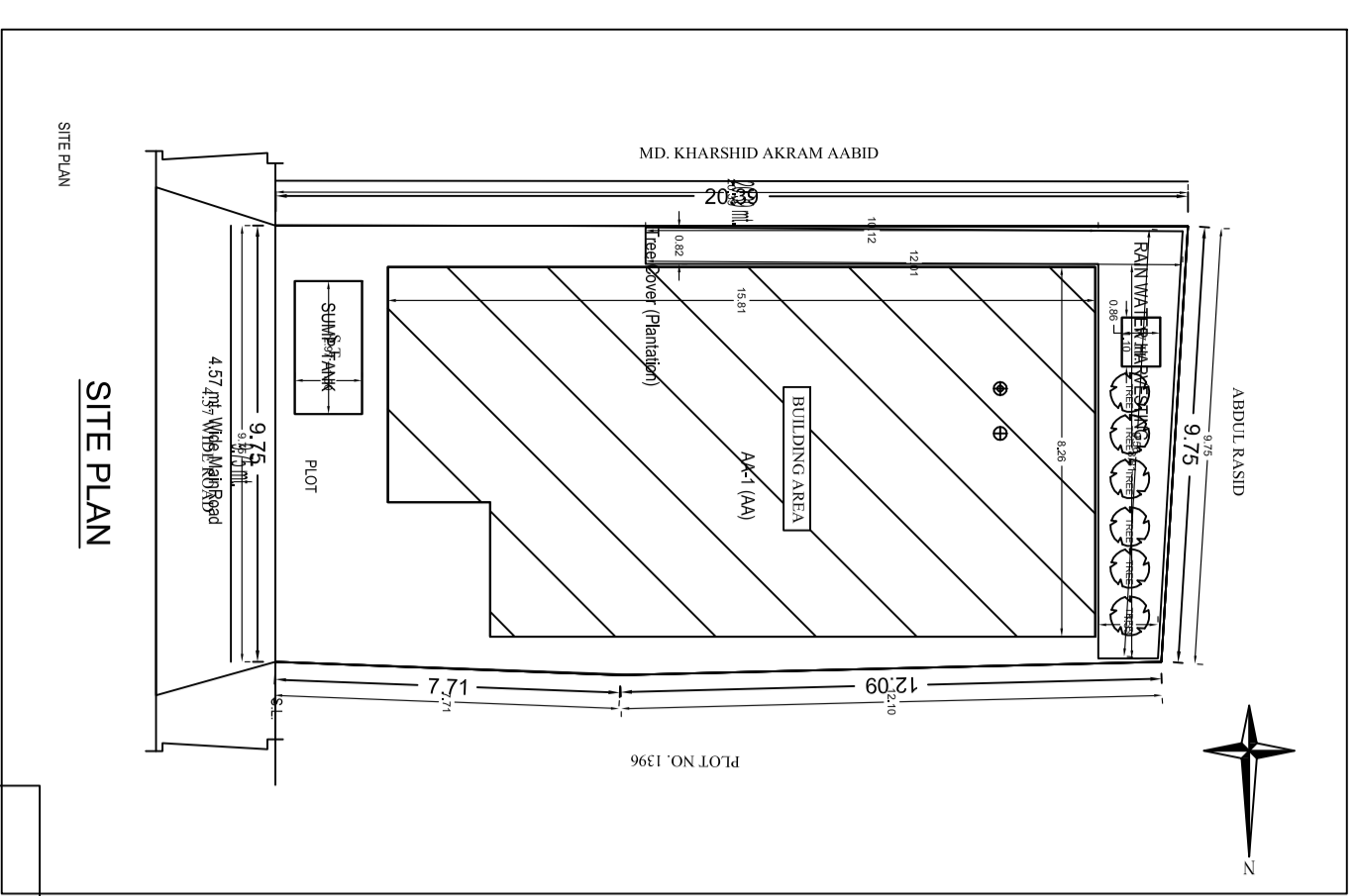
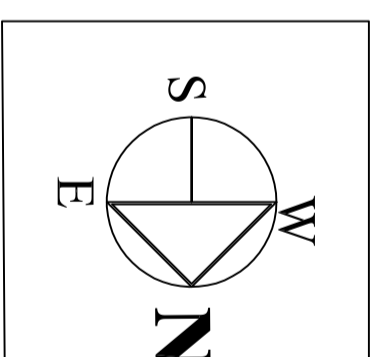
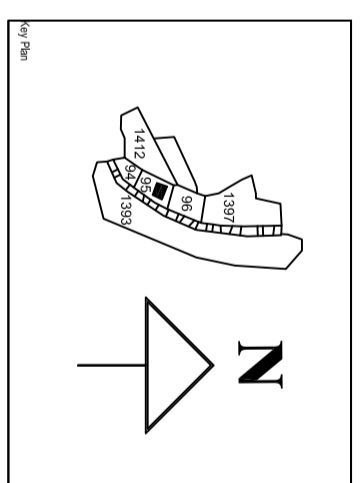
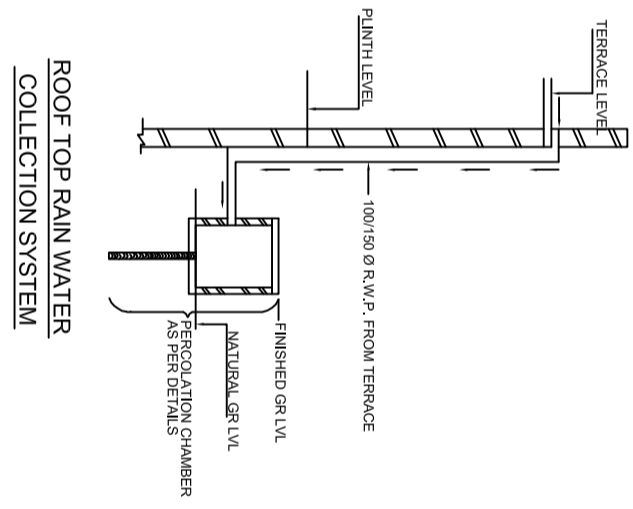
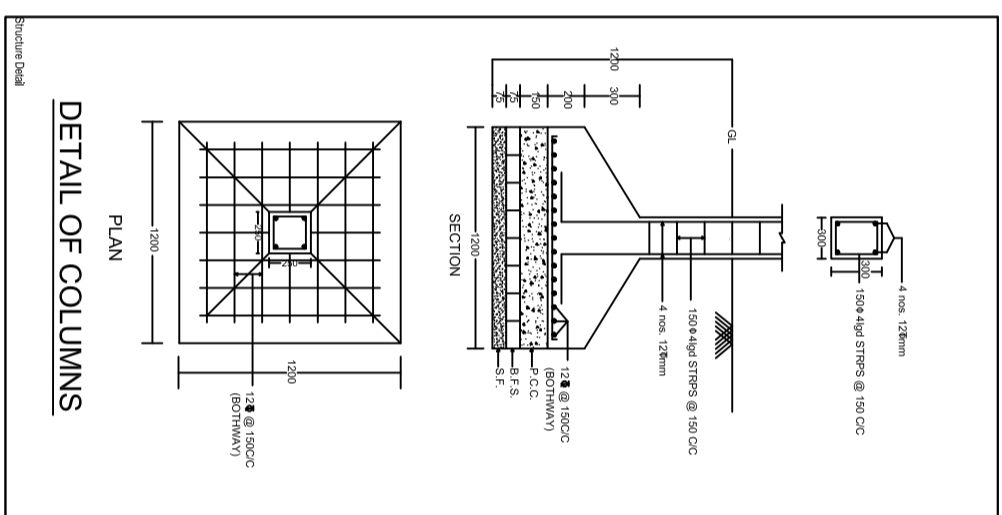
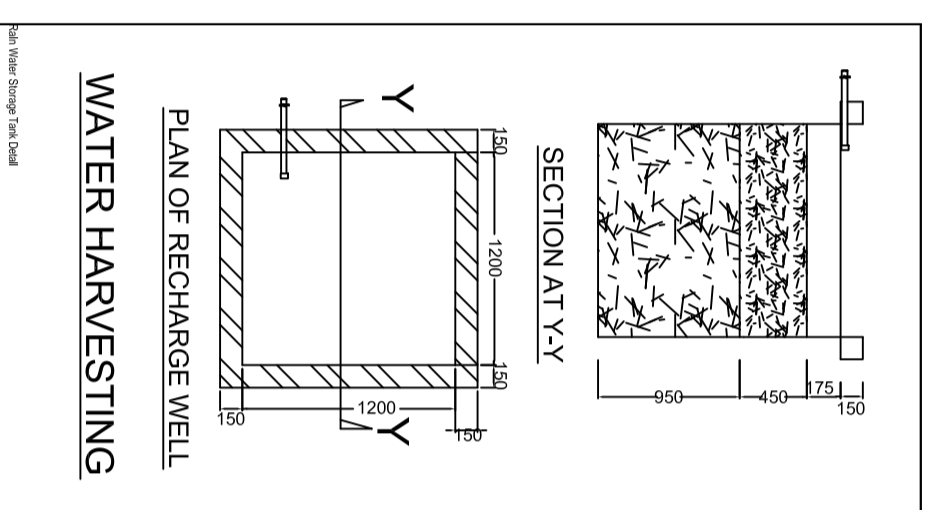
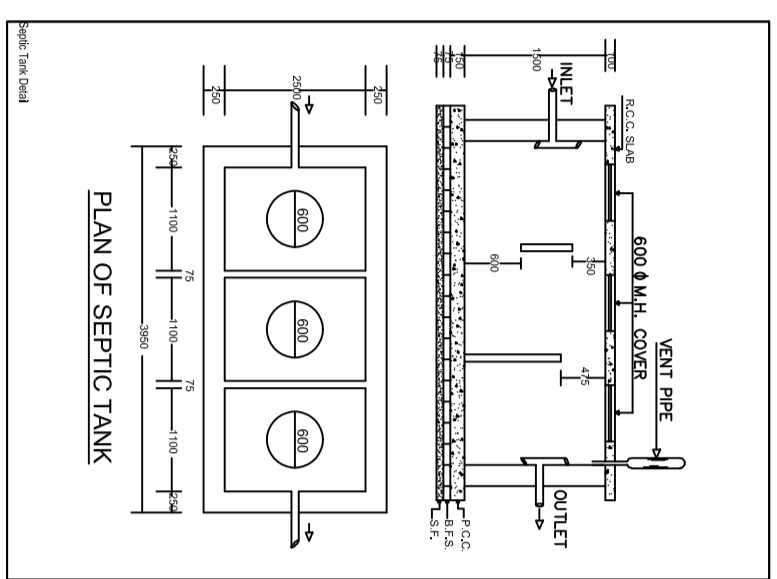
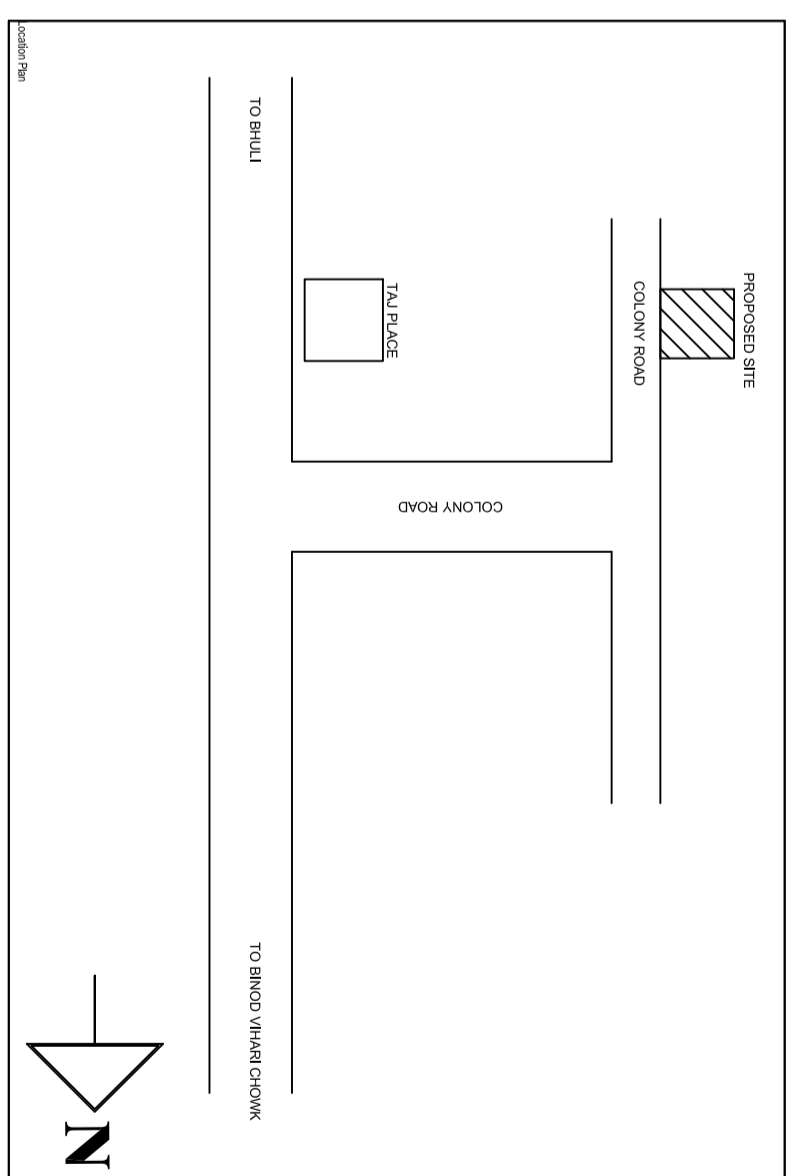
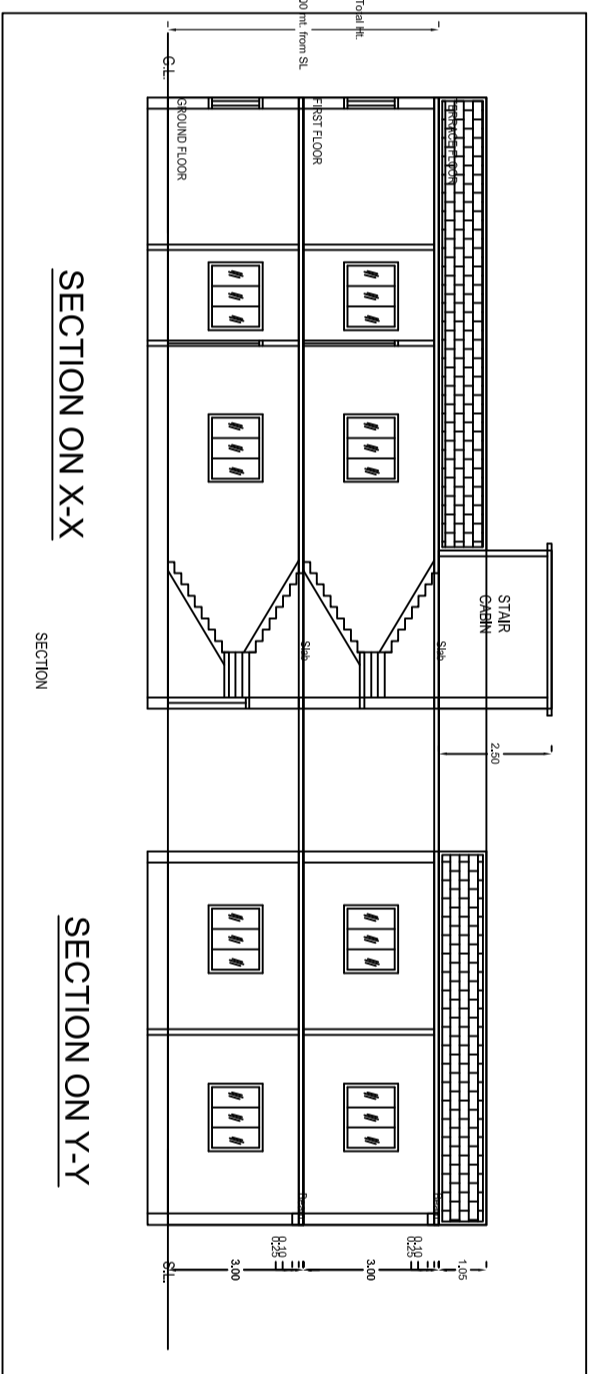
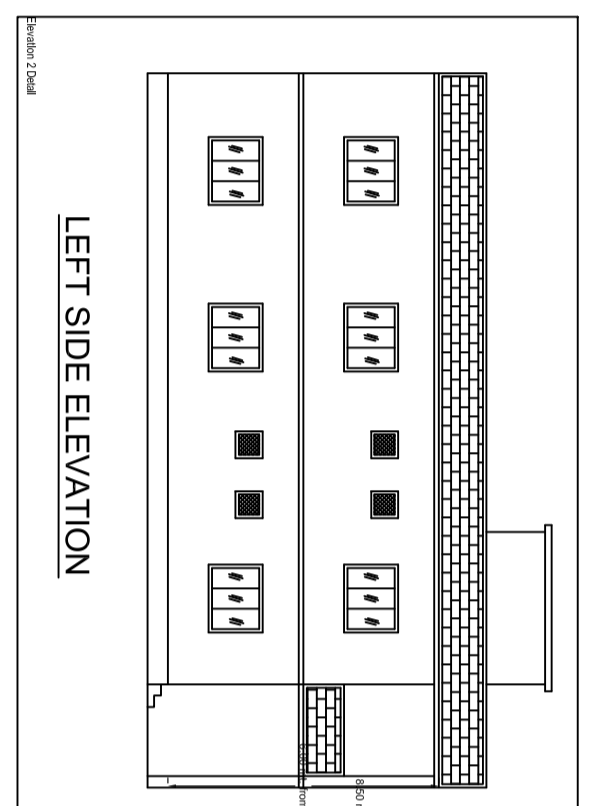
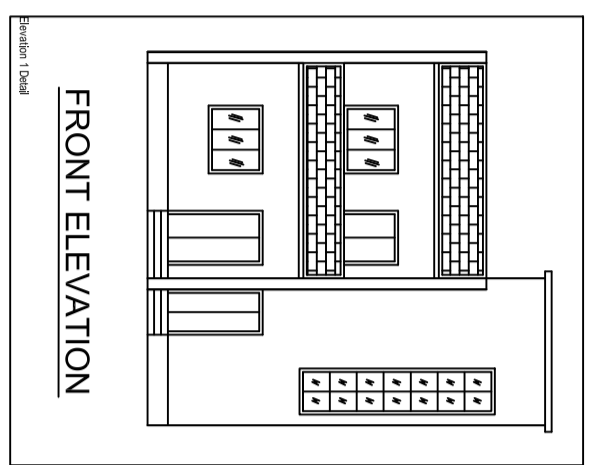

BRIEF SPECIFICATION

FOUNDATION: CEMENT CONCRETE (1:1.5:3)
 BRICK WORK IN FOUNDATION & SUPERSTRUCTURE
 FIRST CLASS BRICK WORK IN CEMENT MORTAR (1:5)
 D.P.C. IN CEMENT CONCRETE (1:2:4)
 FLOOR: 25 I.P.S. OVER 75 P.C.C.
 ROOF: 100 THK. R.C.C. ROOF (1:1.5:3)
 LINTEL: 150 THK. R.C.C. LINTEL (1:1.5:3)
 STAIRS: RISE - 150, TREAD - 250

DETAILS OF AREA

TOTAL AREA (AS PER DEED) 200.39 SQM.
 TOTAL AREA (AS PER SITE) 198.60 SQM.
 GROUND FLOOR AREA 123.77 SQM.
 FIRST FLOOR AREA 123.77 SQM.
 TOTAL COVERED AREA 247.54 SQM.
 % PLINTH AREA 62.32 %
 FAR 1.24

SCHEDULE

D	=	1.200X2.100	W	=	1.800X1.200
D1	=	1.050X2.100	W2	=	0.900X1.200
D2	=	0.900X2.100	V	=	0.800X0.800

TITLE OF DRAWING

PLAN OF PROPOSED RESIDENTIAL BUILDING OF MD ASLAM MANSURI W/O SALIM MIYAN OF BANSJORA BAZAR, P.S. LOYABAD, DIST. DHANBAD UNDER MOUZA PANDARPALA, NO.- 04, KHATA NO.-08, NEW KHATA NO.-548, PLOT NO.- 1395 NEW PLOT NO.- 1089 IN THE DISTT. OF DHANBAD (JHARKHAND).

SIGNATURE OF OWNER

SIGNATURE OF ENGINEER

SCALE: ALL DIMENSION ARE IN METRE

Building: A/AA

Particulars	Area (Sq. M)	Volume (Cu. M)	Rate (Rs.)	Total (Rs.)
FOUNDATION	123.77	123.77	100	12377
BRICK WORK	247.54	247.54	150	37131
FLOOR	247.54	247.54	100	24754
ROOF	247.54	247.54	100	24754
STAIRS	100	100	100	10000
PLINTH	123.77	123.77	100	12377
WATER HARVESTING	100	100	100	10000
SOLAR HEATING SYSTEM	100	100	100	10000
SEPTIC TANK	100	100	100	10000
REINFORCEMENT	100	100	100	10000
CONCRETE	100	100	100	10000
LABOUR	100	100	100	10000
PROFIT	100	100	100	10000
TOTAL	1395	1395	100	139500

UNITED STATES OF AMERICA

Particulars	Area (Sq. M)	Volume (Cu. M)	Rate (Rs.)	Total (Rs.)
FOUNDATION	123.77	123.77	100	12377
BRICK WORK	247.54	247.54	150	37131
FLOOR	247.54	247.54	100	24754
ROOF	247.54	247.54	100	24754
STAIRS	100	100	100	10000
PLINTH	123.77	123.77	100	12377
WATER HARVESTING	100	100	100	10000
SOLAR HEATING SYSTEM	100	100	100	10000
SEPTIC TANK	100	100	100	10000
REINFORCEMENT	100	100	100	10000
CONCRETE	100	100	100	10000
LABOUR	100	100	100	10000
PROFIT	100	100	100	10000
TOTAL	1395	1395	100	139500

Particulars	Area (Sq. M)	Volume (Cu. M)	Rate (Rs.)	Total (Rs.)
FOUNDATION	123.77	123.77	100	12377
BRICK WORK	247.54	247.54	150	37131
FLOOR	247.54	247.54	100	24754
ROOF	247.54	247.54	100	24754
STAIRS	100	100	100	10000
PLINTH	123.77	123.77	100	12377
WATER HARVESTING	100	100	100	10000
SOLAR HEATING SYSTEM	100	100	100	10000
SEPTIC TANK	100	100	100	10000
REINFORCEMENT	100	100	100	10000
CONCRETE	100	100	100	10000
LABOUR	100	100	100	10000
PROFIT	100	100	100	10000
TOTAL	1395	1395	100	139500