

SCHEDULE OF DOOR:

BUILDING NAME	NAME	LENGTH	HEIGHT	NOS
A (A)	D	0.75	2.10	04
A (A)	D	0.91	2.10	04
A (A)	D	1.07	2.10	16

SCHEDULE OF WINDOW/VENTILATION:

BUILDING NAME	NAME	LENGTH	HEIGHT	NOS
A (A)	V	0.61	1.20	04
A (A)	W	1.22	1.20	22
A (A)	W	1.52	1.20	04

Building :A (A)

Floor Name	Total Built Up Area (Sq.mt.)	Proposed FAR Area (Sq.mt.)	Total FAR Area (Sq.mt.)	Total Consumed Additional FAR Area (Sq.mt.)	Tnmt (No.)
Ground Floor	123.39	123.39	123.39	123.39	01
First Floor	123.39	123.39	123.39	123.39	00
Terrace Floor	0.00	0.00	0.00	0.00	00
Total :	246.78	246.78	246.78	246.78	01
Total Number of Same Buildings	1				
Total :	246.78	246.78	246.78	246.78	01

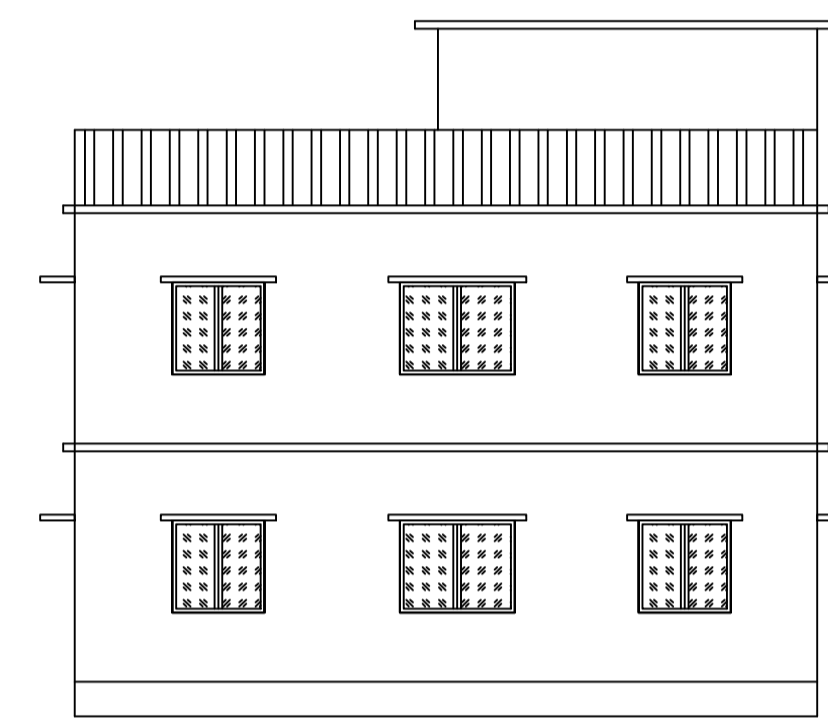
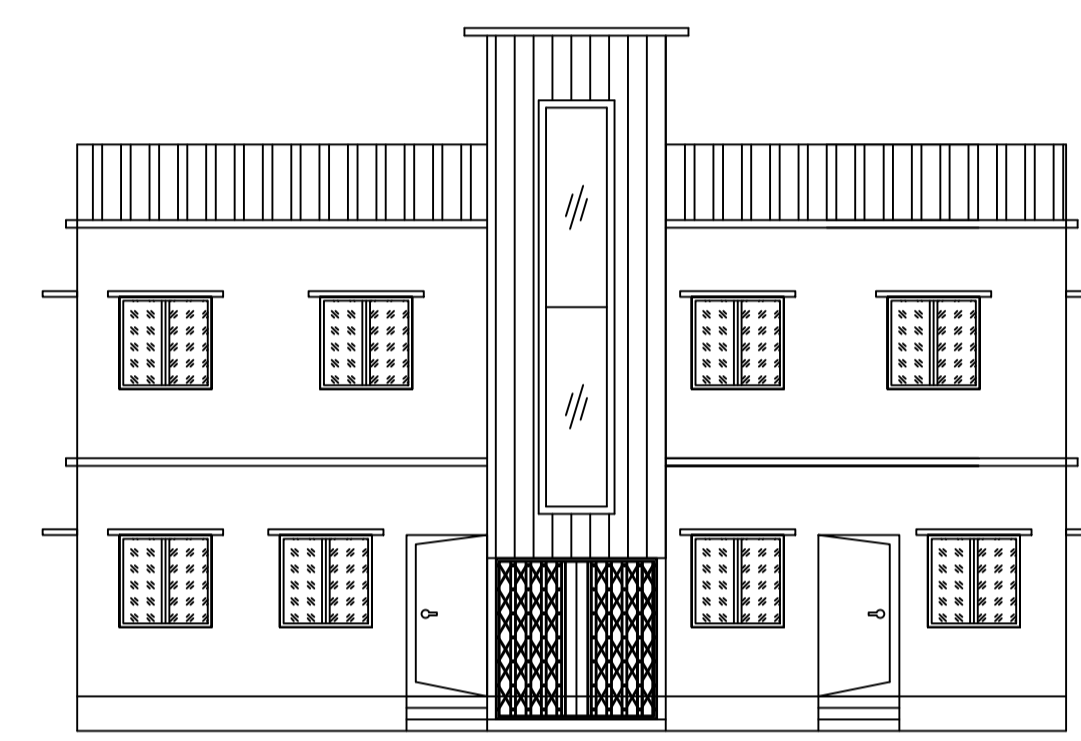
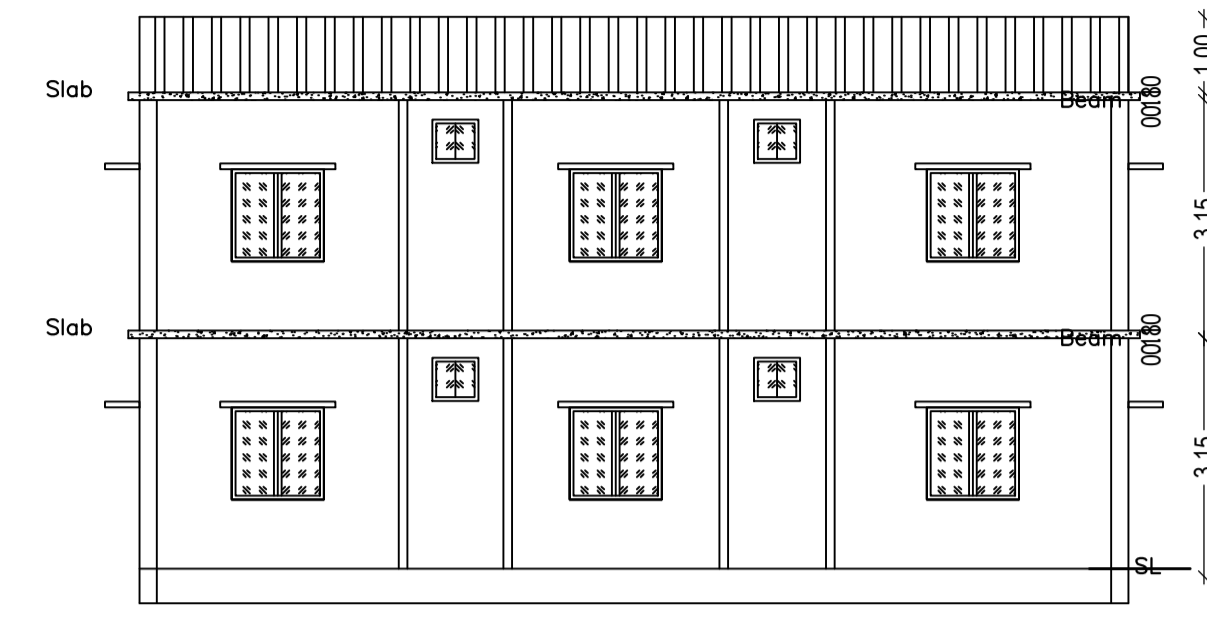
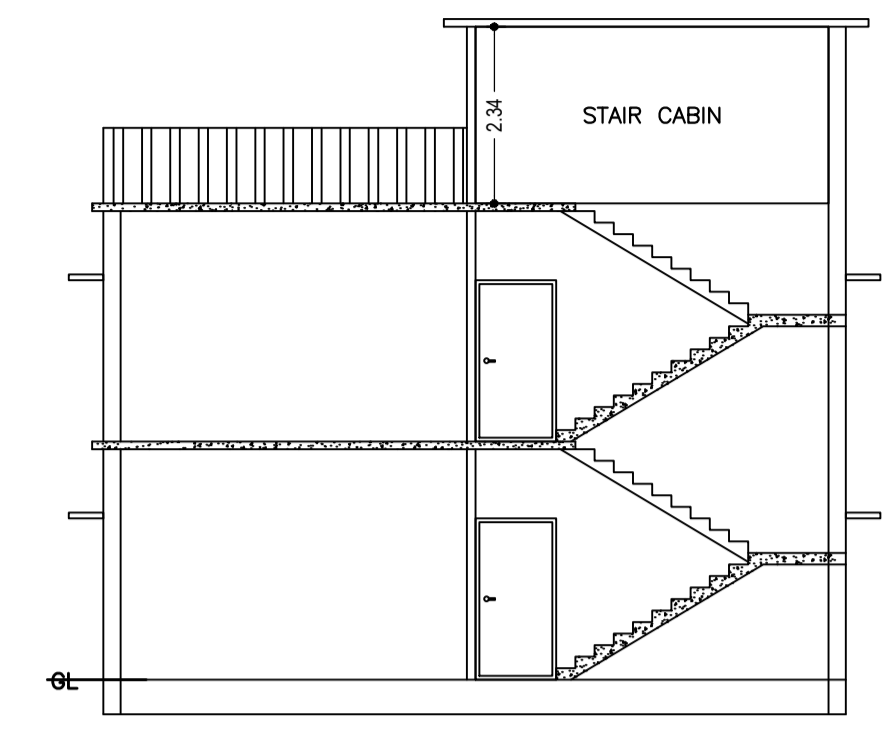
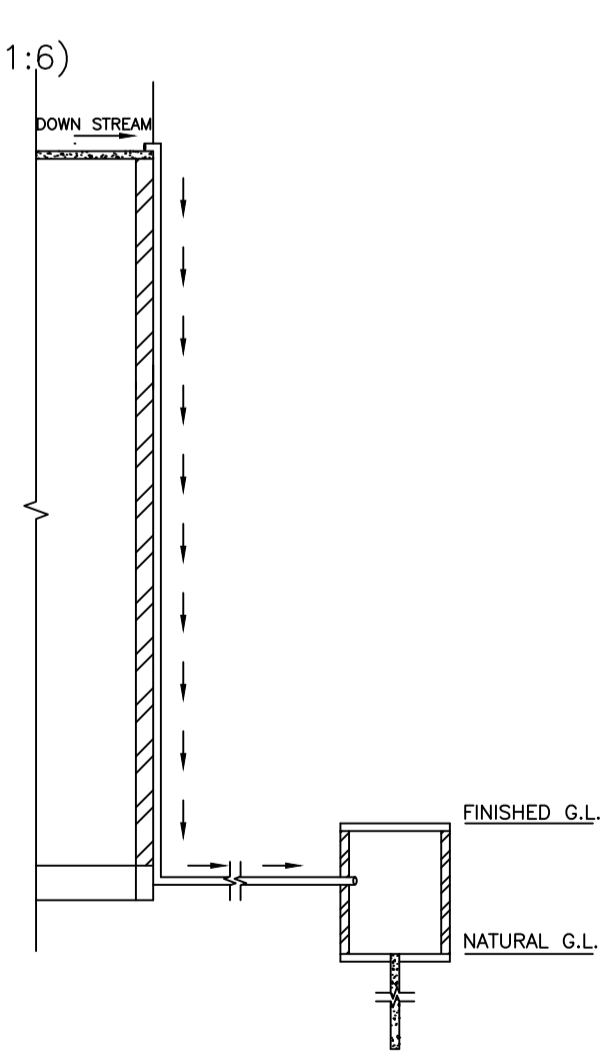
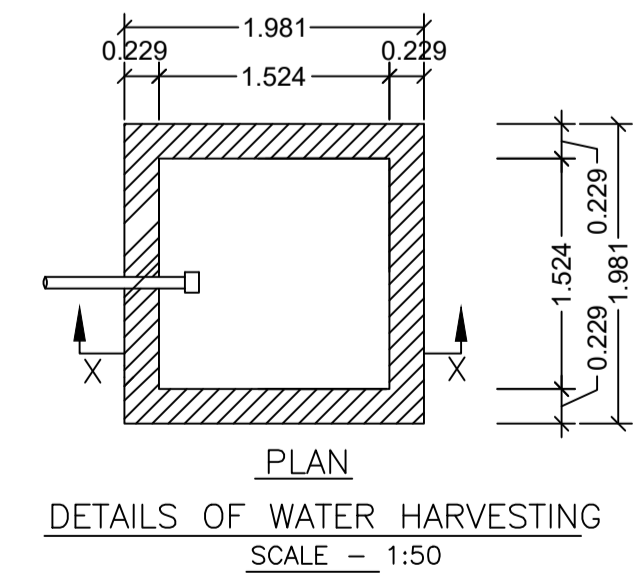
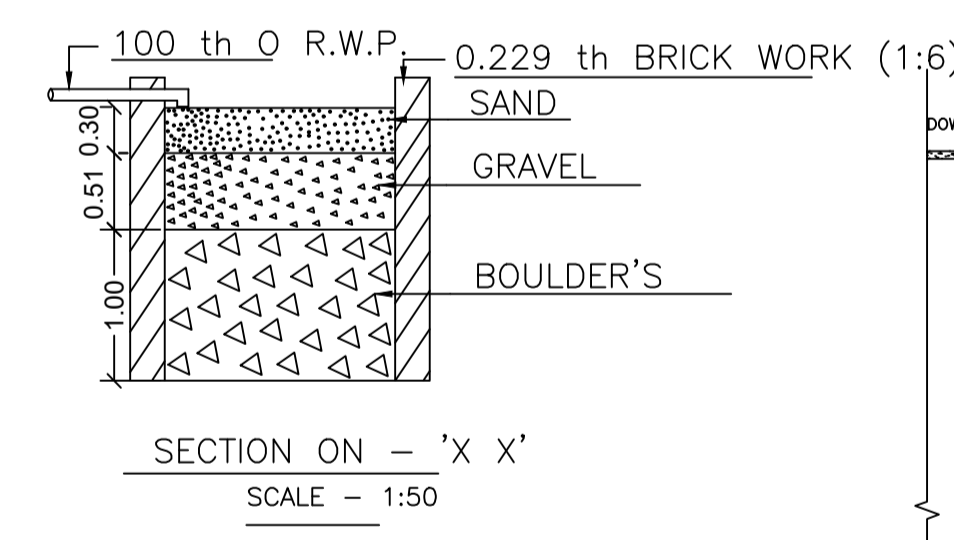
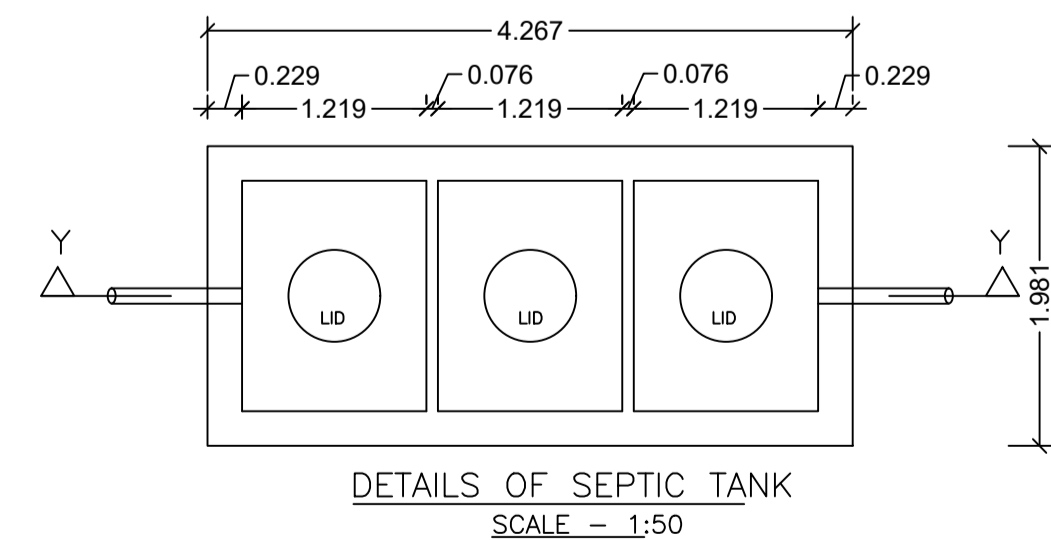
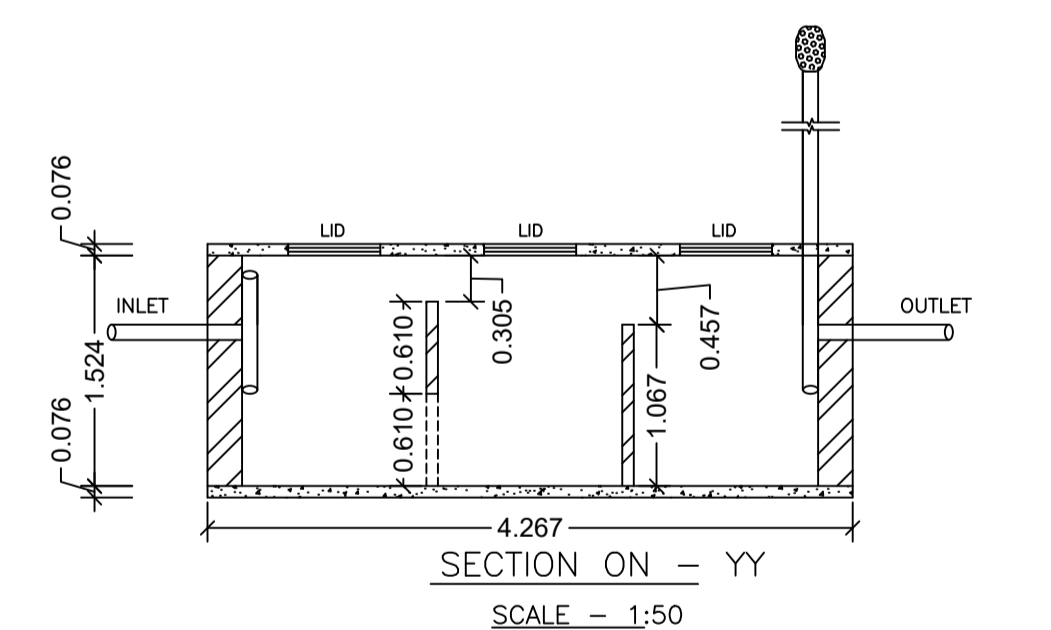
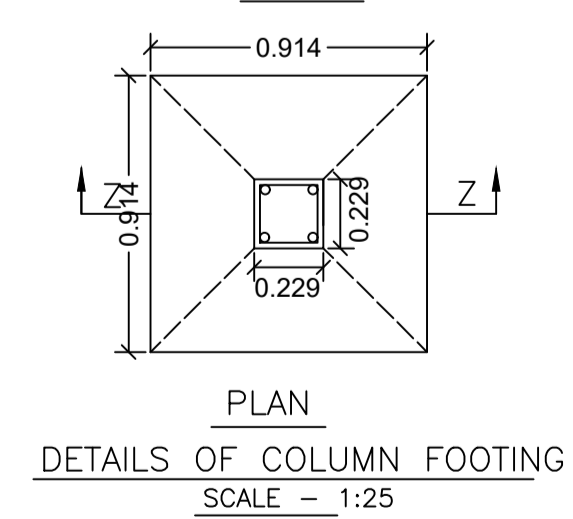
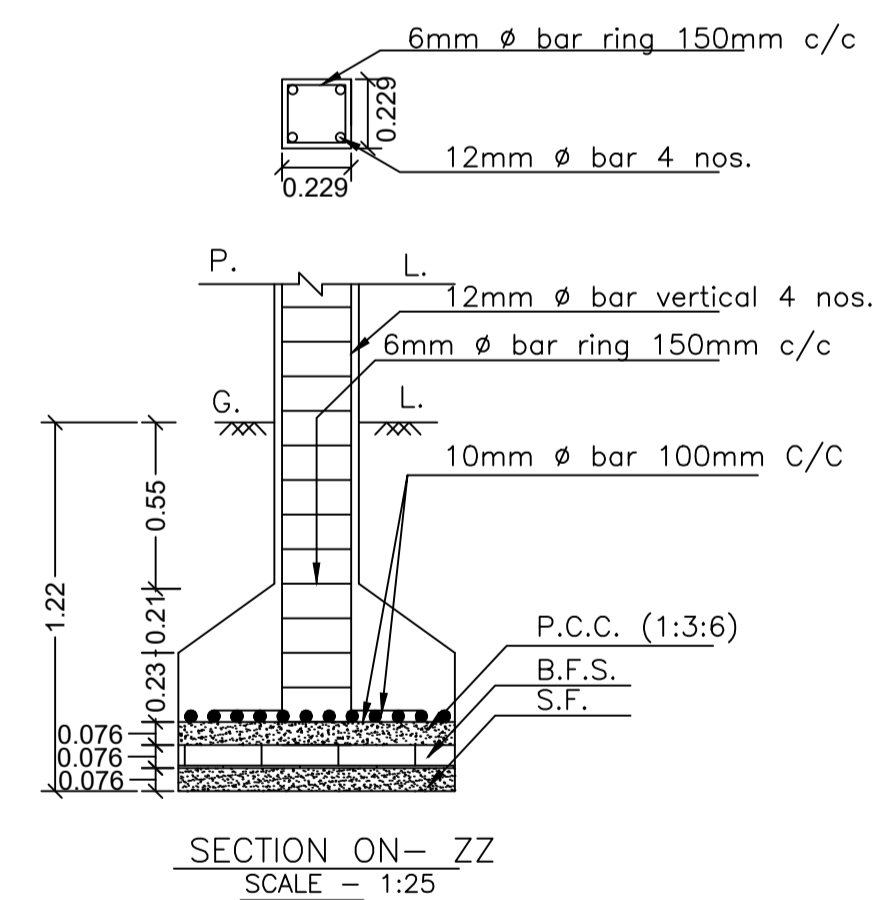

Proposal Basic Information

Proposal File No.	DMC/BP/0401/W24/2023
Owner Name	1) YOGENDRA KUMAR YADAV 2) ANITA DEVI
Khata No	OLD-114, NEW-514
Plot No	OLD-3534&3536, NEW-2586/3326
Village Name	Saraidhela
Use	Residential
SubUse	Bungalow/ Dwelling / Non Apartment

AREA STATEMENT

AREA OF PLOT (Minimum)	(A)	SQ.MT.
NET AREA OF PLOT(Gross Plot Area)	(A)	199.16
- Deduction from Gross Plot area)	(A-Deductions)	199.16
Deduction for Balance Plot Area(from Gross Plot Area)		
Common Plot		17.33
Total		17.33
BALANCE AREA OF PLOT(Net Plot Area - Recreational/Amenity space)	(A-Deductions)	181.82
PLOT AREA FOR COVERAGE(Net Plot Area)	(A-Deductions)	199.16
Plot Area for FAR (Net Plot Area + Road Widening Area)	(A-Deductions)	199.16
COVERAGE CHECK		
Permissible Coverage area (70.00 %)		139.41
Proposed Coverage Area (61.96 %)		123.39
Total Prop. Coverage Area (61.96 %)		123.39
Balance coverage area (8.04 %)		16.02
FAR CHECK		
Perm. FAR Area (1.500)		298.74
Total Perm. FAR area		298.74
Residential FAR		246.77
Proposed FAR Area		246.77
Total Proposed FAR Area		246.77
Consumed FAR (Factor)		1.24
Balance FAR Area		51.97
BUILT UP AREA CHECK		
Total Proposed BuiltUp Area		246.78
ARCHITECT (Regd)	AJAY KUMAR KESARI	
ENGINEER (Regd)		
SUPERVISOR (Regd)		
OWNER (Regd)	1) YOGENDRA KUMAR YADAV 2) ANITA DEVI	
DEVELOPMENT AUTHORITY	LOCAL BODY	

COLOR INDEX

PLOT BOUNDARY	Black
ABUTTING ROAD	Red
PROPOSED CONSTRUCTION	Green
COMMON PLOT	Blue
ROAD WIDENING AREA	Yellow
EXISTING (To be retained)	Orange
EXISTING (To be demolished)	Pink

Buildingwise Floor FAR Details

Floor Name	Building Name A (A)		Total	
	Proposed Built Up Area (Sq.mt.)	Proposed FAR Area (Sq.mt.)	Total Proposed Built Up Area (Sq.mt.)	Total FAR Area (Sq.mt.)
Ground Floor	123.39	123.39	123.39	123.39
First Floor	123.39	123.39	123.39	123.39
Terrace Floor	0.00	0.00	0.00	0.00
Total :	246.78	246.78	246.78	246.78

Building USE/SUBUSE Details

Building Name	Building Use	Building SubUse	Building Structure
A (A)	Residential	Bungalow/ Dwelling / Non Apartment	Non-Highrise

FAR & Tenement Details (Table 4c-1)

Building	No. of Same Bldg	Total Built Up Area (Sq.mt.)	Proposed FAR Area (Sq.mt.)	Total FAR Area (Sq.mt.)	Total Consumed Additional FAR Area (Sq.mt.)	Tnmt (No.)
A (A)	1	246.78	246.78	246.78	246.78	01
Grand Total :	1	246.78	246.78	246.78	246.78	01

UnitBUA Table for Building :A (A)

FLOOR	Name	UnitBUA Type	UnitBUA Area	Carpet Area	No. of Rooms	No. of Tenement
GROUND FLOOR PLAN	SPLIT A	FLAT	246.77	246.71	11	1
FIRST FLOOR PLAN	SPLIT A	FLAT	0.00	0.00	11	0
Total:	-	-	246.77	246.71	22	1

LTP NAME AND SIGNATURE	STRUCTURAL ENG'S NAME AND SIGNATURE	BUILDER NAME AND SIGNATURE	DIGITAL SIGNATURE
AJAY KUMAR KESARI DMC/ENG/0007/2021			

Proposal Basic Information

Proposal File No.	DMC/BP/0401/W24/2023
Owner Name	1) YOGENDRA KUMAR YADAV 2) ANITA DEVI
Khata No	OLD-114, NEW-514
Plot No	OLD-3534&3536, NEW-2586/3326
Village Name	Saraidhela
Use	Residential
SubUse	Bungalow/ Dwelling / Non Apartment

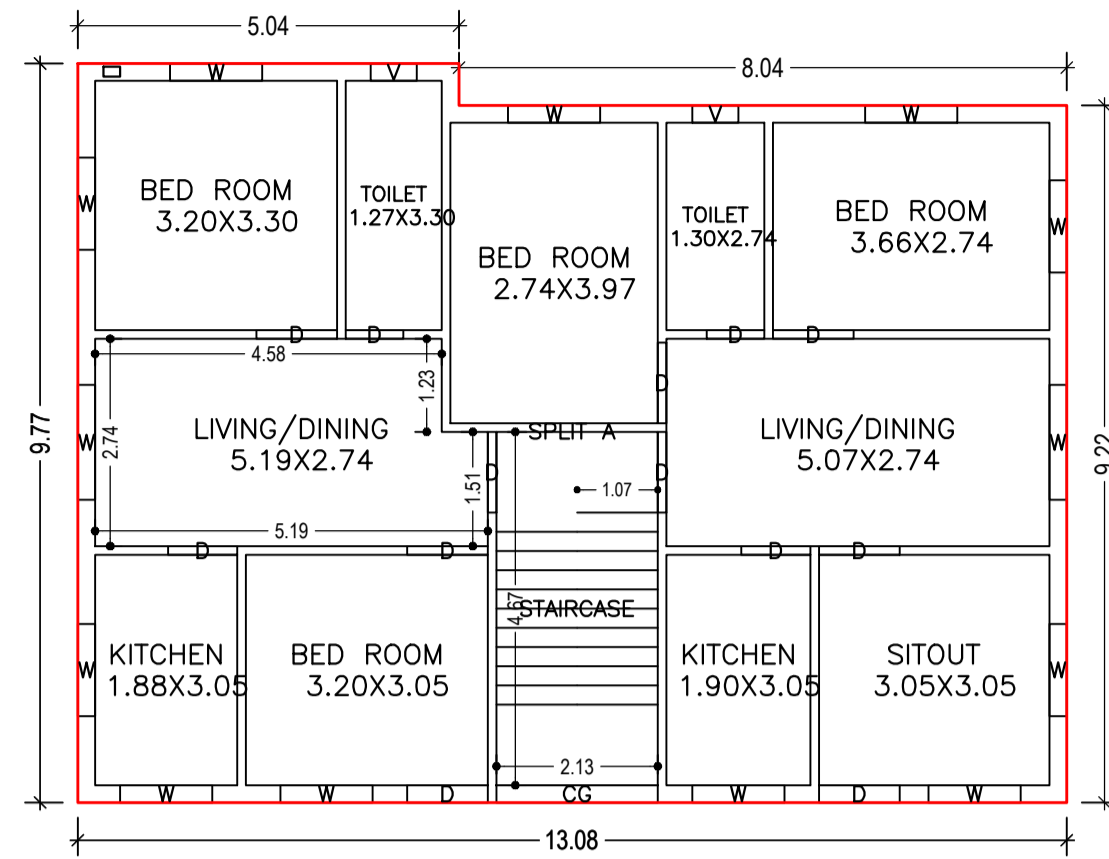

GROUND FLOOR PLAN
(Proposed)
(SCALE 1:100)

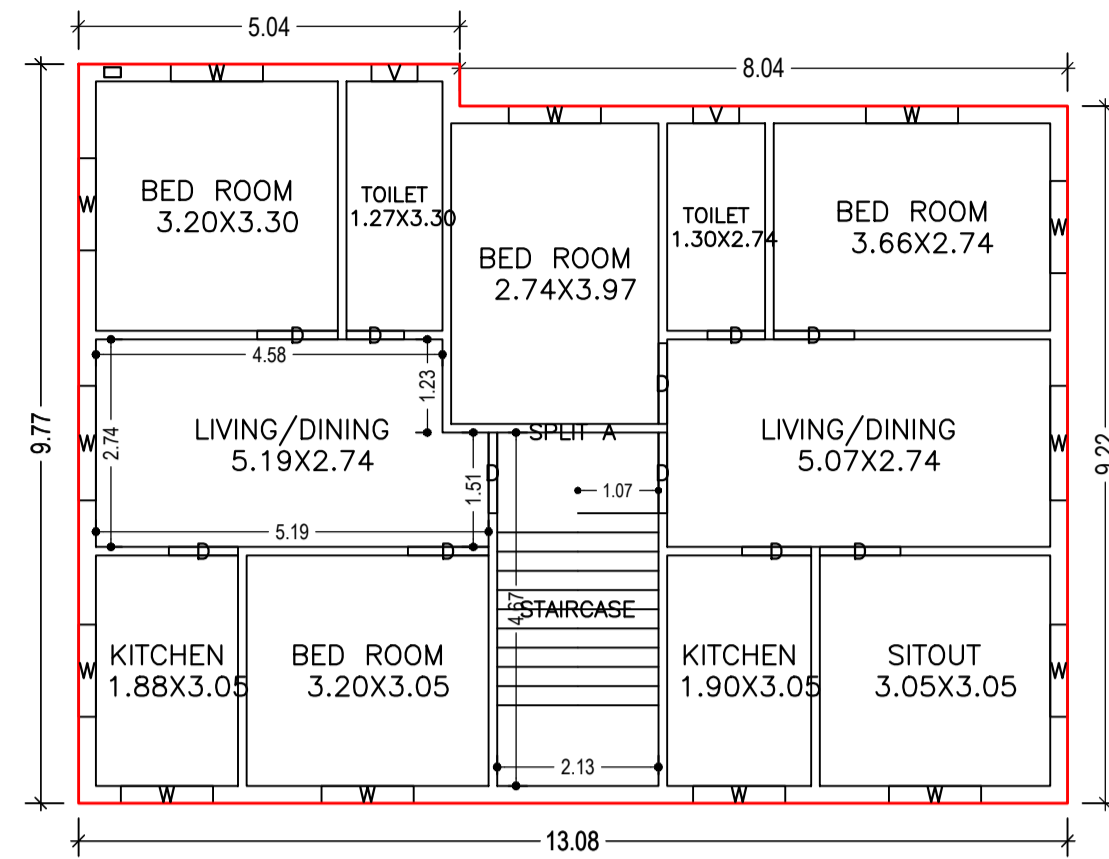

FIRST FLOOR PLAN
(Proposed)
(SCALE 1:100)

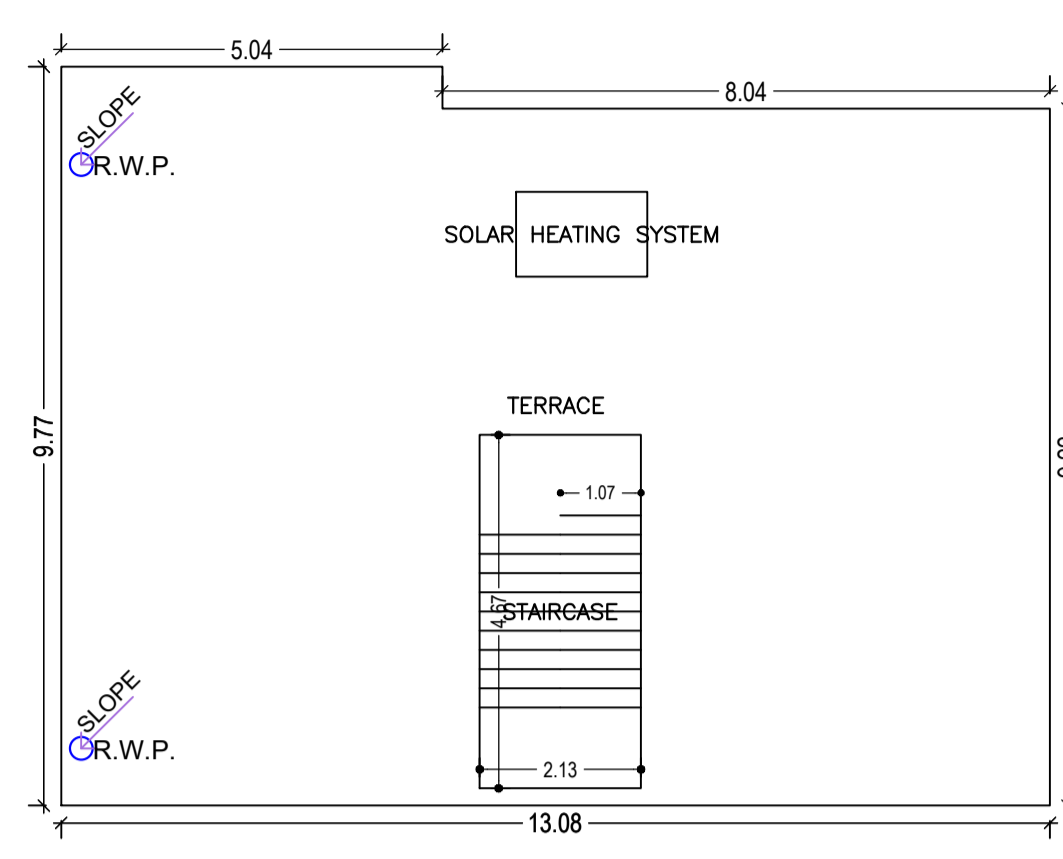

TERRACE FLOOR PLAN
(SCALE 1:100)

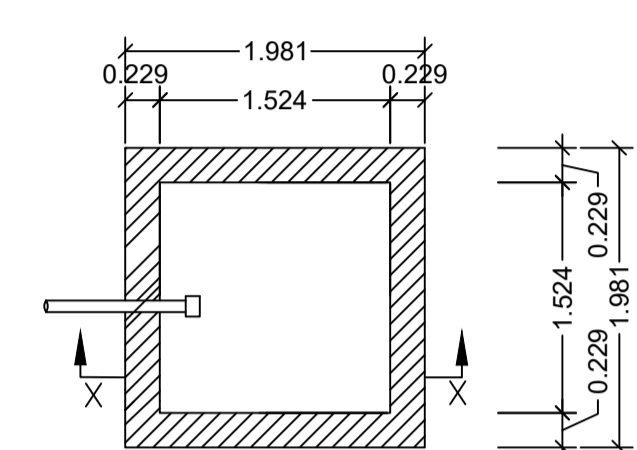
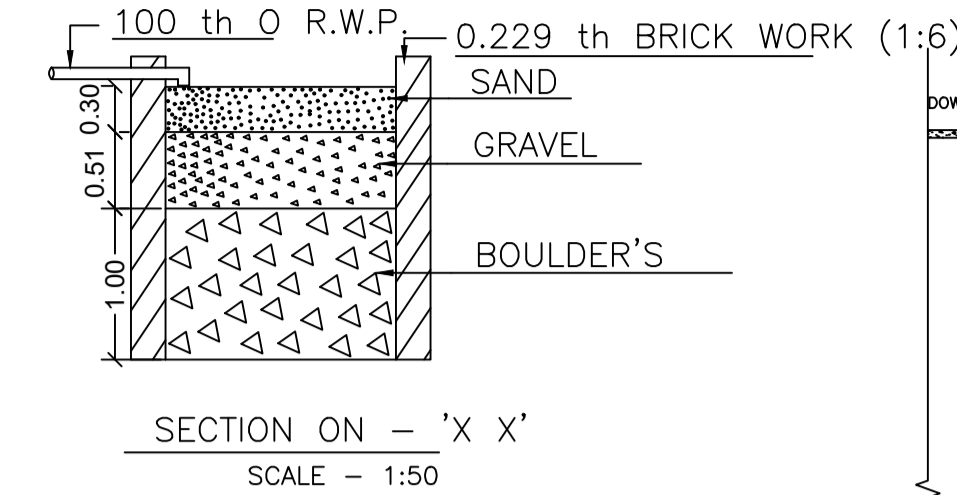

DETAILS OF WATER HARVESTING
SCALE - 1:50

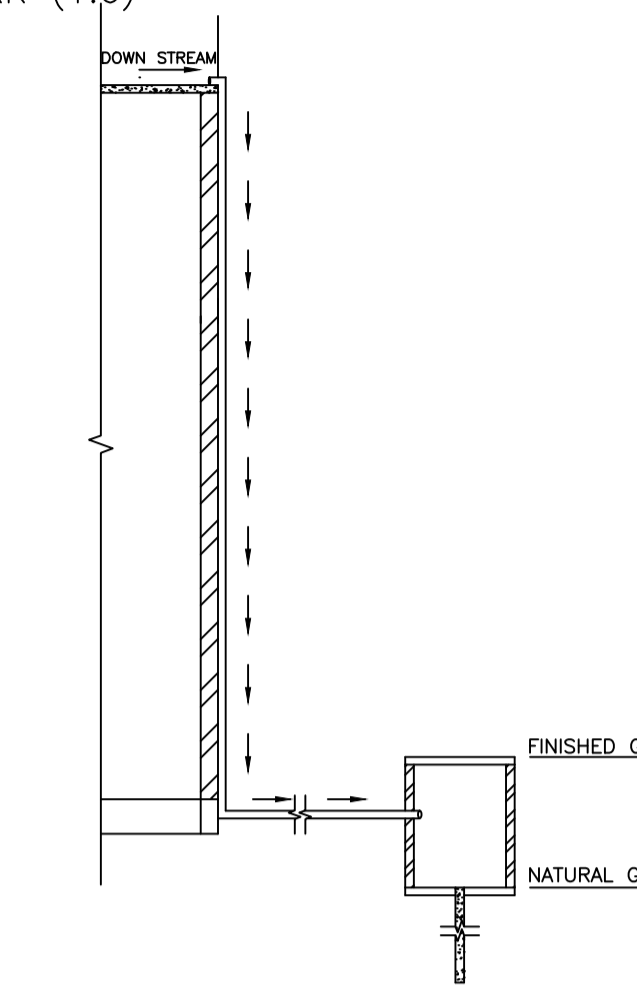

ROOF TOP RAIN WATER
COLLECTION SYSTEM
SCALE: 1:96 (1"=8'-0")

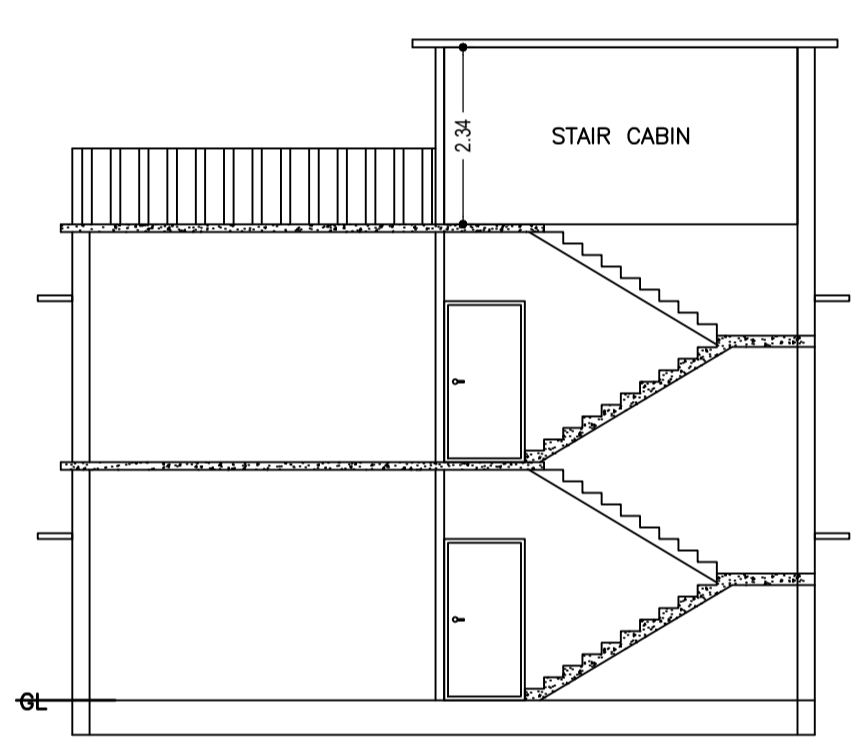

SECTION ON: 'A-A'
SCALE - 1:100

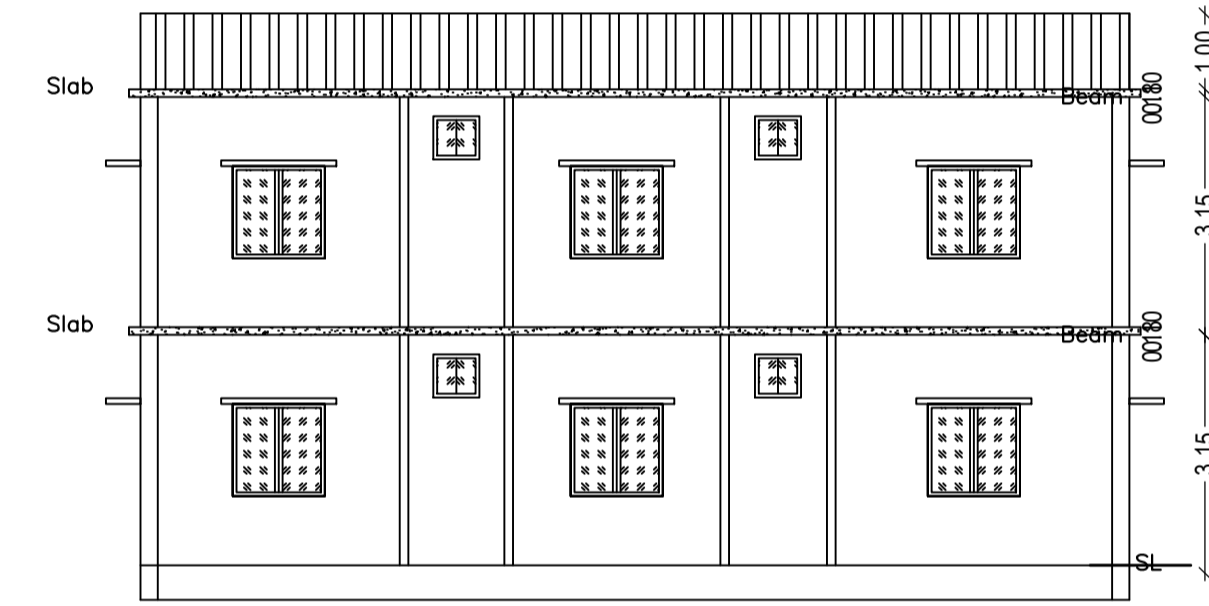

SECTION ON: 'B-B'
SCALE - 1:100

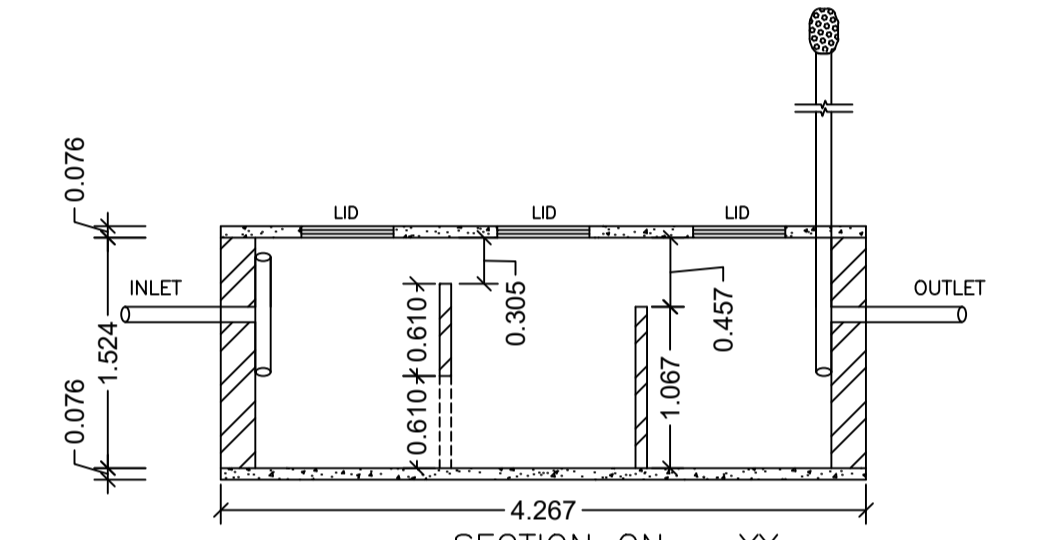

SECTION ON - YY
SCALE - 1:50

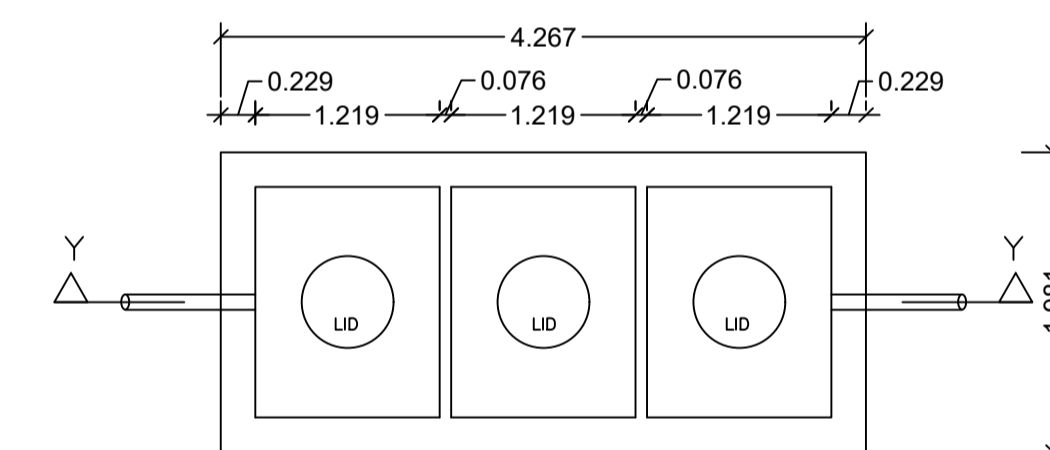

DETAILS OF SEPTIC TANK
SCALE - 1:50

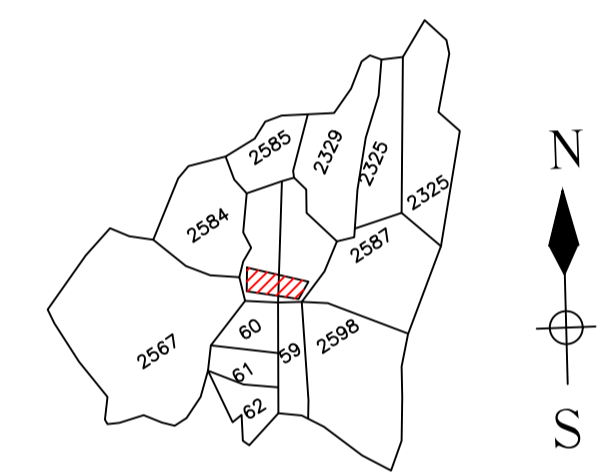

KEY PLAN
SCALE - NTS

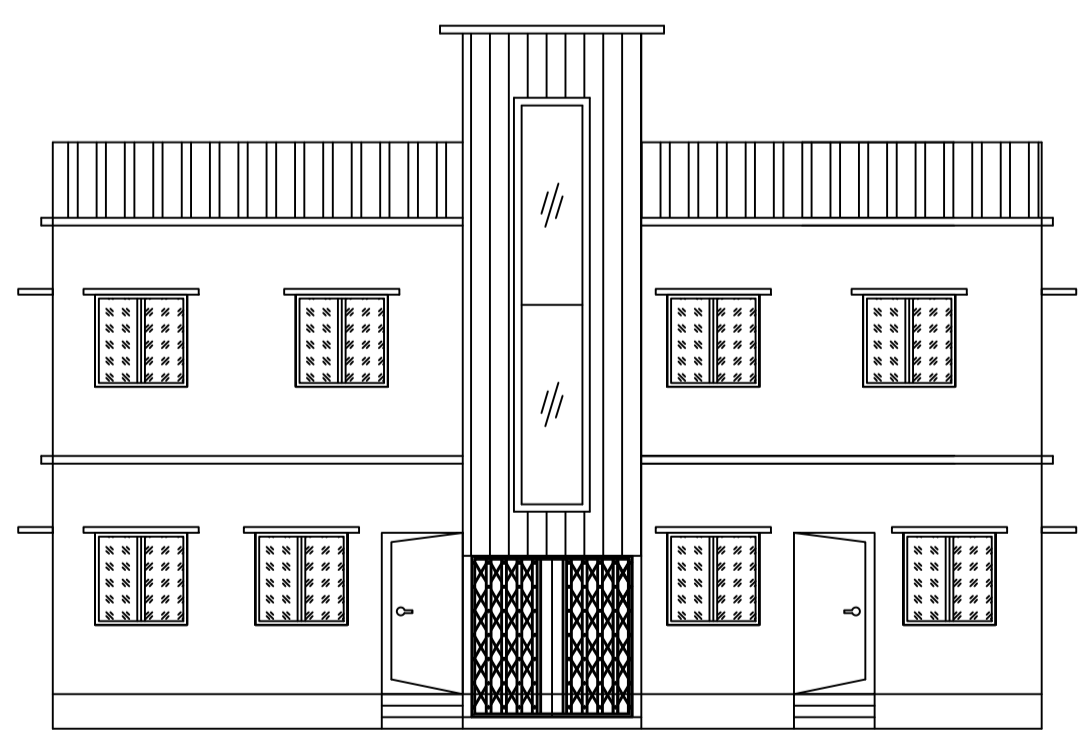

FRONT ELEVATION
SCALE - 1:100

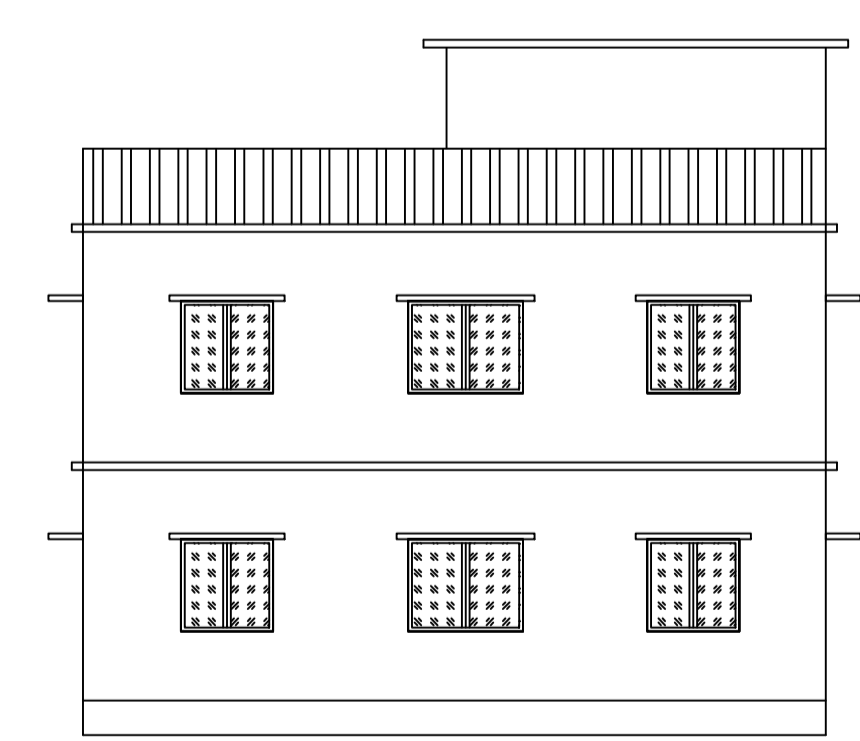

LEFT SIDE ELEVATION
SCALE - 1:100

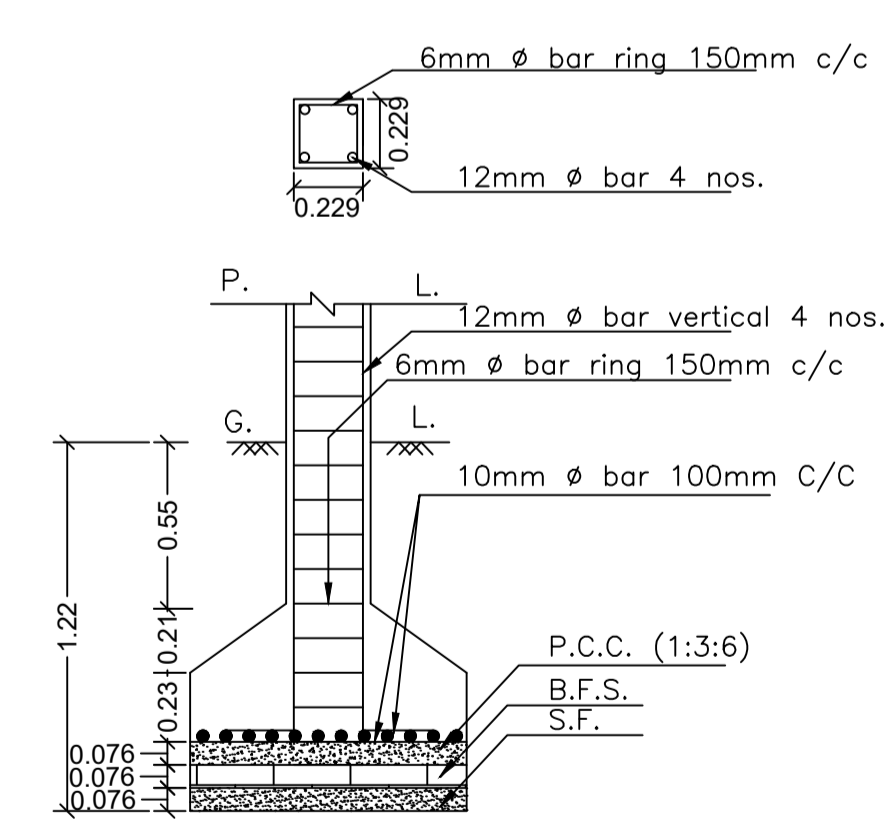

SECTION ON - ZZ
SCALE - 1:25

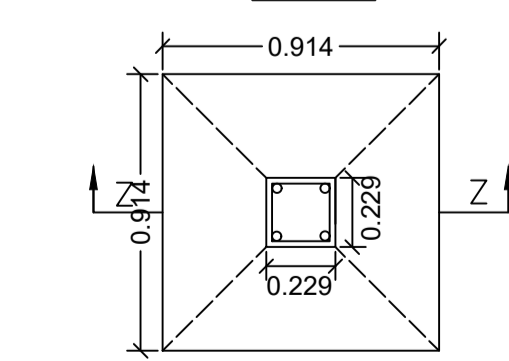

PLAN
DETAILS OF COLUMN FOOTING
SCALE - 1:25

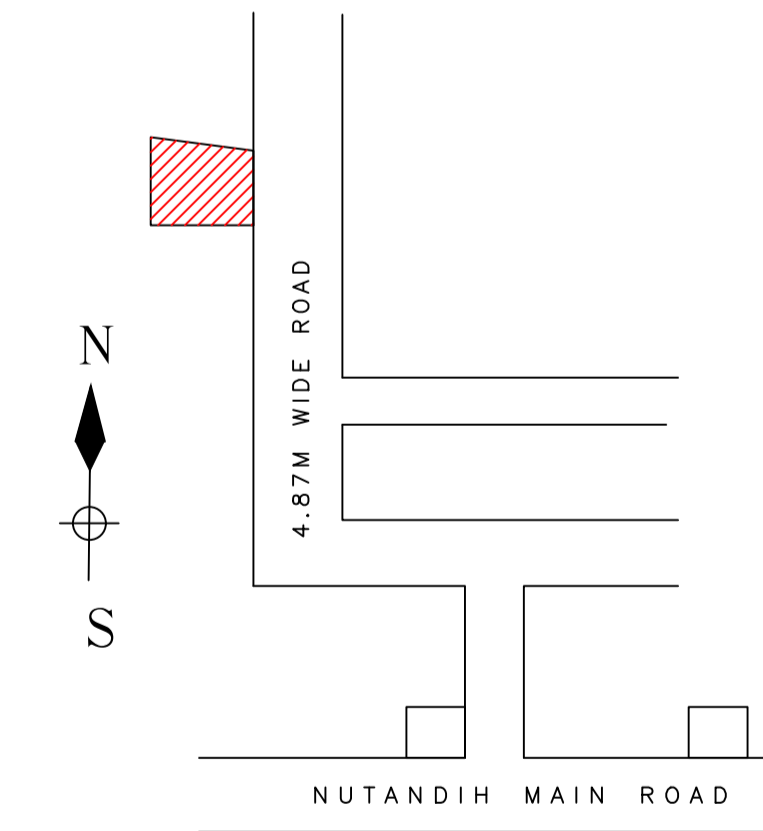

LOCATION PLAN
SCALE - NTS

LTP NAME AND SIGNATURE	STRUCTURAL ENG'S NAME AND SIGNATURE	BUILDER NAME AND SIGNATURE	DIGITAL SIGNATURE
AJAY KUMAR KESARI DMC/ENG/0007/2021			