

Project Title :-AMNA KHATOON

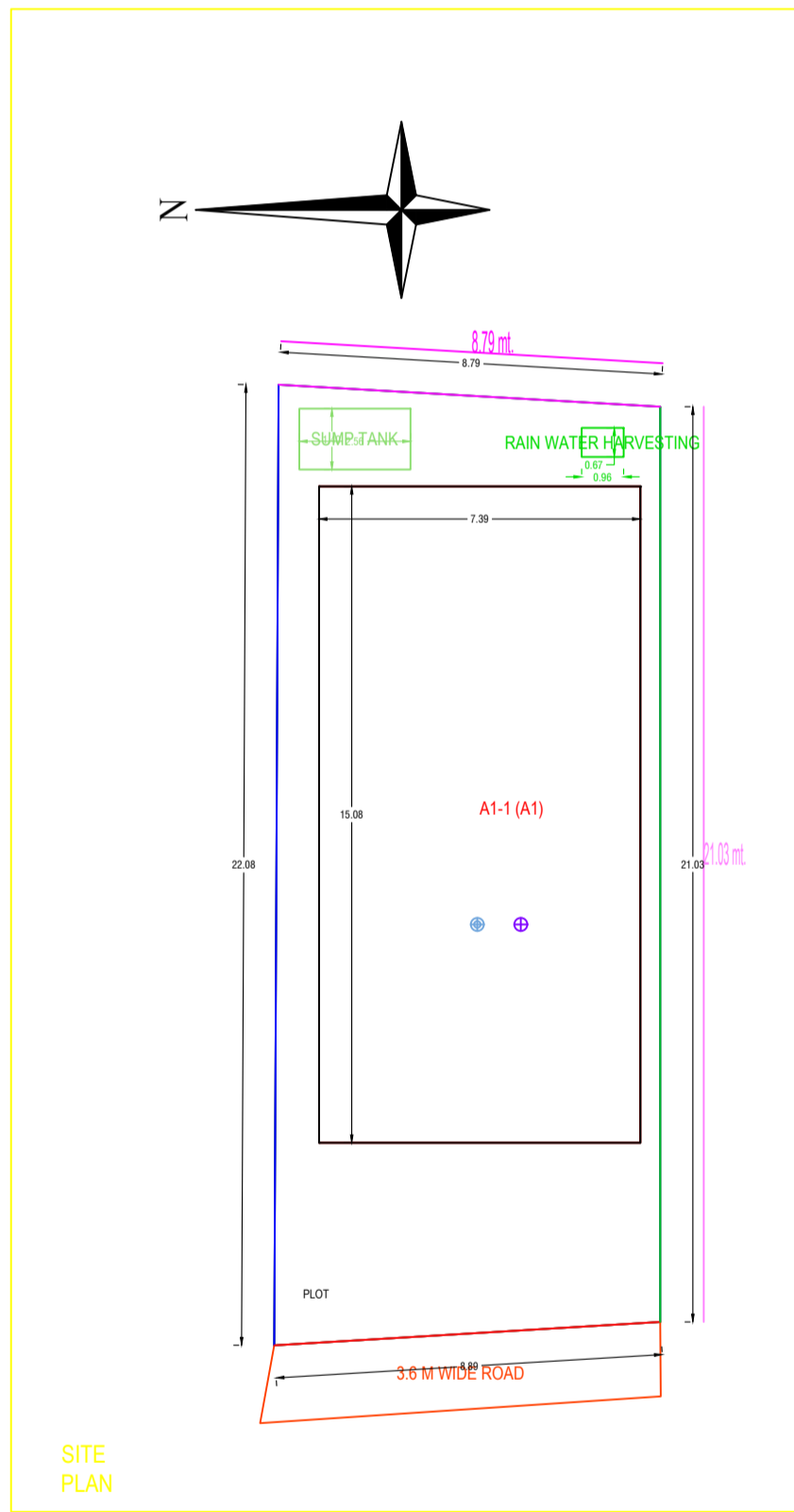
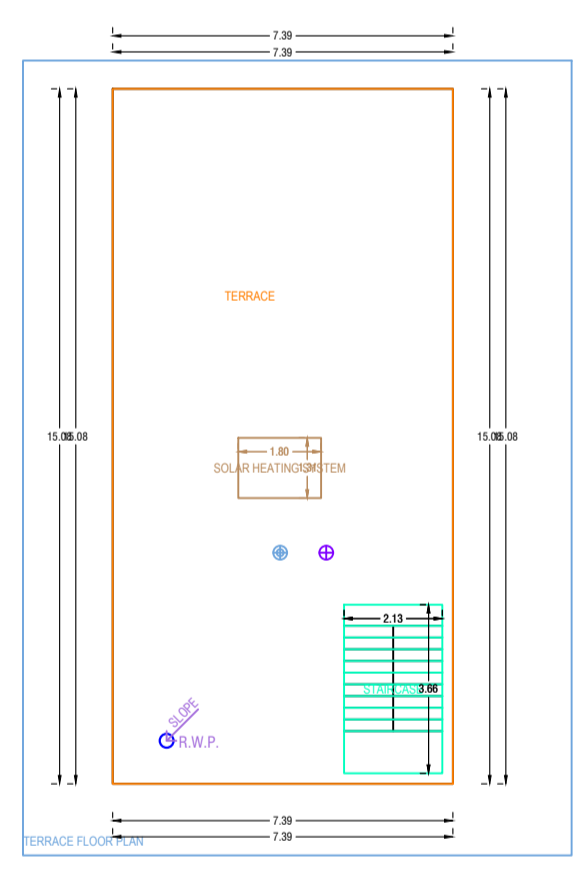
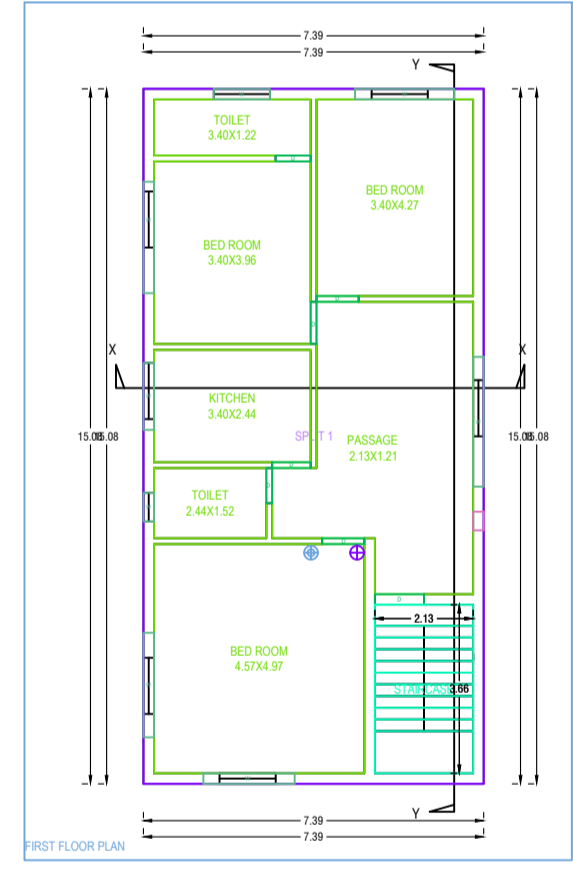
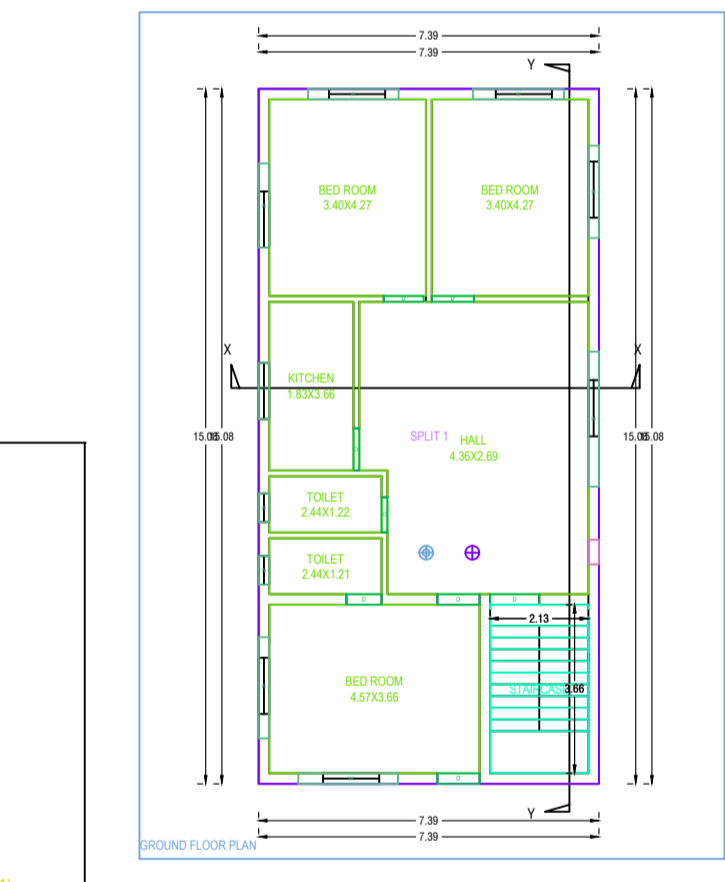
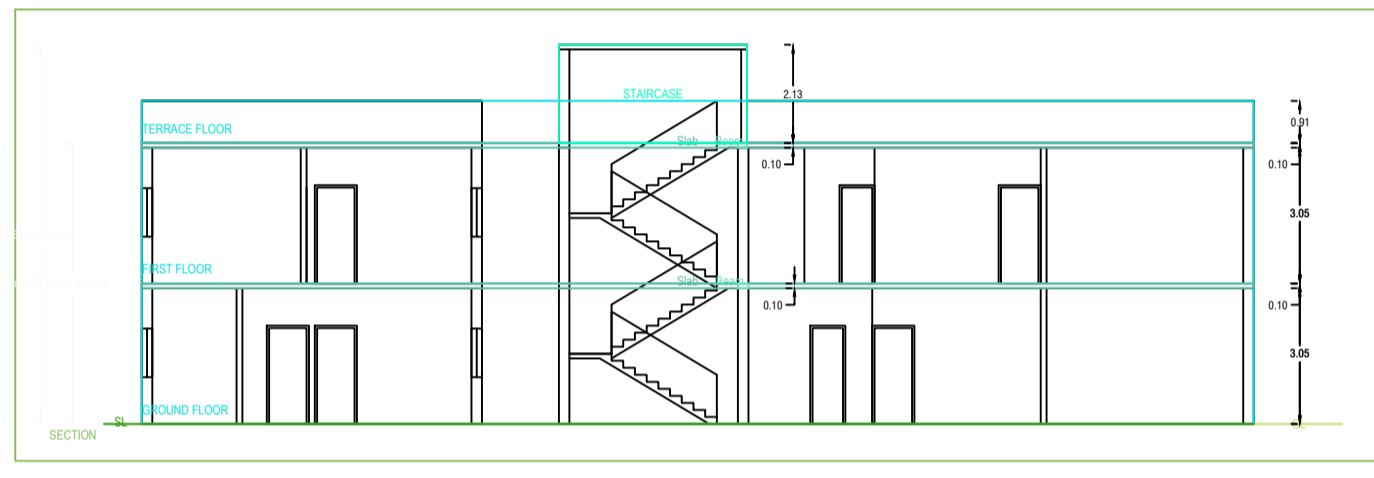
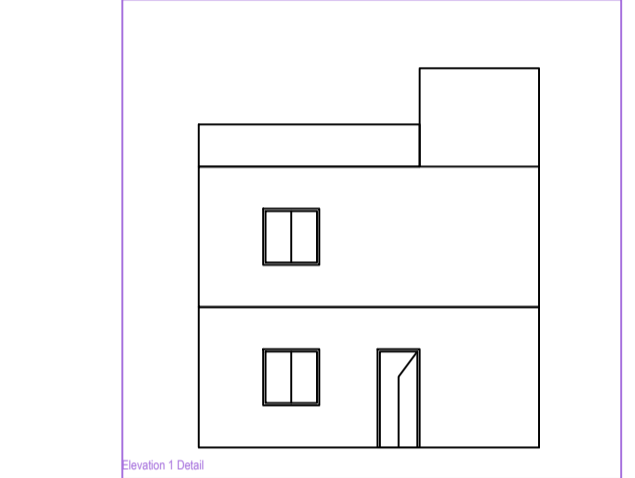
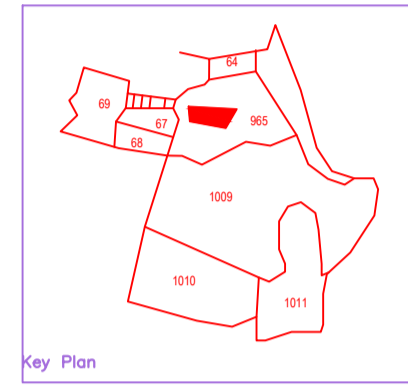
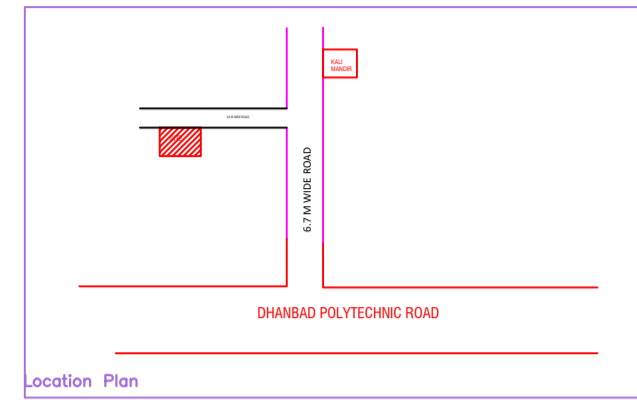
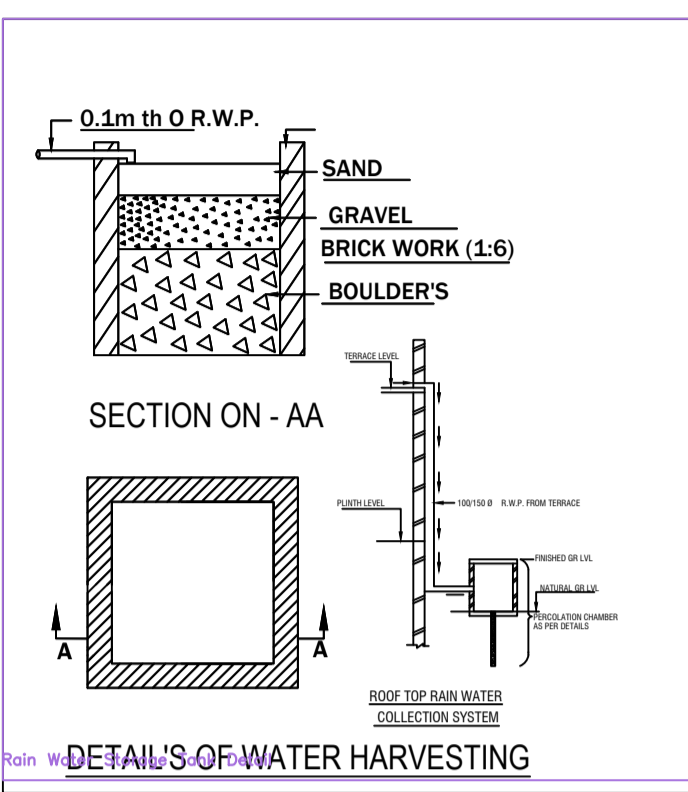
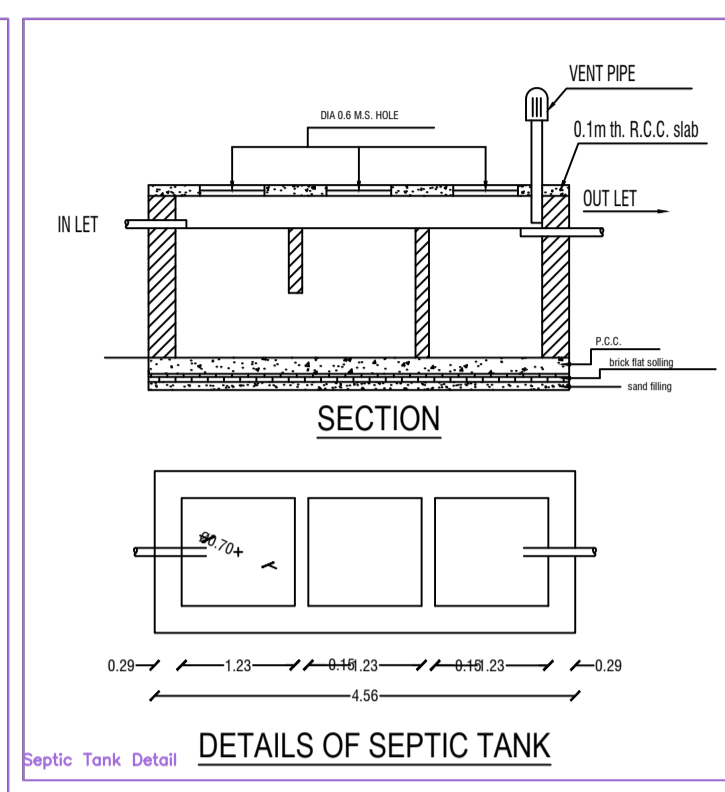
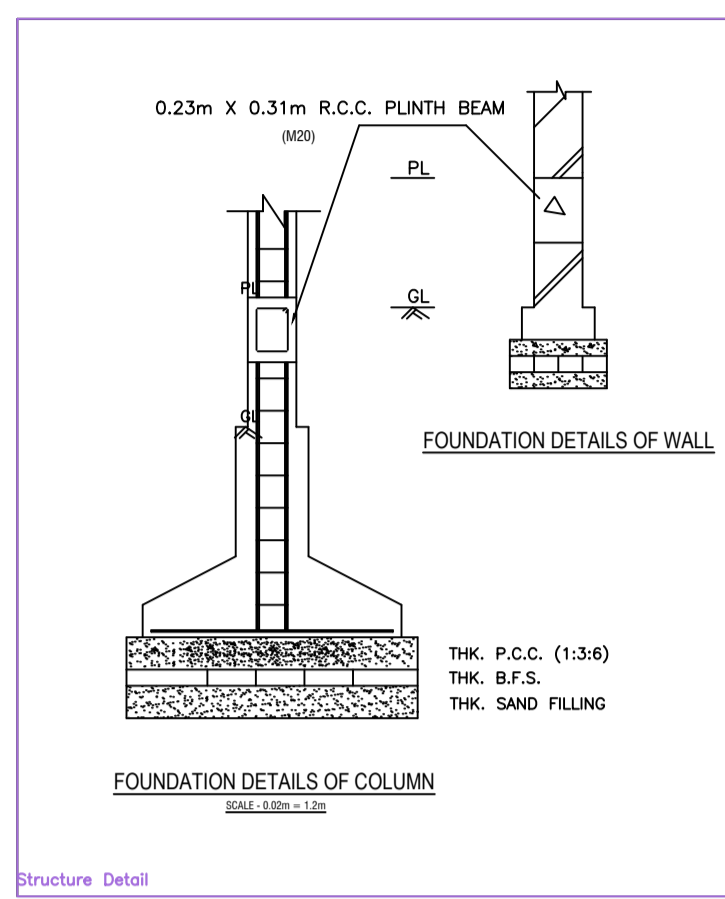

AREA STATEMENT	DHANBAD MUNICIPAL CORPORATION	VERSION NO. 1.3.36	VERSION DATE: 09/10/2020
PROJECT DETAIL			
Township No.		Plot Use - Residential	
Block No.	PANHWARD/URBAN LOCAL BODIES	Plot Sub-Use - Single/Dwelling / Non Apartment	
Location	DHANBAD	Land Use Zone - NA	
Application Type	General Proposal	Building Floor Width -	
Project Type	Building Permission	Plot No.	
Nature of Development	New	Revenue Survey No/Survey No -	
Location	Old Area	Town No -	
Sub Location	NA	Holding No -	
Wing/Block Name	-	Khata No -	
Sheet No.	-	North -	
Road/Street	-	South -	
		East -	
		West -	

AREA DETAILS		SQ.MT
Net PLOT Area (Minimum)	(A)	190.20
Net PLOT Area (Gross PLOT Area - Deduction from Gross PLOT area)	(A-Deductions)	190.20
Balance PLOT Area (Net PLOT Area - (Recreational/Security/road))	(A-Deductions)	190.20
PLOT Area for Coverage (Net PLOT Area)	(A-Deductions)	190.20
PLOT Area for PFI (Net PLOT Area - Approachways Area)	(A-Deductions)	190.20
COVERAGE CHECK		
Proposed Coverage Area (80.56 %)		111.38
Total Coverage Area (80.56 %)		111.38
FAR CHECK		
Proposed Area of FAR		222.76
Total Area of FAR		222.76
BUILD UP AREA CHECK		
Total Proposed Building Area		222.76
ARCHT ENGRG (SUPERVISOR) (Regd)		OWNER
DEVELOPMENT AUTHORITY		LOCAL BODY

BRIEF SPECIFICATION

FOUNDATION -> R.C.C. (1:1.5:3) Column footing foundation.
PLINTH -> 12"th R.C.C. (1:1.5:3) all round on plinth level.
FLOORING -> 1.5"th Marble, flooring over 3"th P.C.C. (1:1.5:3).
SUPER STRUCTURE -> First class brick work in cement mortar (1:6).
SLAB,BEAM, stairs & LINTEL -> All R.C.C. work (1:1.5:3).
WOOD WORK -> All door & window frames of sal wood
PLASTERING -> 12mm cement plaster (1:6) both side.

SCHEDULE

D1 - 1.07 X 2.13	W - 0.9 x 1.22
D2 - 0.9 X 2.13	W1 - 1.22 x 1.22
D3 - 0.76 x 2.13	W2 - 1.5 x 1.22
CG - 1.22 x 2.13	V - 0.61 x 0.61

BRIEF SPECIFICATION

FOUNDATION -> R.C.C. (1:1.5:3) Column footing foundation.
PLINTH -> 12"th R.C.C. (1:1.5:3) all round on plinth level.
FLOORING -> 1.5"th Marble, flooring over 3"th P.C.C. (1:1.5:3).
SUPER STRUCTURE -> First class brick work in cement mortar (1:6).
SLAB,BEAM, stairs & LINTEL -> All R.C.C. work (1:1.5:3).
WOOD WORK -> All door & window frames of sal wood
PLASTERING -> 12mm cement plaster (1:6) both side.

SCHEDULE

D1 - 1.07 X 2.13	W - 0.9 x 1.22
D2 - 0.9 X 2.13	W1 - 1.22 x 1.22
D3 - 0.76 x 2.13	W2 - 1.5 x 1.22
CG - 1.22 x 2.13	V - 0.61 x 0.61

SIG. OF OWNER

SIG. OF ENGINEER

Building A1 (A1)

Floor Name	Total Built Up Area (Sq.M)	Proposed FAR Area (Sq.M)	Total FAR Area (Sq.M)	Tent (No.)
Ground Floor	111.38	111.38	111.38	01
First Floor	111.38	111.38	111.38	01
Terrace Floor	0.00	0.00	0.00	01
Total	222.76	222.76	222.76	01

SCHEDULE OF JOINERY:

BUILDING NAME	NAME	LENGTH	HEIGHT	NOS
A1(A1)	D	0.76	2.10	04
A1(A1)	D	0.84	2.10	01
A1(A1)	D	0.87	2.10	01
A1(A1)	D	0.91	2.10	01
A1(A1)	D	1.07	2.10	02
Total				15

SCHEDULE OF JOINERY:

BUILDING NAME	NAME	LENGTH	HEIGHT	NOS
A1(A1)	W	0.62	1.30	01
A1(A1)	W	1.22	1.30	02
A1(A1)	W	1.40	1.30	01
A1(A1)	W	1.63	1.30	01
A1(A1)	W	1.97	1.30	01
A1(A1)	W	1.98	1.30	02
A1(A1)	W	2.00	1.30	01
A1(A1)	W	2.15	1.30	01
A1(A1)	W	2.16	1.30	01
A1(A1)	W	2.19	1.30	01
A1(A1)	W	2.27	1.30	01
A1(A1)	W	2.40	1.30	01
A1(A1)	W	2.82	1.30	01
A1(A1)	W	2.93	1.30	01
Total				18

UnitBUA Table for Building A1 (A1)

FLOOR	Name	UnitBUA Type	UnitBUA Area	Exempt Area	No. of Rooms	No. of Tenement
GROUND FLOOR	SPLIT 1	FLAT	222.77	222.55	7	1
Total			222.77	222.55	14	1