

Project Title : PRASHANT KUMAR

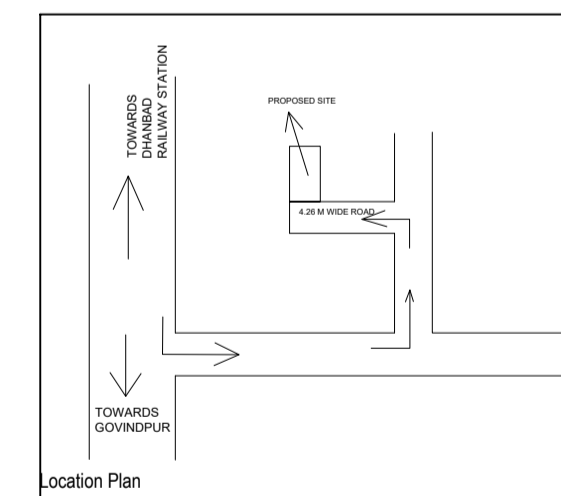
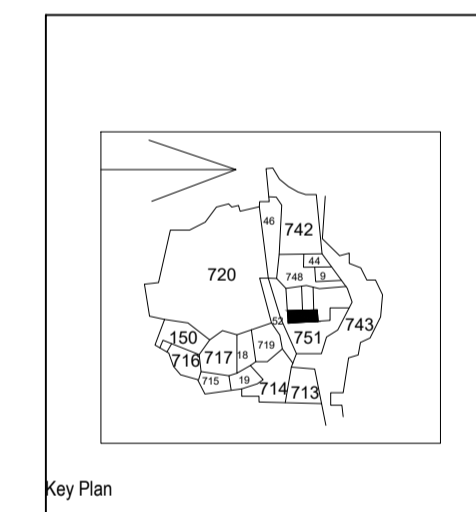
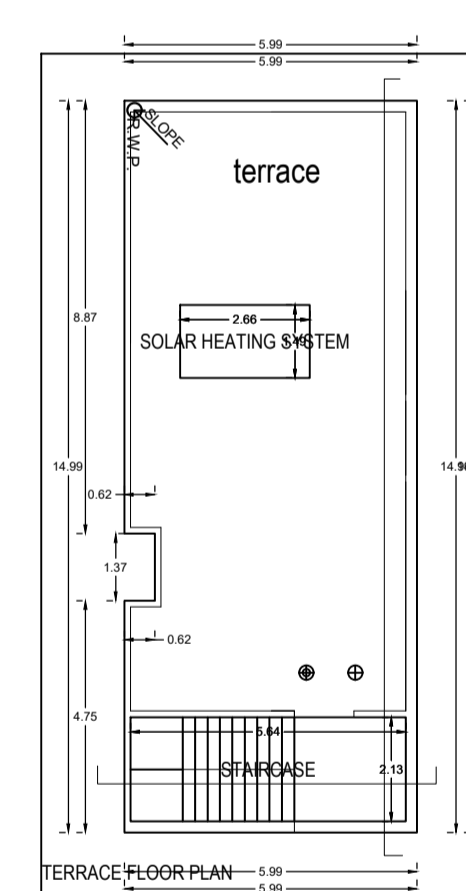
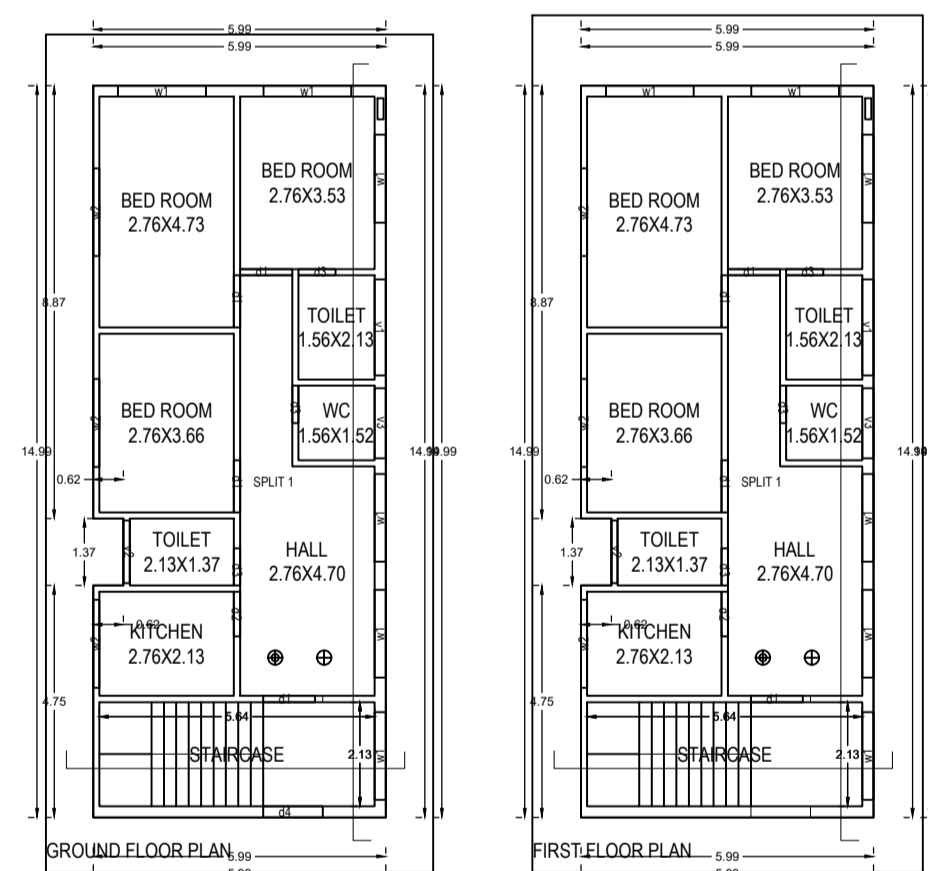
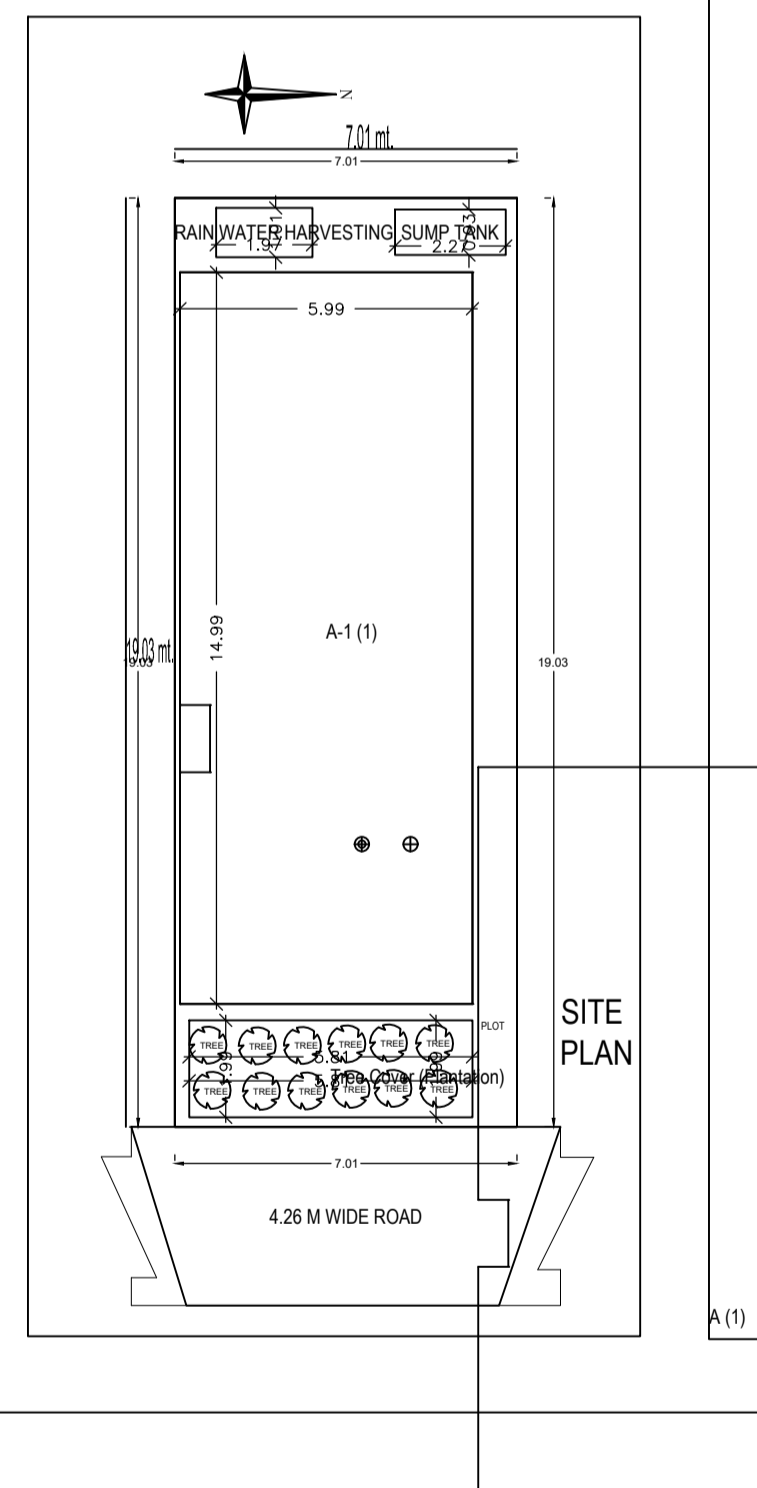
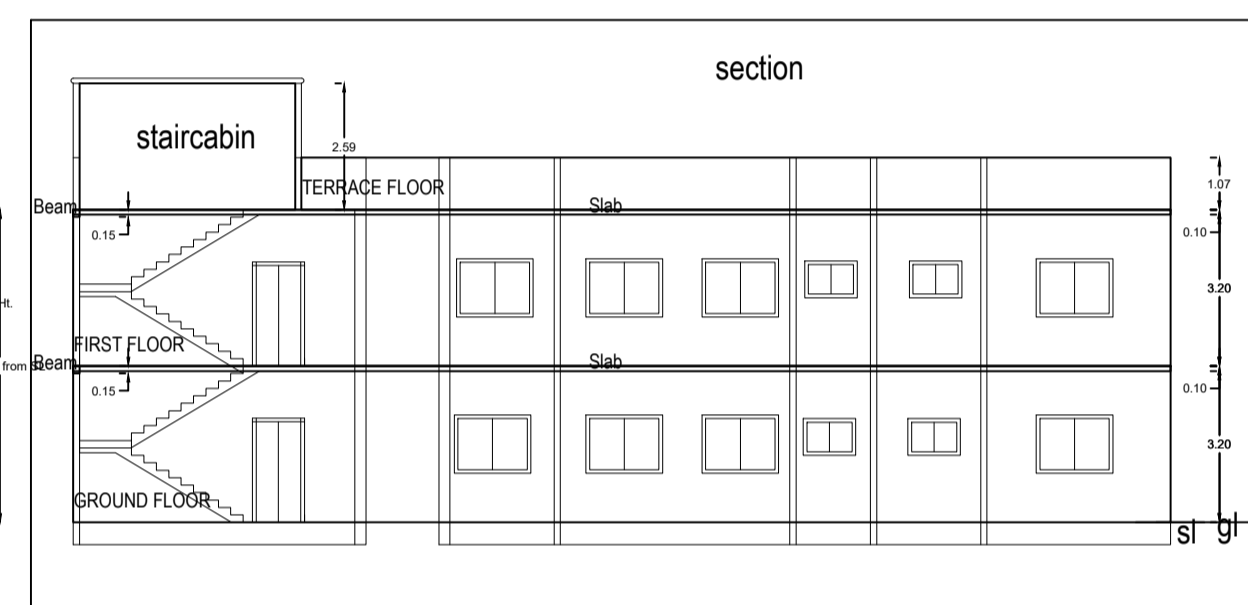
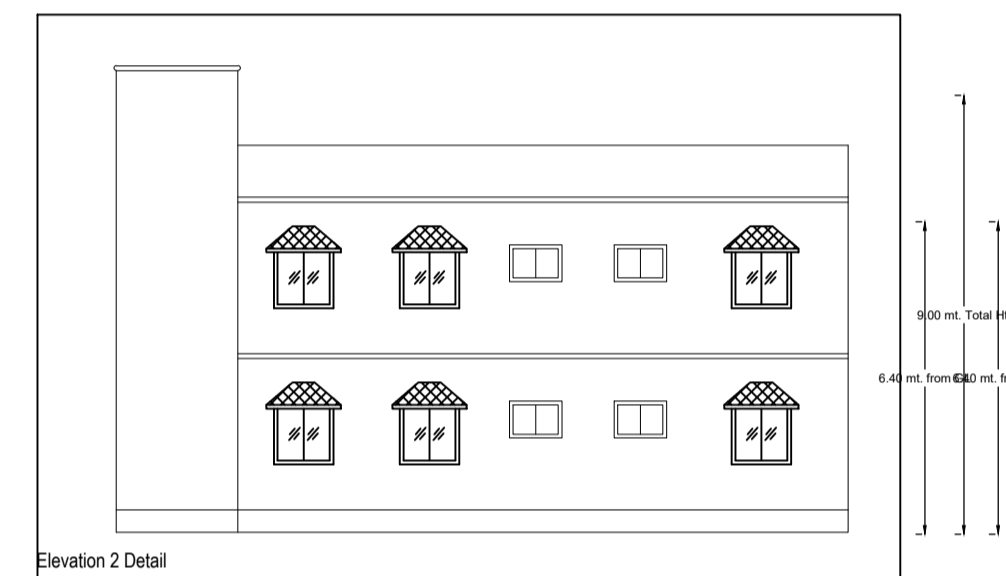
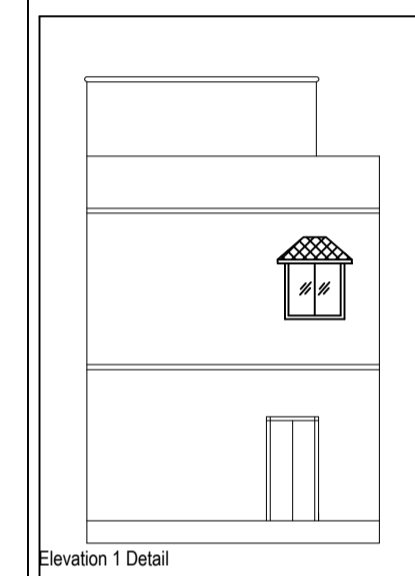
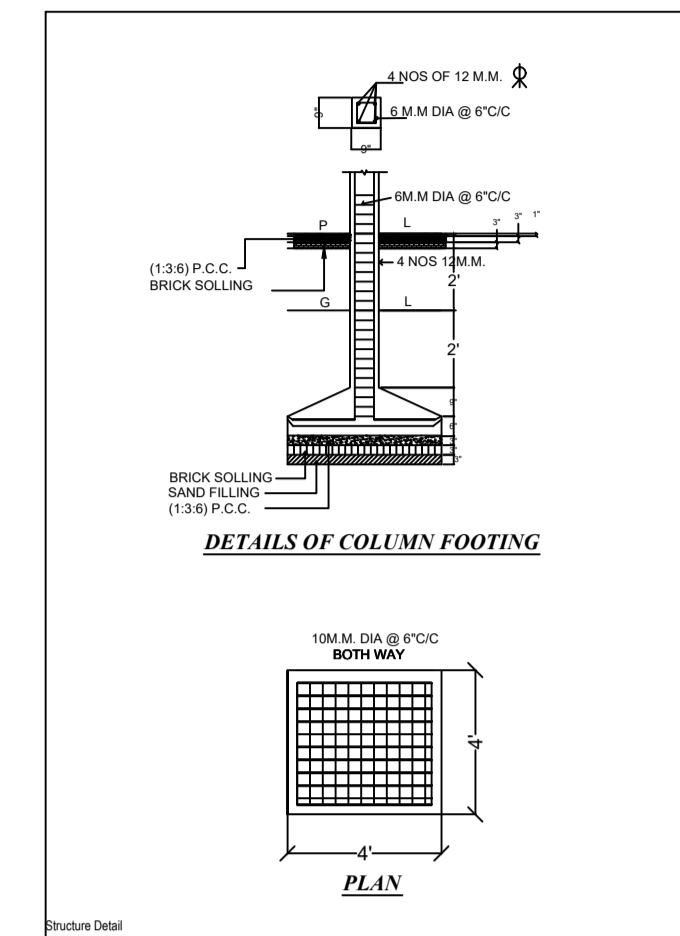
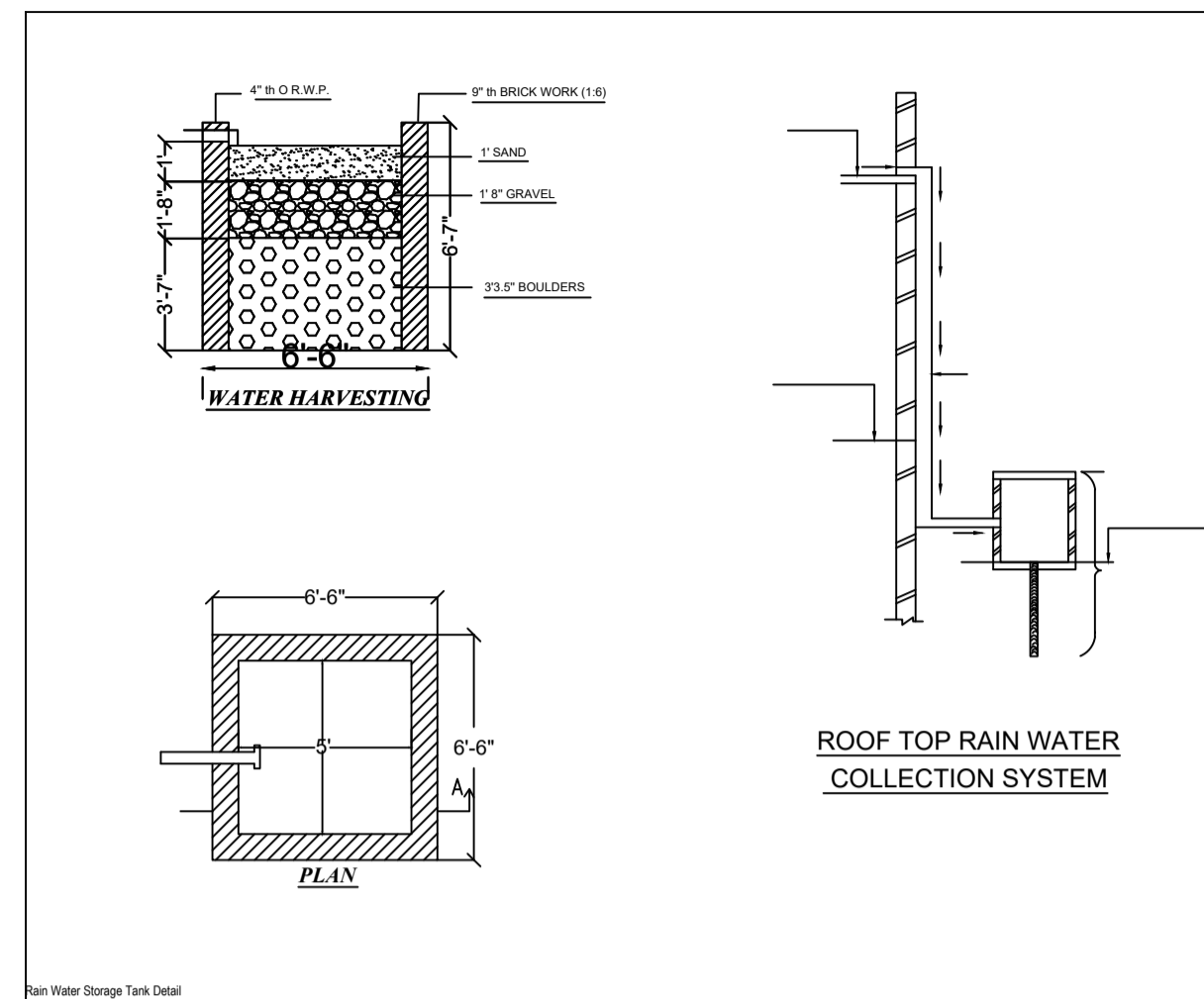
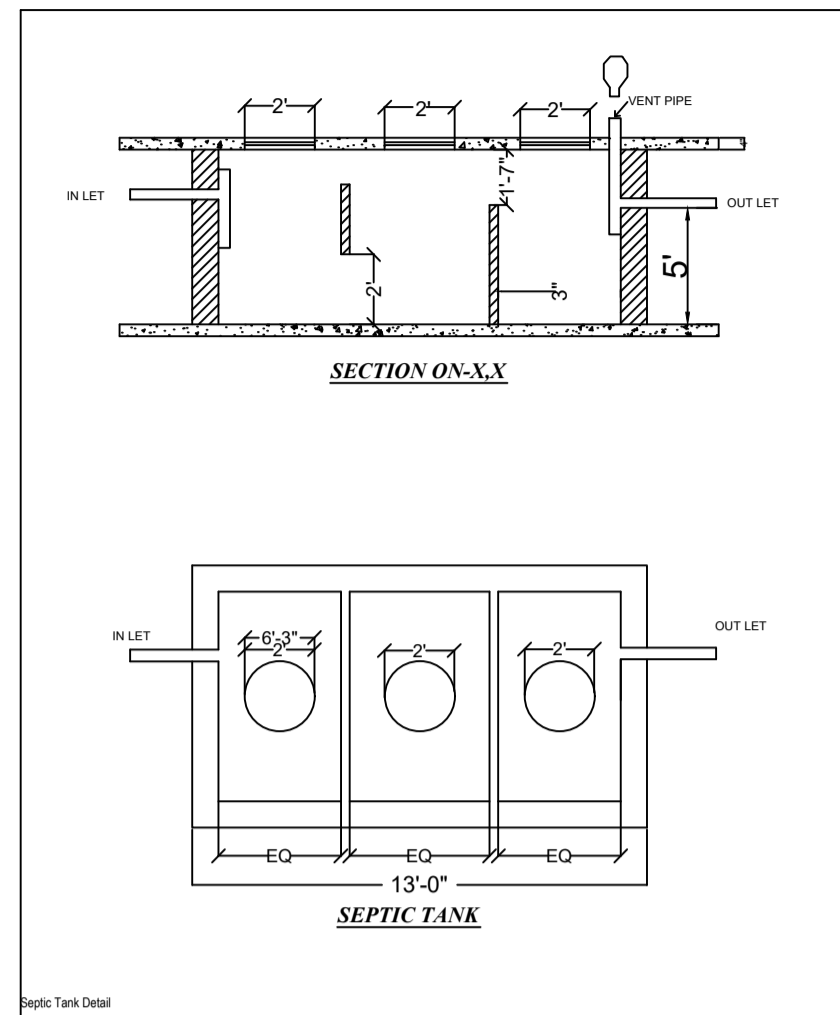

Building A (1)

Floor Name	Total Built Up Area (Sq.mt)	Proposed FAR Area (Sq.mt)	Total FAR Area (Sq.mt)	Tent (No.)
Ground Floor	89.02	89.02	89.02	01
First Floor	89.02	89.02	89.02	01
Terrace Floor	0.00	0.00	0.00	00
Total	178.04	178.04	178.04	01
Total Number of Same Buildings	1			
Total	178.04	178.04	178.04	01

SCHEDULE OF JOINERY:

ITEM/NAME	NAME	LENGTH	HEIGHT	NOS
A(1)	g3	0.78	2.10	06
A(1)	g2	0.91	2.10	02
A(1)	g1	1.07	2.10	08
A(1)	g4	1.22	2.10	01
Total	-	-	-	17

SCHEDULE OF JOINERY:

BUILDING NAME	NAME	LENGTH	HEIGHT	NOS
A(1)	v2	1.29	1.00	02
A(1)	v3	1.43	1.00	02
A(1)	w2	1.80	1.20	06
A(1)	w1	1.80	1.20	12
A(1)	v1	1.97	1.00	02
Total	-	-	-	24

UHB/UA Table for Building A (1)

FLOOR	Name	UHB/UA Type	UHB/UA Area	Carpet Area	No. of Rooms	No. of Tenement
GROUND FLOOR PLAN	SPLIT 1	FLAT	178.04	177.93	8	1
Total	-	-	178.04	177.93	8	1

AREA STATEMENT: DHANBAD MUNICIPAL CORPORATION		VERSION NO. : 1.0.36
PROJECT DETAIL:		VERSION DATE: 16/10/2020
Tward No.	Plot Use: Residential	
Map No. (PASHWARI URBAN LOCAL BODIES)	Plot Sub Use: Residential/Commercial/Non Apartment	
District: DHANBAD	Land Use Zone: Residential	
Application Type: General Proposal	Abutting Road Width: -	
Project Type: Building Permission	Plot No. -	
Nature of Development: New	Revenue Survey No/Survey No. -	
Location: Old Area	Thana No. -	
Sub Location: N/A	HOISING No. -	
Village/Moosa Name -	Khata No. -	
Plot No. -	South -	
Road/Street -	East -	
	West -	
AREA DETAILS:		SQ.MT
AREA OF PLOT (Minimum)	(A)	133.49
NET PLOT AREA (Gross Plot Area - Deduction from Gross Plot area)	(A Deductions)	133.49
Deductions for Balance Plot Area (from Gross Plot Area)		11.96
COF Area		11.96
Total		11.96
Balance Plot Area (Net Plot Area - Recreational/Amenity space)	(A Deductions)	121.92
Plot Area for Coverage (Net Plot Area)	(A Deductions)	133.49
Plot Area for FSI (Net Plot Area - Road/Watering Area)	(A Deductions)	133.49
COVERAGE CHECK		
Proposed Coverage Area (60.00%)		89.02
Total Coverage Area (60.00%)		89.02
FAR CHECK		
Proposed Area of FAR		178.04
Total Area of FAR		178.04
BUILT UP AREA CHECK		
Total Proposed Built Up Area		178.04
ARCHT/ENGR/ SUPERVISOR (Sign)	OWNER	
DEVELOPMENT AUTHORITY		LOCAL BODY

COLOR INDEX

PLOT BOUNDARY
 ABUTTING ROAD
 PROPOSED WORK (COVERAGE AREA)
 EXISTING (To be retained)
 EXISTING (To be demolished)

MARGIN DETAIL:

Building / Wdg	Road Name	Front Margin	Rear Margin	Side Margin	Sidc Margin
A(1)	4.26 M WIDE ROAD	3.32	1.02	0.10	0.91

FAR & Tenement Details (Table 4c-1)

Building	No. of Same Bldg	Total Built Up Area (Sq.mt)	Proposed FAR Area (Sq.mt)	Total FAR Area (Sq.mt)	Tent (No.)
A(1)	1	178.04	178.04	178.04	01
Grand Total	1	178.04	178.04	178.04	01