

Project Title :MUSARRAT ZAID

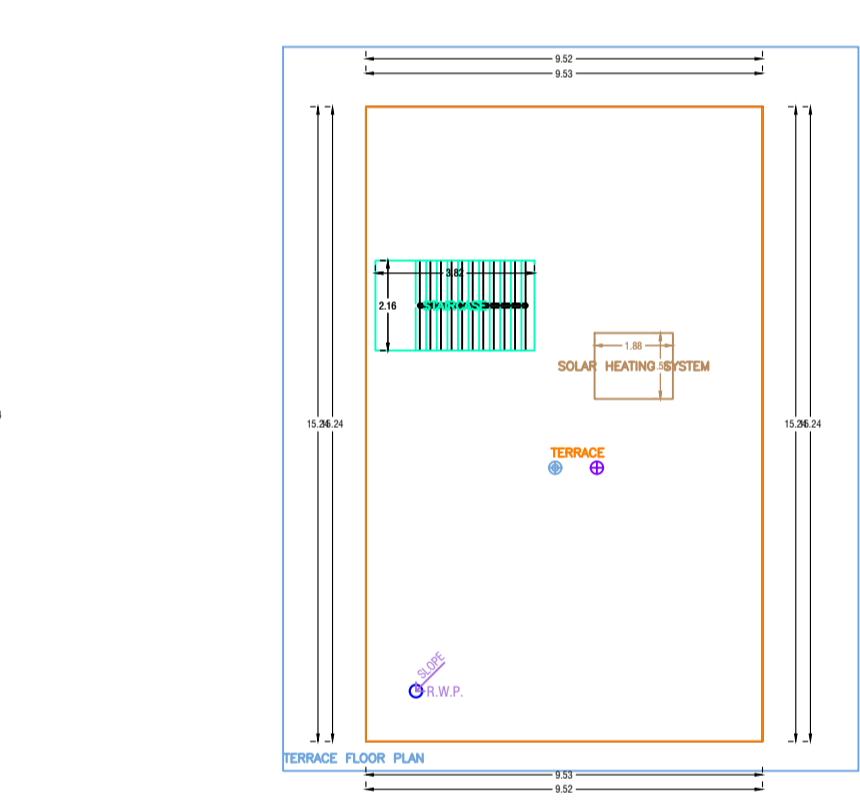
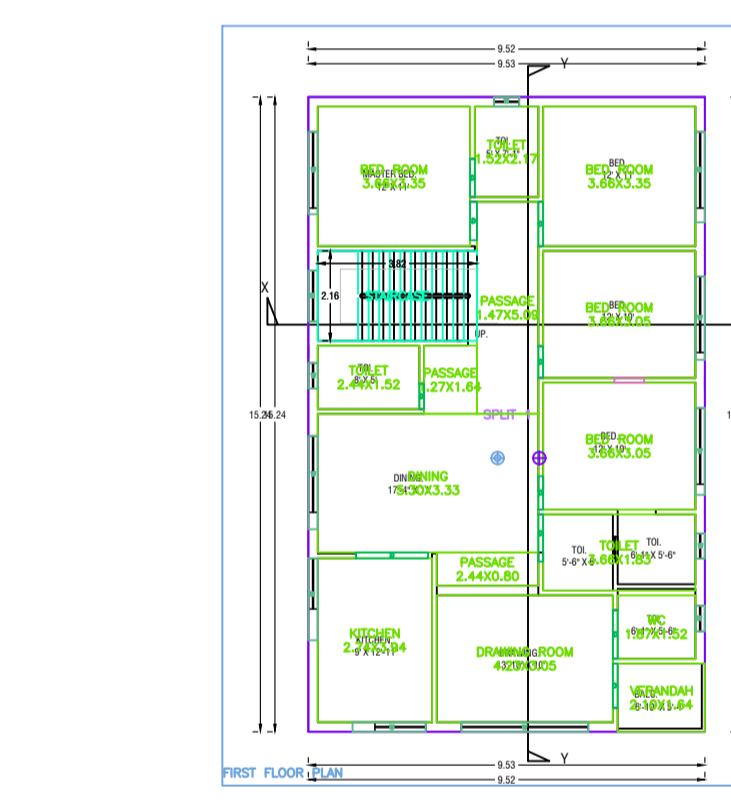
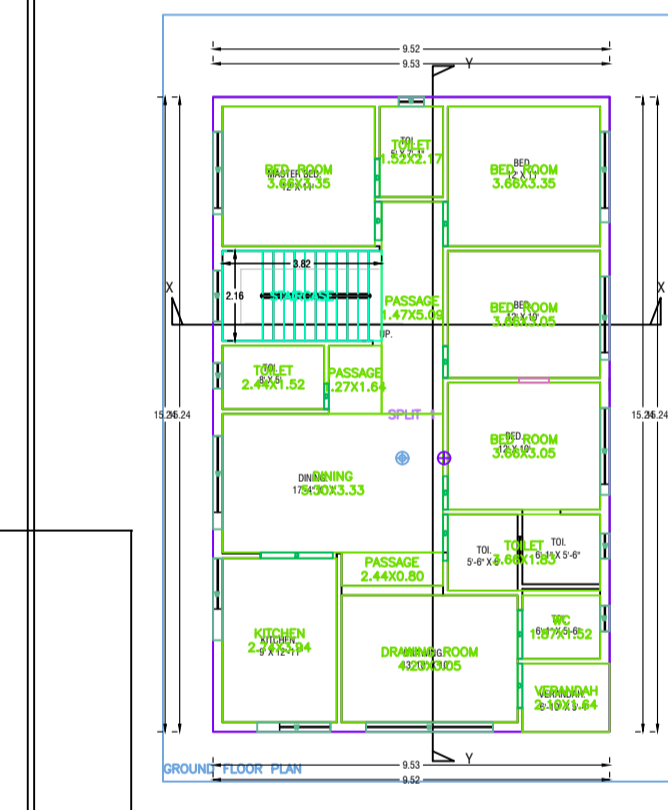
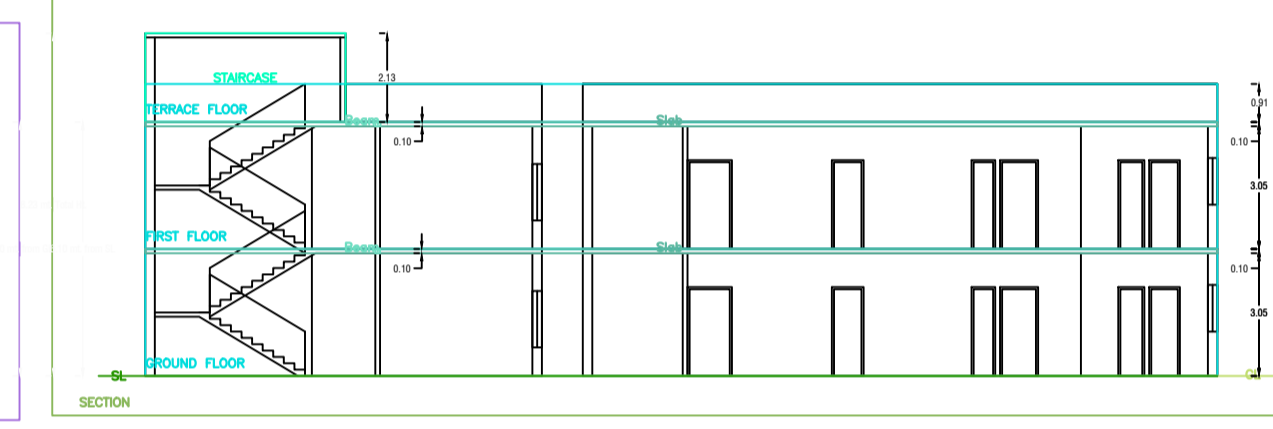
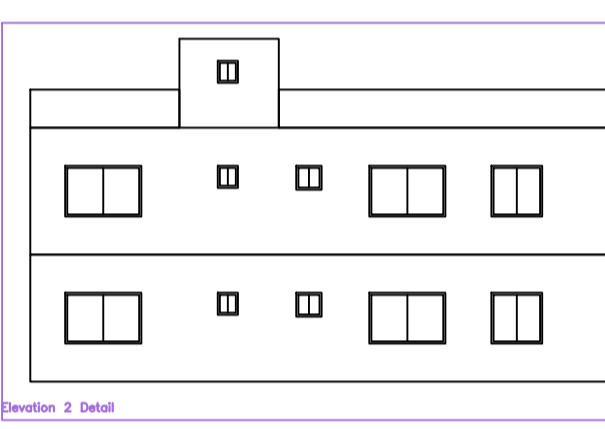
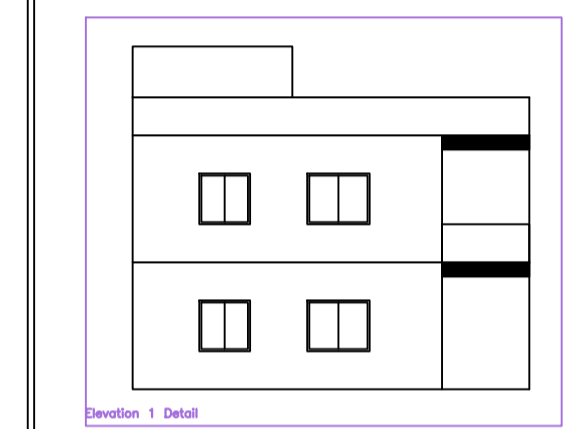
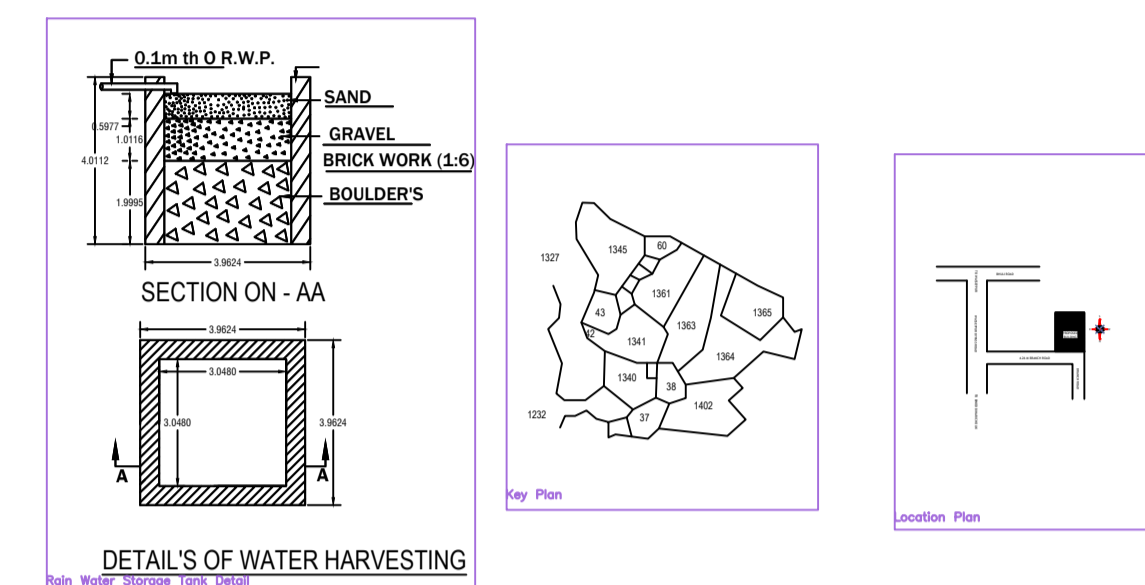
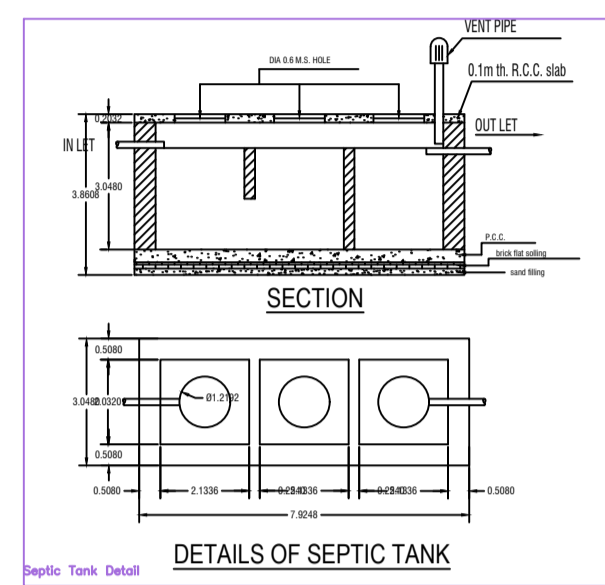
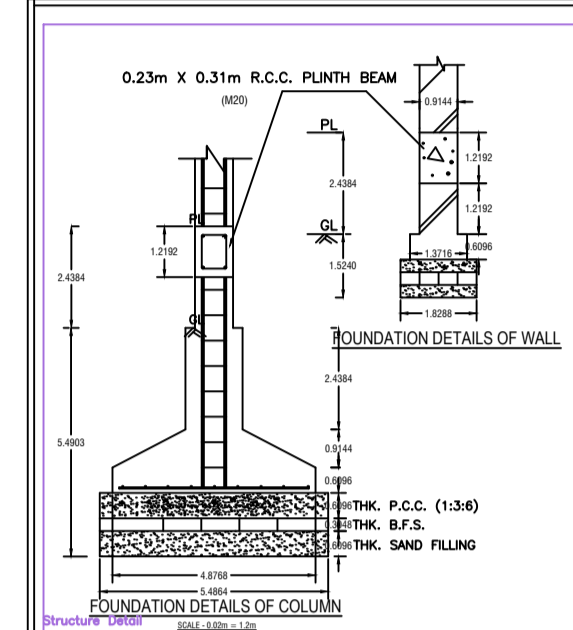
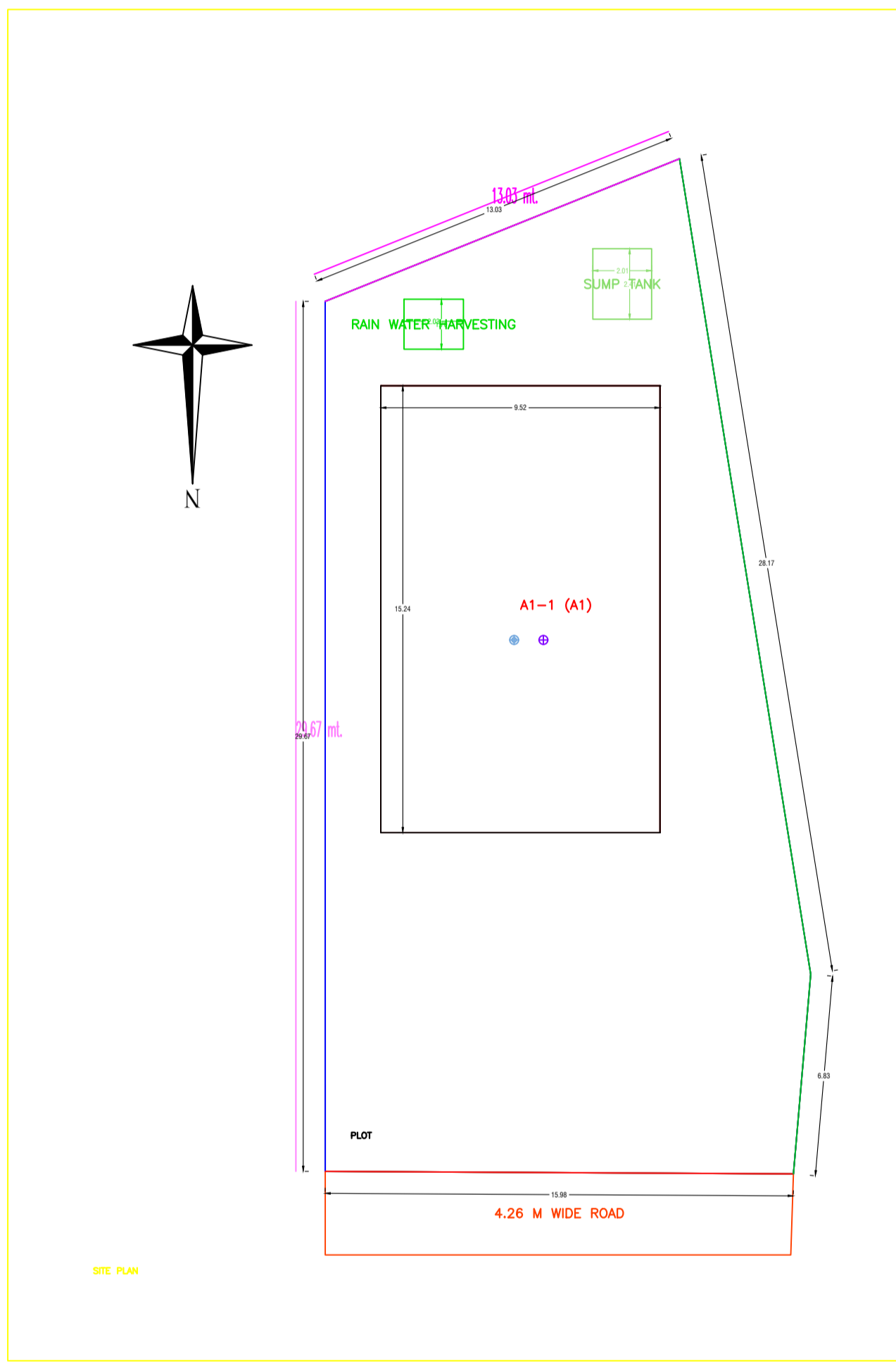

BRIEF SPECIFICATION

FOUNDATION - R.C.C. (1:1.5:3) Column footing foundation.
PLINTH - 12"th R.C.C. (1:1.5:3) all round on plinth level.
FLOORING - 1.5"th Marble flooring over 3"th P.C.C. (1:3:6).
SUPER STRUCTURE - First class brick work in cement mortar (1:5:6).
SLAB, BEAM, STAIRS & LINTEL - All R.C.C. work (1:1.5:3).
WOOD WORK - All door & window frames of sal wood.
PLASTERING - 12mm cement plaster (1:5) both side.

SCHEDULE

D1 - 1.07 x 2.13	W - 0.9 x 1.22
D2 - 0.9 x 2.13	W1 - 1.22 x 1.22
D3 - 0.76 x 2.13	W2 - 1.5 x 1.22
CG - 1.22 x 2.13	V - 0.61 x 0.61

SIG. OF OWNER

SIG. OF ENGINEER

Building A1 (A1)

FLOOR NAME	Total Built Up Area (Sq.m)	Proposed FAR Area (Sq.m)	Total FAR Area (Sq.m)	Floor No.
Ground Floor	145.16	145.16	145.16	01
First Floor	145.16	145.16	145.16	02
Terrace Floor	200.32	200.32	200.32	03
Total	290.32	290.32	290.32	01
Total Number of Same Buildings	1			
Total	290.32	290.32	290.32	01

SCHEDULE OF JOINERY:

ITEM	NAME	LENGTH	HEIGHT	NO.
PTX01	D	0.91	2.13	02
PTX02	D	0.76	2.13	02
PTX03	D	0.91	2.13	02
PTX04	D	0.91	2.13	02
PTX05	D	0.91	2.13	02
PTX06	D	1.07	2.13	04
PTX07	D	1.11	2.13	02
PTX08	D	1.13	2.13	01
PTX09	D	1.17	2.13	02
PTX10	D	1.23	2.13	02
Total				29

SCHEDULE OF JOINERY:

BUILDING NAME	NAME	LENGTH	HEIGHT	NO.
PTX01	W	0.91	1.20	08
PTX02	W	0.76	1.20	02
PTX03	W	1.76	1.20	02
PTX04	W	1.33	1.20	02
PTX05	W	1.58	1.20	02
PTX06	W	2.00	1.20	02
PTX07	W	2.09	1.20	02
PTX08	W	2.17	1.20	02
PTX09	W	2.14	1.20	02
PTX10	W	3.05	1.20	02
Total				39

UseBUA Table for Building A1 (A1)

FLOOR	Name	USEBUA Type	USEBUA Area	Carpet Area	No. of Rooms	No. of Tenements
GROUND FLOOR	SPLIT 1	FLAT	290.32	290.16	15	1
Total			290.32	290.16	15	1

AREA STATEMENT (SHARAD MUNICIPAL CORPORATION) VERSION NO. 1.0.38

PROJECT DETAIL	VERSION DATE: 04/05/2020
Project No.	Plot No. 145/2020
Region - SHARAD URBAN LOCAL BODIES	Plot Category - Single/Double/Non Apartment
Client - SHARAD	Plot Category - Single/Double/Non Apartment
Application Type - General Proposal	Land Use Zone - NA
Project Type - Building Permission	Plot No. -
Number of allotment - None	Plot Area (sq.m)
Location - Old Area	Thana No. -
Plot Number - NA	Ward No. -
Village/Mazra Name -	Khasra No. -
Plot No. -	Soan -
Block/Zone -	East -
Sheet -	West -

AREA DETAILS:

AREA OF FOOT (sq.m)	IN	sq.m	sq.ft
Net FAR Area (Gross FAR Area)	(A) Deductions	479.00	479.00
Net FAR Area (Net FAR Area)	(A) Deductions	479.00	479.00
Balance FAR Area (Net FAR Area)	(A) Deductions	479.00	479.00
FAR Area for Coverage (Net FAR Area)	(A) Deductions	479.00	479.00
FAR Area for FAR (Net FAR Area)	(A) Deductions	479.00	479.00
Proposed Coverage Area (30.30%)		145.16	145.16
Total Coverage Area (30.30%)		145.16	145.16
REMARKS			
Proposed Area of FAR		290.32	290.32
Total Area of FAR		290.32	290.32
BUILT UP AREA CHECK			
Total Proposed Built Up Area		290.32	290.32
PERCENT ERROR (Tolerant Range)			
DEVELOPMENT AUTHORITY		LOCAL BODY	

COLOR INDEX

Color Index:

Color	Meaning
Red	Plot Boundary
Blue	Plot Boundary
Green	Proposed Work (Coverage Area)
Black	Existing (To be retained)
Yellow	Existing (To be demolished)

MARGIN DETAIL:

Building / Plot	Road Name	Front Margin	Rear Margin	Side Margin	Setback Margin
A1/A1	2.00 M WIDE ROAD	11.56	3.18	1.50	1.83

FAR & Tenement Details (Table 4c-1)

Building	No. of Same Bldg	Total Built Up Area (sq.m)	Proposed FAR Area (sq.m)	Total FAR Area	Floor No.
A1/A1	1	290.32	290.32	290.32	01
Grand Total	1	290.32	290.32	290.32	01