

Proposal Basic Information

Proposal File No.	DMC/BP/0178/W23/2023
Owner Name	(1) SRI PAWAN KUMAR AGARWAL (2) SRI SANTOSH KUMAR AGARWAL (3) SRI SANJAY KUMAR AGARWAL
Khata No	NEW -731, OLD- 68
Plot No	NEW -286&287, OLD -188&343
Village Name	Kolakusma
Use	Residential
SubUse	Bungalow/ Dwelling / Non Apartment

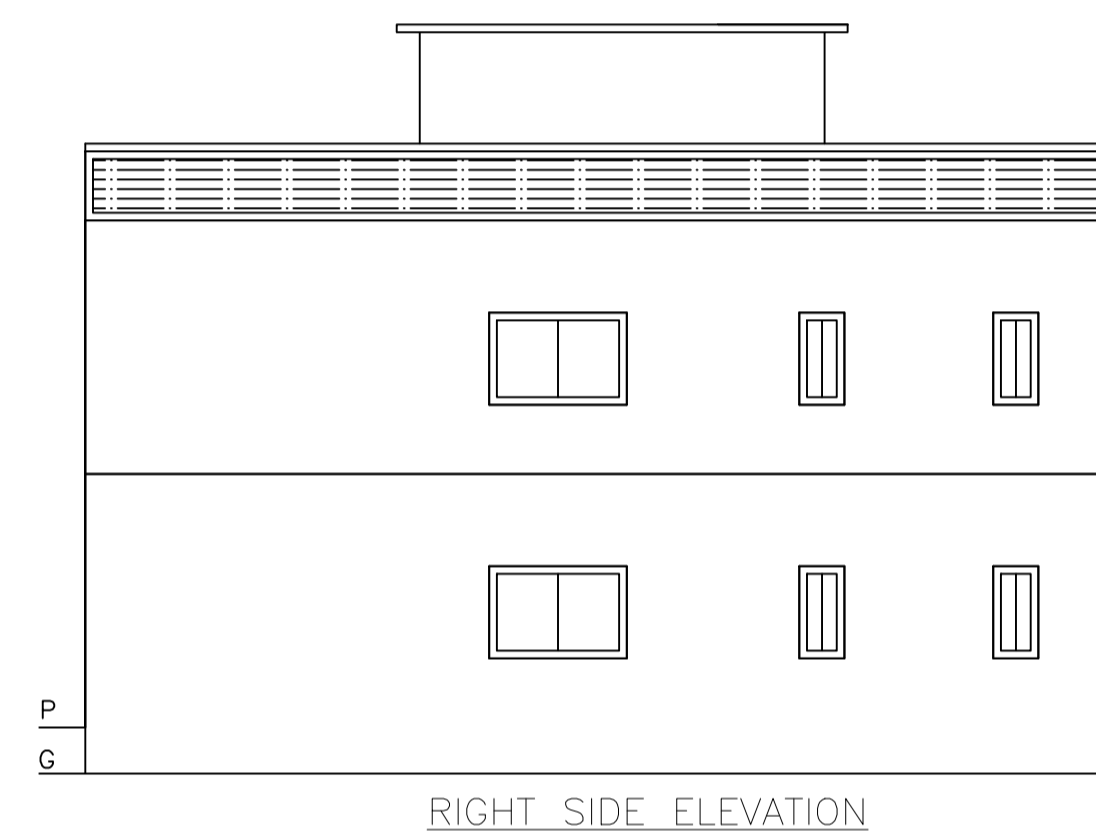
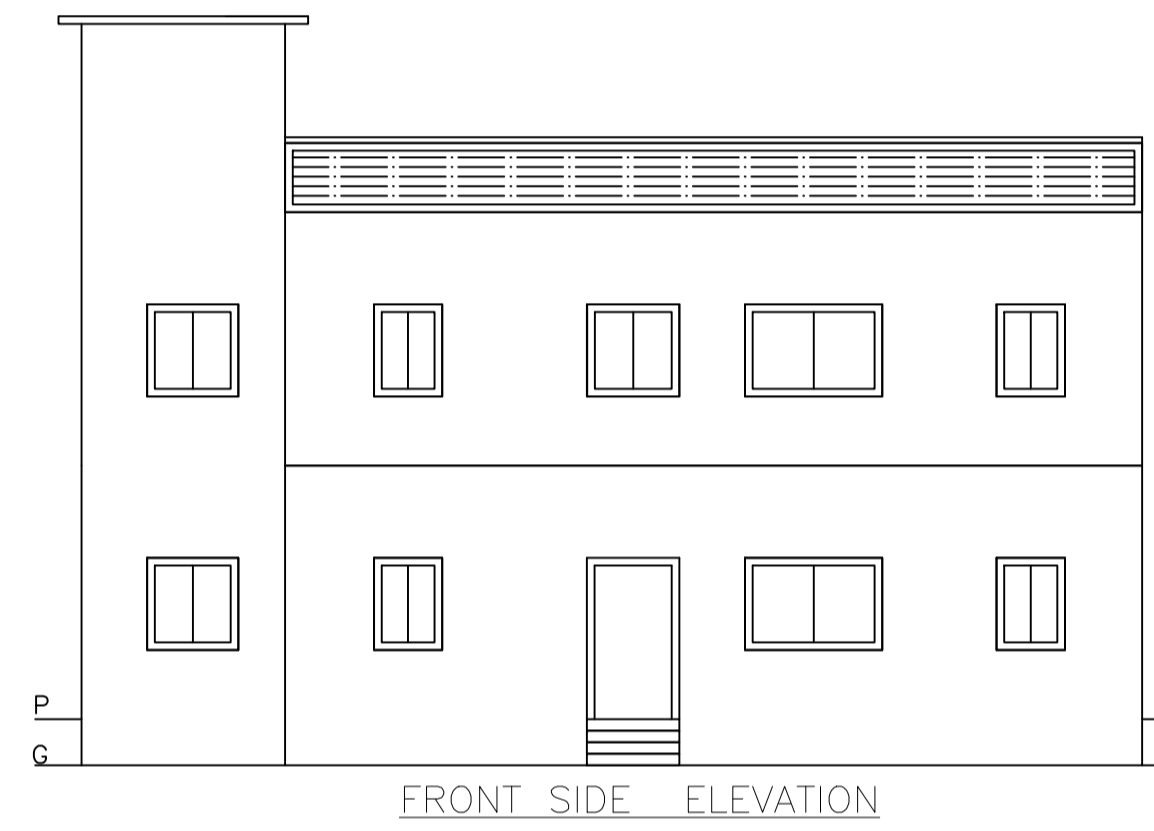
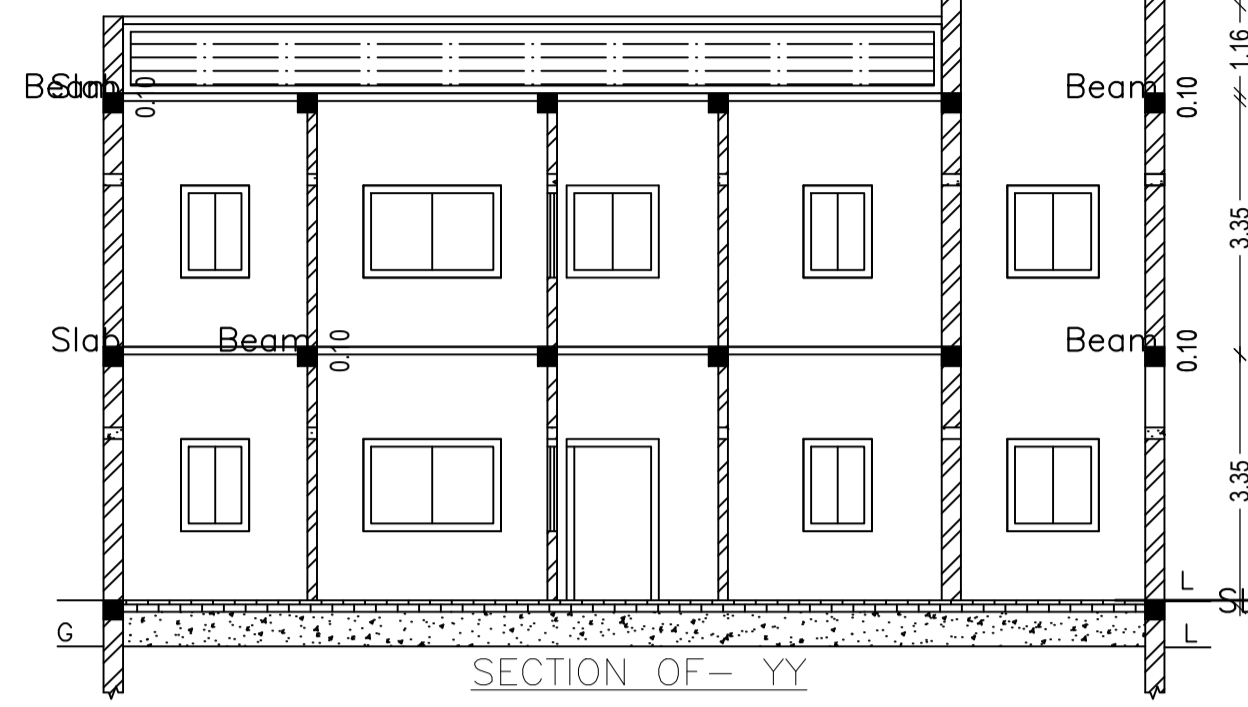
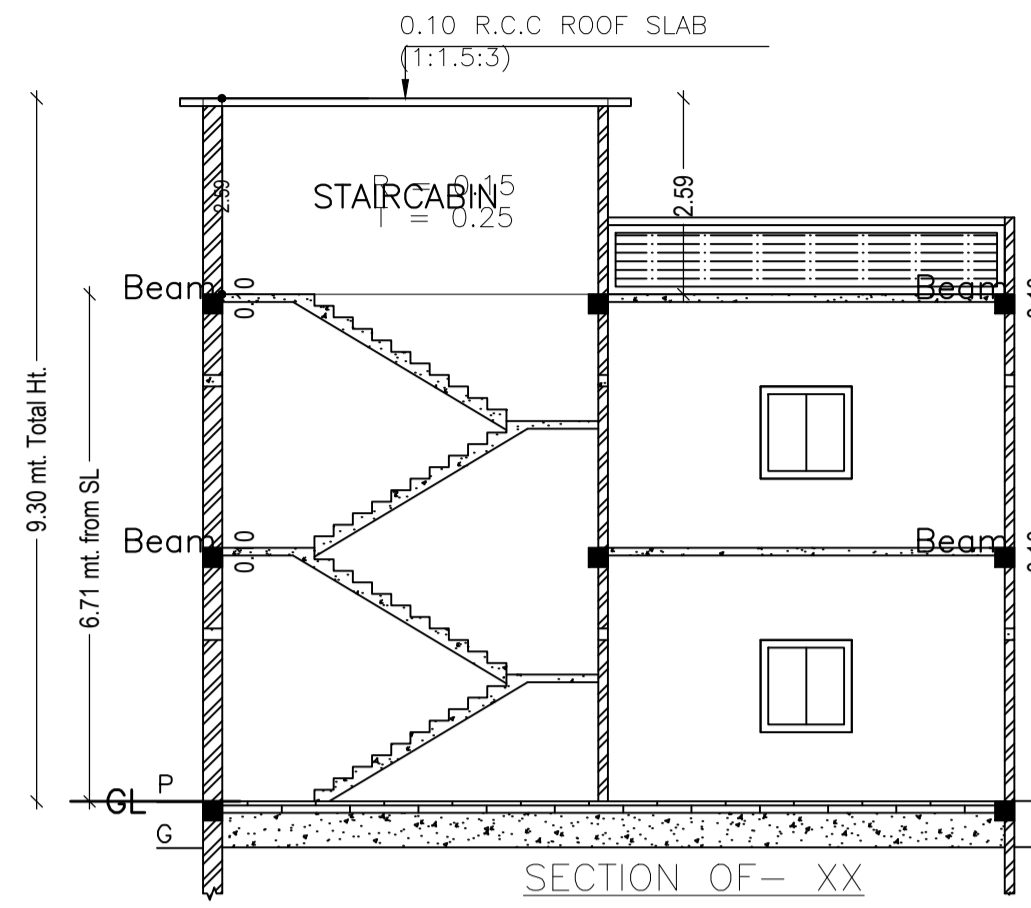
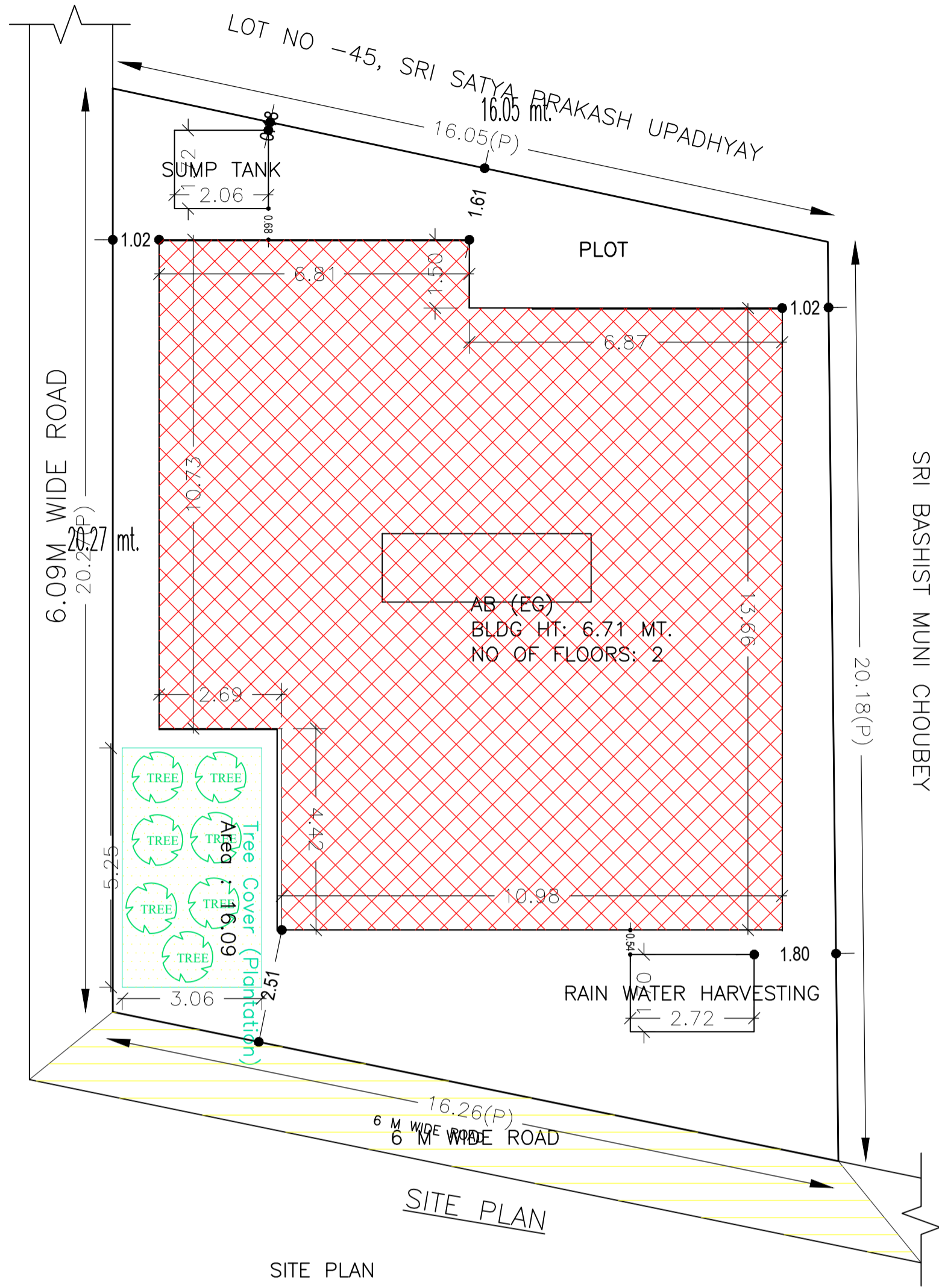
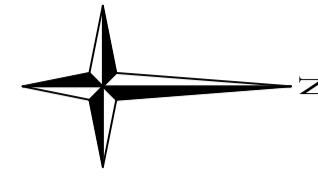

AREA STATEMENT	VERSION NO.: 1.0.66
DHANBAD MUNICIPAL CORPORATION	VERSION DATE: 16/10/2020
PROJECT DETAIL:	
Region: JHARKHAND URBAN LOCAL BODIES	Plot Use: Residential
District: DHANBAD	Plot SubUse: Bungalow/ Dwelling / Non Apartment
Authority: DHANBAD MUNICIPAL CORPORATION	Plot/Nearby/ReligiousStructure: NA
Inward No: DMC/BP/0178/W23/2023	Plot/SubPlot No: NEW -286&287, OLD -188&343
Application Type: General Proposal	North: Road Width - 6.09M WIDE ROAD
Project Type: Building Permission	South: Plot No. - SRI BASHIST MUNI CHOUBEY
Nature of Development: New	East: Road Width - 6.09M WIDE ROAD
Location of Development Area: Old Area	West: Plot No. - LOT NO -45, SRI SATYA PRAKASH UPADHYAY
AREA DETAILS:	
AREA OF PLOT (Minimum)	(A) 319.39 SQ.MT.
NET AREA OF PLOT (Gross Plot Area - Deduction from Gross Plot area)	(A-Deductions) 319.39
Deduction for Balance Plot Area (from Gross Plot Area)	
Common Plot	16.09
Total	16.09
BALANCE AREA OF PLOT (Net Plot Area - Recreational/Amenity space)	(A-Deductions) 303.30
PLOT AREA FOR COVERAGE (Net Plot Area)	(A-Deductions) 319.39
Plot Area for FAR (Net Plot Area + Road Widening Area)	(A-Deductions) 319.39
COVERAGE CHECK	
Permissible Coverage area (60.00 %)	191.63
Proposed Coverage Area (57.94 %)	185.04
Total Prop. Coverage Area (57.94 %)	185.04
Balance coverage area (2.06 %)	6.59
FAR CHECK	
Perm. FAR Area (1.800)	574.90
Total Perm. FAR area	574.90
Residential FAR	370.54
Proposed FAR Area	370.54
Total Proposed FAR Area	370.54
Consumed FAR (Factor)	1.16
Balance FAR Area	204.36
BUILT UP AREA CHECK	
Total Proposed BuiltUp Area	370.53
ARCHITECT (Regd)	Kushjee Pandey
ENGINEER (Regd)	
SUPERVISOR (Regd)	
OWNER (Regd)	(1) SRI PAWAN KUMAR AGARWAL (2) SRI SANTOSH KUMAR AGARWAL (3) SRI SANJAY KUMAR AGARWAL
DEVELOPMENT AUTHORITY	LOCAL BODY

SITE PLAN

SCHEDULE OF DOOR:

BUILDING NAME	NAME	LENGTH	HEIGHT	NOS
AB (EG)	D	0.76	2.10	06
AB (EG)	D	0.91	2.10	02
AB (EG)	D	1.07	2.10	07
AB (EG)	D	1.17	2.10	01
AB (EG)	D	1.21	2.10	02
AB (EG)	D	1.22	2.10	03
AB (EG)	D	1.47	2.10	02

SCHEDULE OF WINDOW/VENTILATION:

BUILDING NAME	NAME	LENGTH	HEIGHT	NOS
AB (EG)	W	0.60	1.20	04
AB (EG)	W	0.61	1.20	02
AB (EG)	W	0.82	1.20	02
AB (EG)	W	0.90	1.20	02
AB (EG)	W	1.21	1.20	03
AB (EG)	W	1.22	1.20	04
AB (EG)	W2	1.49	2.00	02
AB (EG)	W	1.82	1.20	04

UnitBUA Table for Building :AB (EG)

FLOOR	Name	UnitBUA Type	UnitBUA Area	Carpent Area	No. of Rooms	No. of Tenement
GROUND FLOOR PLAN	SPLIT ABC	FLAT	370.54	370.44	11	1
FIRST FLOOR PLAN	SPLIT ABC	FLAT	0.00	0.00	11	0
Total:			370.54	370.44	22	1

FAR & Tenement Details (Table 4c-1)

Building	No. of Same Bldg	Total Built Up Area (Sq.mt.)	Proposed FAR Area (Sq.mt.) Resi.	Total FAR Area (Sq.mt.)	Total Consumed Additional FAR Area (Sq.mt.)	Tnmt (No.)
AB (EG)	1	370.53	370.53	370.53	370.53	01
Grand Total:	1	370.53	370.53	370.53	370.53	01

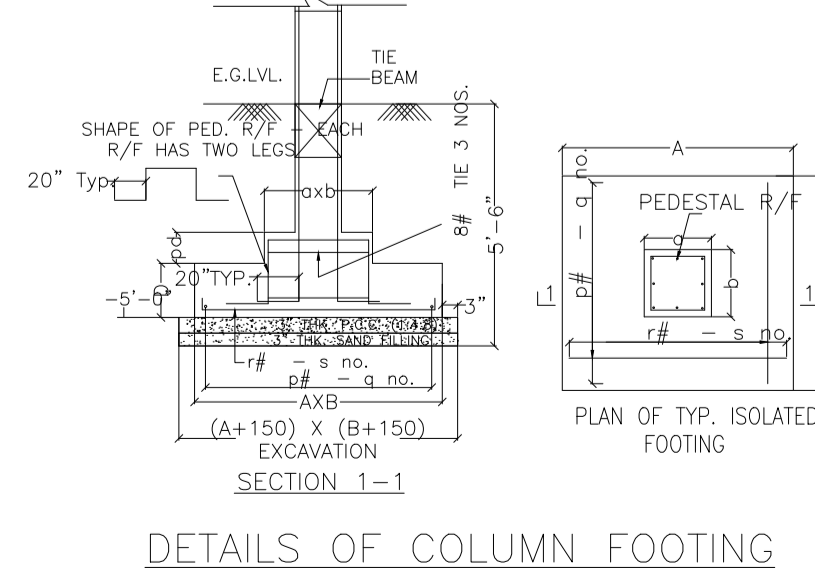
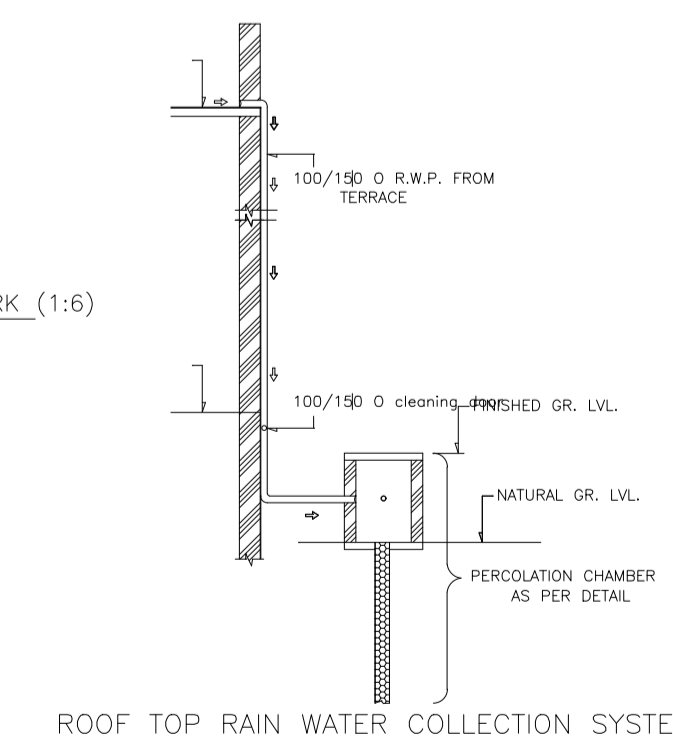
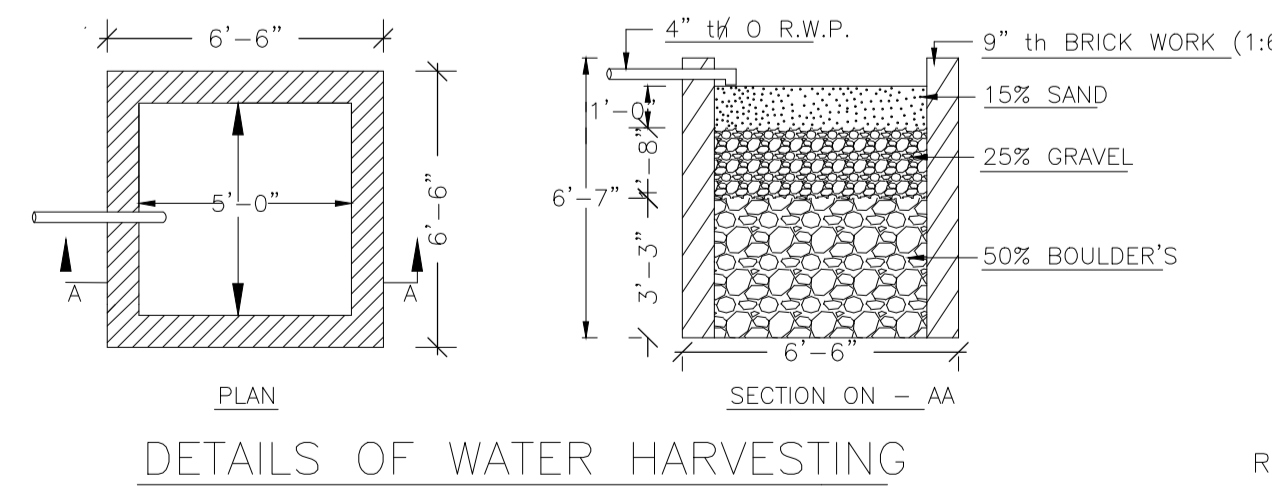
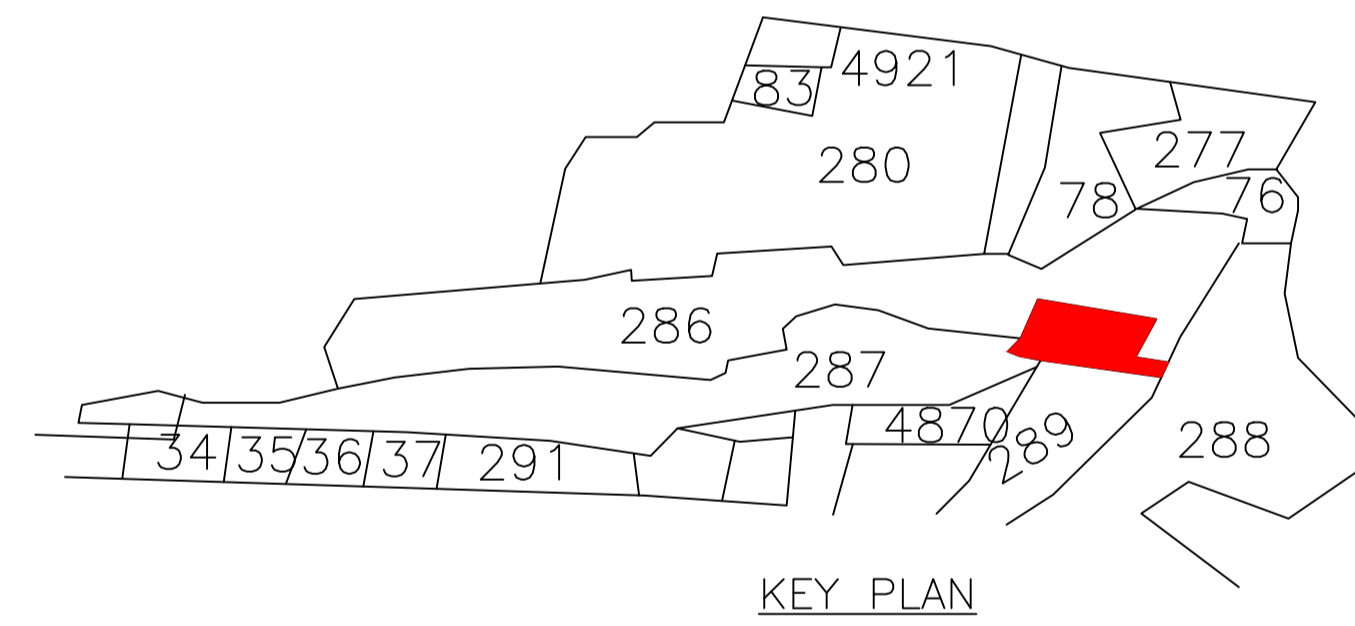
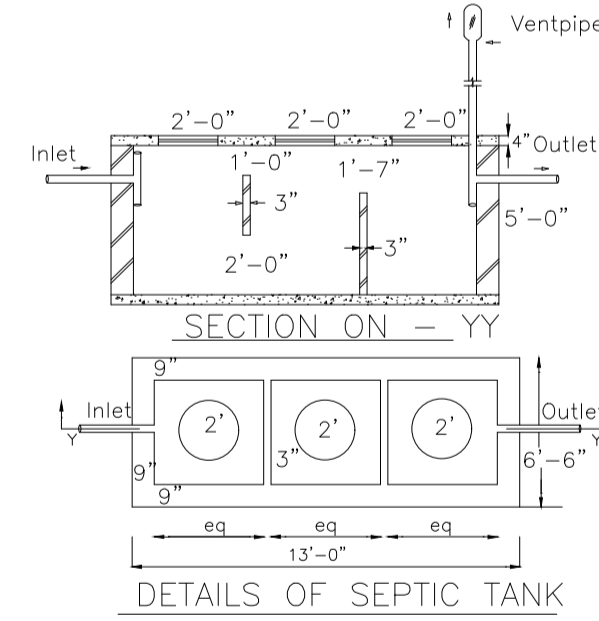
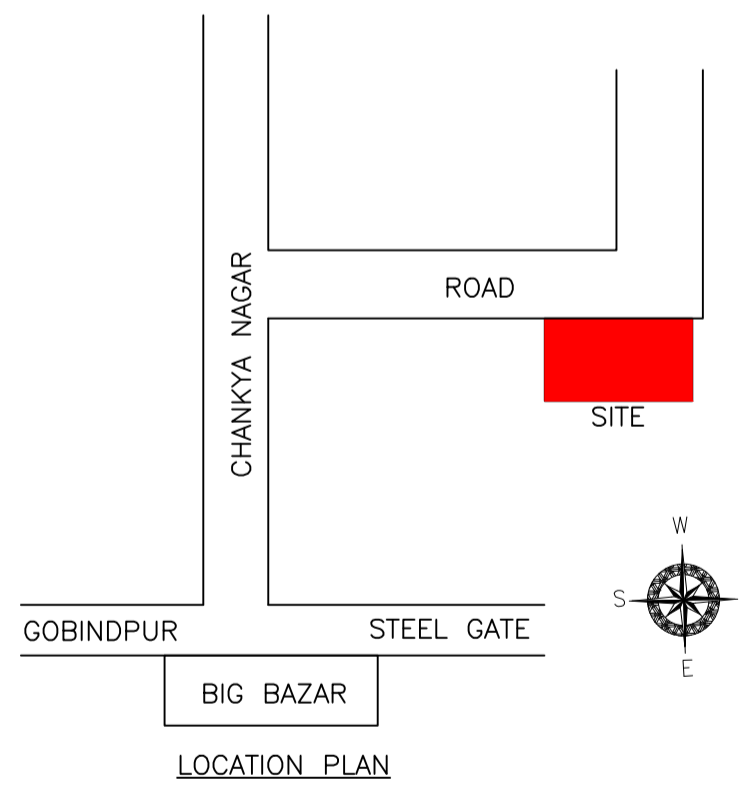

COLOR INDEX	
PLOT BOUNDARY	Black
ABUTTING ROAD	Green
PROPOSED CONSTRUCTION	Red
COMMON PLOT	Yellow
ROAD WIDENING AREA	Blue
EXISTING (To be retained)	Light Blue
EXISTING (To be demolished)	Light Yellow

Buildingwise Floor FAR Details

Floor Name	Building Name		Total	
	Proposed Built Up Area (Sq.mt.)	Proposed FAR Area (Sq.mt.)	Total Proposed Built Up Area (Sq.mt.)	Total FAR Area (Sq.mt.)
Ground Floor	185.04	185.04	185.04	185.04
First Floor	185.49	185.49	185.49	185.49
Terrace Floor	0.00	0.00	0.00	0.00
Total:	370.53	370.53	370.53	370.53

Building USE/SUBUSE Details

Building Name	Building Use	Building SubUse	Building Structure
AB (EG)	Residential	Bungalow/ Dwelling / Non Apartment	Non-Highrise

Building :AB (EG)

Floor Name	Total Built Up Area (Sq.mt.)	Proposed FAR Area (Sq.mt.) Resi.	Total FAR Area (Sq.mt.)	Total Consumed Additional FAR Area (Sq.mt.)	Tnmt (No.)
Ground Floor	185.04	185.04	185.04	185.04	01
First Floor	185.49	185.49	185.49	185.49	00
Terrace Floor	0.00	0.00	0.00	0.00	00
Total:	370.53	370.53	370.53	370.53	01
Total Number of Same Buildings :	1				
Total:	370.53	370.53	370.53	370.53	01

LTP NAME AND SIGNATURE	STRUCTURAL ENG'S NAME AND SIGNATURE	BUILDER NAME AND SIGNATURE	DIGITAL SIGNATURE
Kushjee Pandey DMC/ARC/0027/2017			

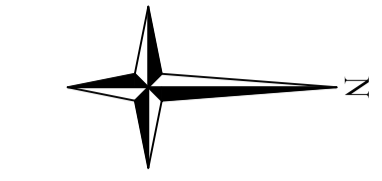

Proposal Basic Information	
Proposal File No.	DMC/BP/0178/W23/2023
Owner Name	(1) SRI PAWAN KUMAR AGARWAL (2) SRI SANTOSH KUMAR AGARWAL (3) SRI SANJAY KUMAR AGARWAL
Khata No	NEW -731, OLD- 68
Plot No	NEW -286&287, OLD -188&343
Village Name	Kolakusma
Use	Residential
SubUse	Bungalow/ Dwelling / Non Apartment

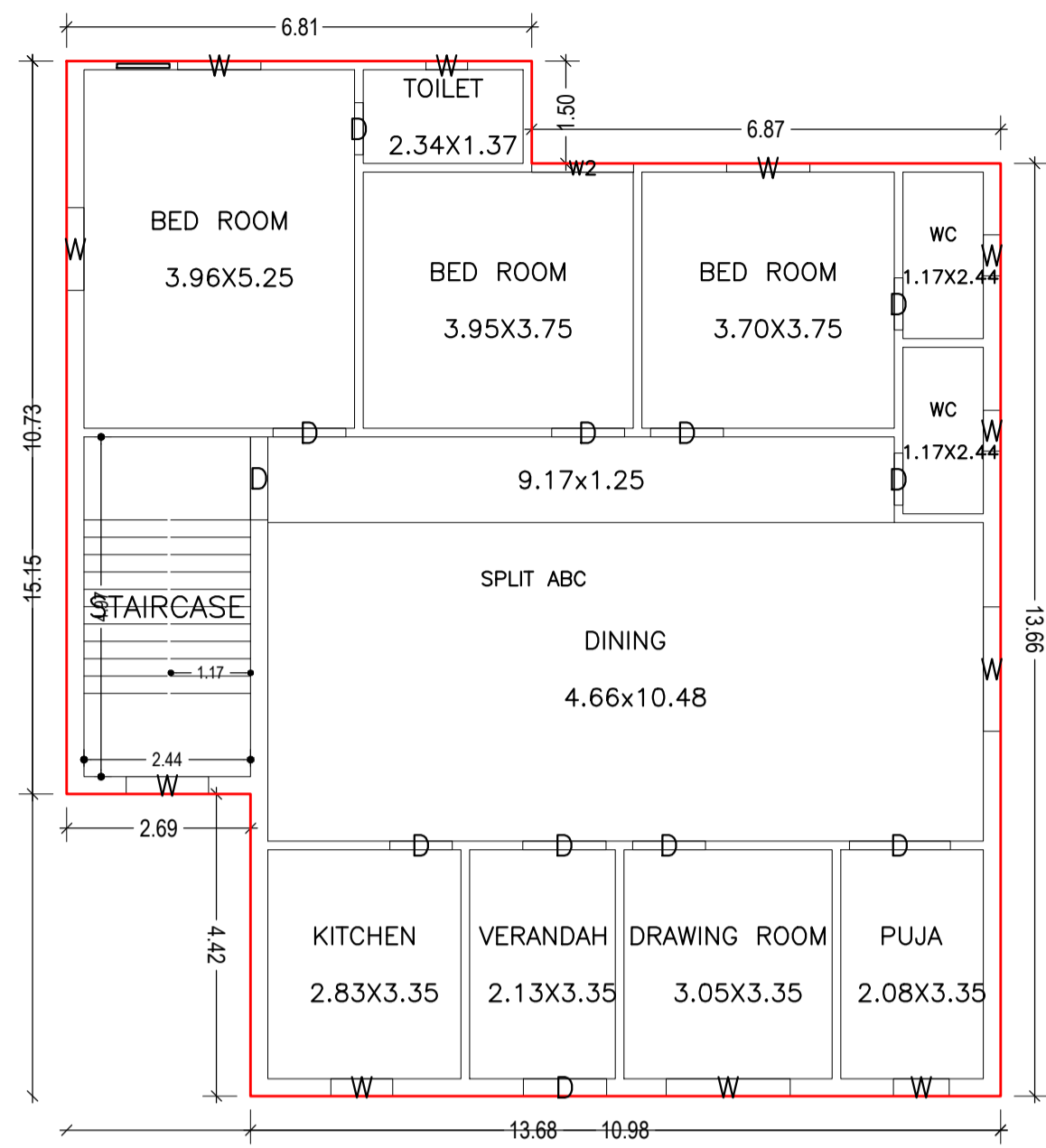

GROUND FLOOR PLAN
(Proposed)
(SCALE 1:100)

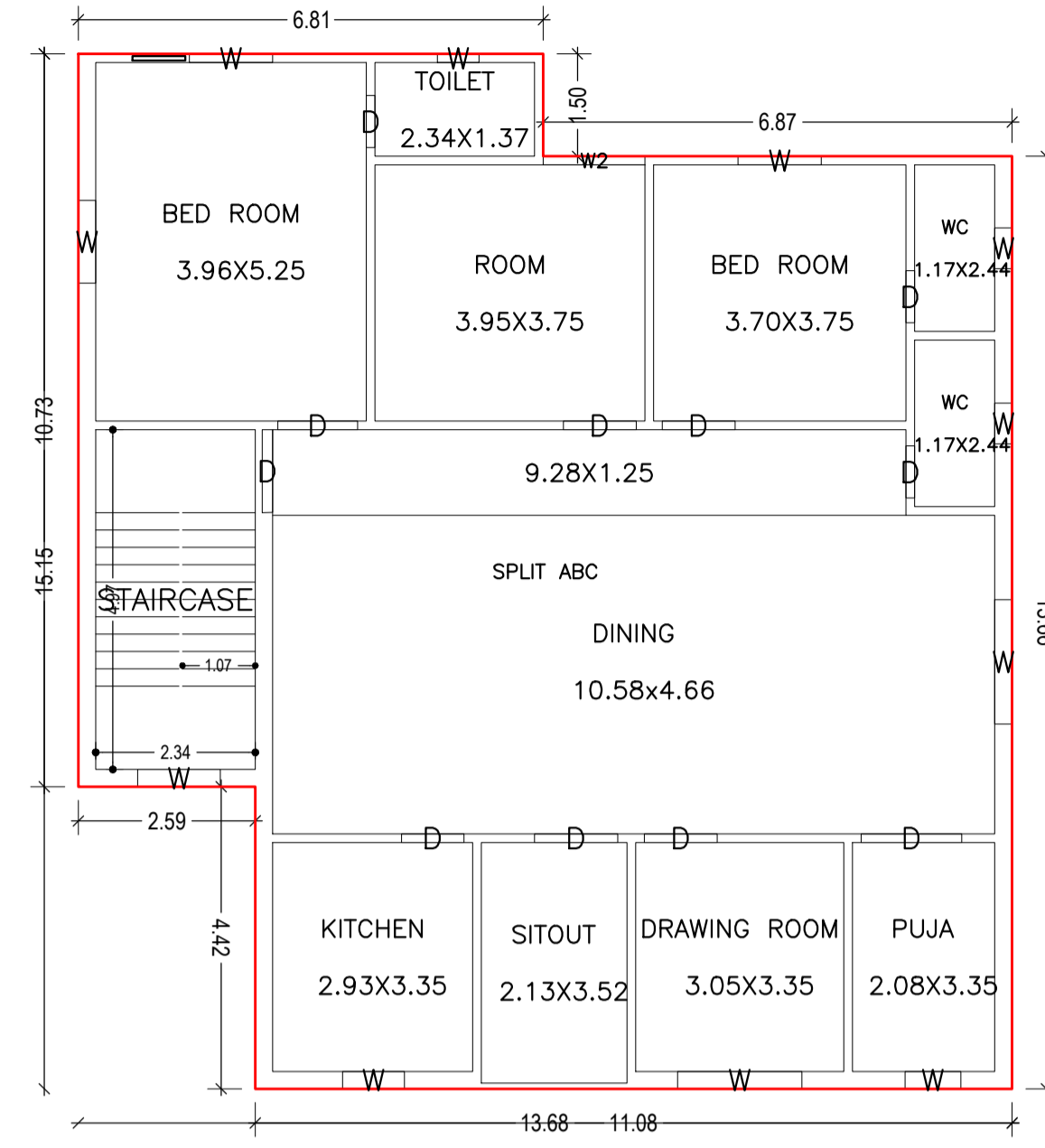

FIRST FLOOR PLAN
(Proposed)
(SCALE 1:100)

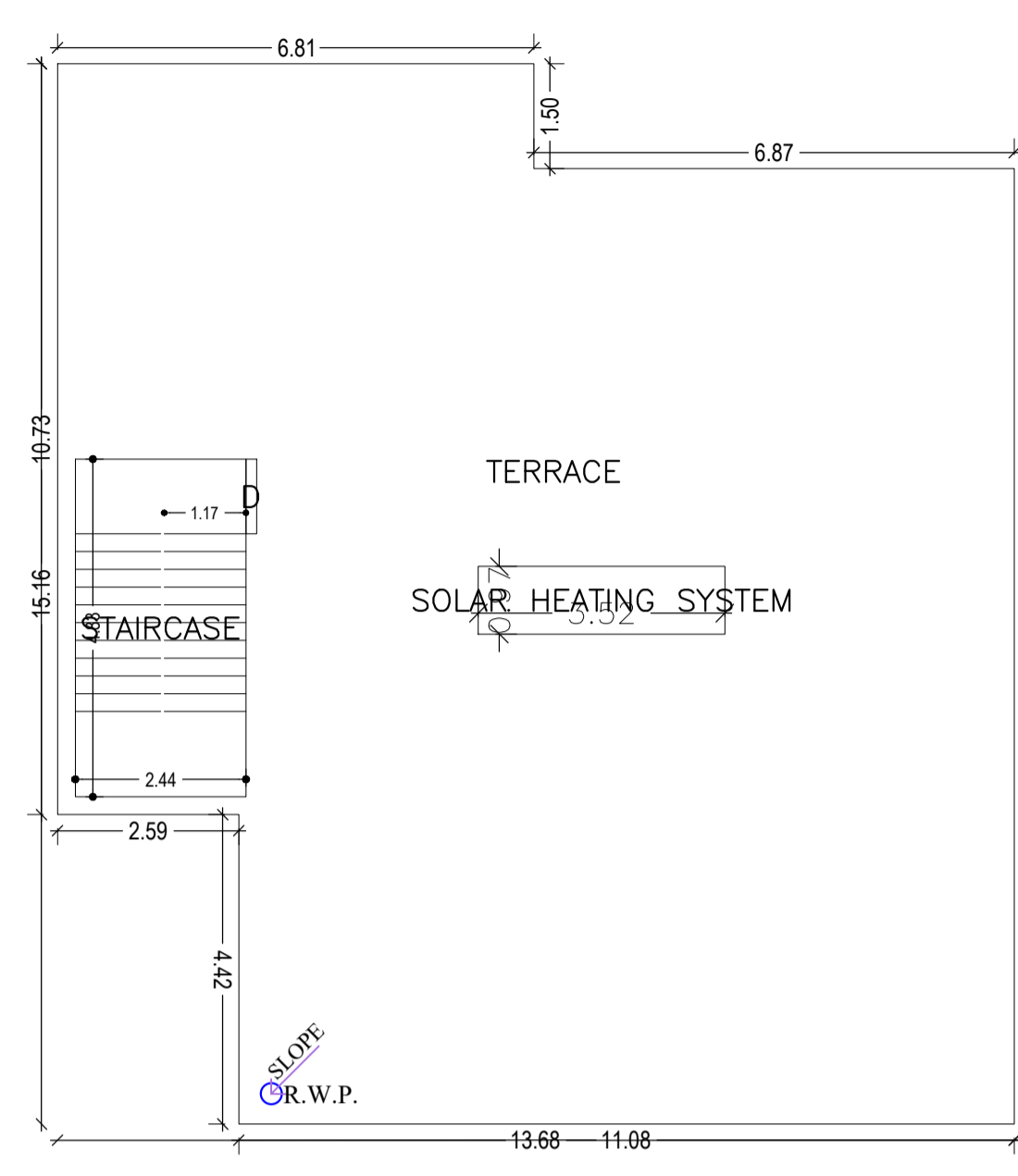

TERRACE FLOOR PLAN
(SCALE 1:100)

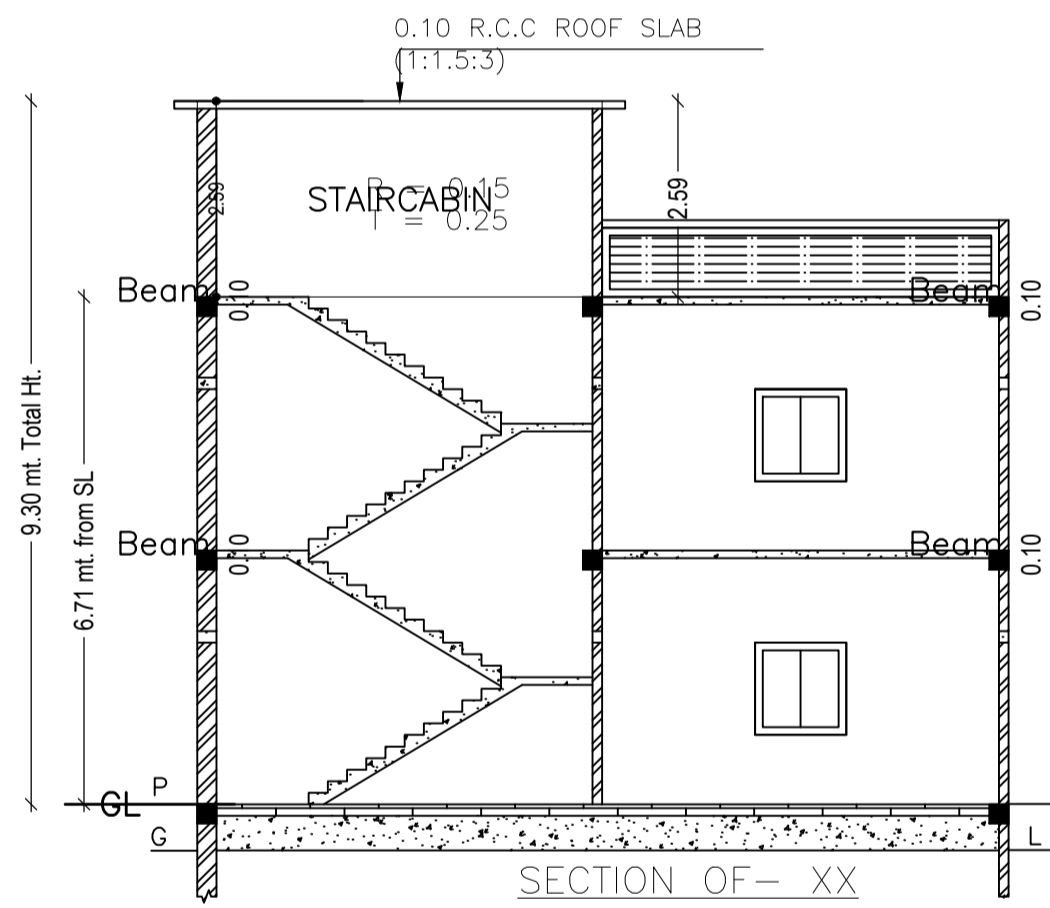
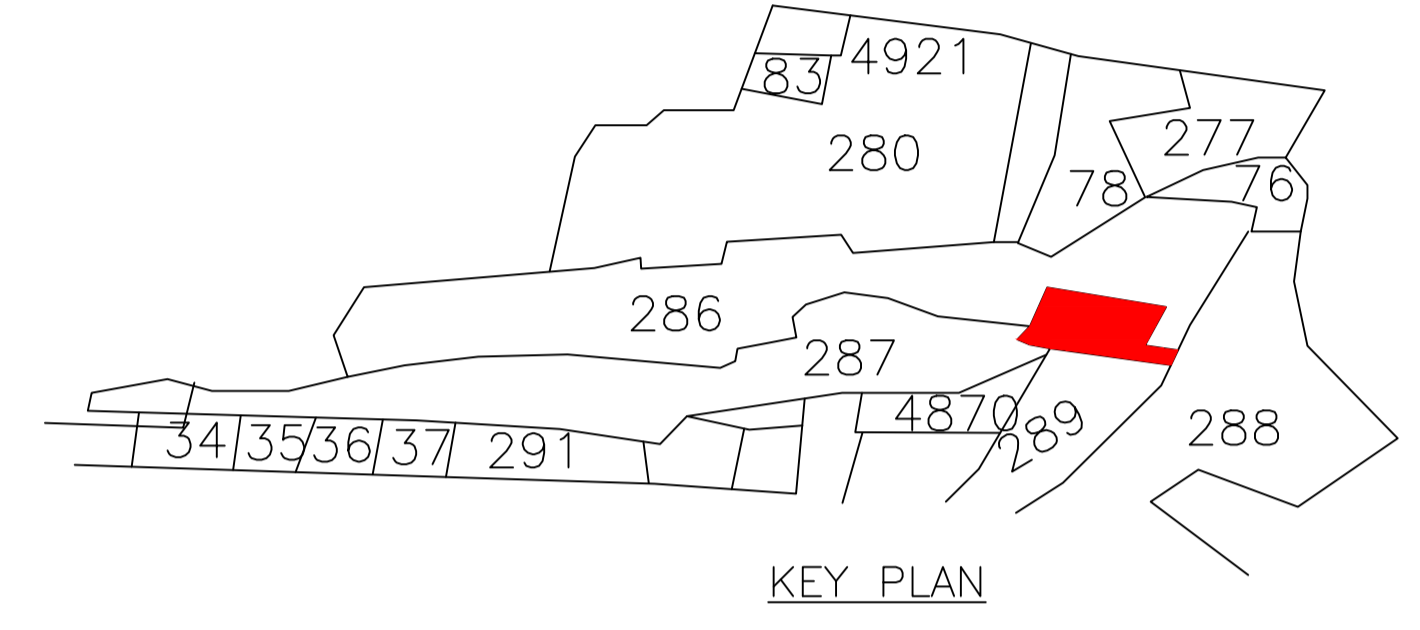
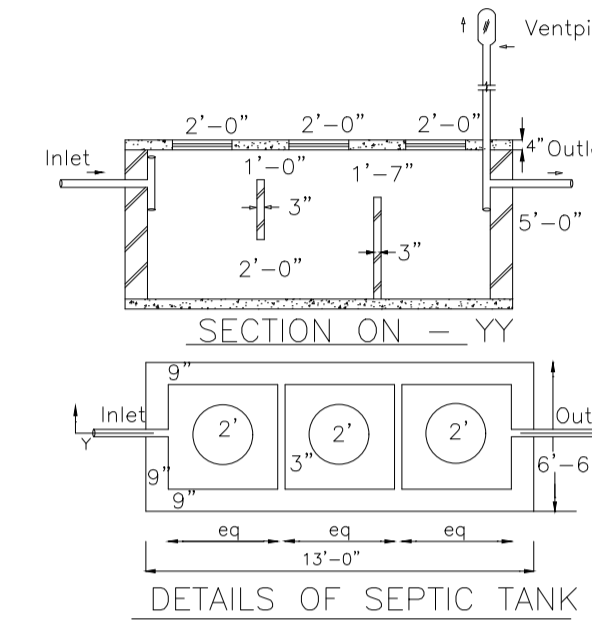

SECTION OF - XX

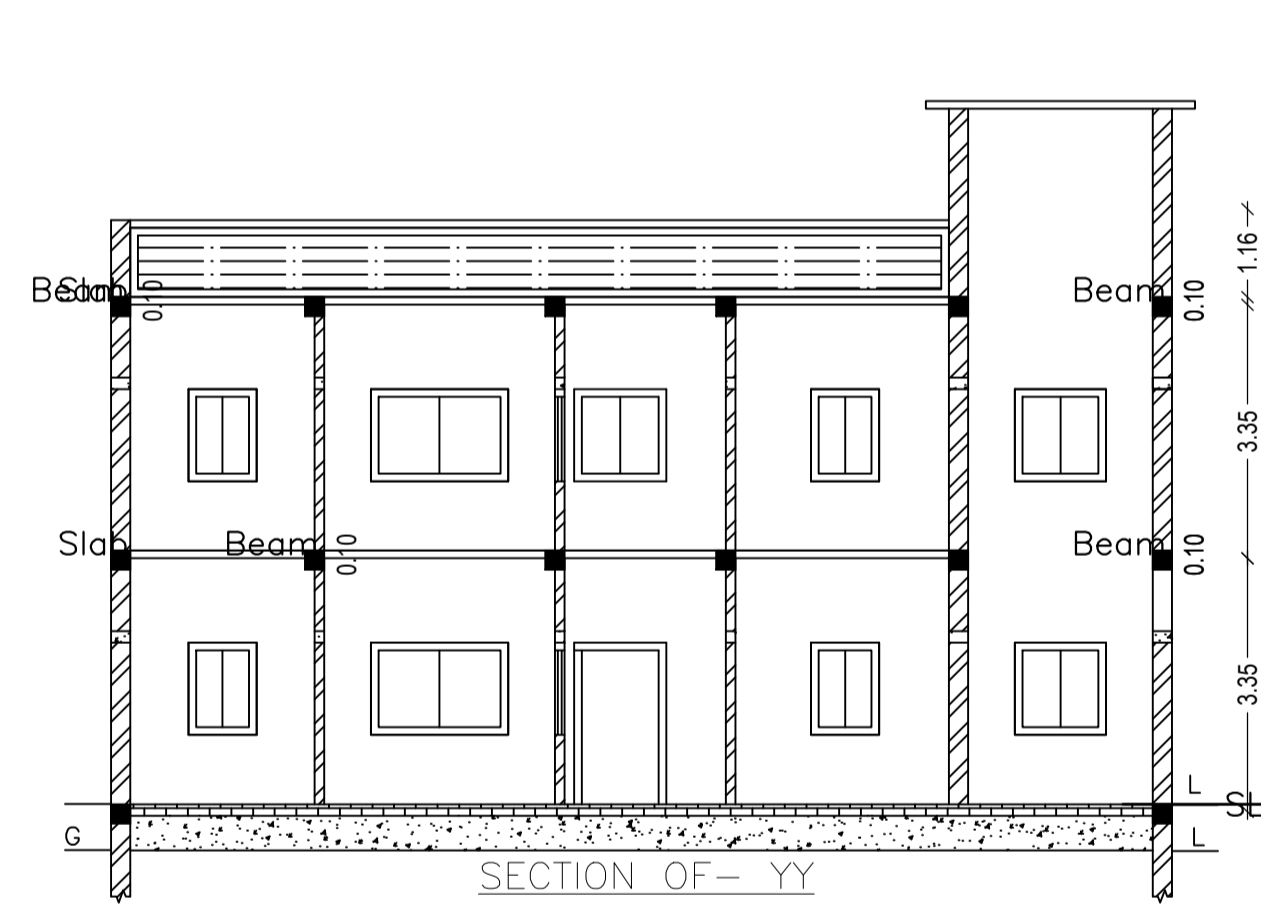

SECTION OF - YY

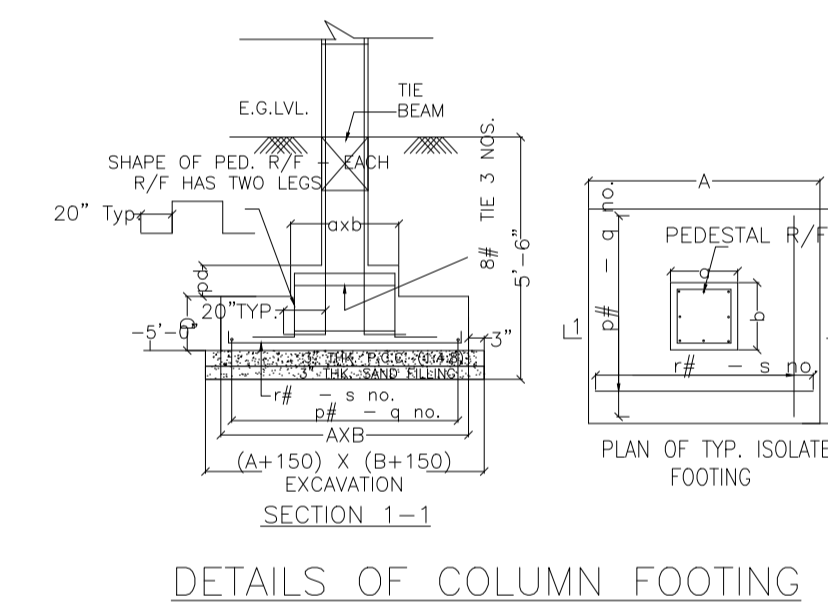

DETAILS OF COLUMN FOOTING

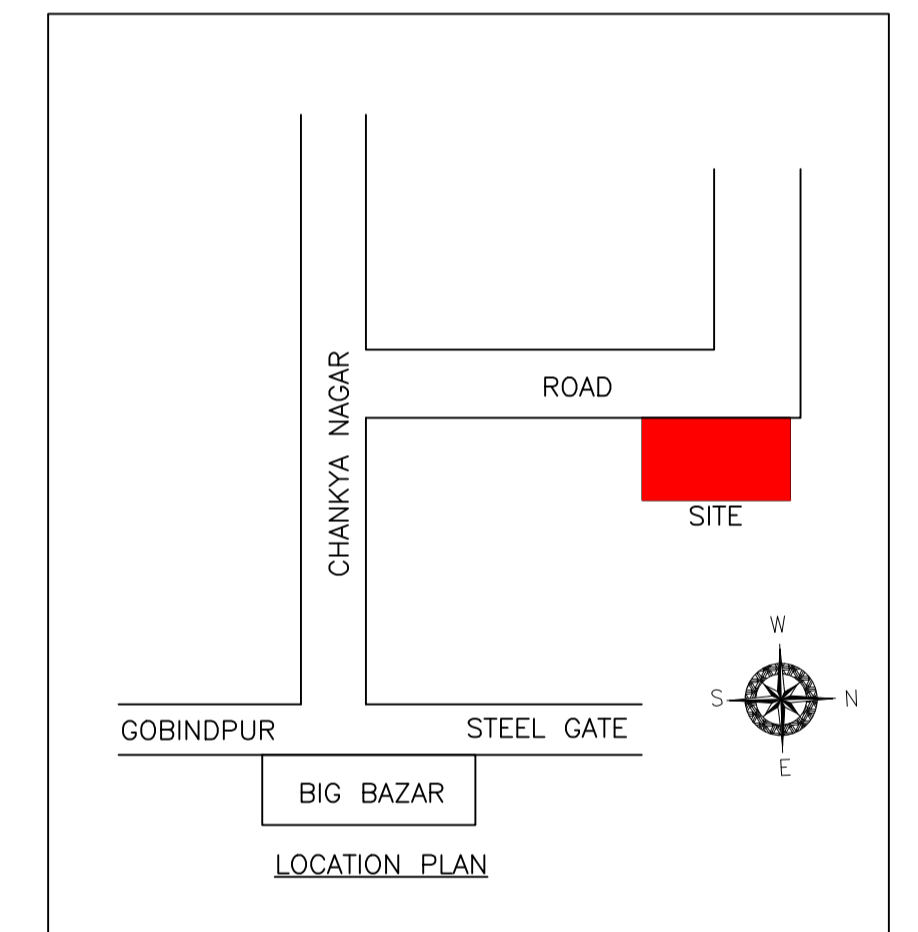

LOCATION PLAN

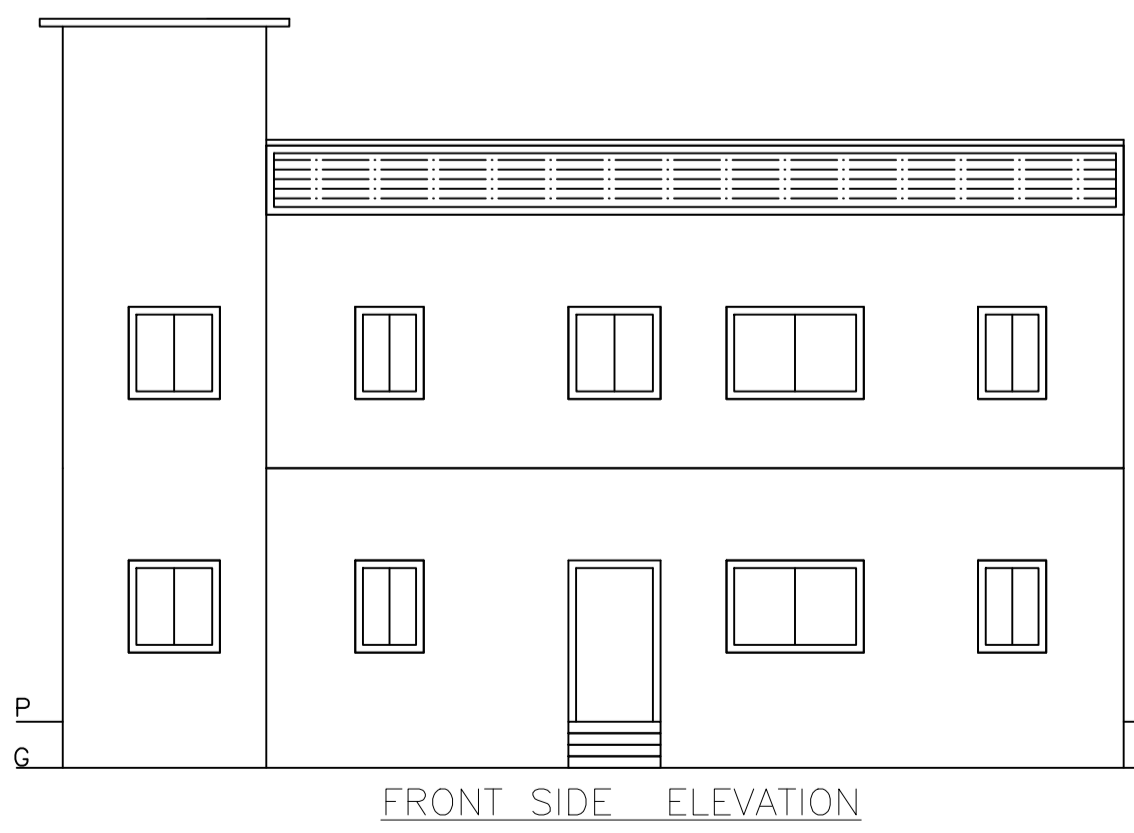

FRONT SIDE ELEVATION

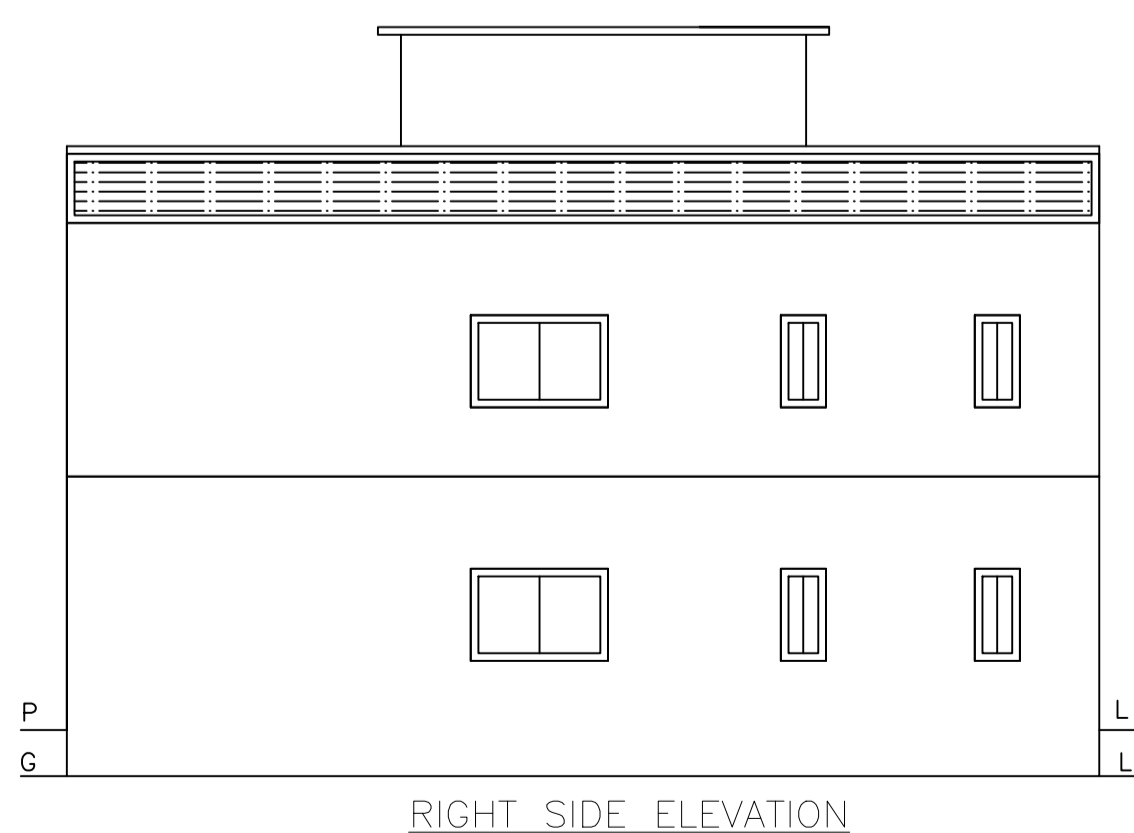

RIGHT SIDE ELEVATION

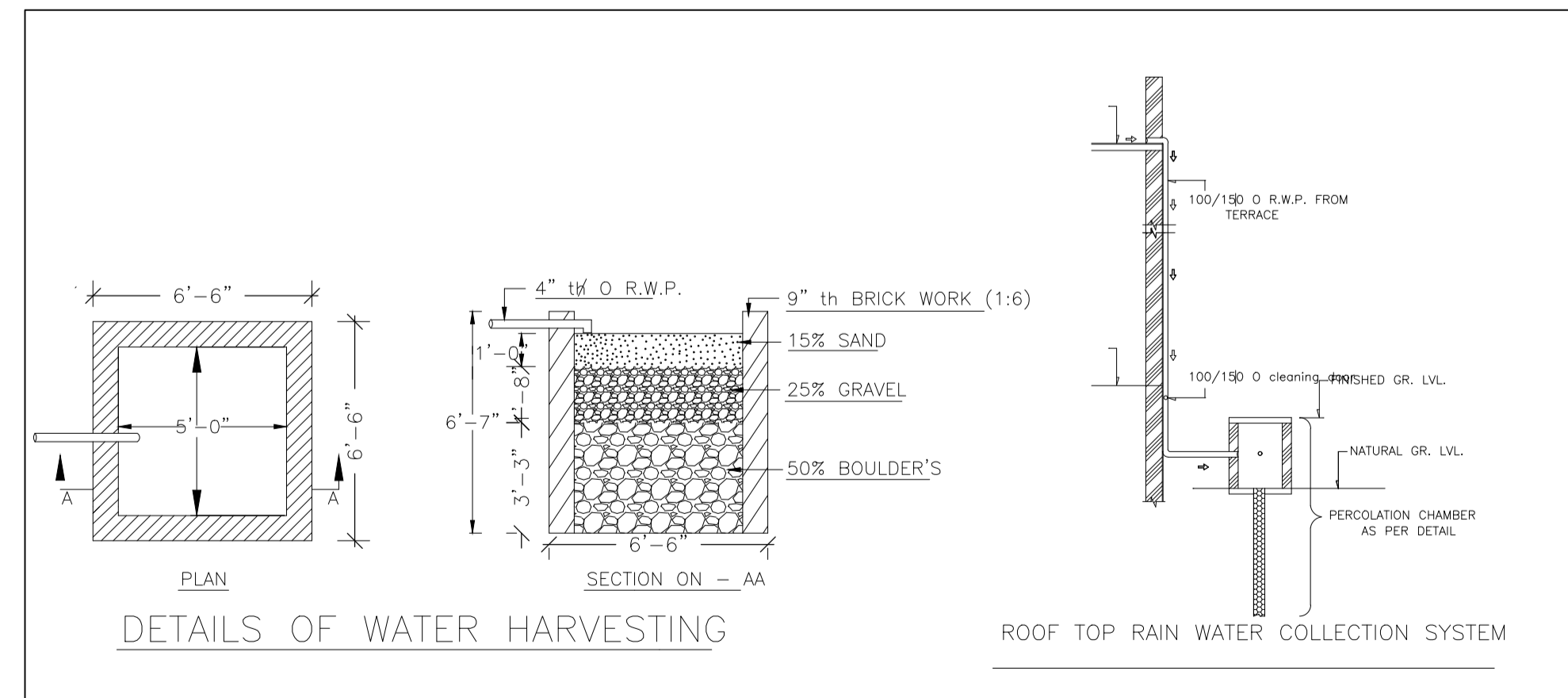

DETAILS OF WATER HARVESTING

ROOF TOP RAIN WATER COLLECTION SYSTEM

LTP NAME AND SIGNATURE	STRUCTURAL ENG'S NAME AND SIGNATURE	BUILDER NAME AND SIGNATURE	DIGITAL SIGNATURE
Kushjee Pandey DMC/ARC/0027/2017			