

15.92 mt.

SITE PLAN

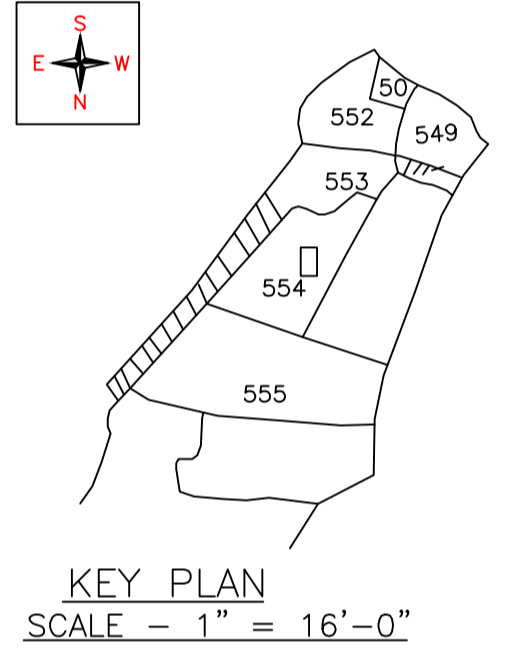

KEY PLAN
SCALE - 1" = 16'-0"

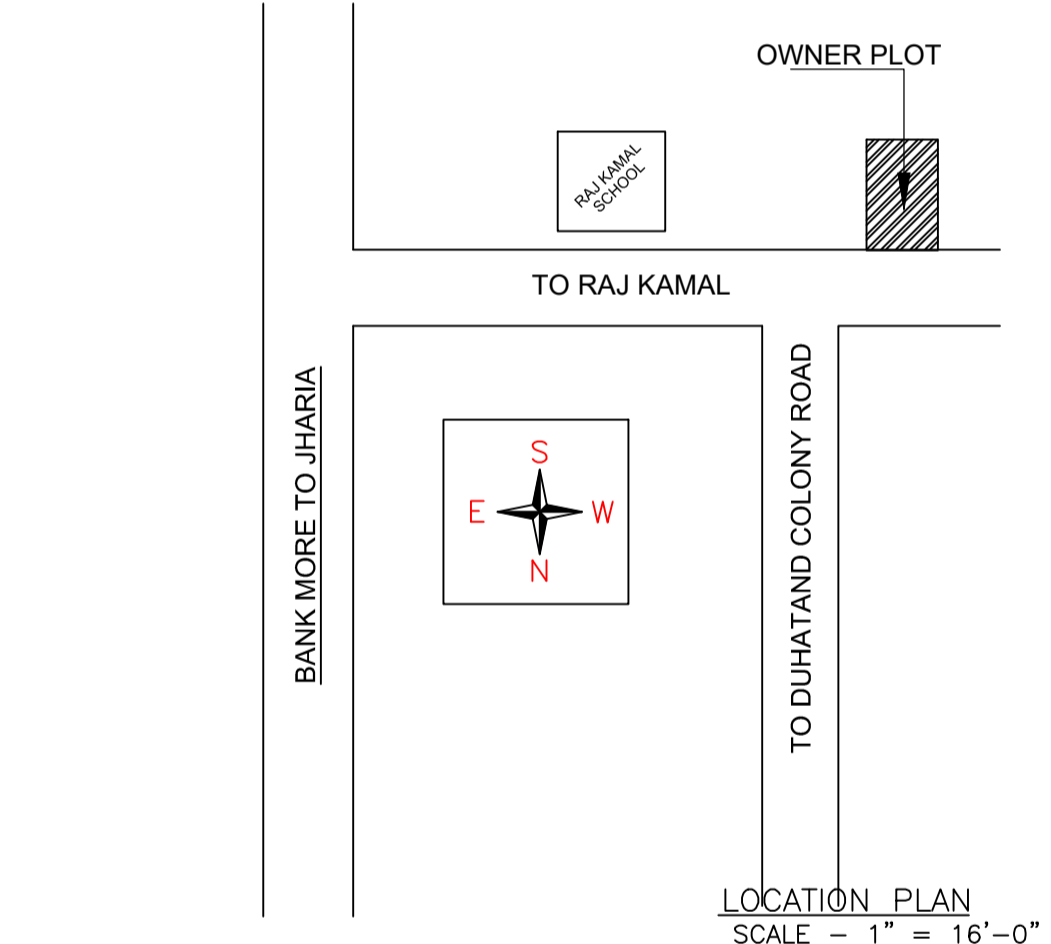

LOCATION PLAN
SCALE - 1" = 16'-0"

SCHEDULE OF DOOR:

BUILDING NAME	NAME	LENGTH	HEIGHT	NOS
A (BUILDING)	D	0.91	2.10	03
A (BUILDING)	D	1.06	2.10	30

SCHEDULE OF WINDOW/VENTILATION:

BUILDING NAME	NAME	LENGTH	HEIGHT	NOS
A (BUILDING)	W	0.90	1.20	06
A (BUILDING)	W	1.67	1.20	06
A (BUILDING)	W	1.80	1.20	27

Building :A (BUILDING)

Floor Name	Total Built Up Area (Sq.mt.)	Proposed FAR Area (Sq.mt.)	Total FAR Area (Sq.mt.)	Total Consumed Additional FAR Area (Sq.mt.)	Tnmt (No.)
Ground Floor	117.04	117.04	117.04	117.04	01
First Floor	117.04	117.04	117.04	117.04	00
Second Floor	117.04	117.04	117.04	117.04	00
Terrace Floor	0.00	0.00	0.00	0.00	00
Total :	351.12	351.12	351.12	351.12	01

FAR & Tenement Details (Table 4c-1)

Building	No. of Same Bldg	Total Built Up Area (Sq.mt.)	Proposed FAR Area (Sq.mt.)	Total FAR Area (Sq.mt.)	Total Consumed Additional FAR Area (Sq.mt.)	Tnmt (No.)
A (BUILDING)	1	351.12	351.12	351.12	351.12	01
Grand Total :	1	351.12	351.12	351.12	351.12	01

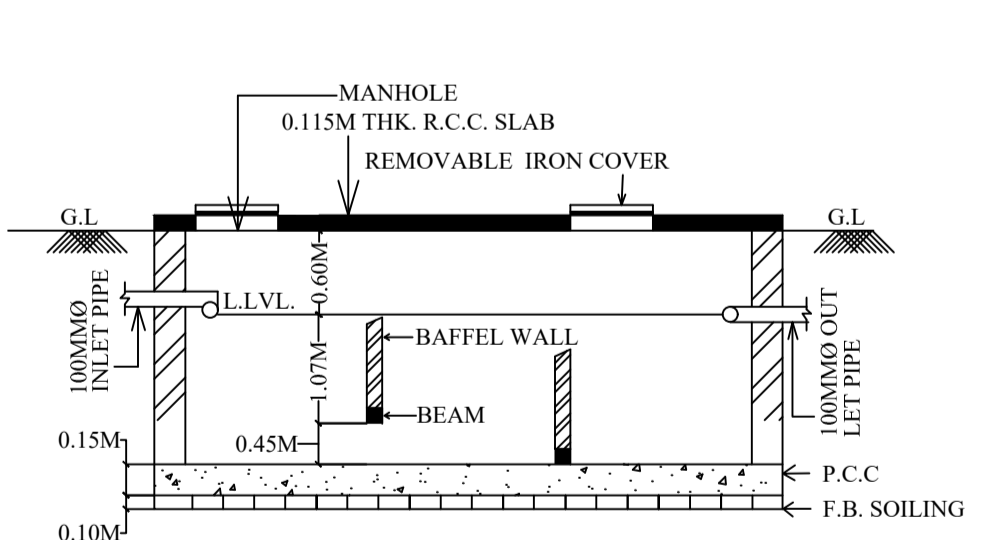

SECTION OF SEPTIC TANK.

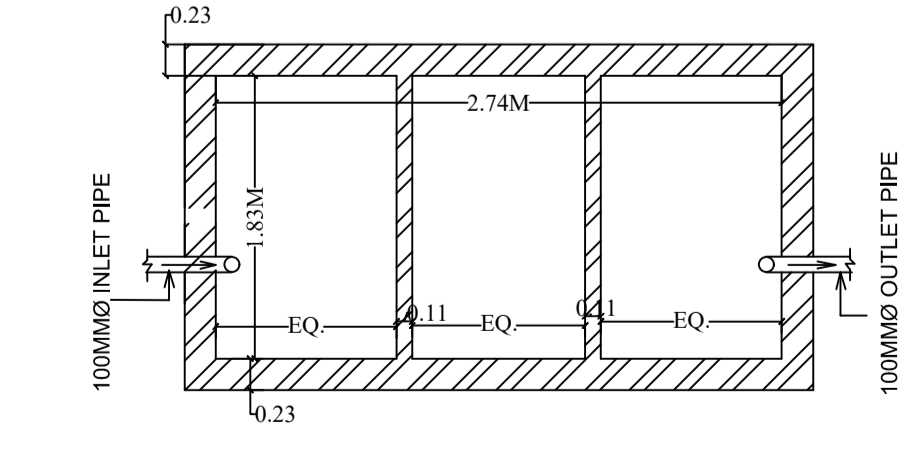

PLAN OF SEPTIC TANK.

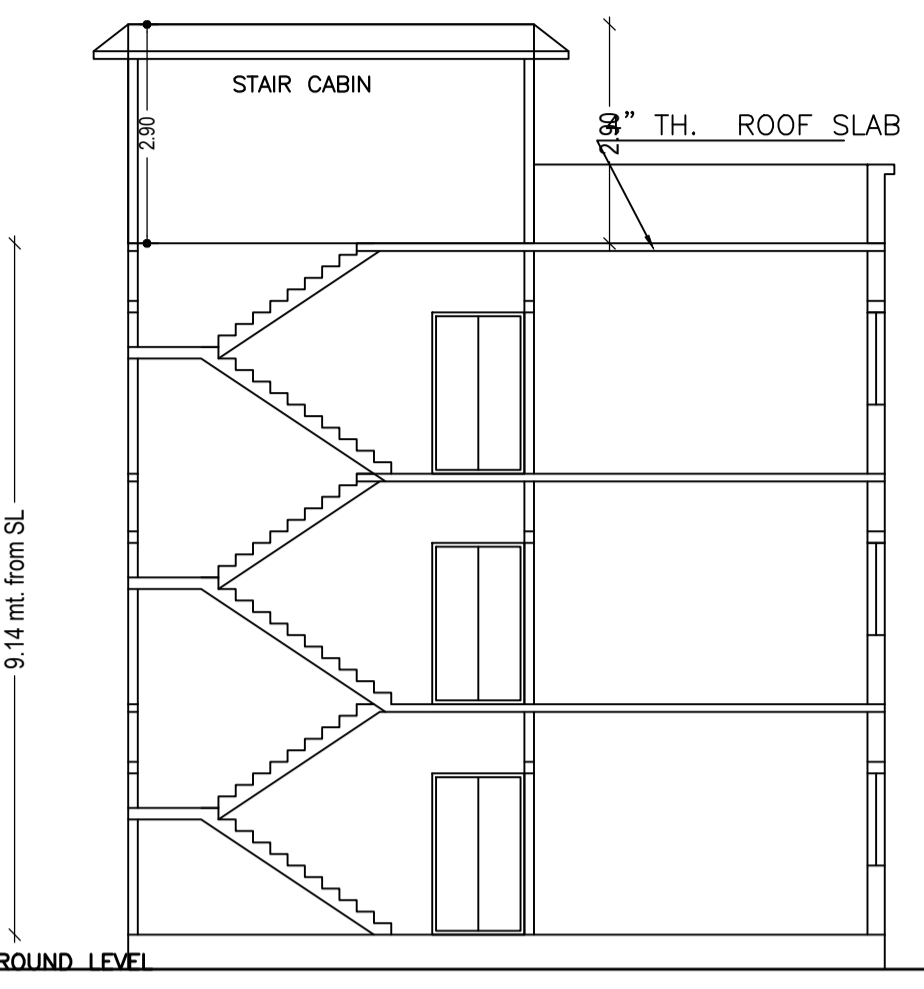

SECTION X-X

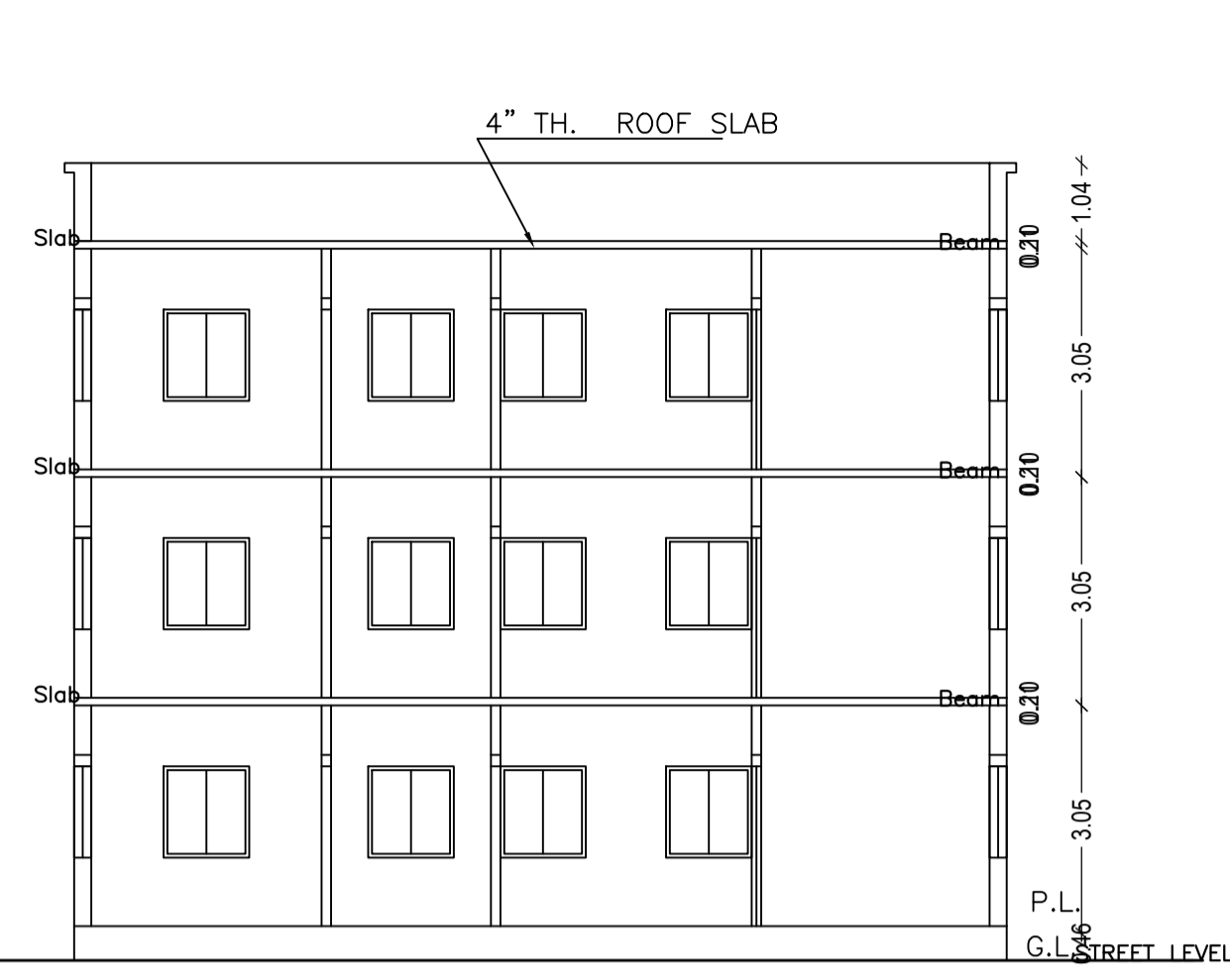

SECTION Y-Y

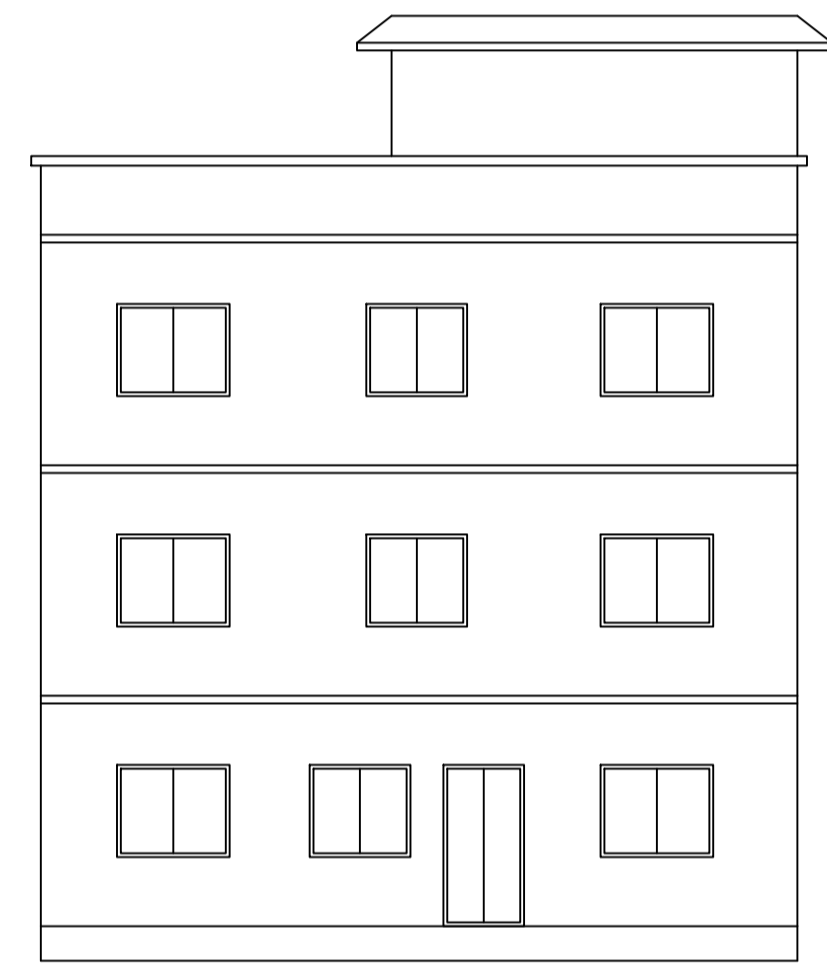

FRONT ELEVATION

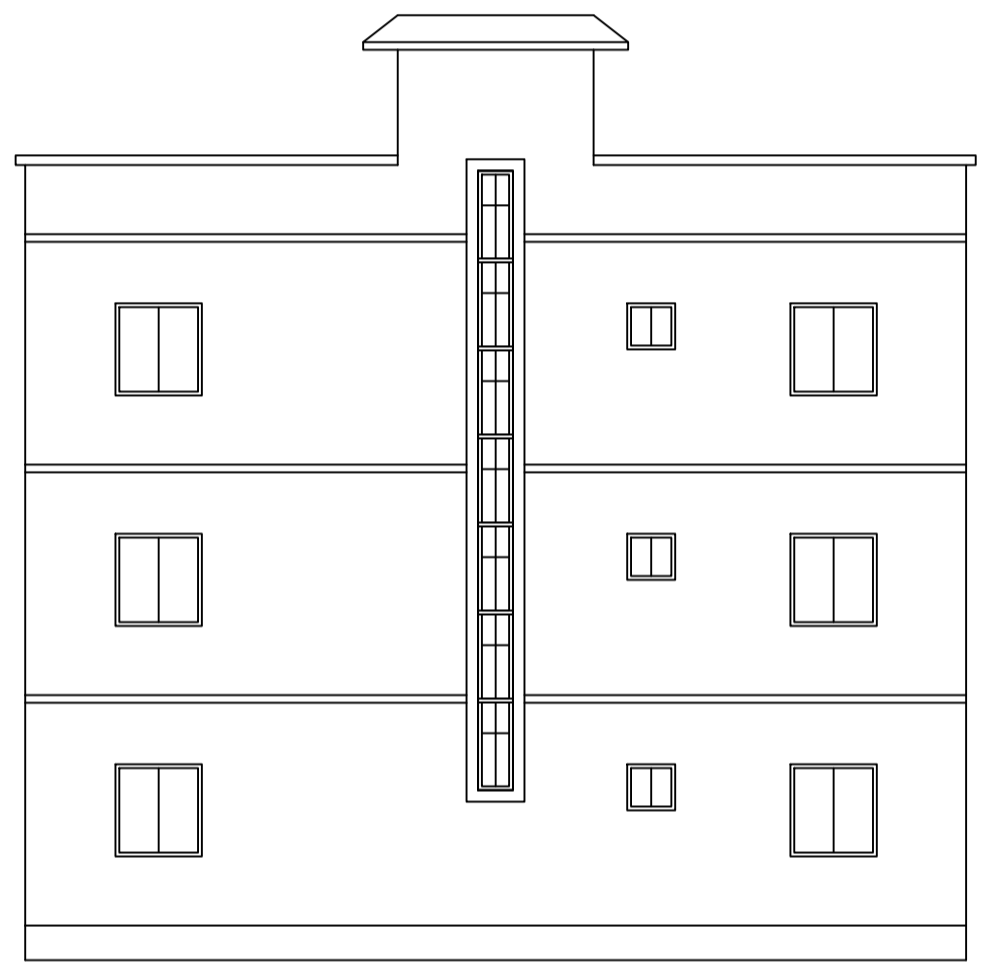

LEFT SIDE ELEVATION

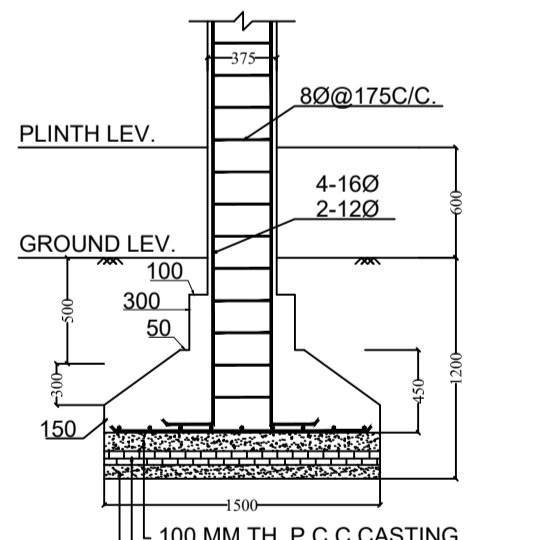

SECTION -(B-B)

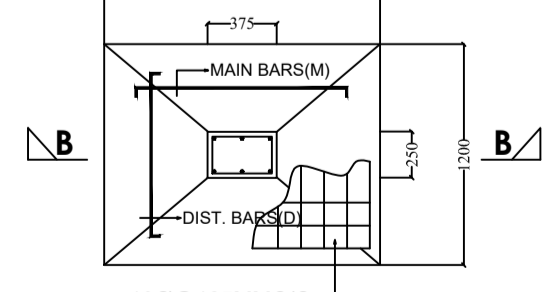

FOUNDATION PLAN OF CLOUMN

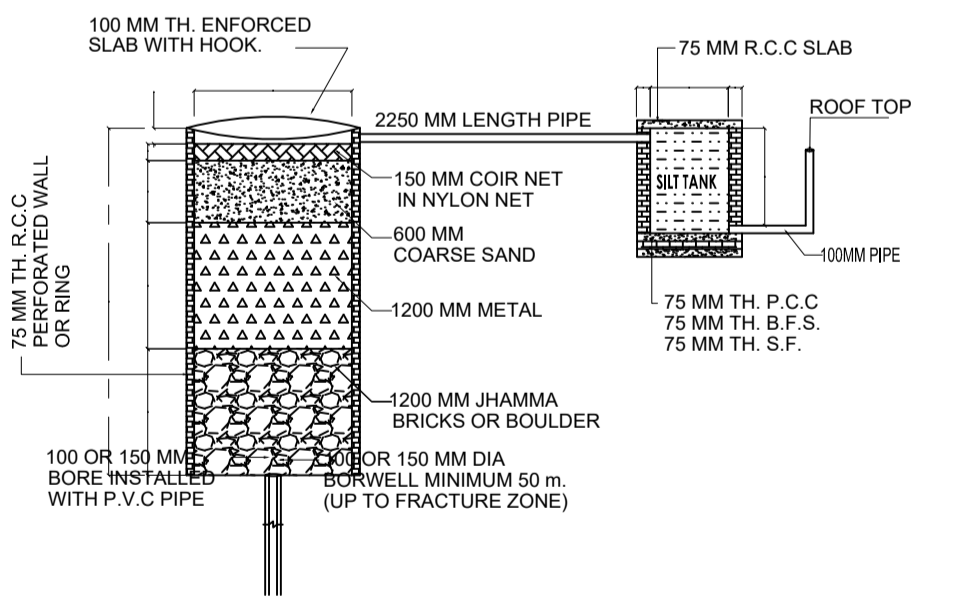

DETAIL OF GROUND WATER RECHARGING PIT WITH SILT TANK

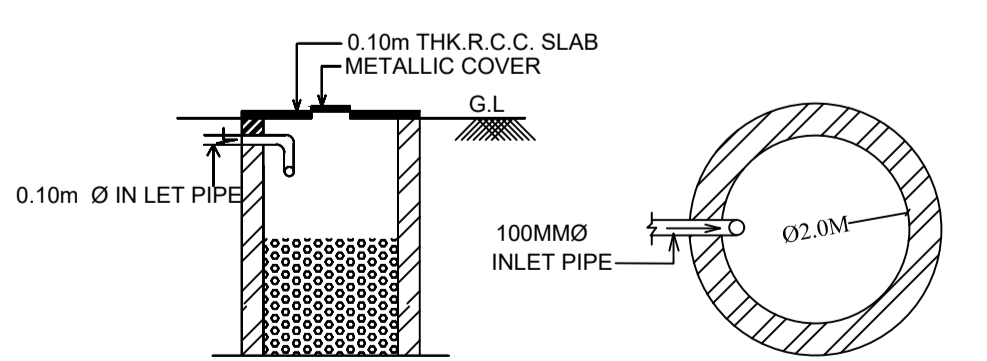

SECTION OF SOAK PIT

PLAN OF SOAK PIT

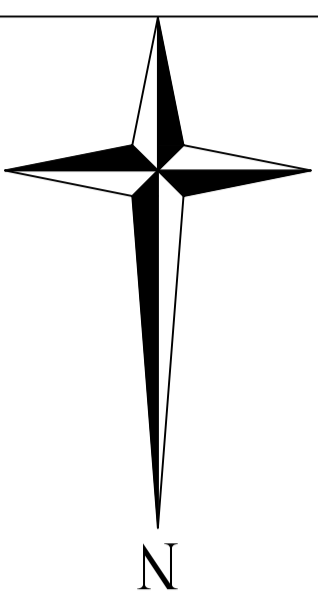

Proposal Basic Information

Proposal File No.	DMC/BP/0190/W33/2023
Owner Name	SMT REENA GUPTA
Khata No	91
Plot No	554
Village Name	Dhanbad
Use	Residential
SubUse	Bungalow/ Dwelling / Non Apartment

AREA STATEMENT		VERSION NO. : 1.0.66
DHANBAD MUNICIPAL CORPORATION		VERSION DATE: 16/10/2020
PROJECT DETAIL:		
Region: JHARKHAND URBAN LOCAL BODIES	Plot Use: Residential	
District: DHANBAD	Plot SubUse: Bungalow/ Dwelling / Non Apartment	
Authority: DHANBAD MUNICIPAL CORPORATION	Plot/Nearby/Religious/Structure: NA	
Inward No: DMC/BP/0190/W33/2023	Plot/SubPlot No: 554	
Application Type: General Proposal	North: Road Width - 6.10	
Project Type: Building Permission	South: Plot No. - smt meena devi Agarwala	
Nature of Development: New	East: Plot No. - building of Rikha devi Agarwala	
Location of Development Area: Old Area	West: Plot No. - land of Ram govind Agarwala	
AREA DETAILS:		SQ.MT.
AREA OF PLOT (Minimum)	(A)	194.80
Deduction for NetPlot Area		
Surrender Free of Cost		1.81
Total		1.81
NET AREA OF PLOT(Gross Plot Area - Deduction from Gross Plot area)	(A-Deductions)	192.99
Deduction for Balance Plot Area(from Gross Plot Area)		
Surrender Free of Cost		1.81
Common Plot		26.87
Total		28.68
BALANCE AREA OF PLOT(Net Plot Area - Recreational/Amenity space)	(A-Deductions)	166.12
PLOT AREA FOR COVERAGE(Net Plot Area)	(A-Deductions)	192.99
Plot Area for FAR (Net Plot Area + RoadWidening Area)	(A-Deductions)	194.80
COVERAGE CHECK		
Permissible Coverage area (70.00 %)		135.09
Proposed Coverage Area (60.65 %)		117.04
Total Prop. Coverage Area (60.65 %)		117.04
Balance coverage area (9.35 %)		18.05
FAR CHECK		
Perm. FAR Area (2.500)		487.00
Total Perm. FAR area		487.00
Residential FAR		351.11
Proposed FAR Area		351.11
Total Proposed FAR Area		351.11
Consumed FAR (Factor)		1.80
Balance FAR Area		135.89
BUILT UP AREA CHECK		
Total Proposed BuiltUp Area		351.12
ARCHITECT (Regd)		AAKASH KUMAR
ENGINEER (Regd)		
SUPERVISOR (Regd)		
OWNER (Regd)		SMT REENA GUPTA
DEVELOPMENT AUTHORITY		LOCAL BODY

COLOR INDEX

PLOT BOUNDARY	Black
ABUTTING ROAD	Green
PROPOSED CONSTRUCTION	Red
COMMON PLOT	Yellow
ROAD WIDENING AREA	Blue
EXISTING (To be retained)	Orange
EXISTING (To be demolished)	Light Blue

Buildingwise Floor FAR Details

Floor Name	Building Name A (BUILDING)		Total	
	Proposed Built Up Area (Sq.mt.)	Proposed FAR Area (Sq.mt.)	Total Proposed Built Up Area (Sq.mt.)	Total FAR Area (Sq.mt.)
Ground Floor	117.04	117.04	117.04	117.04
First Floor	117.04	117.04	117.04	117.04
Second Floor	117.04	117.04	117.04	117.04
Terrace Floor	0.00	0.00	0.00	0.00
Total :	351.12	351.12	351.12	351.12

Building USE/SUBUSE Details

Building Name	Building Use	Building SubUse	Building Structure
A (BUILDING)	Residential	Bungalow/ Dwelling / Non Apartment	Non-Highrise

UnitBUA Table for Building :A (BUILDING)

FLOOR	Name	UnitBUA Type	UnitBUA Area	Carpet Area	No. of Rooms	No. of Tenement
GROUND FLOOR PLAN	SPLIT FLAT - A	FLAT	351.11	351.04	10	1
TYPICAL -1 & 2 FLOOR PLAN	SPLIT FLAT - A	FLAT	0.00	0.00	10	0
Total:	-	-	351.11	351.04	30	1

LTP NAME AND SIGNATURE	STRUCTURAL ENG'S NAME AND SIGNATURE	BUILDER NAME AND SIGNATURE	DIGITAL SIGNATURE
AAKASH KUMAR DMC/ENG/0019/2017			

Proposal Basic Information	
Proposal File No.	DMC/BP/0190/W33/2023
Owner Name	SMT REENA GUPTA
Khata No	91
Plot No	554
Village Name	Dhanbad
Use	Residential
SubUse	Bungalow/ Dwelling / Non Apartment

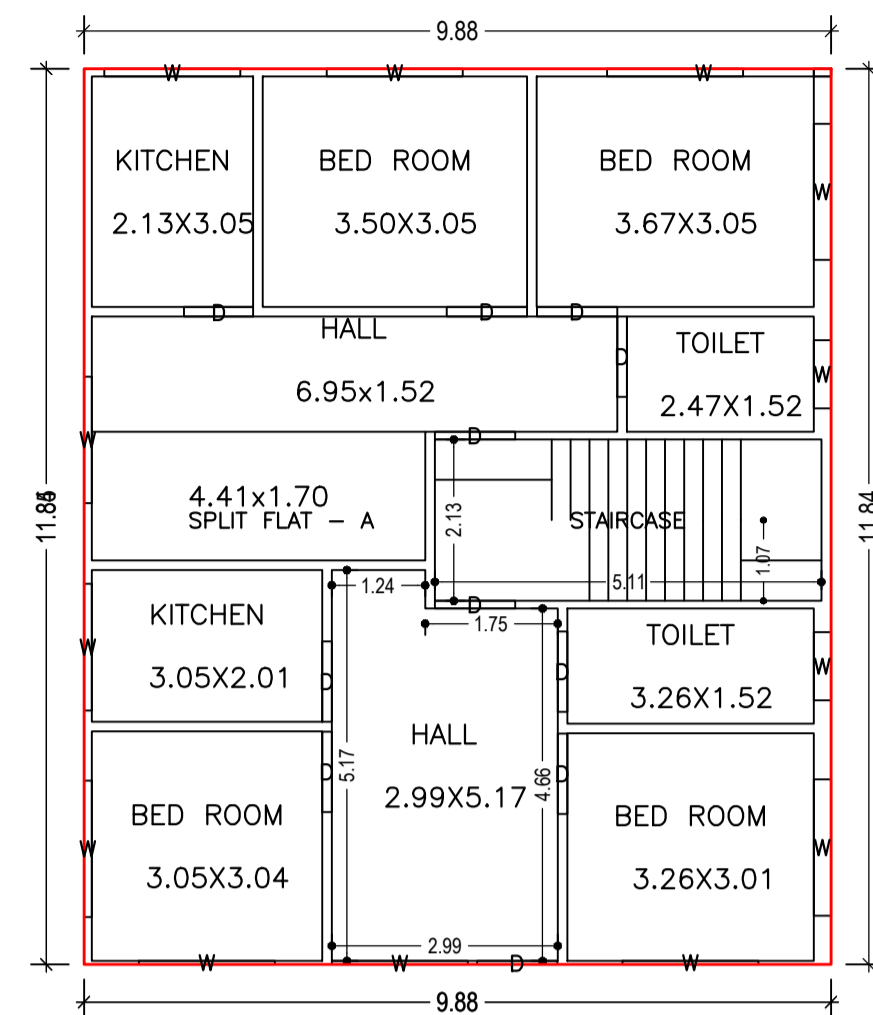
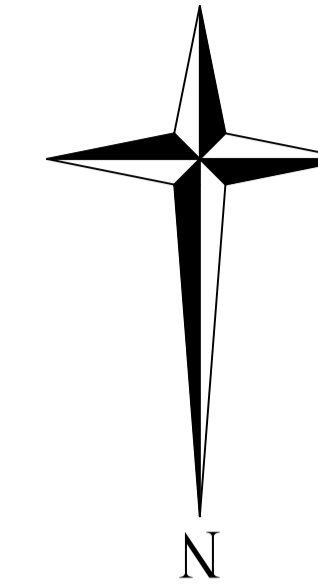

GROUND FLOOR PLAN
(Proposed)
(SCALE 1:100)

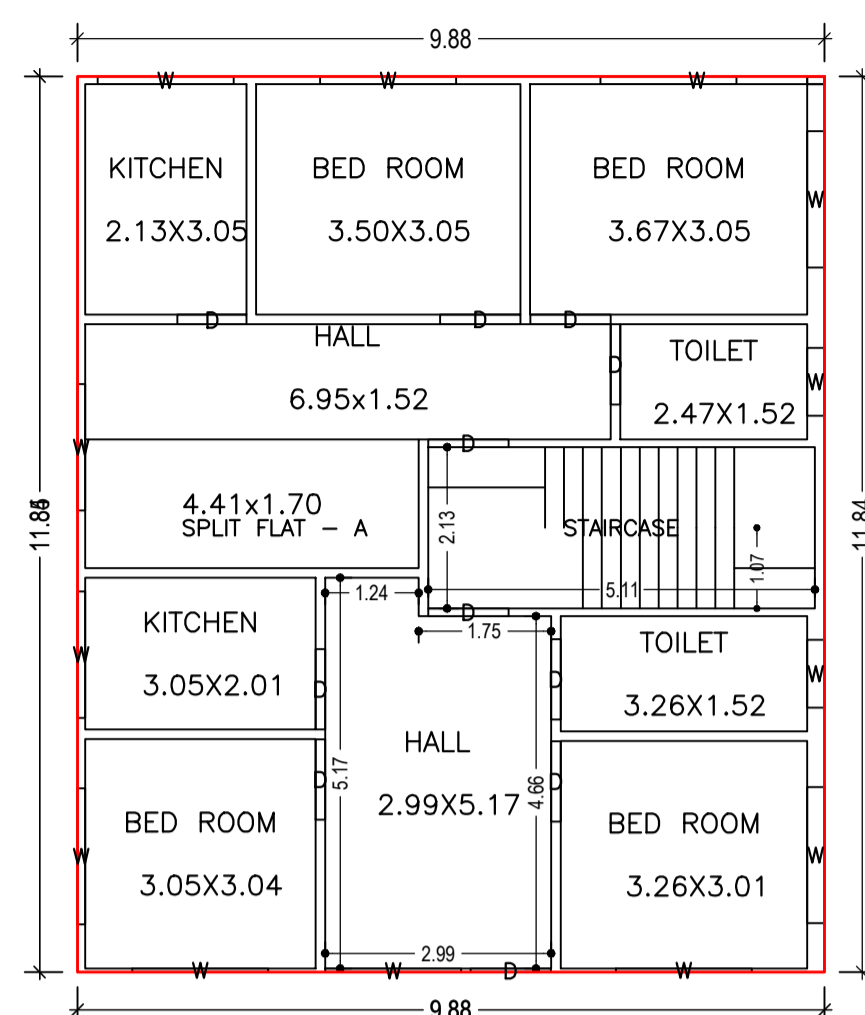

TYPICAL - 1 & 2 FLOOR PLAN
(Proposed)
(SCALE 1:100)

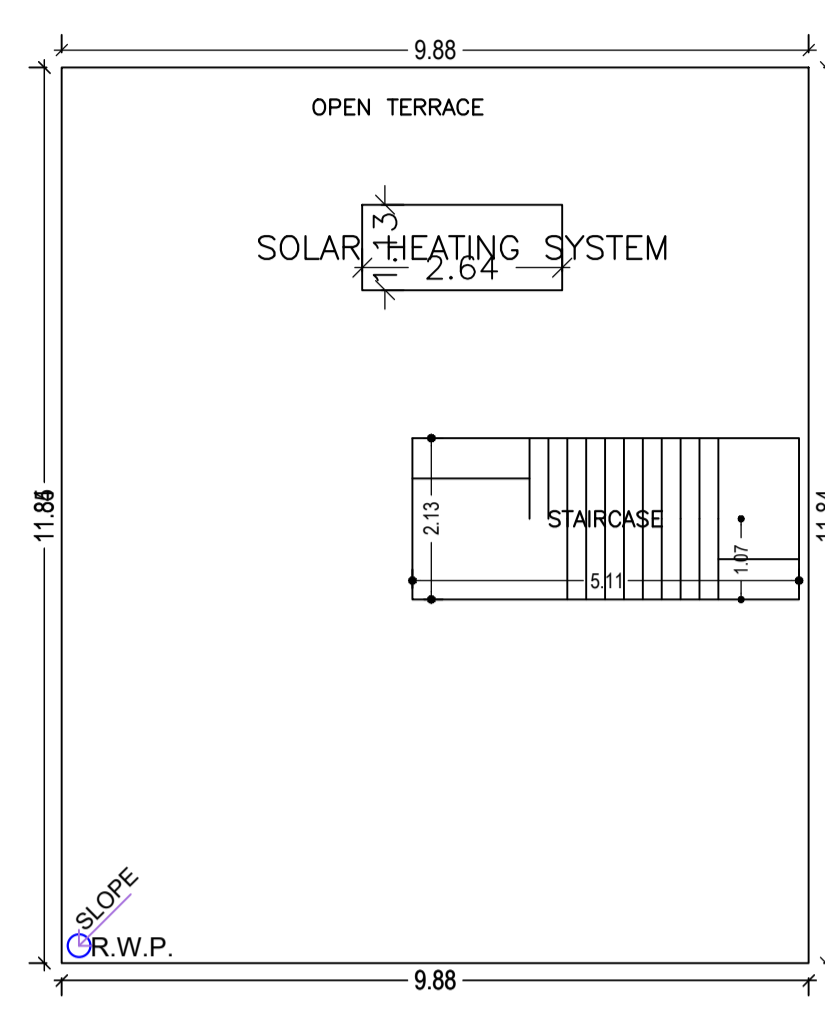

TERRACE FLOOR PLAN
(SCALE 1:100)

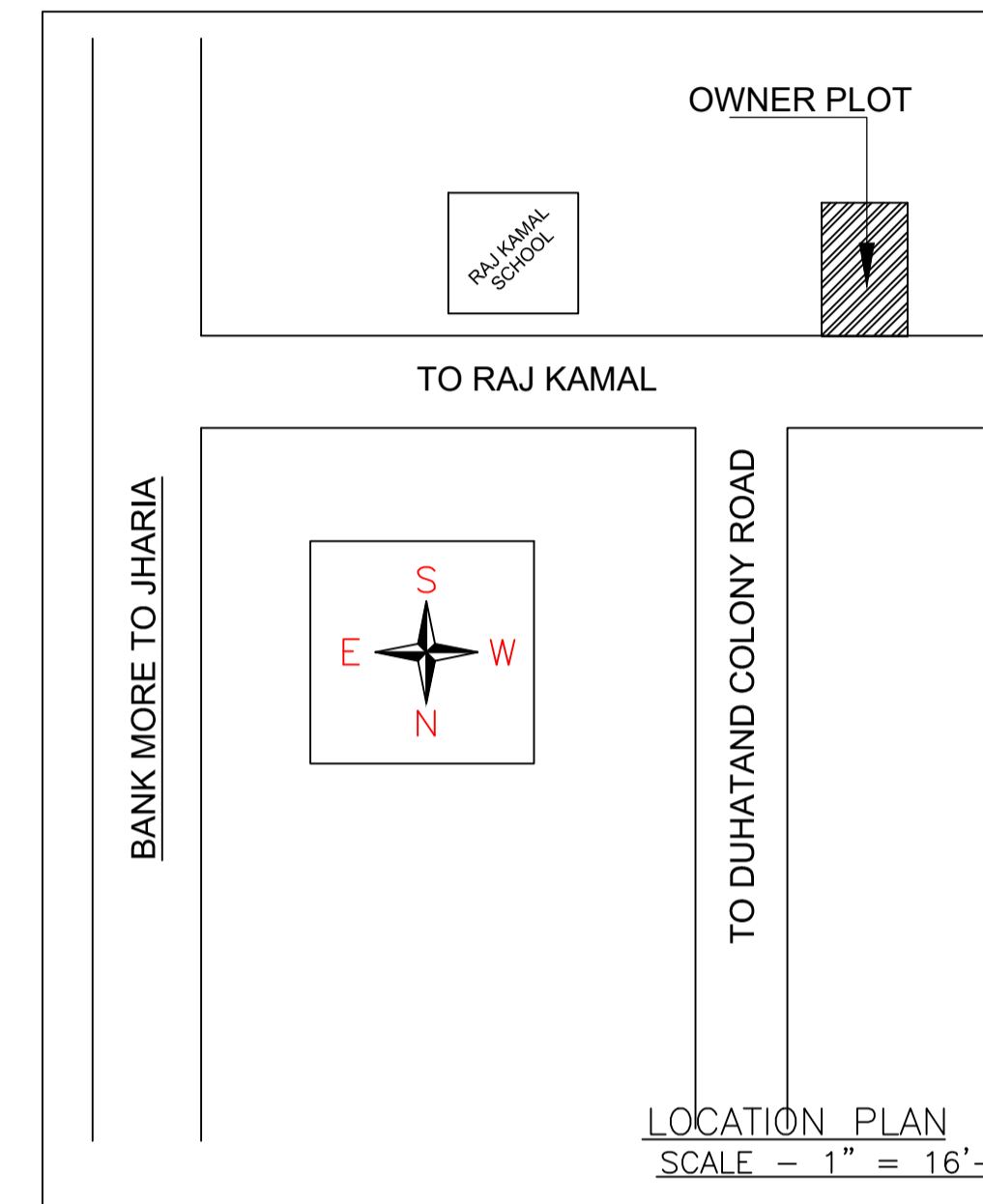

LOCATION PLAN
SCALE - 1" = 16'-0"

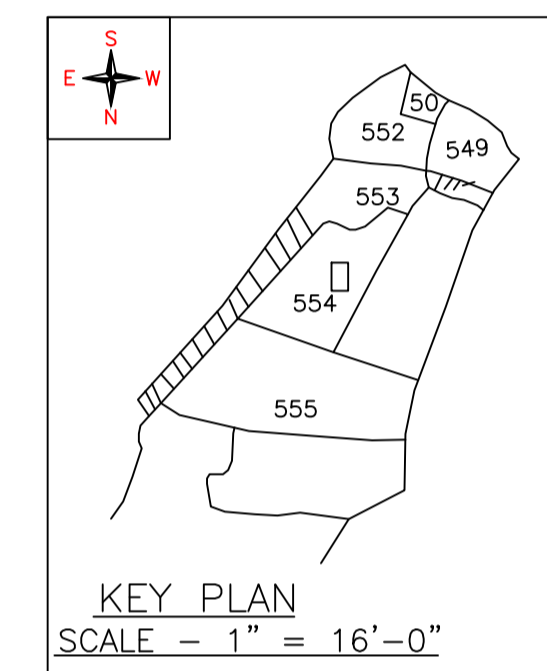

KEY PLAN
SCALE - 1" = 16'-0"

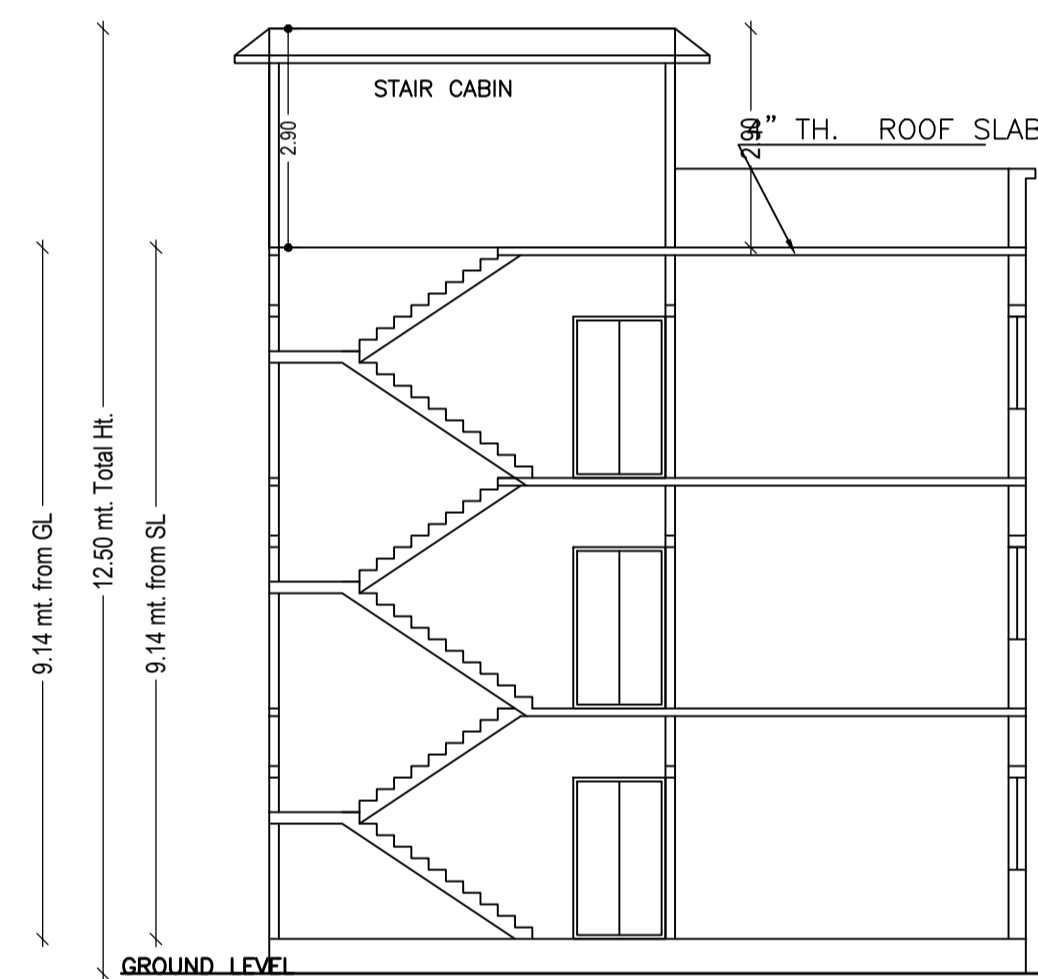

SECTION X-X

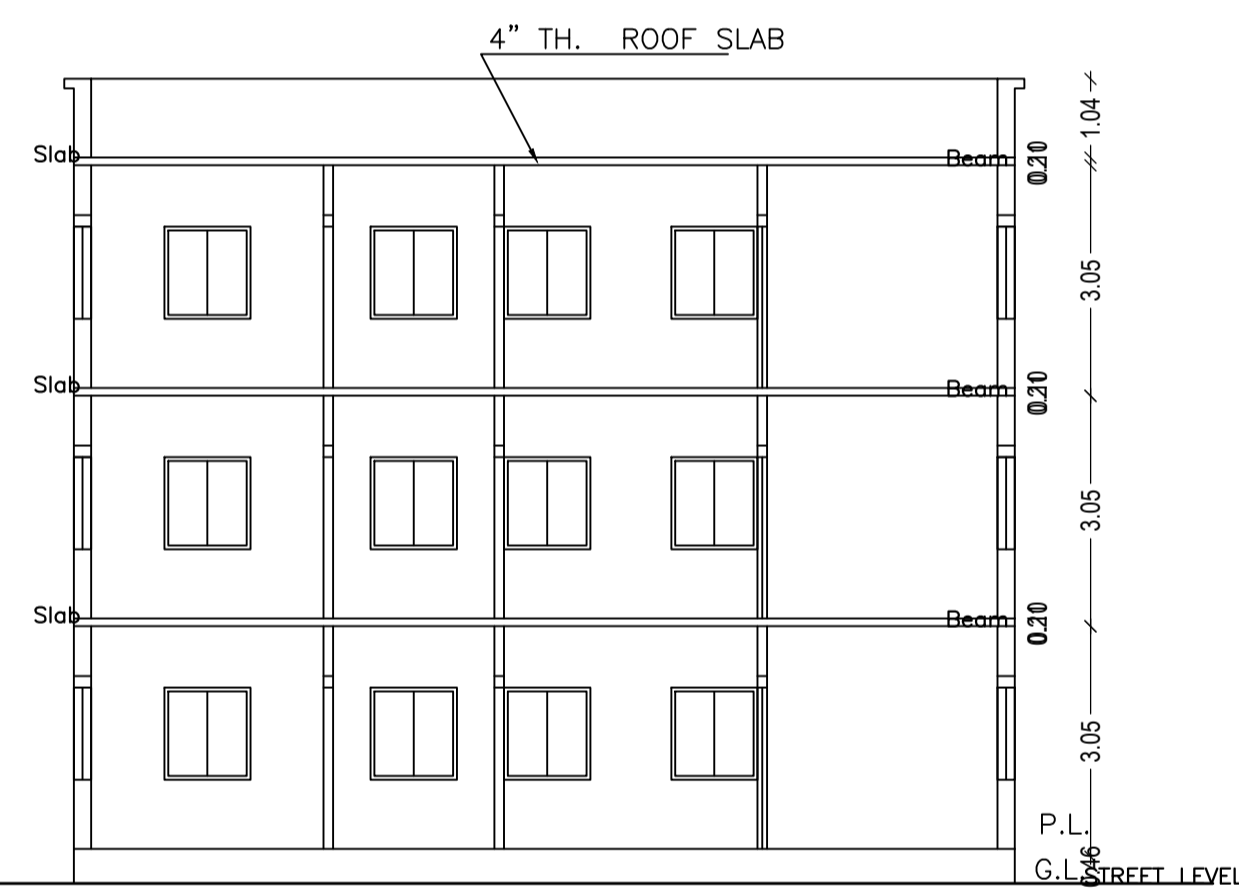

SECTION Y-Y

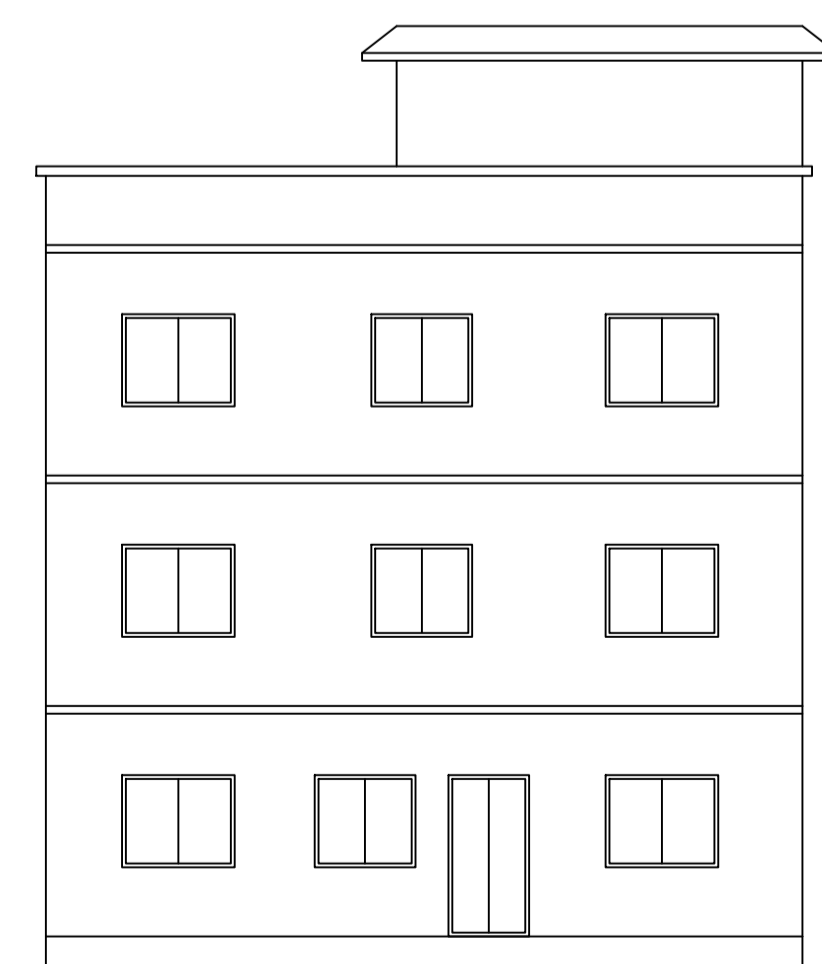

FRONT ELEVATION

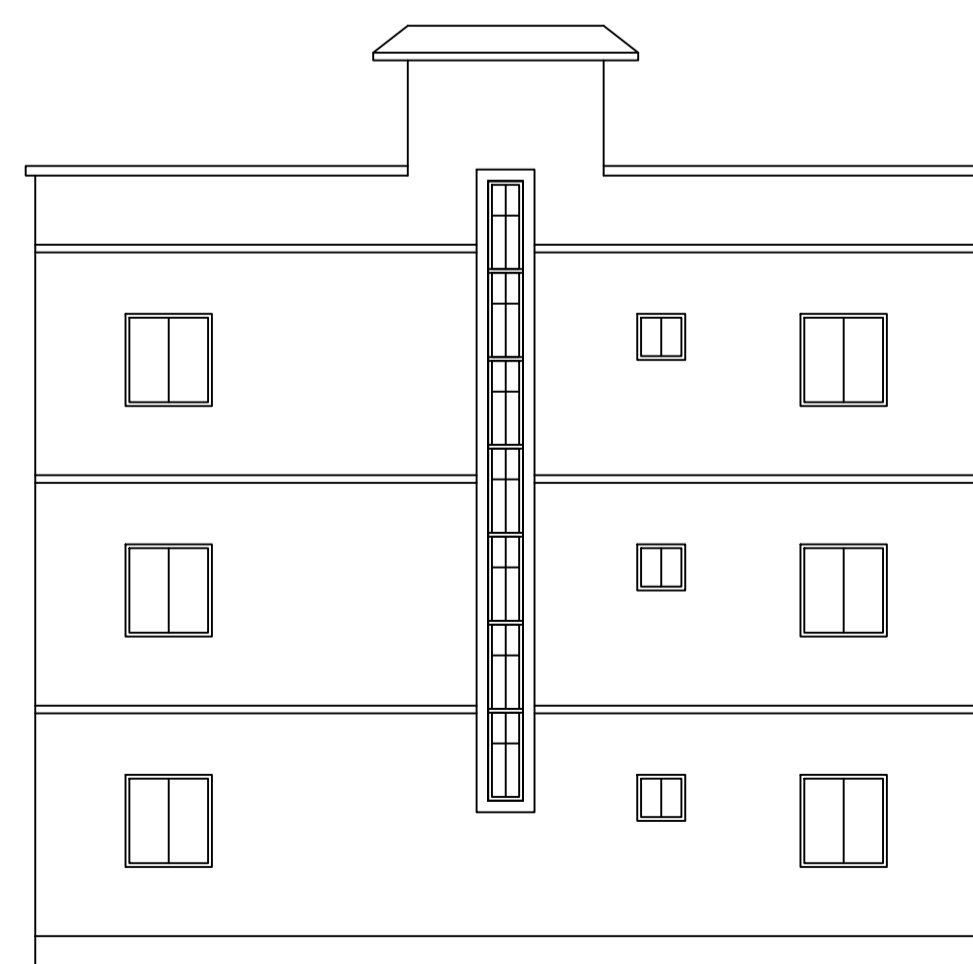

LEFT SIDE ELEVATION

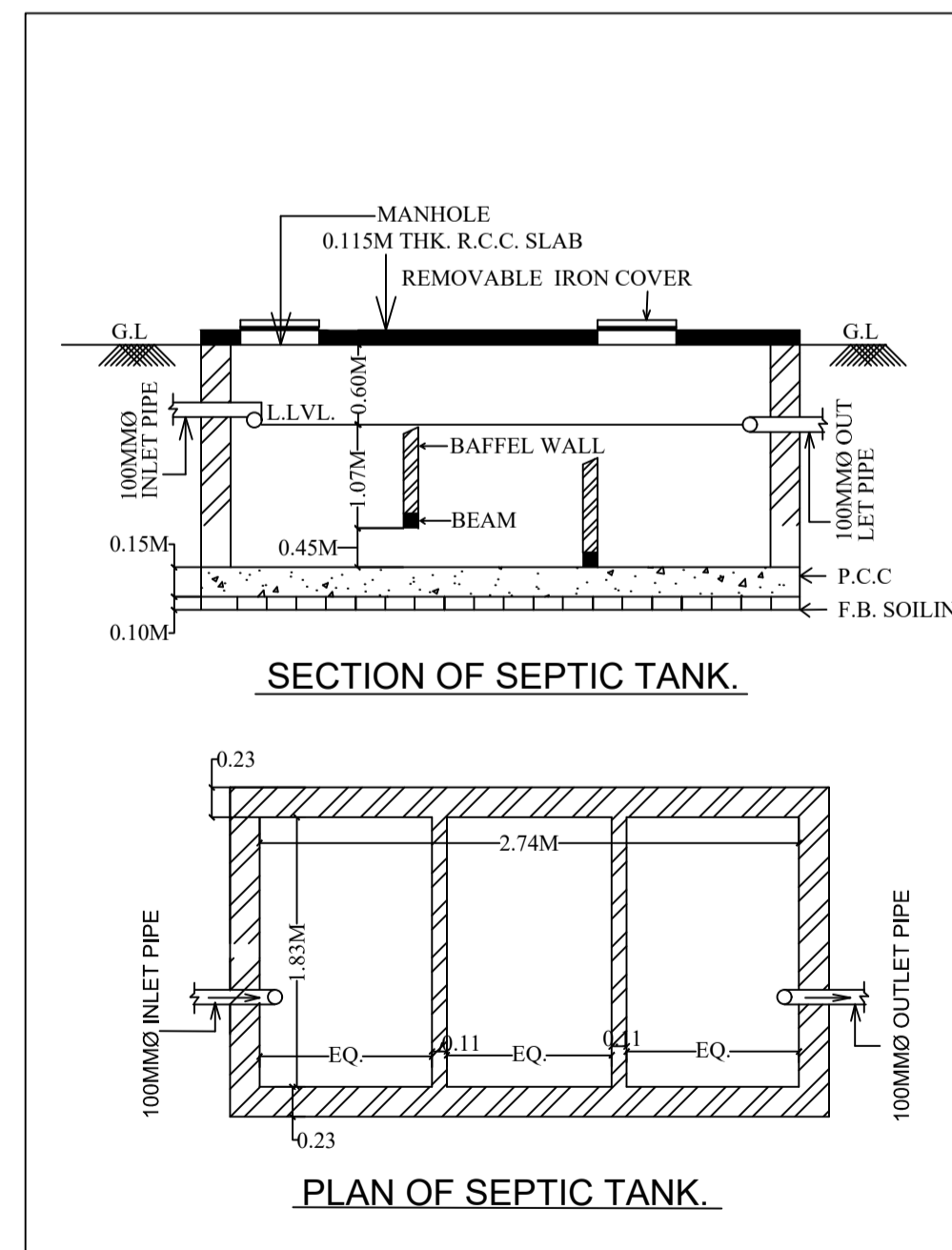

SECTION OF SEPTIC TANK.

PLAN OF SEPTIC TANK.

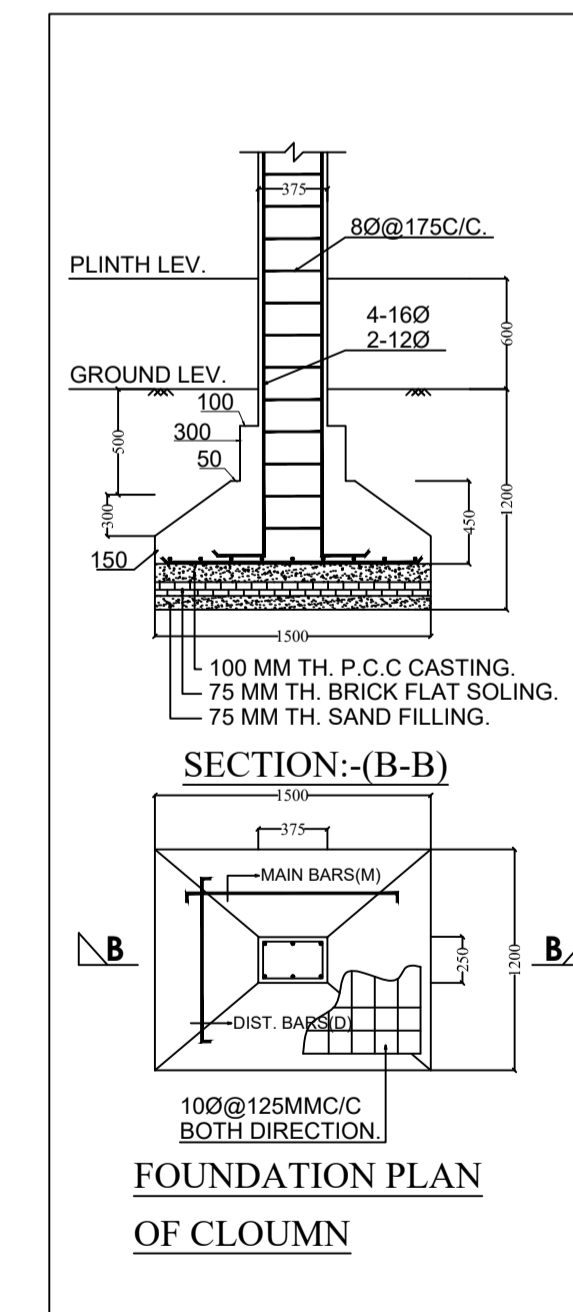

SECTION--(B-B)

FOUNDATION PLAN
OF CLOUMN

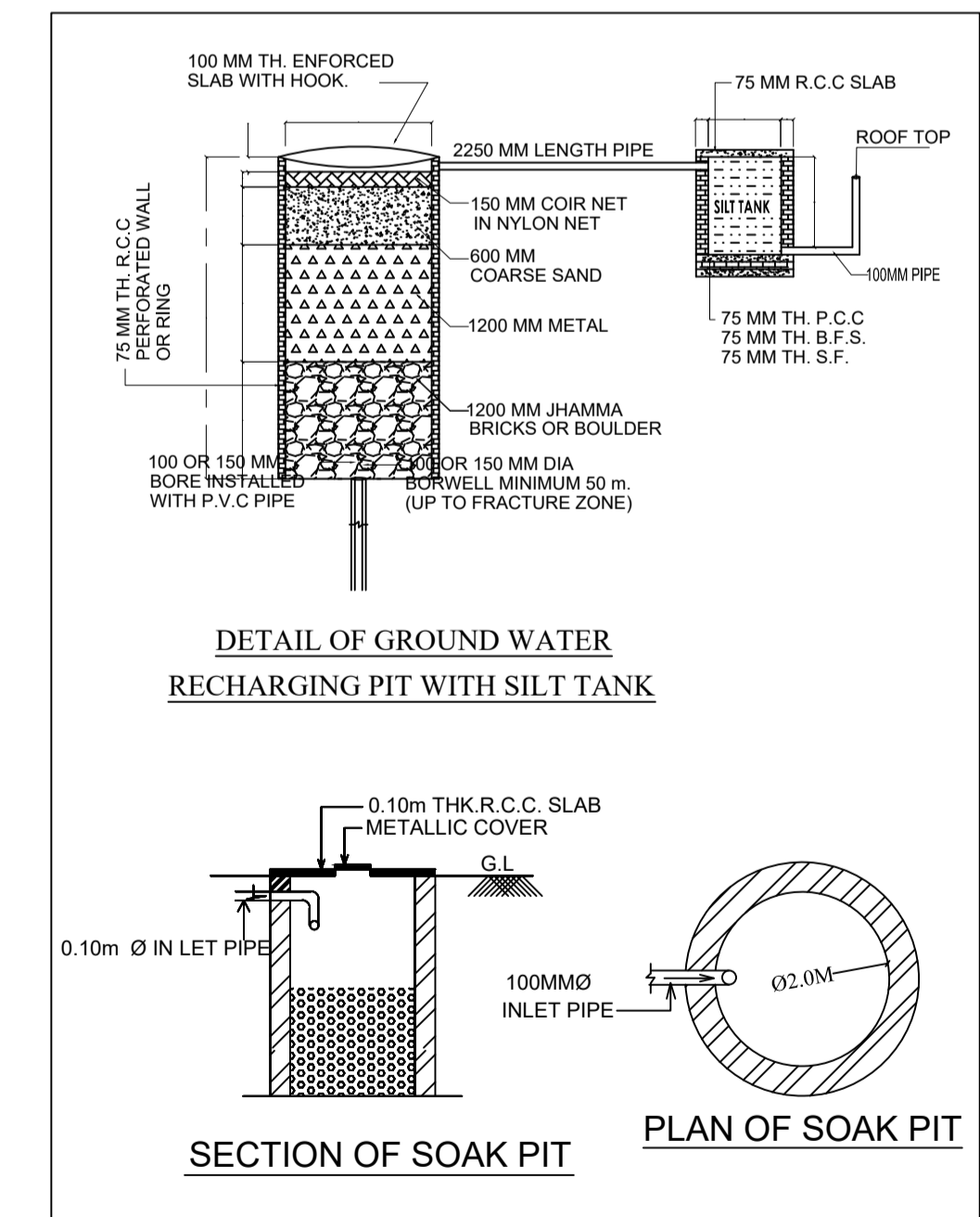

DETAIL OF GROUND WATER
RECHARGING PIT WITH SILT TANK

SECTION OF SOAK PIT

PLAN OF SOAK PIT

LTP NAME AND SIGNATURE	STRUCTURAL ENG'S NAME AND SIGNATURE	BUILDER NAME AND SIGNATURE	DIGITAL SIGNATURE
AAKASH KUMAR DMC/ENG/0019/2017			