

Proposal Basic Information

Proposal File No.	DMC/BP/0071/W21/2023
Owner Name	Sri Balistar Tiwari
Khata No	13 (NEW 13)
Plot No	894 (NEW 849)
Village Name	Dhaiya
Use	Residential
SubUse	Bungalow/ Dwelling / Non Apartment

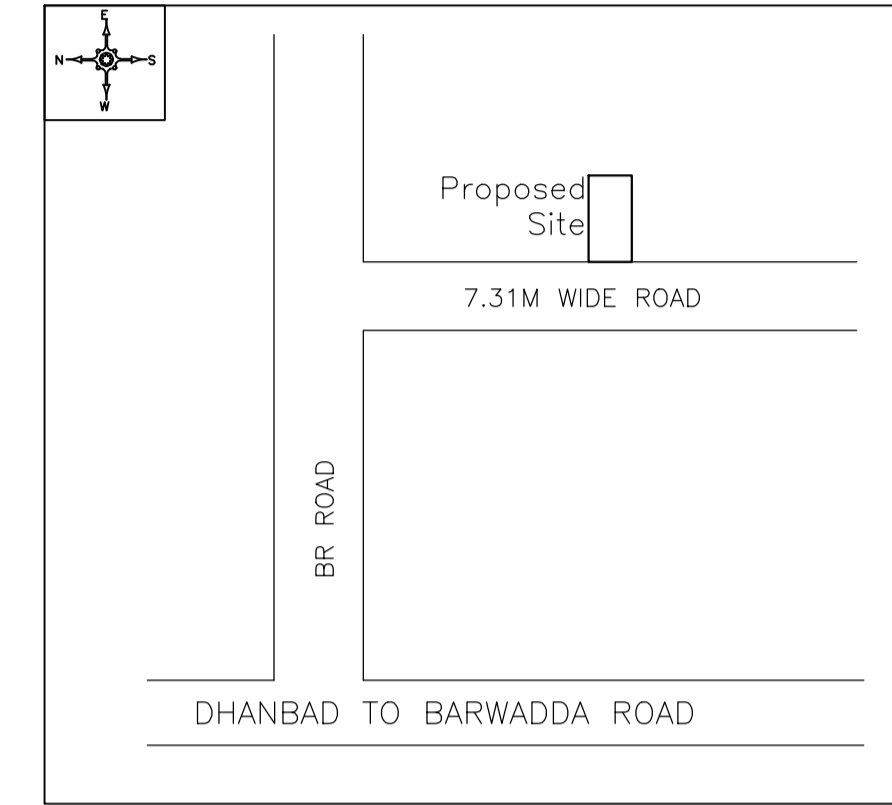

AREA STATEMENT	VERSION NO.: 1.0.65	SQ.MT.
DHANBAD MUNICIPAL CORPORATION	VERSION DATE: 16/10/2020	
PROJECT DETAIL:		
Region: DHANBAD URBAN LOCAL BODIES	Plot Use: Residential	
District: DHANBAD	Plot SubUse: Bungalow/ Dwelling / Non Apartment	
Authority: DHANBAD MUNICIPAL CORPORATION	Plot/Nearby/Religious Structure: NA	
Inward No: DMC/BP/0071/W21/2023	Plot/SubPlot No: 894 (NEW 849)	
Application Type: General Proposal	North: Plot No. - SMT. ANILA DEVI	
Project Type: Building Permission	South: Plot No. - SRI. HAREHDRA SHAW	
Nature of Development: New	East: Plot No. - SRI. ATUL MANDAL	
Location of Development Area: Old Area	West: Road Width - 4.25	
AREA DETAILS:		
AREA OF PLOT (Minimum)	(A)	157.39
Deduction for NetPlot Area		
Surrender Free of Cost		7.50
Total		7.50
NET AREA OF PLOT(Gross Plot Area - Deduction from Gross Plot Area)	(A-Deductions)	149.89
Deduction for Balance Plot Area(from Gross Plot Area)		
Surrender Free of Cost		7.50
Common Plot		23.22
Total		30.72
BALANCE AREA OF PLOT(Net Plot Area - Recreational/Amenity space)	(A-Deductions)	126.66
PLOT AREA FOR COVERAGE(Net Plot Area)	(A-Deductions)	149.89
Plot Area for FAR (Net Plot Area - Road/Widening Area)	(A-Deductions)	157.39
COVERAGE CHECK		
Permissible Coverage area (70.00 %)		104.92
Proposed Coverage Area (58.78 %)		88.11
Total Prop. Coverage Area (58.78 %)		88.11
Balance coverage area (11.21 %)		16.81
FAR CHECK		
Perm. FAR Area (1.500)		236.08
Total Perm. FAR area		236.08
Residential FAR		176.21
Proposed FAR Area		176.21
Total Proposed FAR Area		176.21
Consumed FAR (Factor)		1.12
Balance FAR Area		59.87
BUILT UP AREA CHECK		
Total Proposed BuiltUp Area		176.22
ARCHITECT (Regd)		PARTHA PAL
ENGINEER (Regd)		
SUPERVISOR (Regd)		
OWNER (Regd)		Sri Balistar Tiwari
DEVELOPMENT AUTHORITY		LOCAL BODY

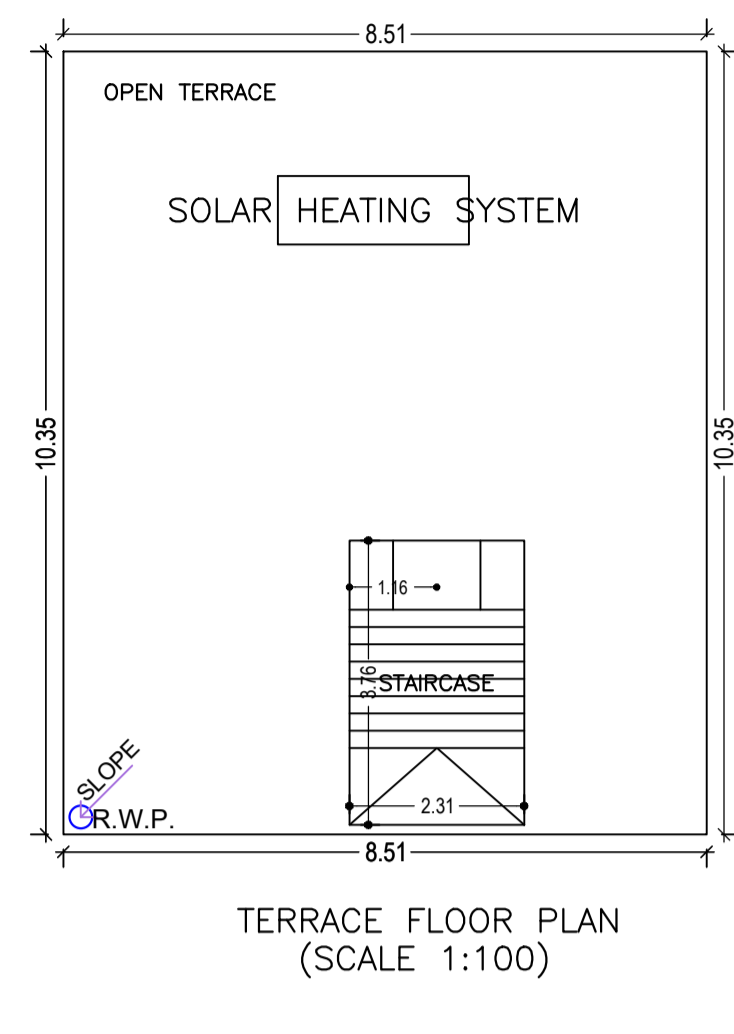
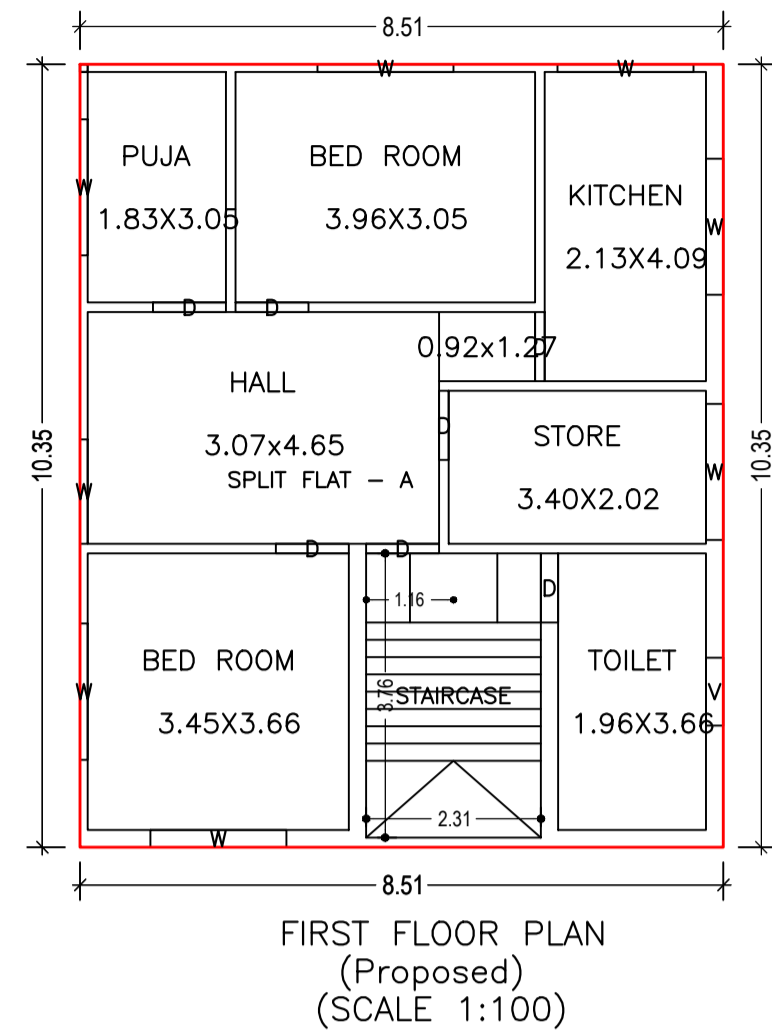
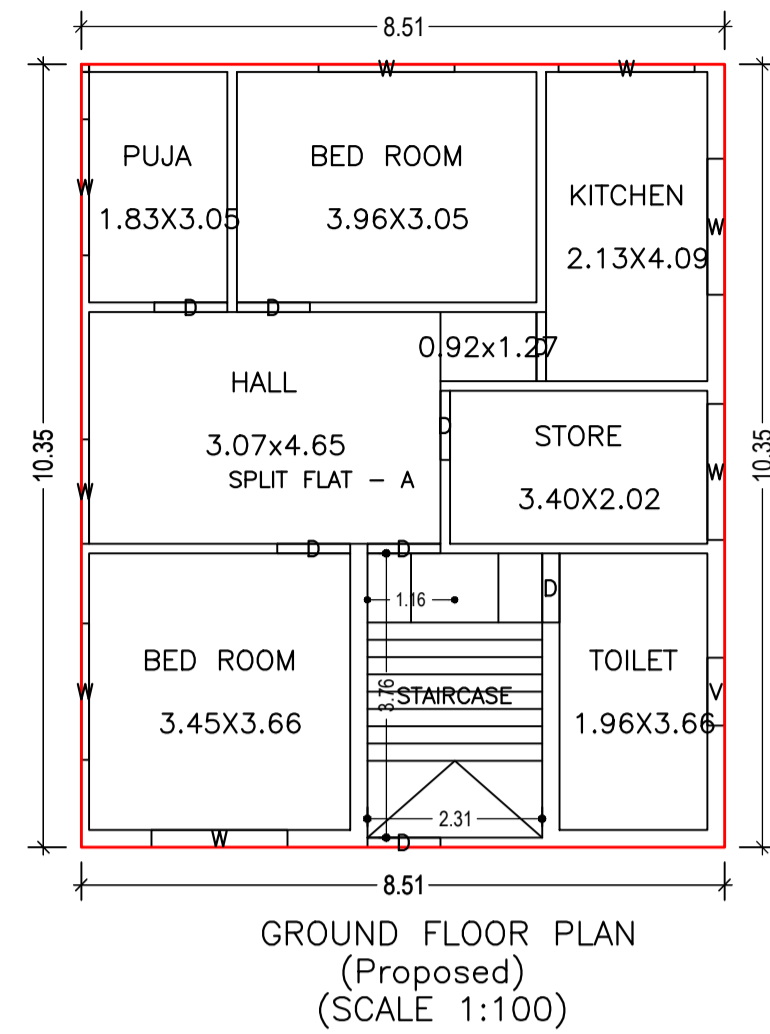
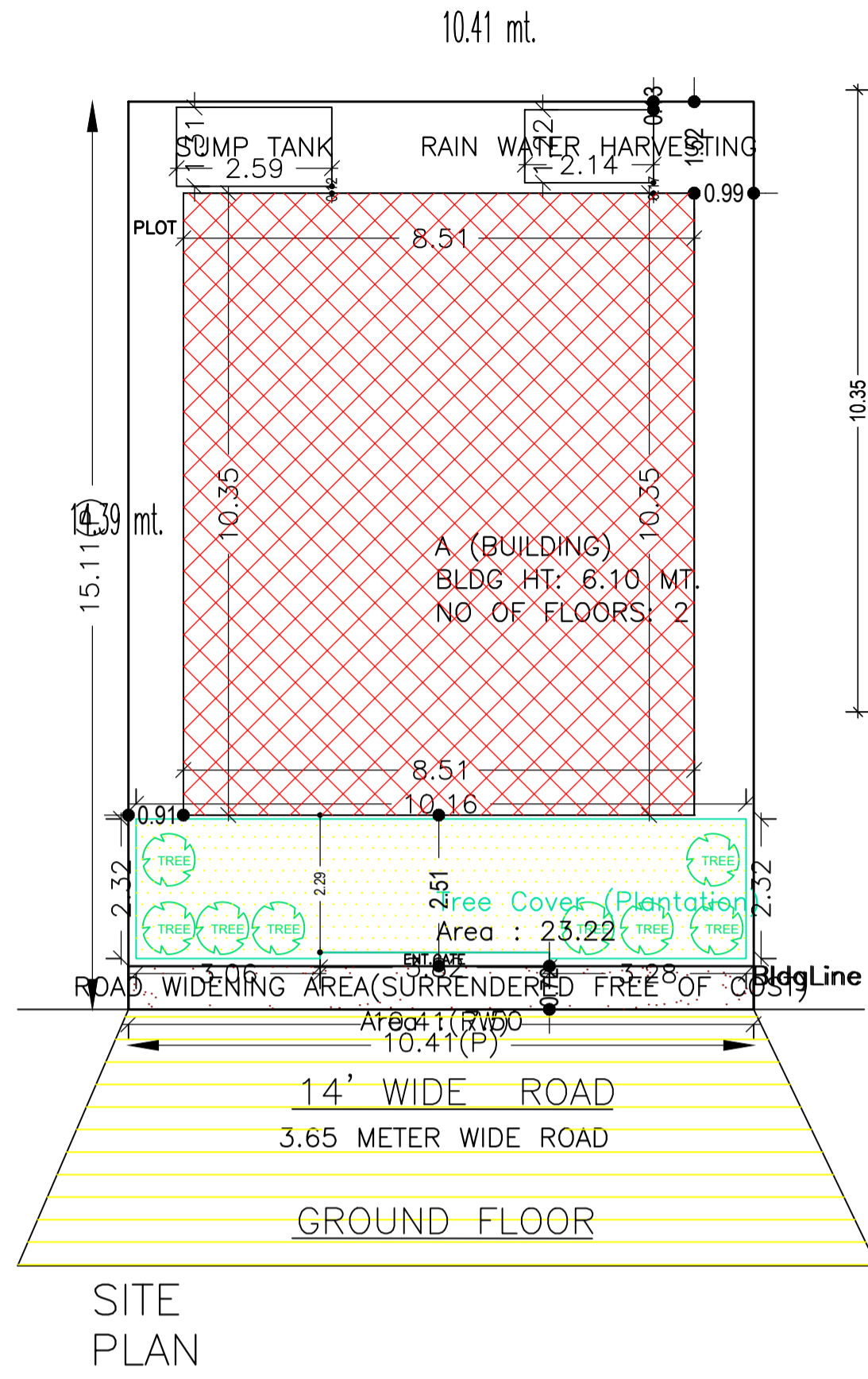
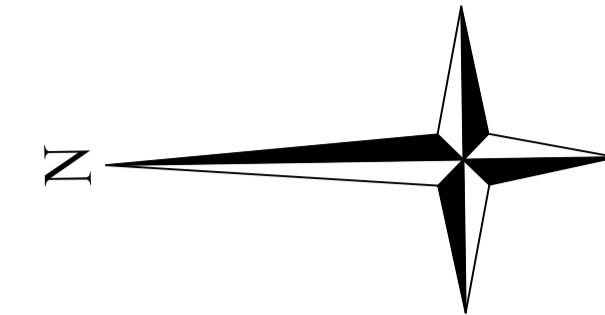
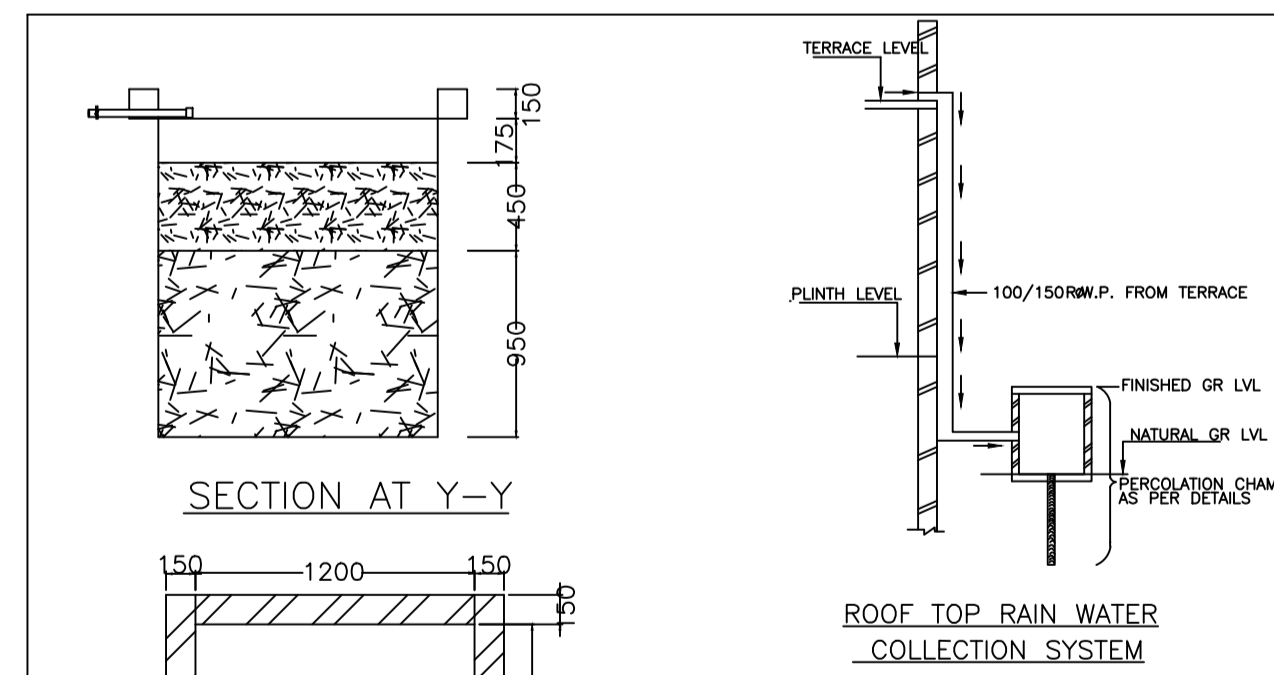
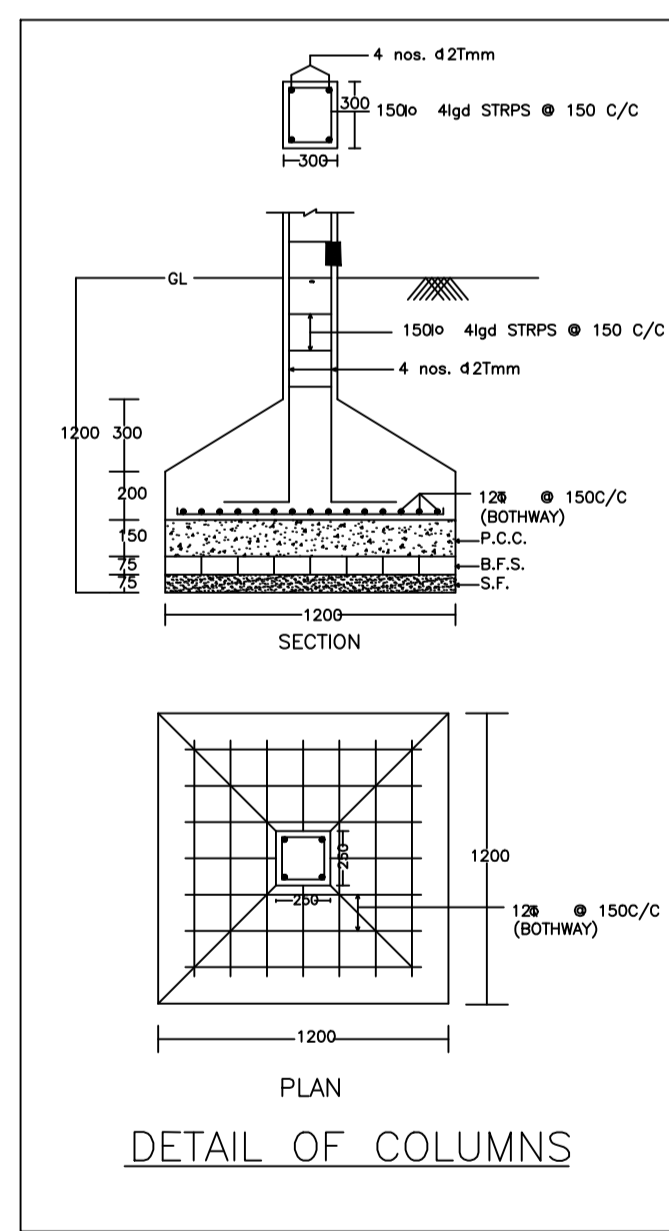
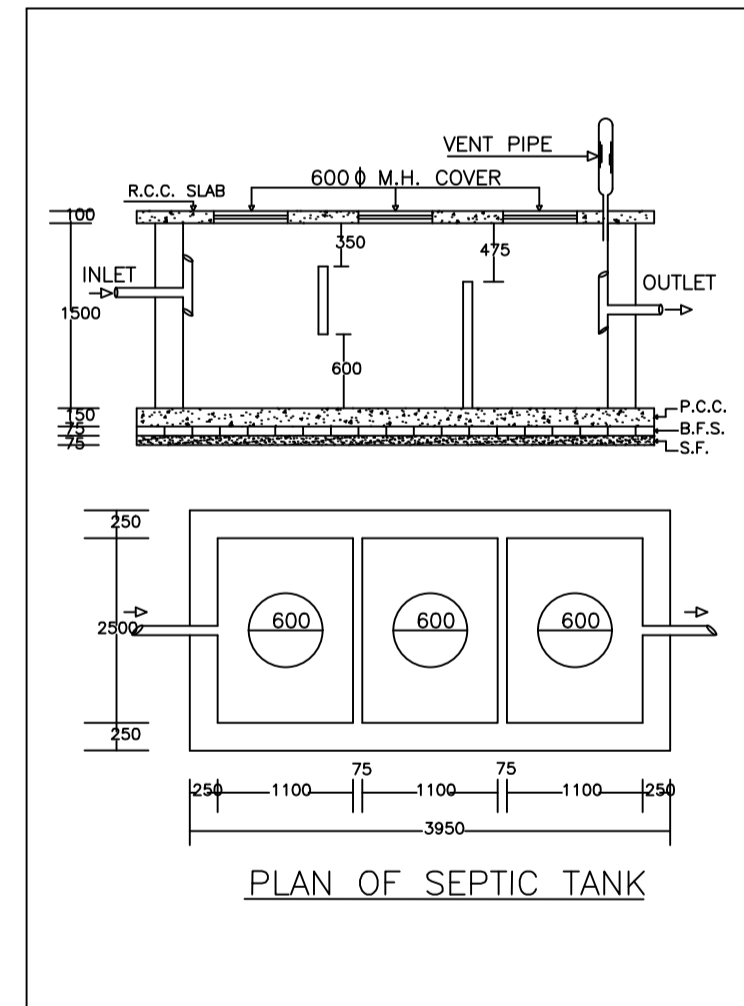
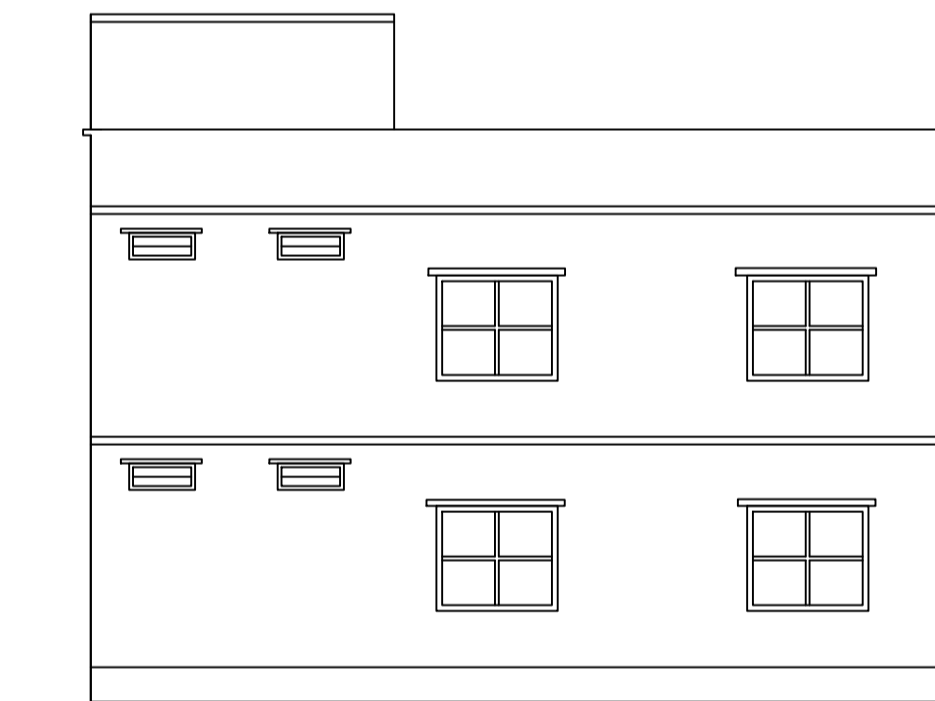

COLOR INDEX	
PLOT BOUNDARY	Black
ABUTTING ROAD	Green
PROPOSED CONSTRUCTION	Red
COMMON PLOT	Yellow
ROAD WIDENING AREA	Blue
EXISTING (To be retained)	Light Blue
EXISTING (To be demolished)	Dark Blue

Floor Name	Building Name		Total	
	Proposed Built Up Area (Sq.mt.)	Proposed FAR Area (Sq.mt.)	Total Proposed Built Up Area (Sq.mt.)	Total FAR Area (Sq.mt.)
Ground Floor	88.11	88.11	88.11	88.11
First Floor	88.11	88.11	88.11	88.11
Terrace Floor	0.00	0.00	0.00	0.00
Total :	176.22	176.22	176.22	176.22

Building Name	Building Use	Building SubUse	Building Structure
A (BUILDING)	Residential	Bungalow/ Dwelling / Non Apartment	Non-Highrise

UnitBUA Table for Building :A (BUILDING)						
FLOOR	Name	UnitBUA Type	UnitBUA Area	Carpet Area	No. of Rooms	No. of Tenement
GROUND FLOOR PLAN	SPLIT FLAT - A	FLAT	176.21	176.19	7	1
FIRST FLOOR PLAN	SPLIT FLAT - A	FLAT	0.00	0.00	7	0
Total:	-	-	176.21	176.19	14	1

Building :A (BUILDING)					
Floor Name	Total Built Up Area (Sq.mt.)	Proposed FAR Area (Sq.mt.)	Total FAR Area (Sq.mt.)	Total Consumed Additional FAR Area (Sq.mt.)	Tnmt (No.)
Ground Floor	88.11	88.11	88.11	88.11	01
First Floor	88.11	88.11	88.11	88.11	00
Terrace Floor	0.00	0.00	0.00	0.00	00
Total :	176.22	176.22	176.22	176.22	01
Total Number of Same Buildings	1				
Total:	176.22	176.22	176.22	176.22	01

SCHEDULE OF DOOR:

BUILDING NAME	NAME	LENGTH	HEIGHT	NOS
A (BUILDING)	D	0.91	2.10	06
A (BUILDING)	D	0.97	2.10	08

SCHEDULE OF WINDOW/VENTILATION:

BUILDING NAME	NAME	LENGTH	HEIGHT	NOS
A (BUILDING)	V	0.90	1.20	02
A (BUILDING)	W	1.38	1.20	02
A (BUILDING)	W	1.80	1.20	14

FAR & Tenement Details (Table 4c-1)

Building	No. of Same Bldg	Total Built Up Area (Sq.mt.)	Proposed FAR Area (Sq.mt.)	Total FAR Area (Sq.mt.)	Total Consumed Additional FAR Area (Sq.mt.)	Tnmt (No.)
A (BUILDING)	1	176.22	176.22	176.22	176.22	01
Grand Total :	1	176.22	176.22	176.22	176.22	01

LTP NAME AND SIGNATURE	STRUCTURAL ENG'S NAME AND SIGNATURE	BUILDER NAME AND SIGNATURE	DIGITAL SIGNATURE
PARTHA PAL DMC/ENG/0021/2016			