

Proposal Basic Information	
Proposal File No.	DMC/BP/0073/W22/2023
Owner Name	SMT. PUSHPA TEWARI
Khata No	90 (NEW : 47)
Plot No	1375 (NEW : 1751)
Village Name	Bhelaland
Use	Residential
SubUse	Bungalow/ Dwelling / Non Apartment

AREA STATEMENT		VERSION NO. : 1.0.66
DHANBAD MUNICIPAL CORPORATION		VERSION DATE: 16/10/2020
PROJECT DETAIL:		
Region: JHARKHAND URBAN LOCAL BODIES	Plot Use: Residential	
District: DHANBAD	Plot SubUse: Bungalow/ Dwelling / Non Apartment	
Authority: DHANBAD MUNICIPAL CORPORATION	PlotNearby/ReligiousStructure: NA	
Inward No: DMC/BP/0073/W22/2023	PlotSubPlot No: 1375 (NEW : 1751)	
Application Type: General Proposal	North: Plot No. - KALAWATI DEVI	
Project Type: Building Permission	South: Plot No. - SARITA OJHA	
Nature of Development: New	East: Plot No. - LAL MAHATO	
Location of Development Area: Old Area	West: Road Width - 3.65	

AREA DETAILS:		SQ.MT.
AREA OF PLOT (Minimum)	(A)	114.73
Deduction for NetPlot Area		
Surrender Free of Cost		11.19
Total		11.19
NET AREA OF PLOT(Gross Plot Area - Deduction from Gross Plot area)	(A-Deductions)	103.54
Deduction for Balance Plot Area(from Gross Plot Area)		
Surrender Free of Cost		11.19
Common Plot		6.92
Total		18.11
BALANCE AREA OF PLOT(Net Plot Area - Recreational/Amenity space)	(A-Deductions)	96.62
PLOT AREA FOR COVERAGE(Net Plot Area)	(A-Deductions)	103.54
Plot Area for FAR (Net Plot Area + RoadWidening Area)	(A-Deductions)	114.73

COVERAGE CHECK		
Permissible Coverage area (70.00 %)		72.48
Proposed Coverage Area (53.54 %)		55.43
Total Prop. Coverage Area (53.54 %)		55.43
Balance coverage area (16.47 %)		17.05

FAR CHECK		
Perm. FAR Area (1.500)		172.10
Total Perm. FAR area		172.10
Residential FAR		110.86
Proposed FAR Area		110.86
Total Proposed FAR Area		110.86
Consumed FAR (Factor)		0.97
Balance FAR Area		61.24

BUILT UP AREA CHECK		
Total Proposed BuiltUp Area		110.86

ARCHITECT (Regd)		PARTHA PAL
ENGINEER (Regd)		
SUPERVISOR (Regd)		
OWNER (Regd)		SMT. PUSHPA TEWARI
DEVELOPMENT AUTHORITY		LOCAL BODY

COLOR INDEX	
PLOT BOUNDARY	[Red Line]
ABUTTING ROAD	[Green Line]
PROPOSED CONSTRUCTION	[Yellow Line]
COMMON PLOT	[Blue Line]
ROAD WIDENING AREA	[Orange Line]
EXISTING (To be retained)	[Grey Line]
EXISTING (To be demolished)	[Black Line]

Buildingwise Floor FAR Details				
Floor Name	Building Name A (1)		Total	
	Proposed Built Up Area (Sq.mt.)	Proposed FAR Area (Sq.mt.)	Total Proposed Built Up Area (Sq.mt.)	Total FAR Area (Sq.mt.)
Ground Floor	55.43	55.43	55.43	55.43
First Floor	55.43	55.43	55.43	55.43
Terrace Floor	0.00	0.00	0.00	0.00
Total:	110.86	110.86	110.86	110.86

Building USE/SUBUSE Details				
Building Name	Building Use	Building SubUse	Building Structure	
A (1)	Residential	Bungalow/ Dwelling / Non Apartment	Non-Highrise	

SCHEDULE OF DOOR:				
BUILDING NAME	NAME	LENGTH	HEIGHT	NOS
A (1)	d3	0.76	2.10	02
A (1)	d2	0.91	2.10	01
A (1)	d1	1.07	2.10	06

SCHEDULE OF WINDOW/VENTILATION:				
BUILDING NAME	NAME	LENGTH	HEIGHT	NOS
A (1)	w1	1.72	1.20	01
A (1)	w1	1.80	1.20	09
A (1)	v	1.91	0.45	01
A (1)	v	1.99	0.45	01

UnitBUA Table for Building :A (1)

FLOOR	Name	UnitBUA Type	UnitBUA Area	Carpet Area	No. of Rooms	No. of Tenement
GROUND FLOOR PLAN	SPLIT 1	FLAT	110.86	110.75	4	1
FIRST FLOOR PLAN	SPLIT 1	FLAT	0.00	0.00	4	0
Total:	-	-	110.86	110.75	8	1

FAR & Tenement Details (Table 4c-1)

Building	No. of Same Bldg	Total Built Up Area (Sq.mt.)	Proposed FAR Area (Sq.mt.)	Total FAR Area (Sq.mt.)	Total Consumed Additional FAR Area (Sq.mt.)	Tnmt (No.)
A (1)	1	110.86	110.86	110.86	110.86	01
Grand Total:	1	110.86	110.86	110.86	110.86	01

Building :A (1)

Floor Name	Total Built Up Area (Sq.mt.)	Proposed FAR Area (Sq.mt.)	Total FAR Area (Sq.mt.)	Total Consumed Additional FAR Area (Sq.mt.)	Tnmt (No.)
Ground Floor	55.43	55.43	55.43	55.43	01
First Floor	55.43	55.43	55.43	55.43	00
Terrace Floor	0.00	0.00	0.00	0.00	00
Total:	110.86	110.86	110.86	110.86	01
Total Number of Same Buildings	1				
Total:	110.86	110.86	110.86	110.86	01

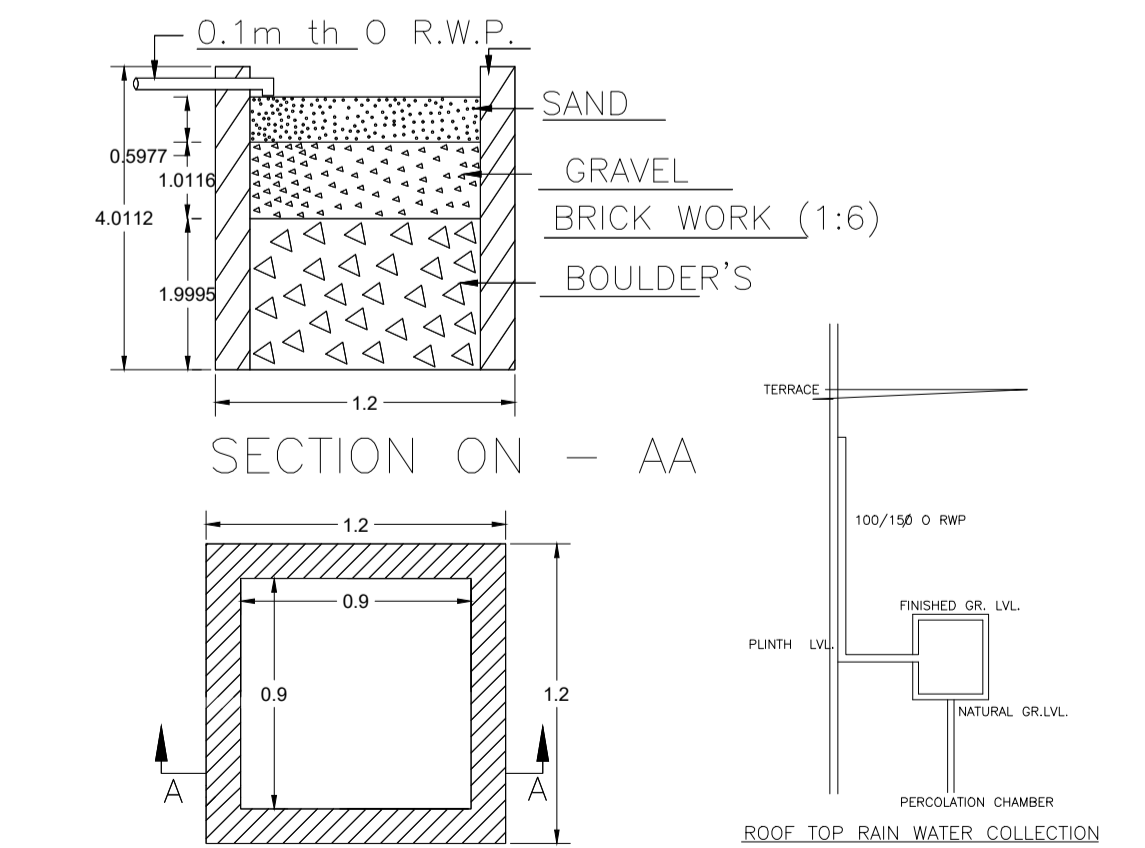
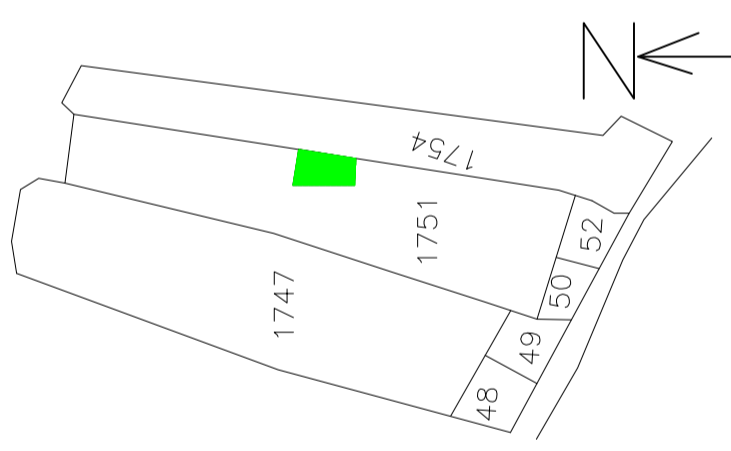
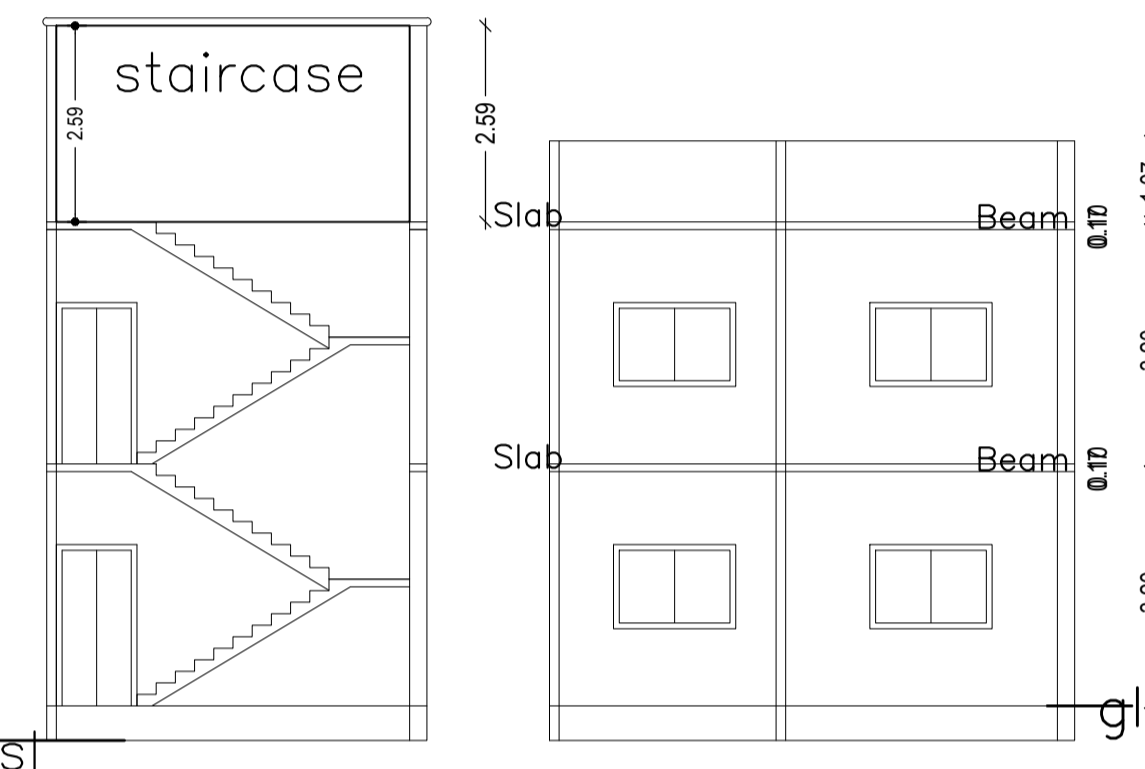

DETAIL'S OF WATER HARVESTING

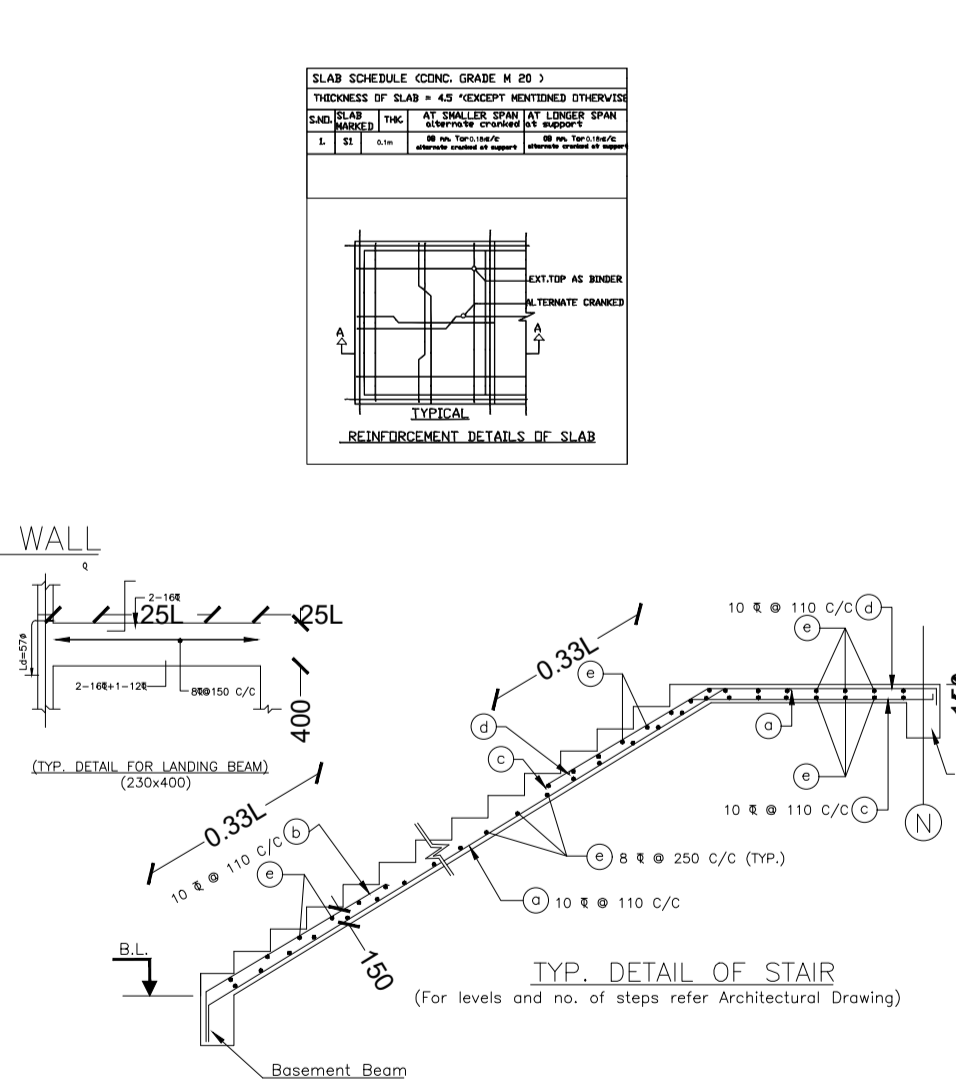
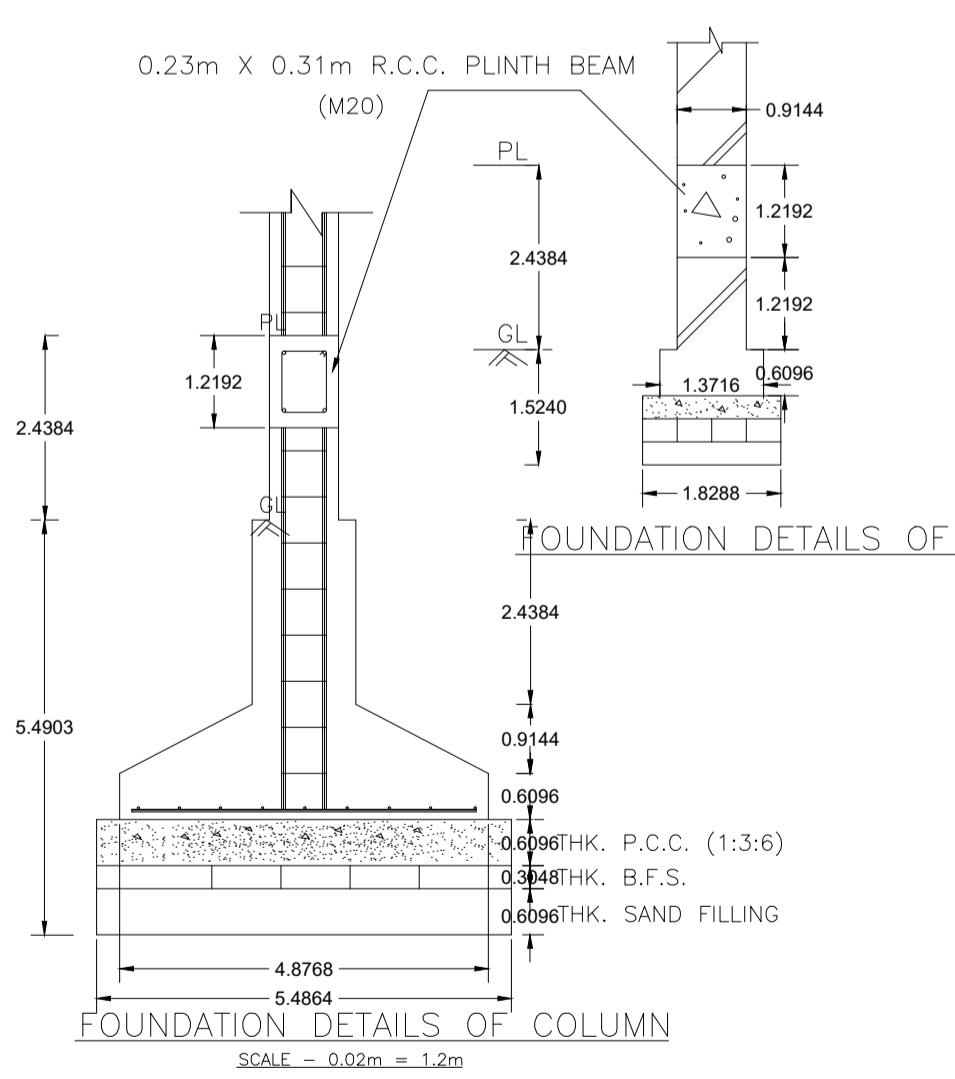

TYP. DETAIL OF STAIR

DETAILS OF SEPTIC TANK

FOUNDATION DETAILS OF WALL

FOUNDATION DETAILS OF COLUMN

REINFORCEMENT DETAILS OF SLAB

REINFORCEMENT DETAILS OF SLAB

REINFORCEMENT DETAILS OF SLAB

REINFORCEMENT DETAILS OF SLAB

REINFORCEMENT DETAILS OF SLAB

REINFORCEMENT DETAILS OF SLAB

REINFORCEMENT DETAILS OF SLAB

LTP NAME AND SIGNATURE	STRUCTURAL ENG'S NAME AND SIGNATURE	BUILDER NAME AND SIGNATURE	DIGITAL SIGNATURE
PARTHA PAL DMC/ENG/0021/2016			