

LOCATION PLAN

SCHEDULE OF DOOR:

BUILDING NAME	NAME	LENGTH	HEIGHT	NOS
A (ASHA RAY)	D	0.76	2.10	05
A (ASHA RAY)	D	0.91	2.10	04
A (ASHA RAY)	D	1.03	2.10	02
A (ASHA RAY)	D	3.95	2.10	01

SCHEDULE OF WINDOW/VENTILATION:

BUILDING NAME	NAME	LENGTH	HEIGHT	NOS
A (ASHA RAY)	W	0.99	1.20	01
A (ASHA RAY)	W	1.06	1.20	01
A (ASHA RAY)	W	1.22	1.20	01
A (ASHA RAY)	W	1.78	1.20	01
A (ASHA RAY)	W	1.91	1.20	01
A (ASHA RAY)	W	2.00	1.20	01
A (ASHA RAY)	W	2.06	1.20	01
A (ASHA RAY)	W	2.11	1.20	01
A (ASHA RAY)	W	2.24	1.20	01
A (ASHA RAY)	W	2.27	1.20	01
A (ASHA RAY)	W	2.30	1.20	01
A (ASHA RAY)	W	2.35	1.20	01
A (ASHA RAY)	W	2.52	1.20	01
A (ASHA RAY)	W	2.55	1.20	01
A (ASHA RAY)	W	2.57	1.20	01
A (ASHA RAY)	W	2.58	1.20	01
A (ASHA RAY)	W	2.68	1.20	01
A (ASHA RAY)	W	2.75	1.20	01
A (ASHA RAY)	W	2.84	1.20	01
A (ASHA RAY)	W	2.90	1.20	01
A (ASHA RAY)	W	2.94	1.20	02

UnitBUA Table for Building :A (ASHA RAY)

FLOOR	Name	UnitBUA Type	UnitBUA Area	Carpet Area	No. of Rooms	No. of Tenement
FIRST FLOOR PLAN	SPLIT A	FLAT	0.00	0.00	7	0
GROUND FLOOR PLAN	SPLIT A	FLAT	201.23	201.13	3	1
Total:	-	-	201.23	201.13	10	1

FAR & Tenement Details (Table 4c-1)

Building	No. of Same Bldg	Total Built Up Area (Sq.mt.)	Proposed FAR Area (Sq.mt.) Resi.	Total FAR Area (Sq.mt.)	Total Consumed Additional FAR Area (Sq.mt.)	Trmt (No.)
A (ASHA RAY)	1	201.22	201.22	201.22	201.22	01
Grand Total :	1	201.22	201.22	201.22	201.22	01

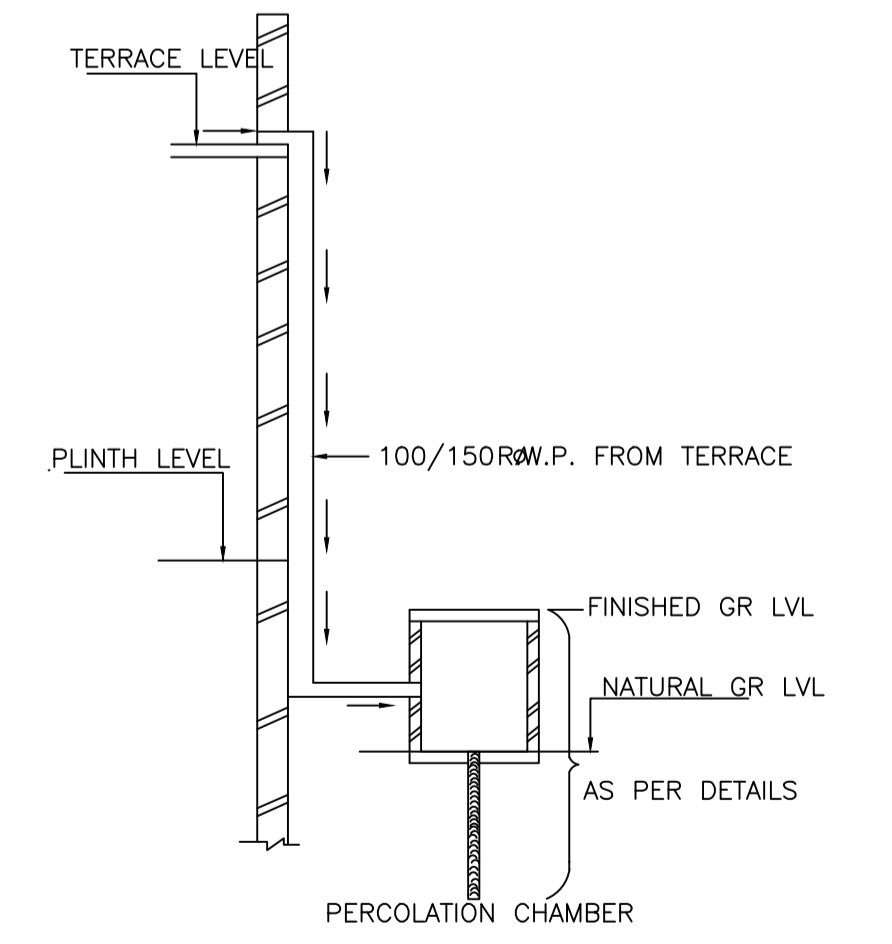
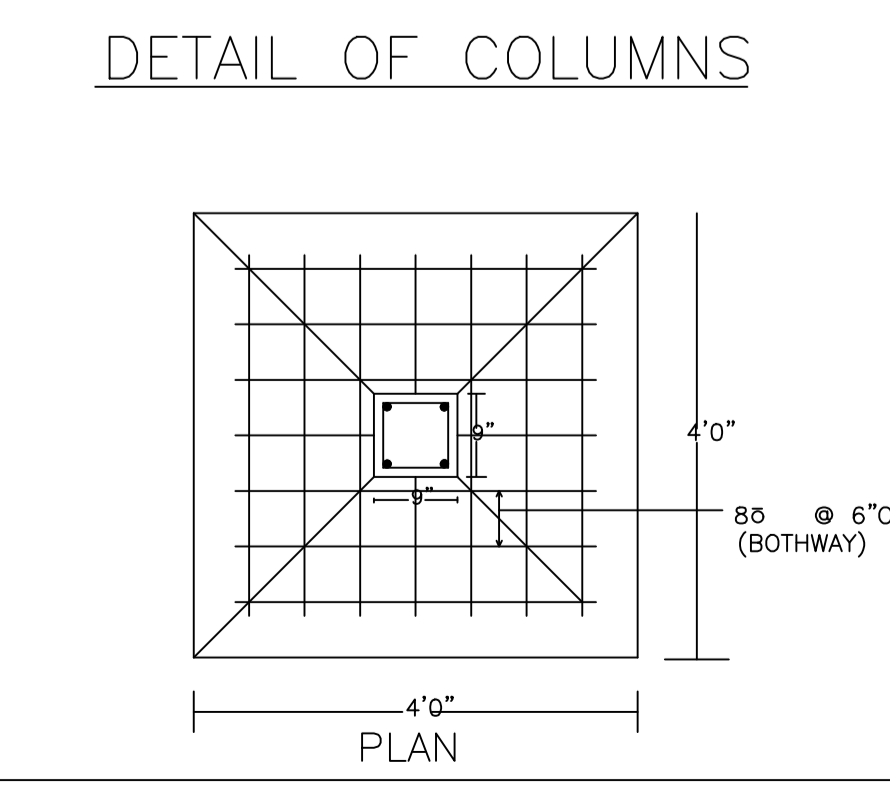
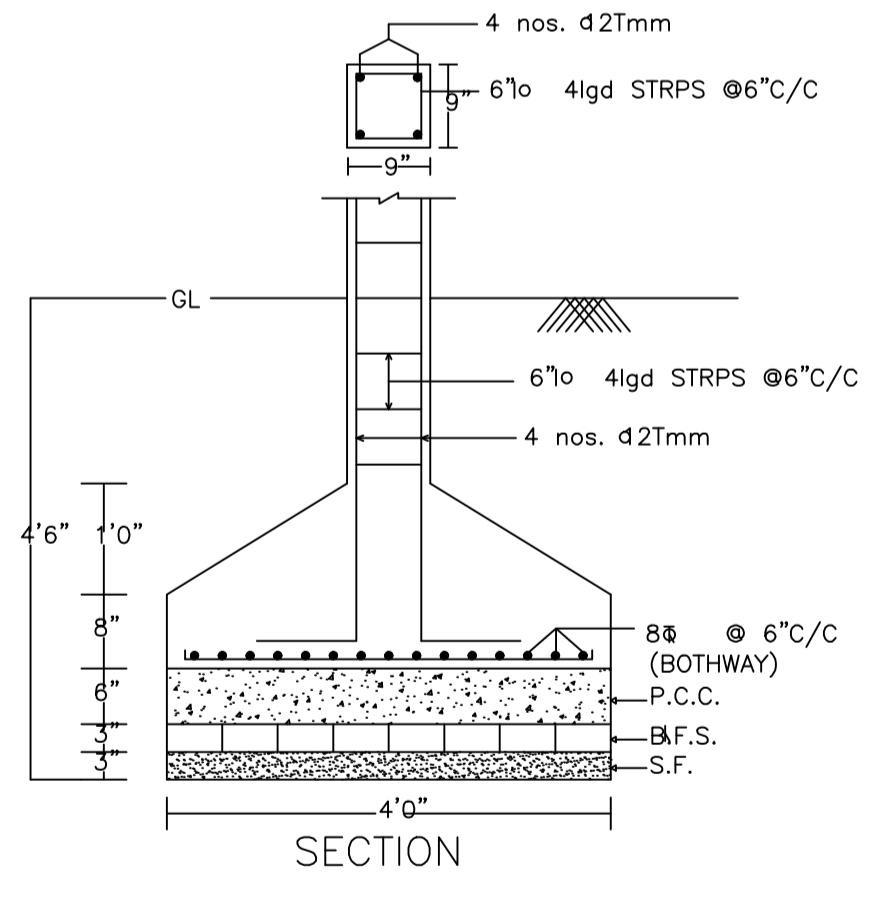
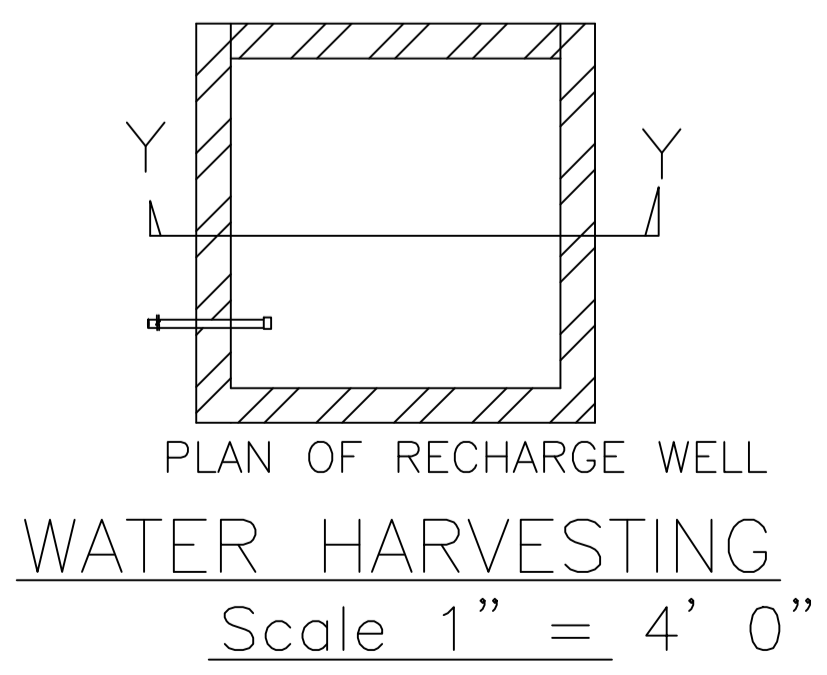
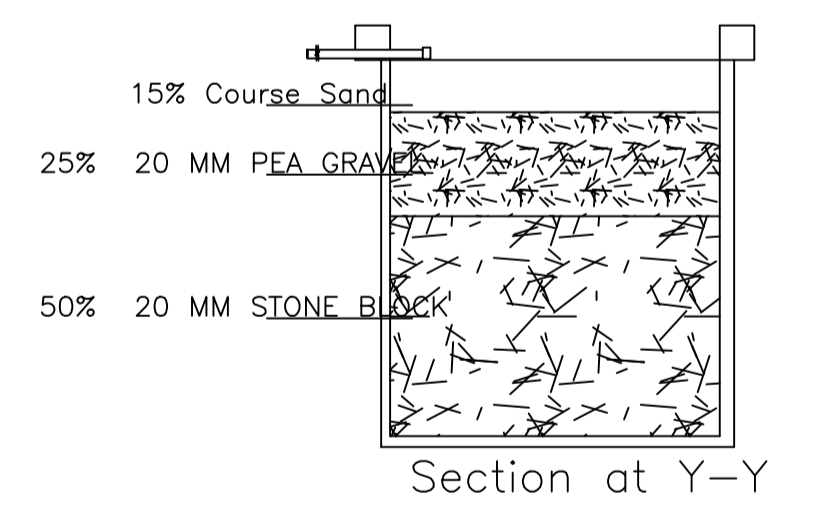

Proposal Basic Information

Proposal File No.	DMC/BP/0181/W23/2023
Owner Name	ASHA RAY
Khata No	OLD-122, NEW-388
Plot No	OLD-1206(P), NEW-1732
Village Name	Kolakusma
Use	Residential
SubUse	Bungalow/ Dwelling / Non Apartment

AREA STATEMENT

AREA DETAILS:		SQ.MT.
AREA OF PLOT (Minimum)	(A)	165.53
NET AREA OF PLOT(Gross Plot Area - Deduction from Gross Plot area)	(A-Deductions)	165.53
Deduction for Balance Plot Area(from Gross Plot Area)		
Common Plot		22.61
Total		22.61
BALANCE AREA OF PLOT(Net Plot Area - Recreational/Amenity space)	(A-Deductions)	142.92
PLOT AREA FOR COVERAGE(Net Plot Area)	(A-Deductions)	165.53
Plot Area for FAR (Net Plot Area + RoadWidening Area)	(A-Deductions)	165.53
COVERAGE CHECK		
Permissible Coverage area (70.00 %)		115.87
Proposed Coverage Area (60.78 %)		100.61
Total Prop. Coverage Area (60.78 %)		100.61
Balance coverage area (9.22 %)		15.26
FAR CHECK		
Perm. FAR Area (2.500)		413.83
Total Perm. FAR area		413.83
Residential FAR		201.23
Proposed FAR Area		201.23
Total Proposed FAR Area		201.23
Consumed FAR (Factor)		1.22
Balance FAR Area		212.60
BUILT UP AREA CHECK		
Total Proposed BuiltUp Area		201.22
ARCHITECT (Regd)		
RAJEEV RANJAN SINGH		
ENGINEER (Regd)		
SUPERVISOR (Regd)		
OWNER (Regd)		
ASHA RAY		
DEVELOPMENT AUTHORITY		
LOCAL BODY		

COLOR INDEX

PLOT BOUNDARY	Black
ABUTTING ROAD	Green
PROPOSED CONSTRUCTION	Red
COMMON PLOT	Yellow
ROAD WIDENING AREA	Blue
EXISTING (To be retained)	Orange
EXISTING (To be demolished)	Grey

Buildingwise Floor FAR Details

Floor Name	Building Name		Total	
	Proposed Built Up Area (Sq.mt.)	Proposed FAR Area (Sq.mt.)	Total Proposed Built Up Area (Sq.mt.)	Total FAR Area (Sq.mt.)
Ground Floor	100.61	100.61	100.61	100.61
First Floor	100.61	100.61	100.61	100.61
Terrace Floor	0.00	0.00	0.00	0.00
Total :	201.22	201.22	201.22	201.22

Building USE/SUBUSE Details

Building Name	Building Use	Building SubUse	Building Structure
A (ASHA RAY)	Residential	Bungalow/ Dwelling / Non Apartment	Non-Highrise

Building :A (ASHA RAY)

Floor Name	Total Built Up Area (Sq.mt.)	Proposed FAR Area (Sq.mt.) Resi.	Total FAR Area (Sq.mt.)	Total Consumed Additional FAR Area (Sq.mt.)	Trmt (No.)
Ground Floor	100.61	100.61	100.61	100.61	01
First Floor	100.61	100.61	100.61	100.61	00
Terrace Floor	0.00	0.00	0.00	0.00	00
Total :	201.22	201.22	201.22	201.22	01
Total Number of Same Buildings :	1				
Total :	201.22	201.22	201.22	201.22	01

LTP NAME AND SIGNATURE	STRUCTURAL ENG'S NAME AND SIGNATURE	BUILDER NAME AND SIGNATURE	DIGITAL SIGNATURE
RAJEEV RANJAN SINGH DMC/ENG/0032/2017			

Proposal Basic Information	
Proposal File No.	DMC/BP/0181/W23/2023
Owner Name	ASHA RAY
Khata No	OLD-122, NEW-388
Plot No	OLD-1206(P), NEW-1732
Village Name	Kolakusma
Use	Residential
SubUse	Bungalow/ Dwelling / Non Apartment

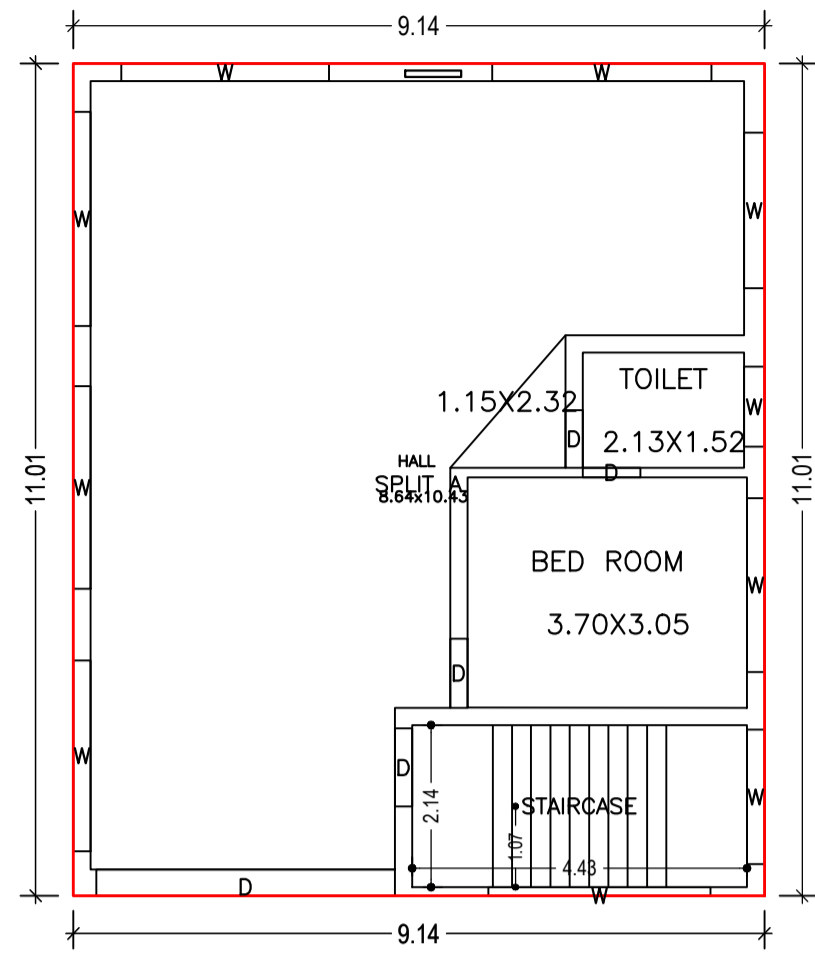

GROUND FLOOR PLAN
(Proposed)
(SCALE 1:100)

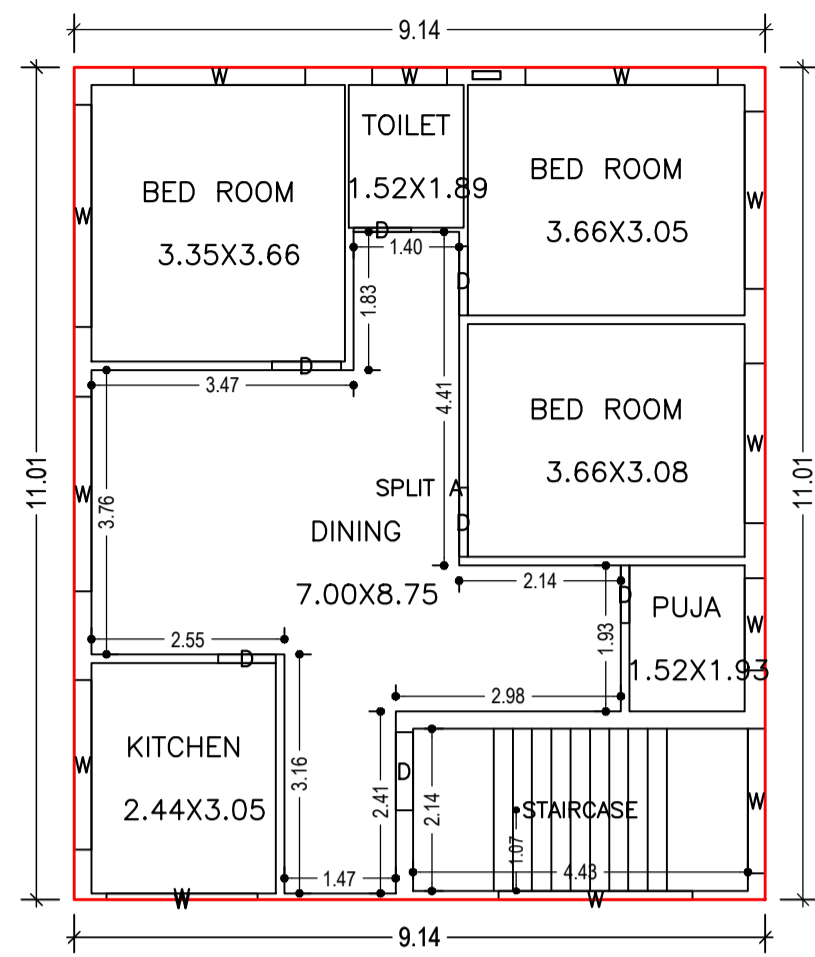

FIRST FLOOR PLAN
(Proposed)
(SCALE 1:100)

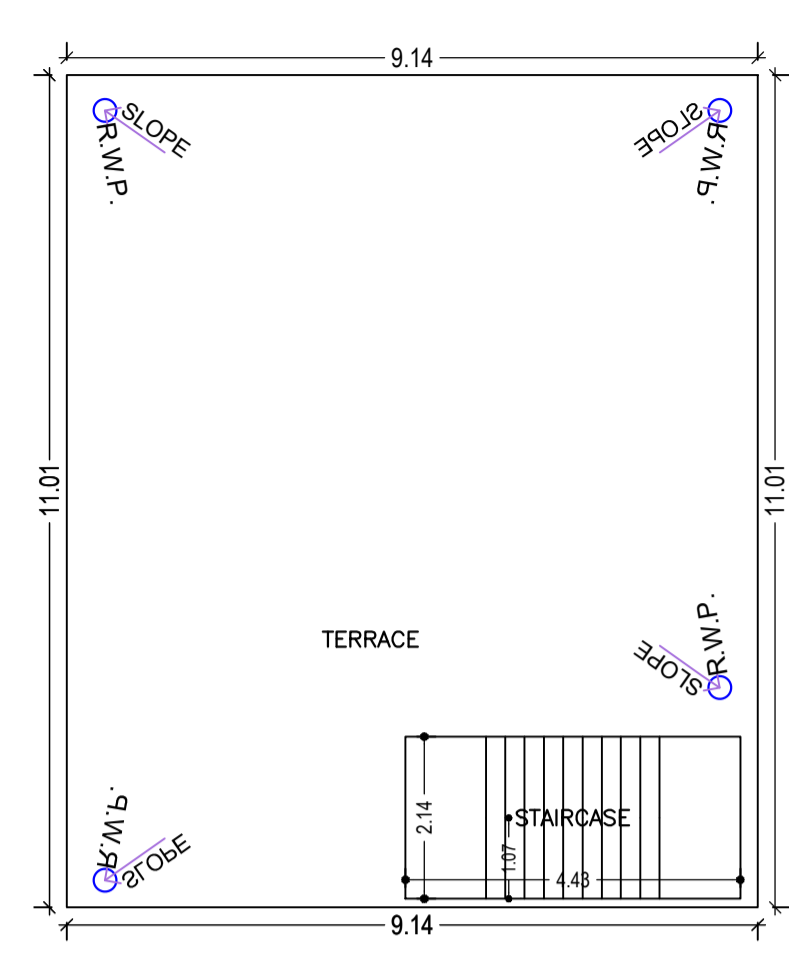

TERRACE FLOOR PLAN
(SCALE 1:100)

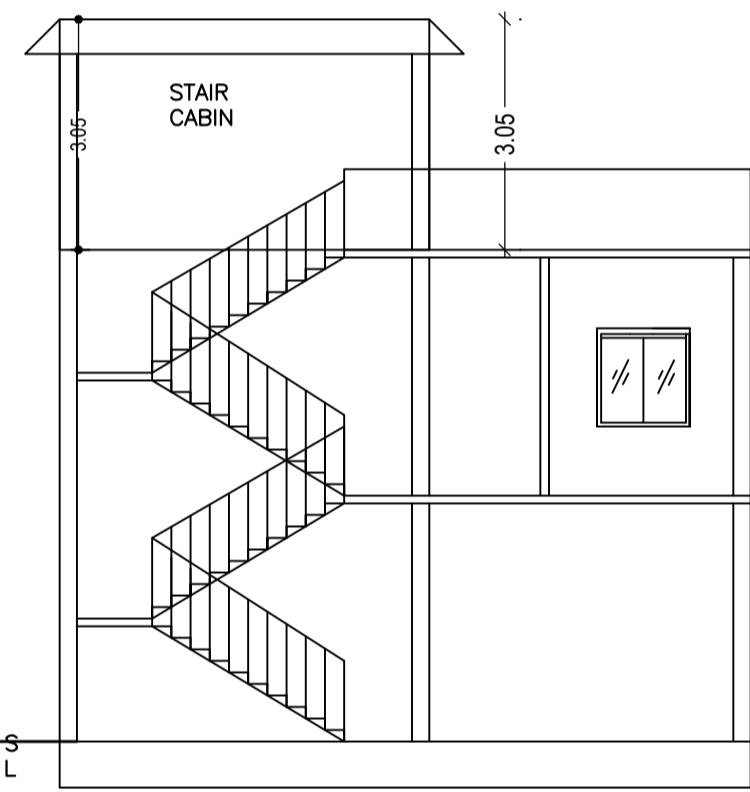

SECTION ON XX

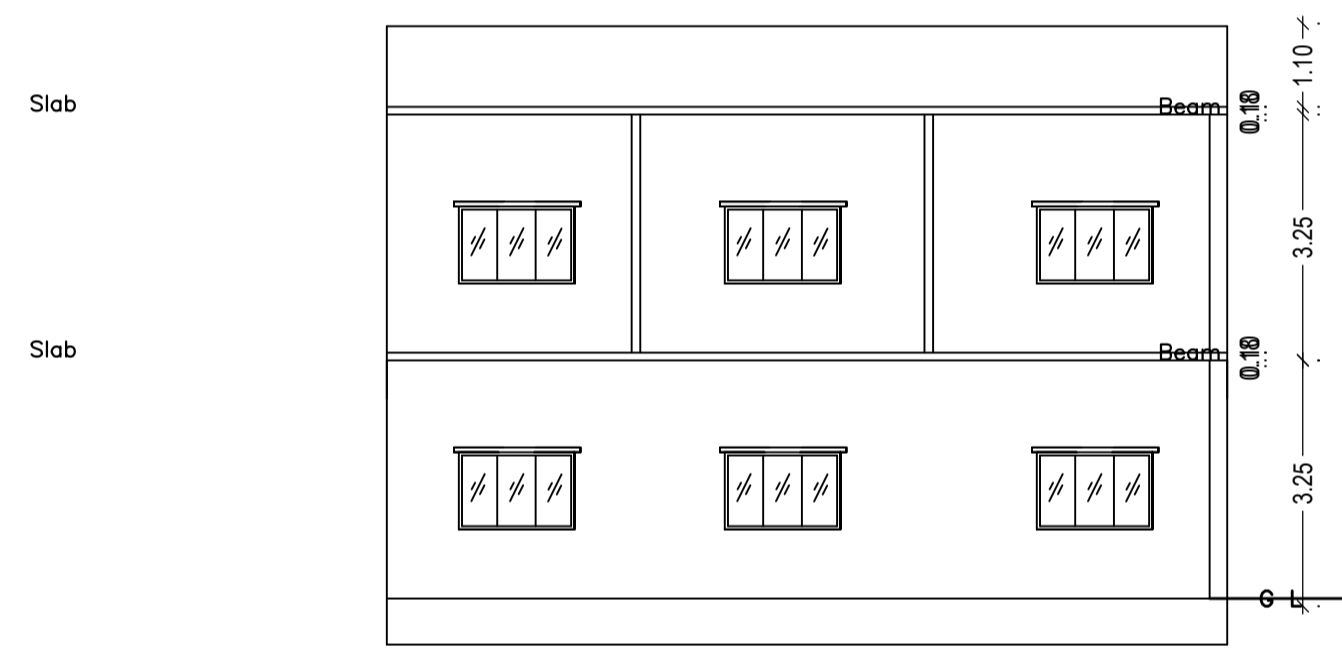

SECTION ON YY

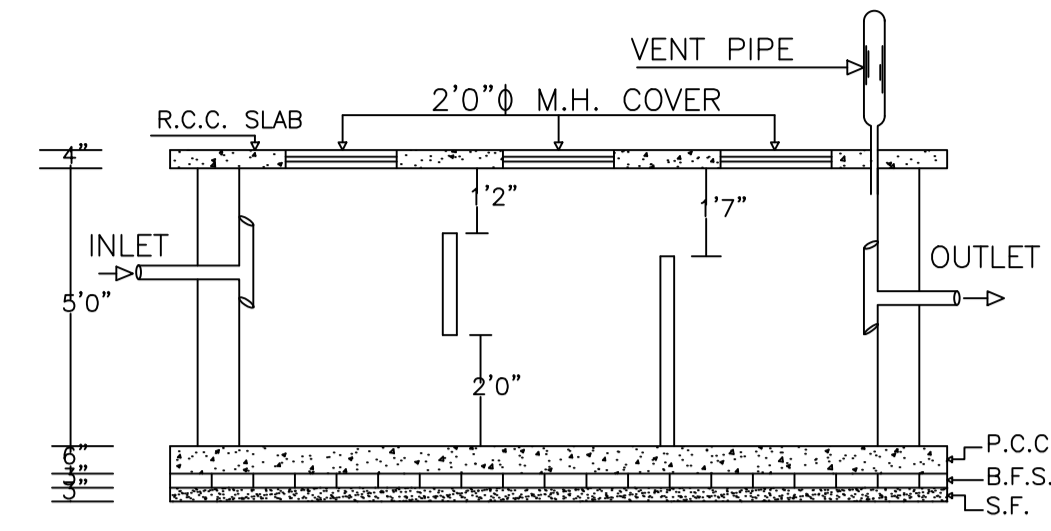

PLAN OF SEPTIC TANK
SCALE:- 1" = 4' - 0"

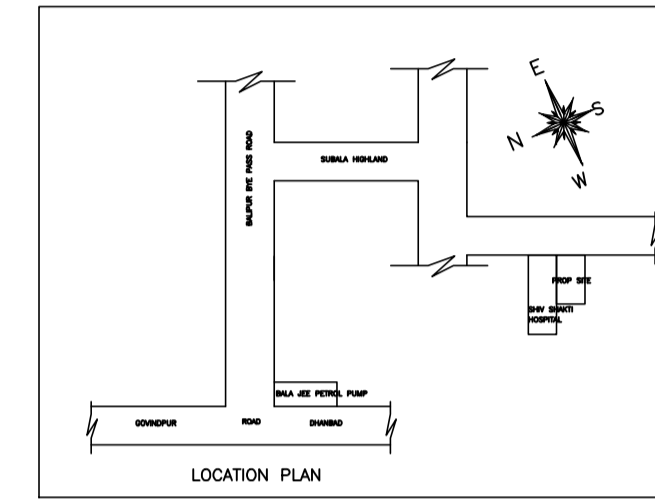

LOCATION PLAN

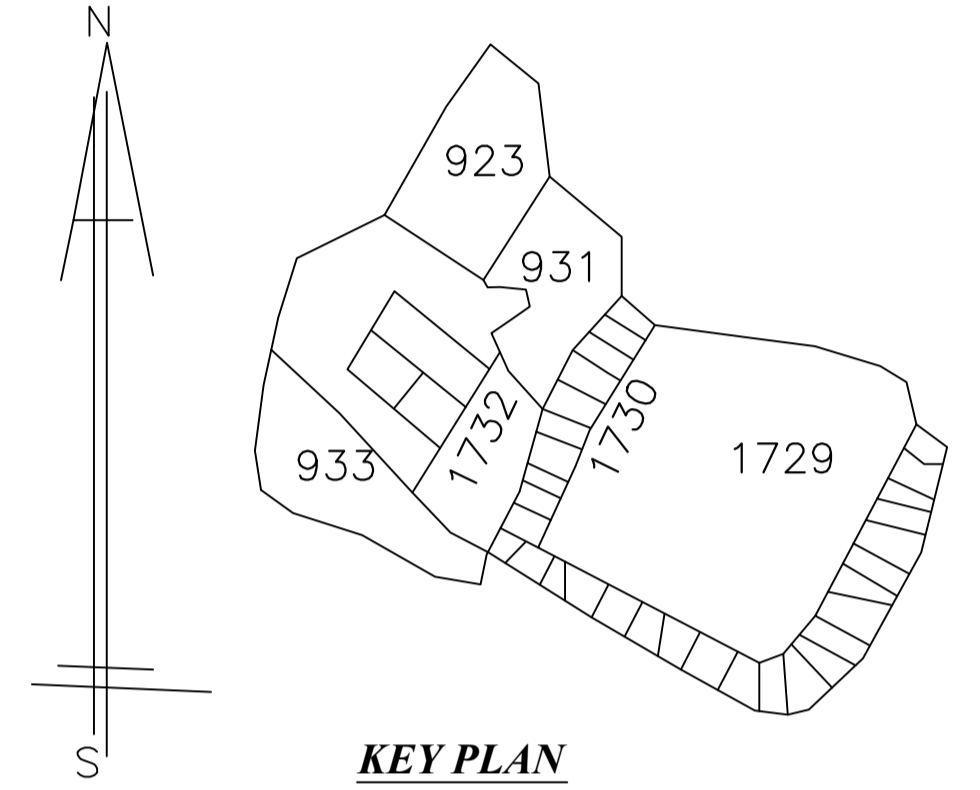

KEY PLAN
1"=330'

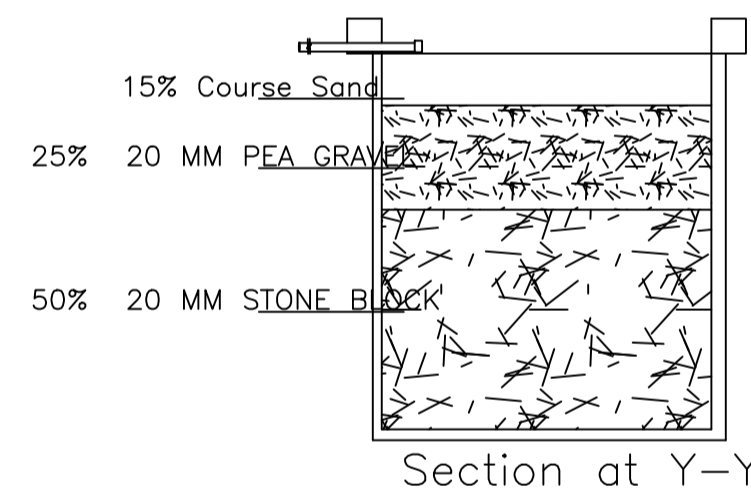

Section at Y-Y

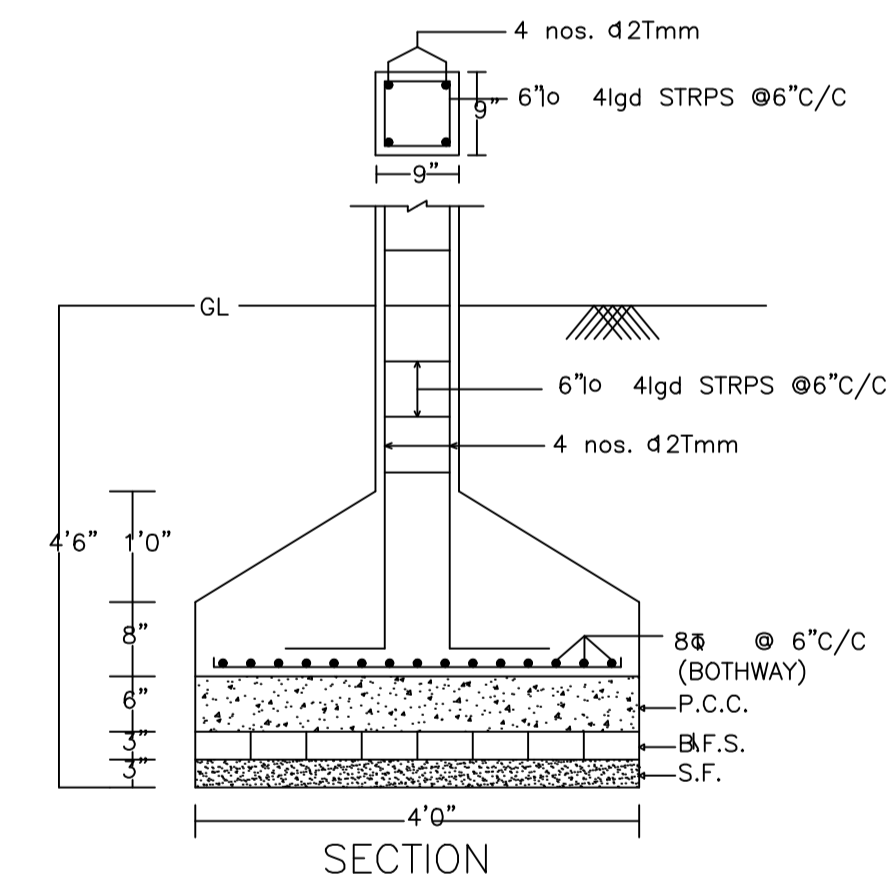

DETAIL OF COLUMNS

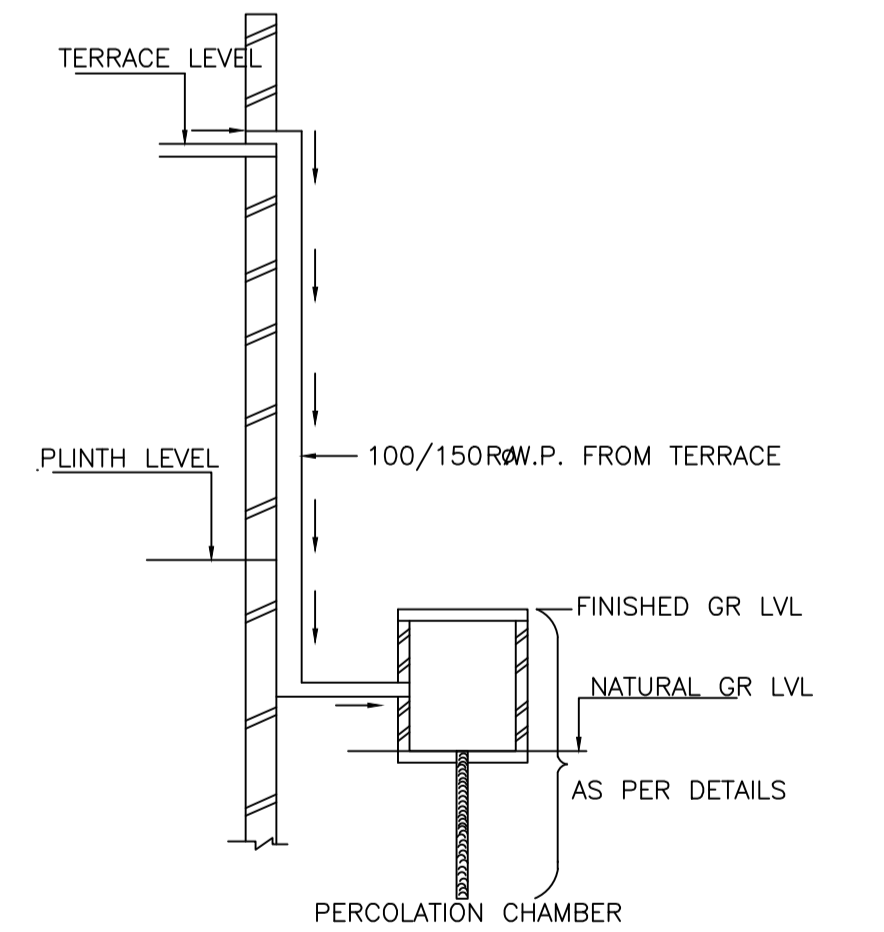

ROOF TOP RAIN WATER
COLLECTION SYSTEM

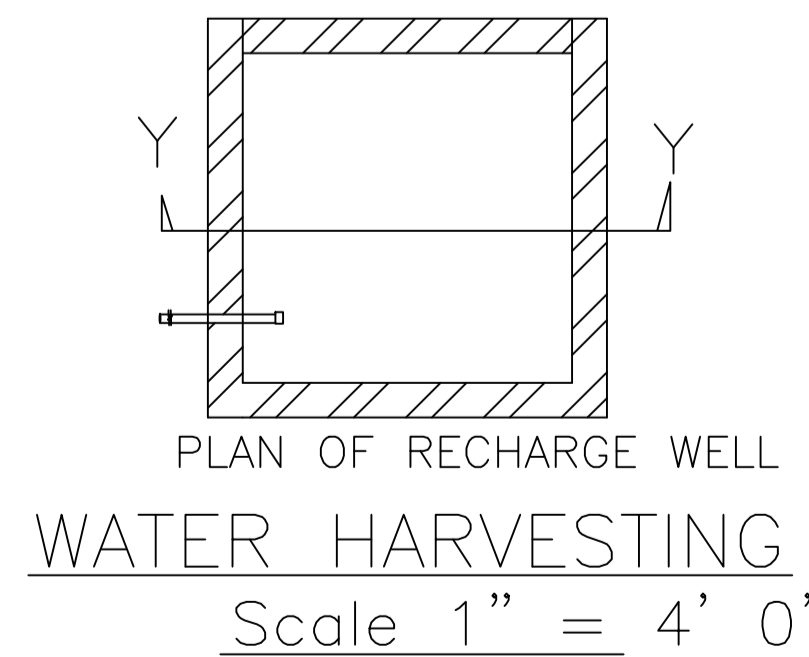

PLAN OF RECHARGE WELL
WATER HARVESTING
Scale 1" = 4' 0"

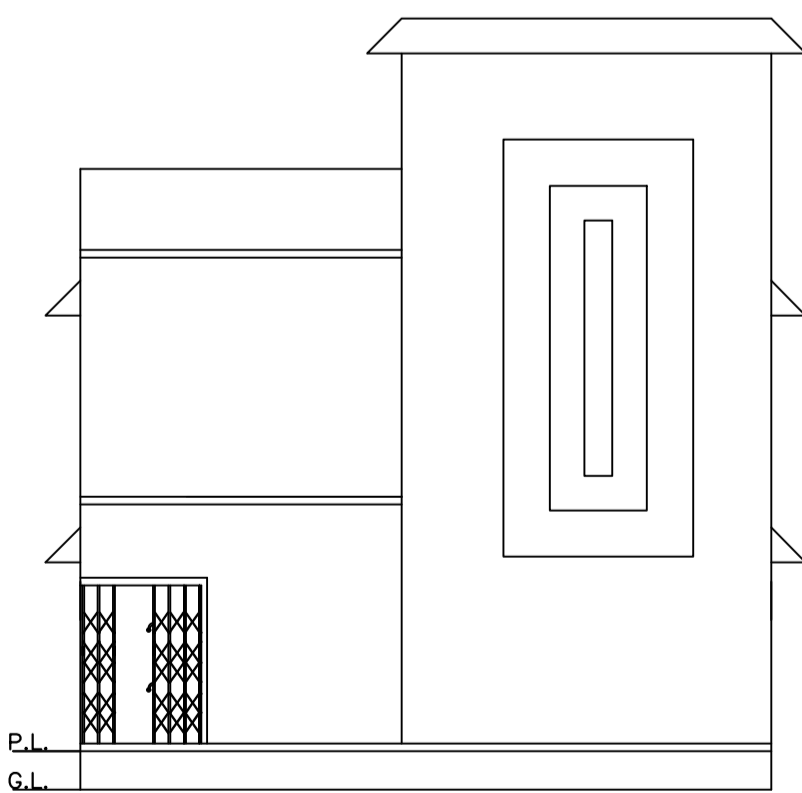

FRONT ELEVATION

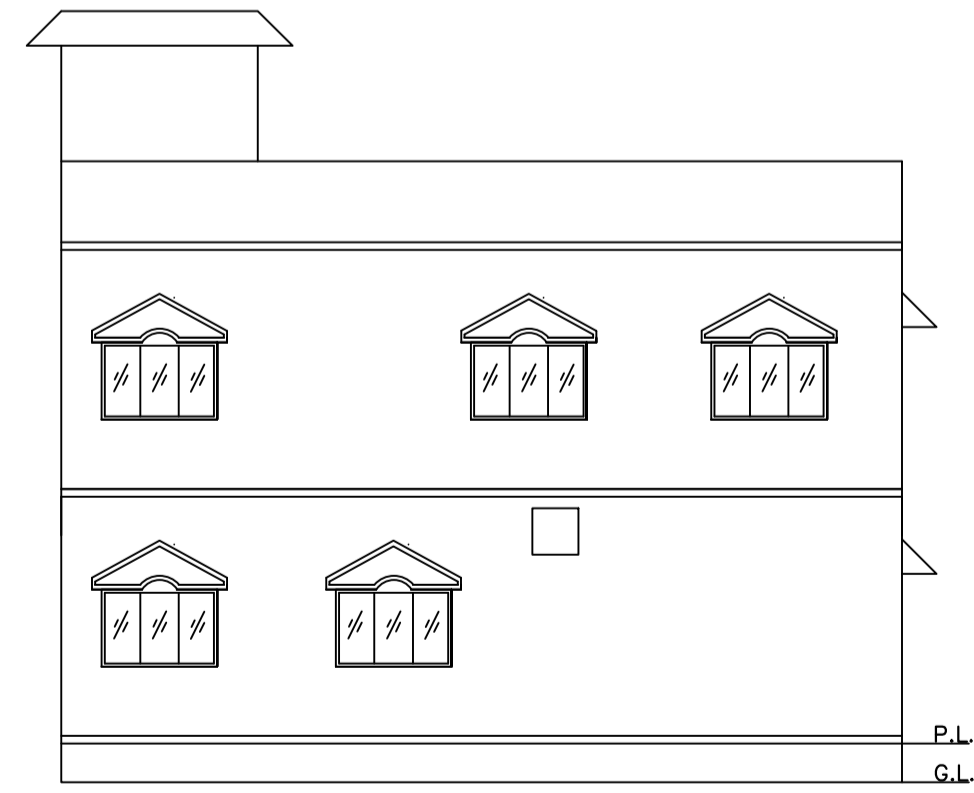

RIGHT SIDE ELEVATION

LTP NAME AND SIGNATURE	STRUCTURAL ENG'S NAME AND SIGNATURE	BUILDER NAME AND SIGNATURE	DIGITAL SIGNATURE
RAJEEV RANJAN SINGH DMC/ENG/0032/2017			