

Project Title :SHYAM PRAKASH

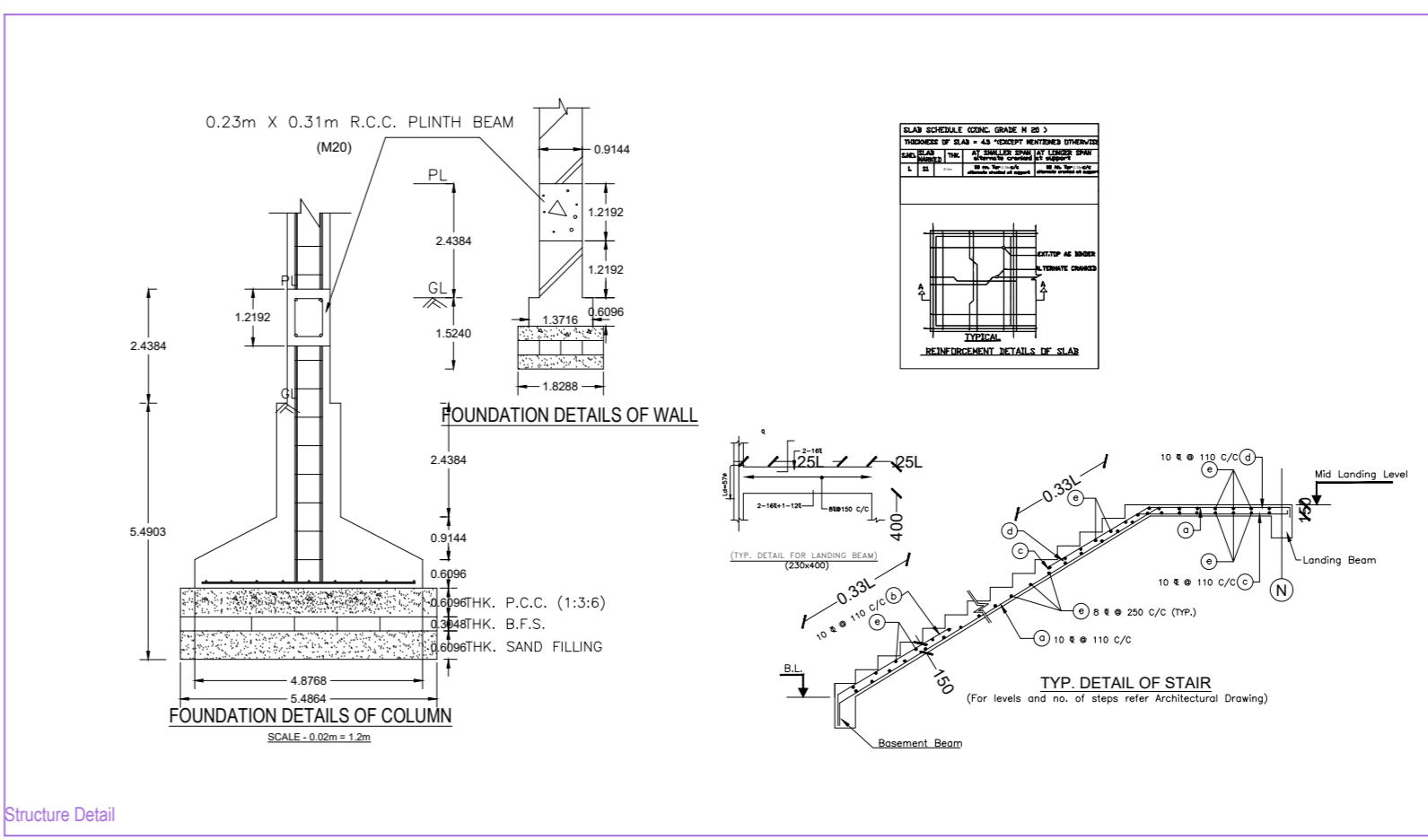
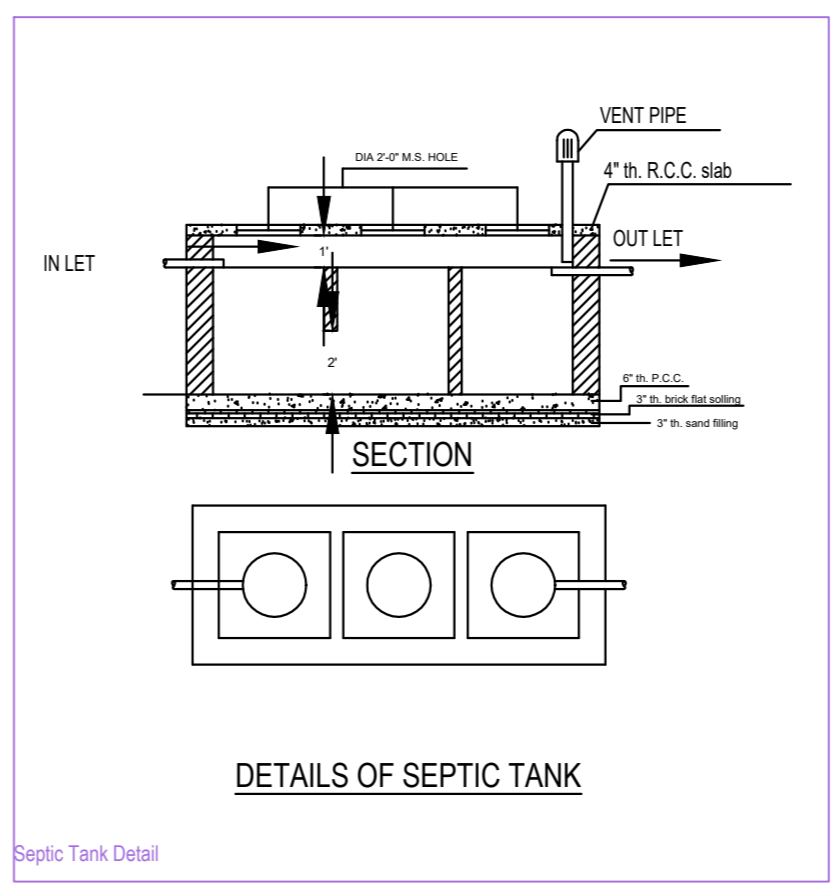
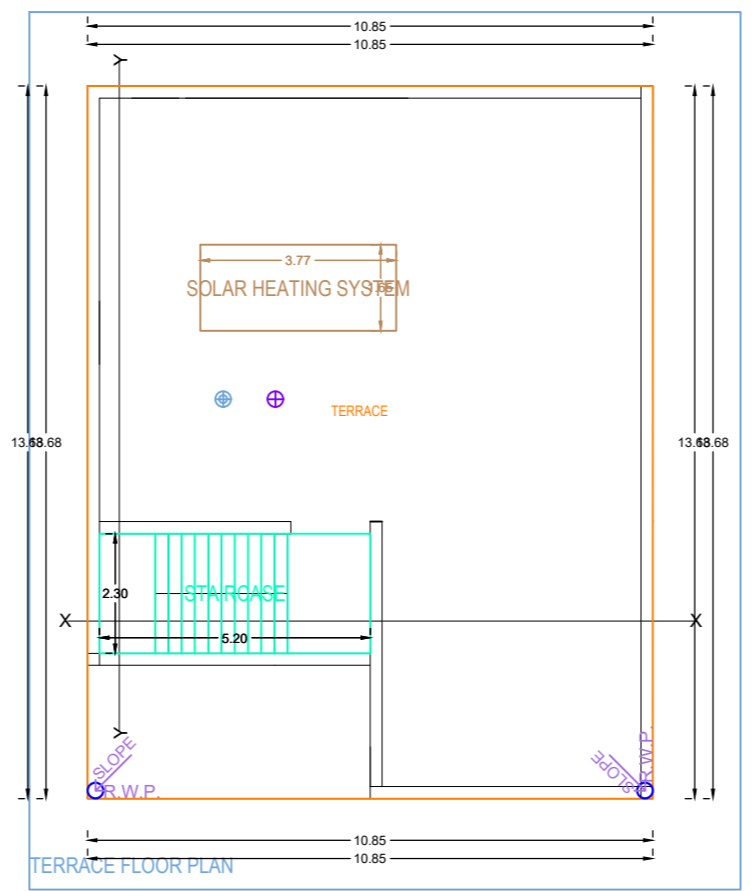
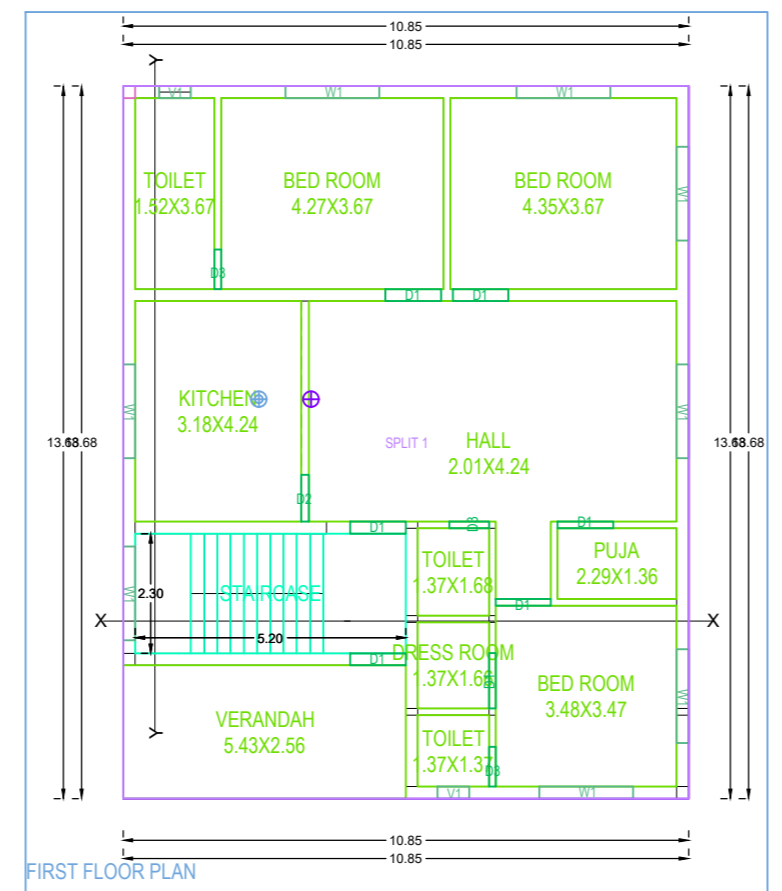
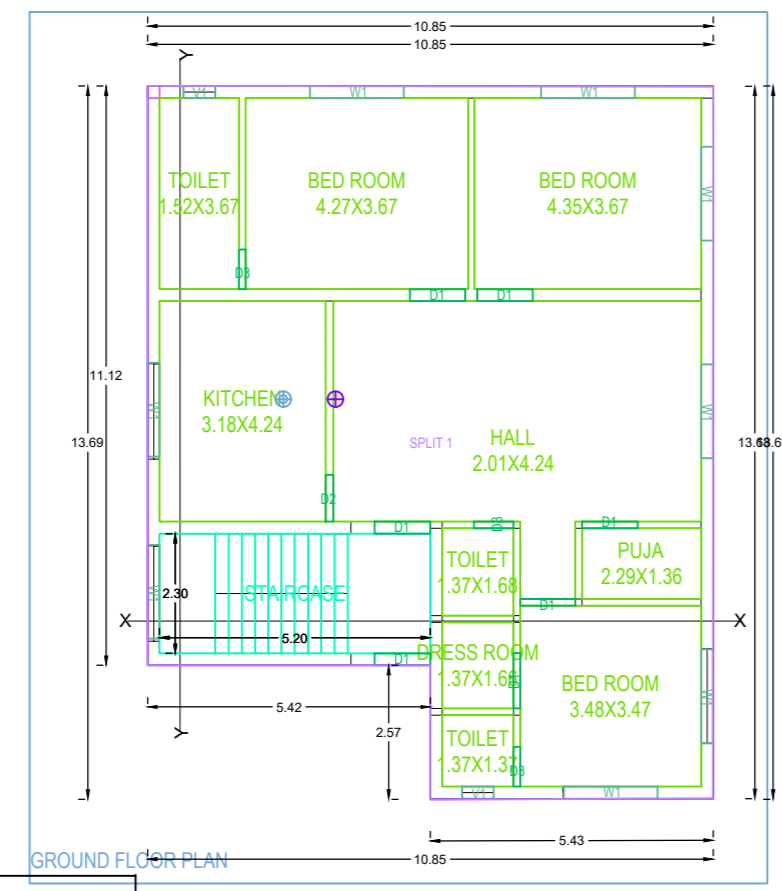
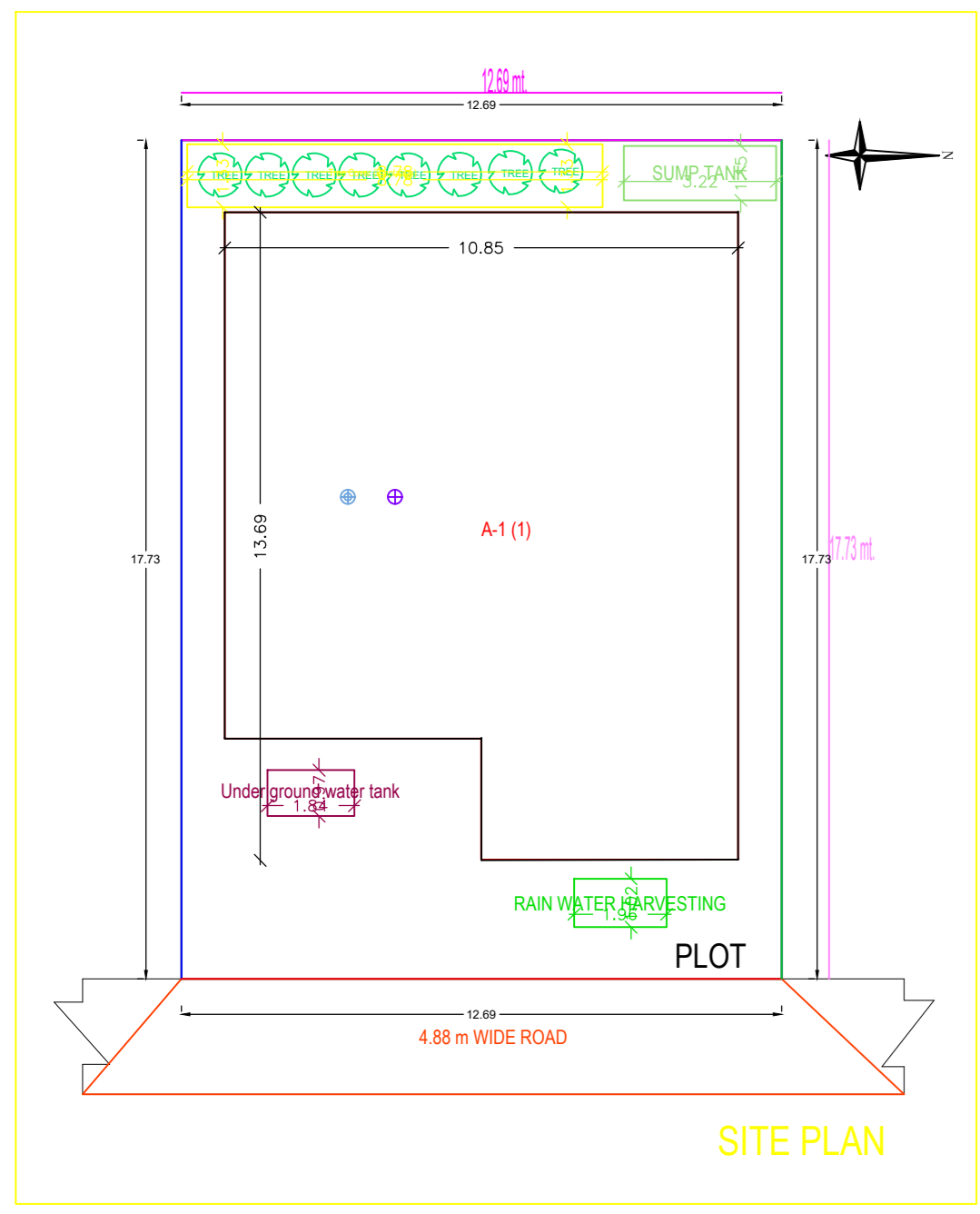
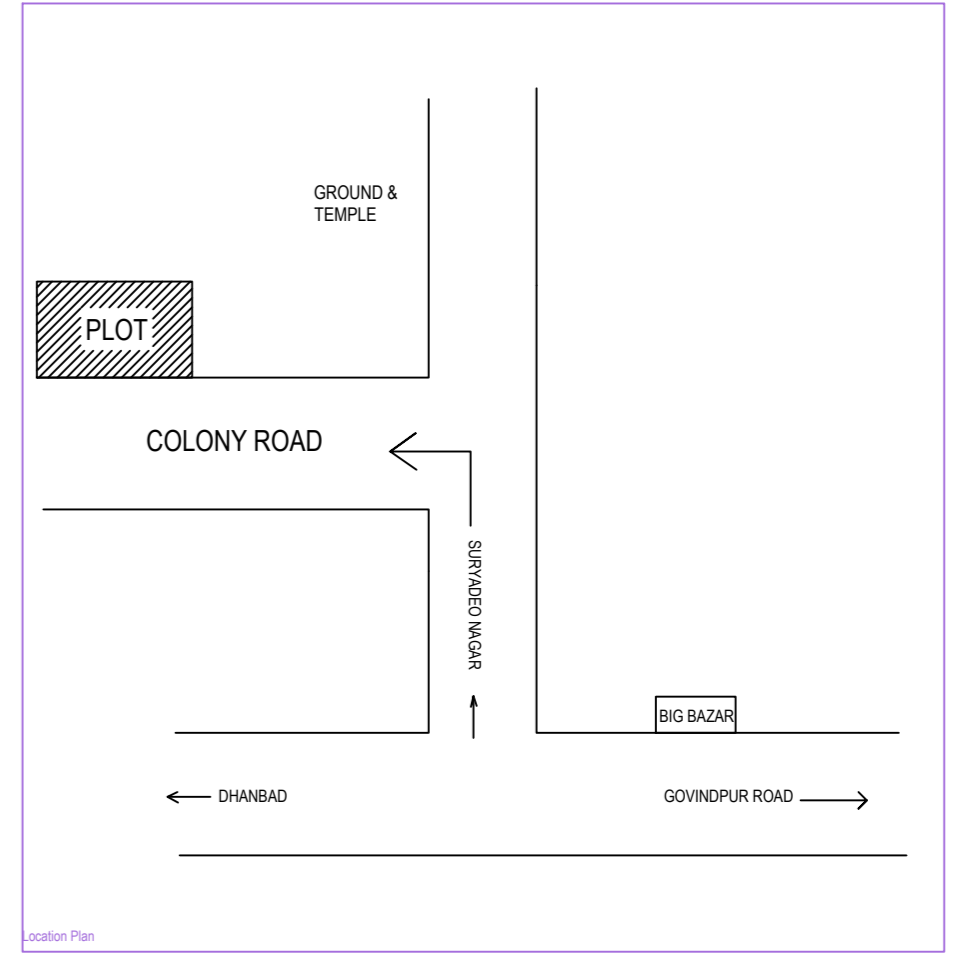
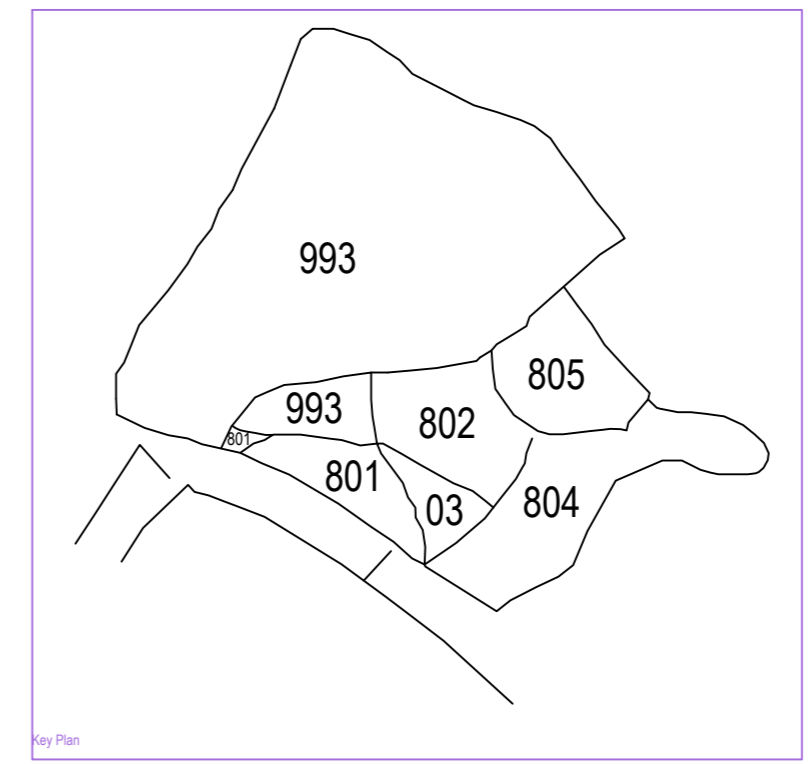
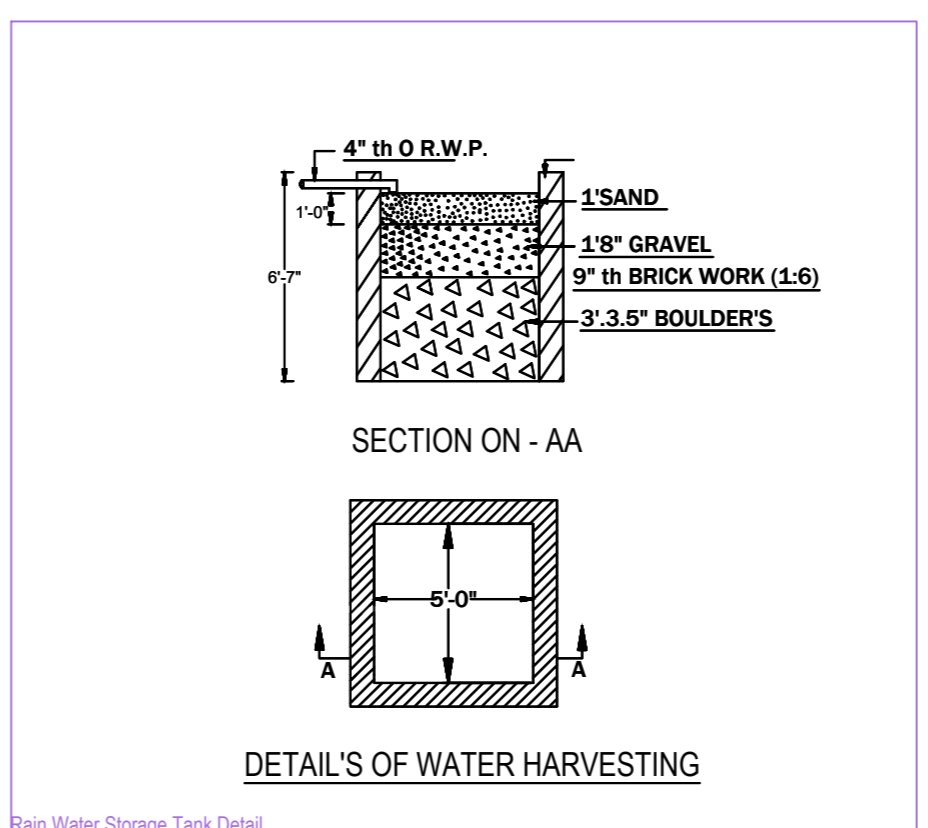
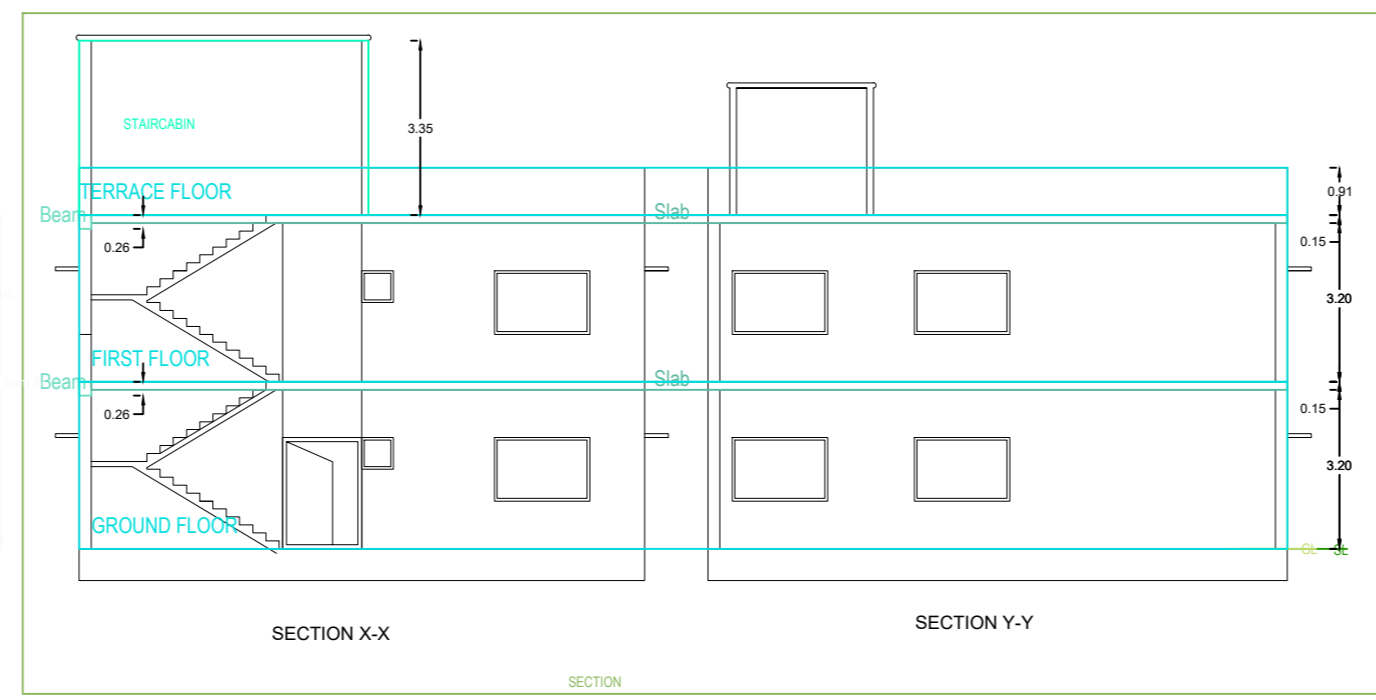
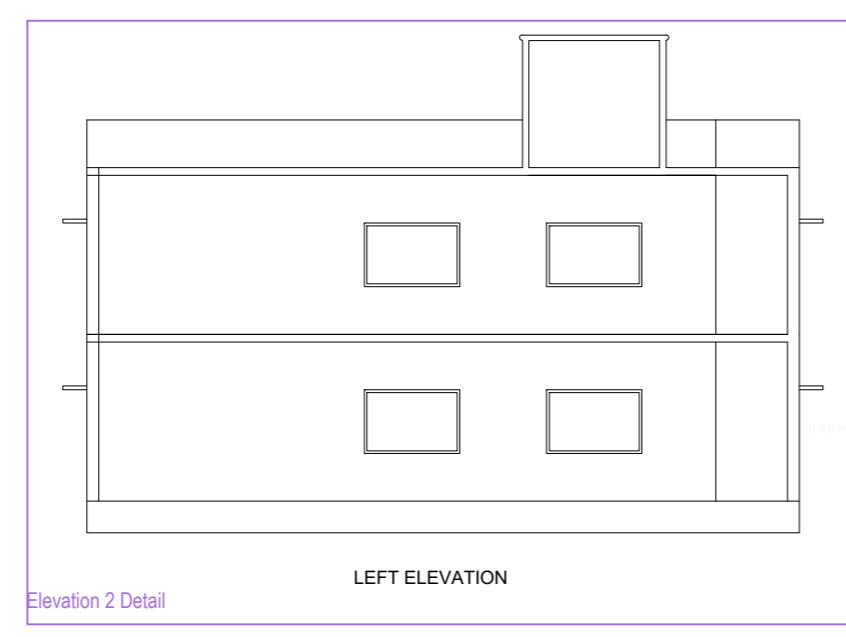
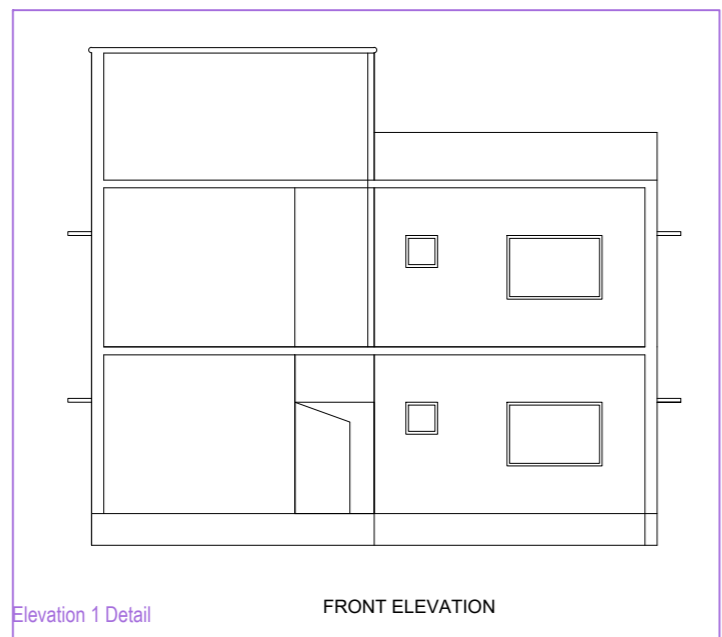

PROJECT GENERAL		SECTION NO. 1.1.01
Project Name	SHYAM PRAKASH	SECTION DATE: 10/10/2024
Client	SHYAM PRAKASH	
Location	GOVINDPUR ROAD, DELHI	
Plot Area	191.10 Sq. M	
Building Area	283.10 Sq. M	
Volume	1072.40 Cu. M	
Height	3.80 M	
Foundation	RAISED	
Roof	FLAT	
Structure	R.C.C.	
Work	CONSTRUCTION	
Scale	AS SHOWN	
Prepared By	ARCHITECT	
Checked By	ARCHITECT	
Approved By	ARCHITECT	
Date	10/10/2024	

COLOR INDEX	
WALL	White
ROOF	Grey
GLAZING	Blue
LANDSCAPE	Green
ROAD	Red
RAILROAD	Black
WATER	Blue
VEGETATION	Green
EXISTING	Yellow
PROPOSED	Red

BUILDING A (1)					
Floor Name	Total Built Up Area (Sq. M)	Plinth Area (Sq. M)	Total Floor Area (Sq. M)	Total Volume (Cu. M)	Height (M)
Ground Floor	104.45	104.45	104.45	104.45	01
First Floor	104.45	104.45	104.45	104.45	01
Terrace Floor	74.20	74.20	74.20	74.20	01
Total	283.10	283.10	283.10	283.10	03

SCHEDULE OF JOINERY					
ITEM NO.	DESCRIPTION	UNIT	QTY	REMARKS	NO. OF WORKERS
01	WOODEN DOOR	Sq. M	1.00		01
02	WOODEN WINDOW	Sq. M	2.00		02
03	WOODEN SHUTTER	Sq. M	1.00		01
04	WOODEN PARTITION	Sq. M	1.00		01
05	WOODEN ROOF	Sq. M	1.00		01

SCHEDULE OF JOINERY					
ITEM NO.	DESCRIPTION	UNIT	QTY	REMARKS	NO. OF WORKERS
01	WOODEN DOOR	Sq. M	1.00		01
02	WOODEN WINDOW	Sq. M	2.00		02
03	WOODEN SHUTTER	Sq. M	1.00		01
04	WOODEN PARTITION	Sq. M	1.00		01
05	WOODEN ROOF	Sq. M	1.00		01

UNBILTA Table for Building A (1)						
FLOOR	Area	UNBILTA Type	UNBILTA Area	Cost Area	No. of Rooms	No. of Treatment
GROUND FLOOR	104.45	UNBILTA	104.45	104.45	1	1
FIRST FLOOR	104.45	UNBILTA	104.45	104.45	1	1
TERRACE FLOOR	74.20	UNBILTA	74.20	74.20	1	1
TOTAL	283.10	UNBILTA	283.10	283.10	3	3