

Project Title :NIRAJ KUMAR YADAV AND DHIRAJ KUMAR

AREA STATEMENT DHANBAD MUNICIPAL CORPORATION		VERSION NO. 1.0.38
PROJECT DETAIL		VERSION DATE: 16/10/2020
Project No.:	NA/104/Residential	
Project Name:	Plot No. 454 (NEW : 396) Residential	
Location:	Plot No. 454 (NEW : 396) Residential	
Project Type:	Residential	
Nature of Development:	Addition or Alteration	
Location:	Plot No. 454 (NEW : 396) Residential	
Site Location:	NA	
Ward No.:	South	
Neighbourhood:	South	
Other:		

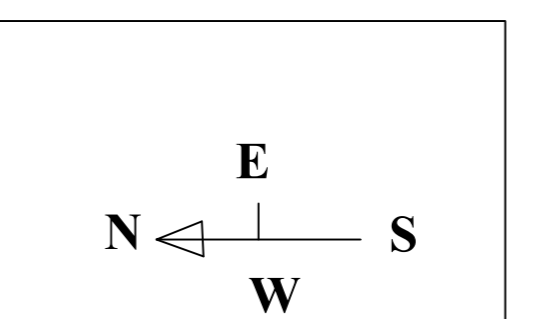
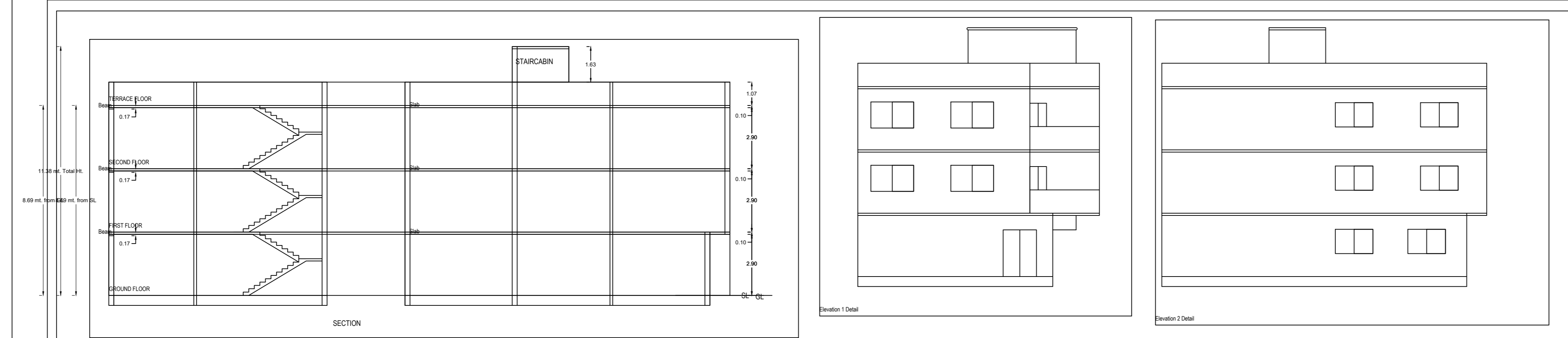

**BRIEF SPECIFICATION**  
 FOUNDATION..... CEMENT CONCRETE (1:1.5:3)  
 BRICK WORK IN FOUNDATION & SUPERSTRUCTURE  
 FIRST CLASS BRICK WORK IN CEMENT MORTAR (1:6)  
 D.P.C.....25 D.P.C. IN CEMENT CONCRETE (1:2:4)  
 FLOOR.....25 D.P.C. OVER 75 P.C.C.  
 ROOF.....100 THK. R.C.C. ROOF (1:1.5:3)  
 LINTEL.....150 THK. R.C.C. LINTEL (1:1.5:3)  
 STAIRS.....RISE-- 150, TREAD-- 250

**DETAILS OF AREA**

Building	No. of Storeys	Total Built Up Area (Sq.Mt)	Existing Built Up Area (Sq.Mt)	Proposed Built Up Area (Sq.Mt)	Existing FAR	Proposed FAR
1	1	422.17	422.17	7.70	422.17	422.17
<b>Total</b>	<b>1</b>	<b>422.17</b>	<b>422.17</b>	<b>7.70</b>	<b>422.17</b>	<b>422.17</b>

**SCHEDULE**

D = 1.200X2.100	W = 1.800X1.200
D1 = 1.050X2.100	W2 = 0.900X1.200
D2 = 0.900X2.100	V = 0.600X0.600

**TITLE OF DRAWING**  
 PROPOSED RESIDENTIAL BUILDING OF SRI NIRAJ KUMAR YADAV AND SRI DHIRAJ KUMAR BOTH S/O SUKHDEO YADAV UNDER MOUZA : KOLAKUSHMA , 12 HAVING PLOT NO. 454(NEW : 396) , KHATA NO. : 43 (NEW : 245) IN THE DIST. OF DHANBAD

SIGNATURE OF OWNER

SIGNATURE OF ENGINEER

SCALE ALL DIMENSION ARE IN METRE

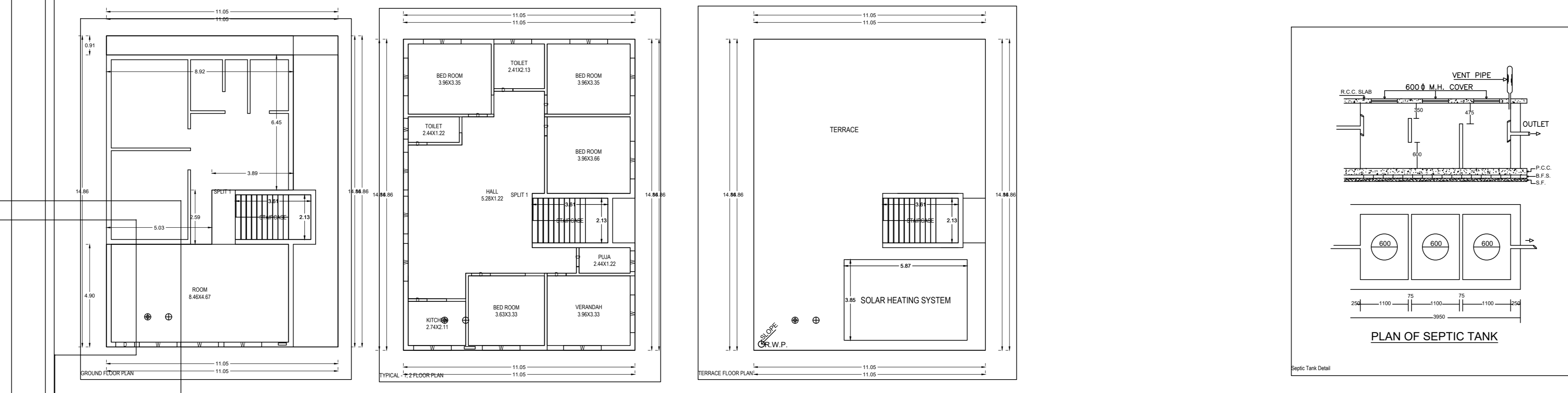
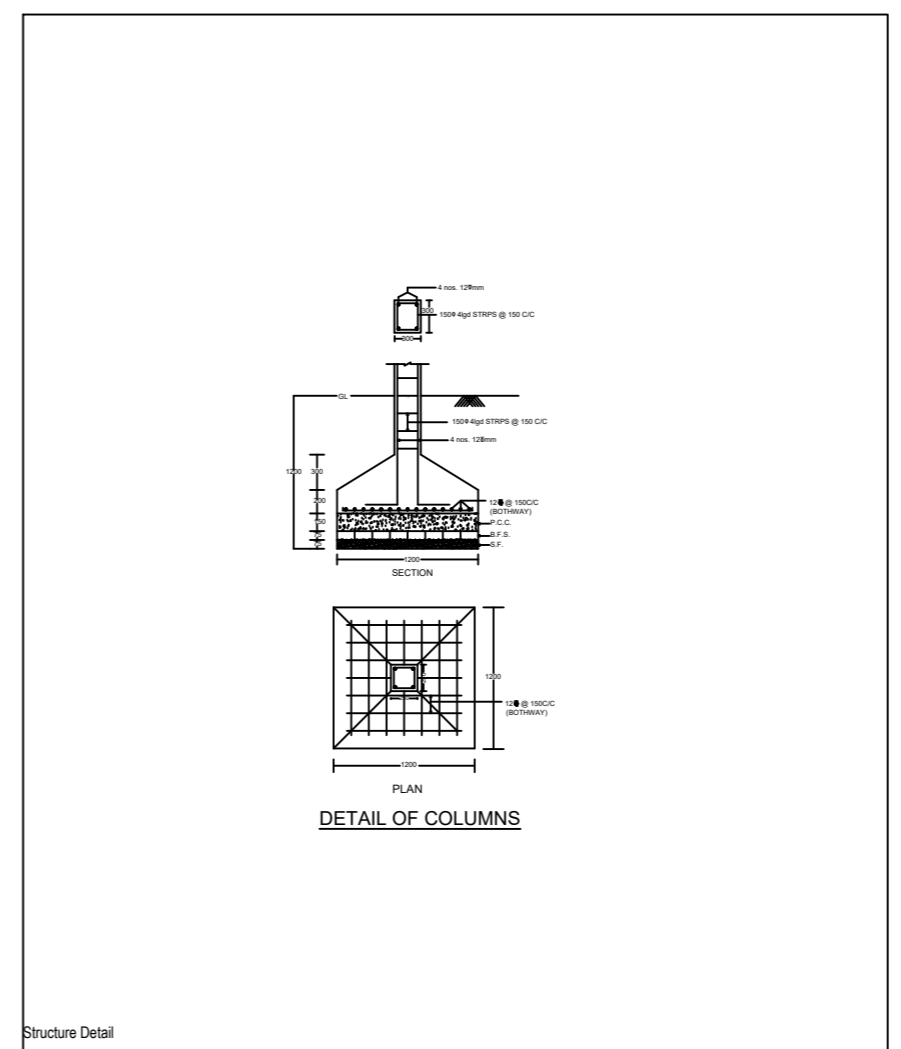
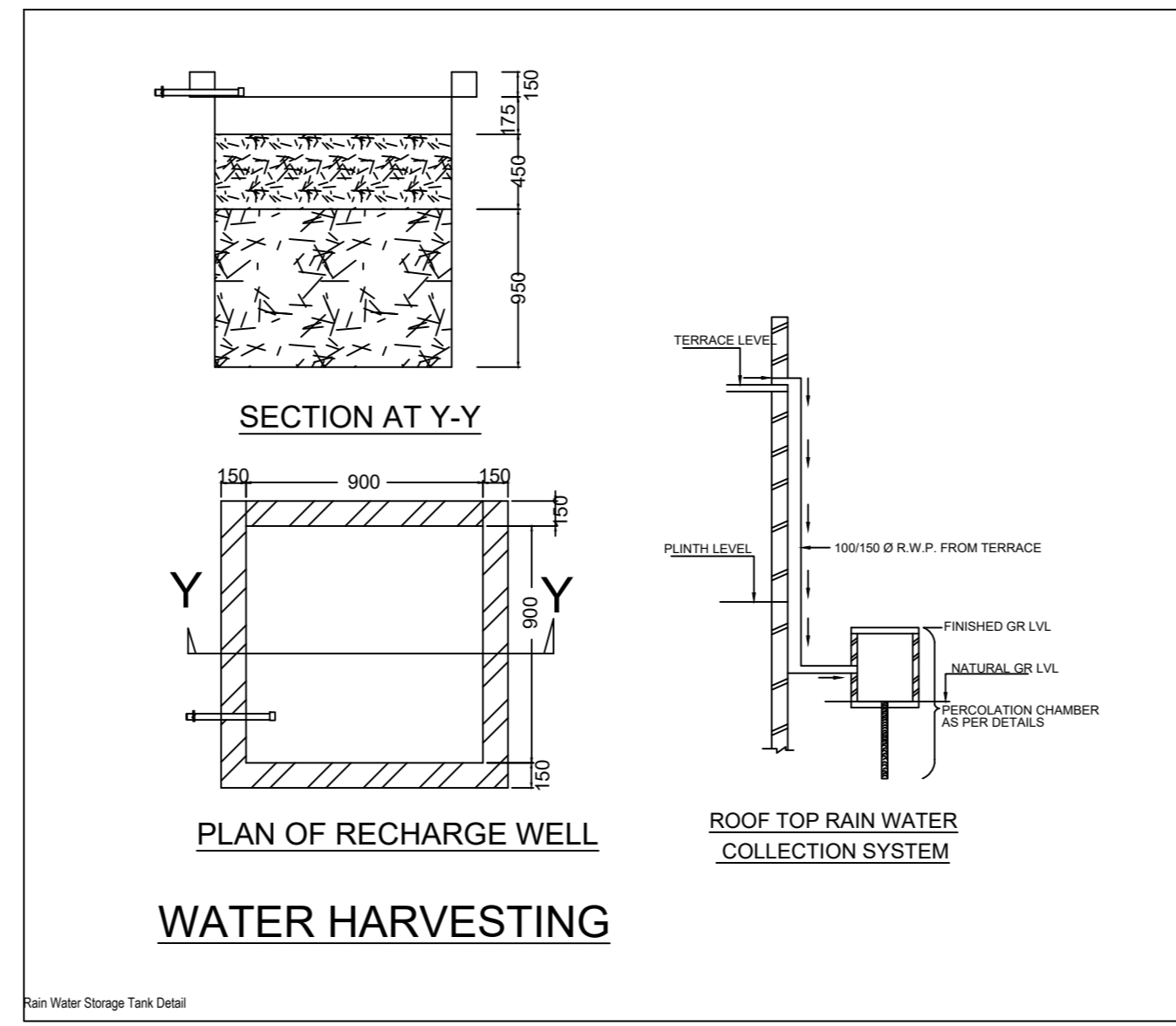
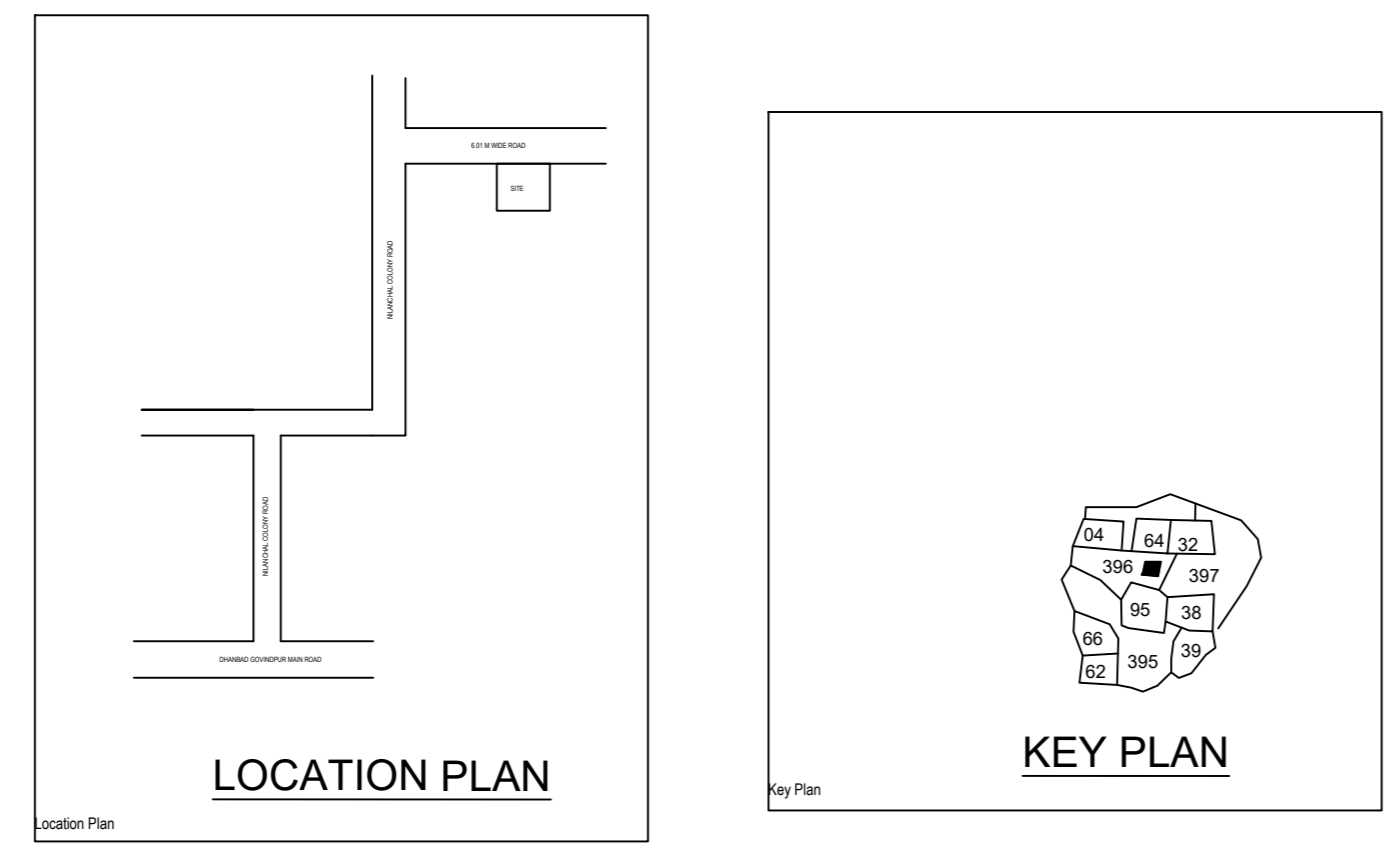
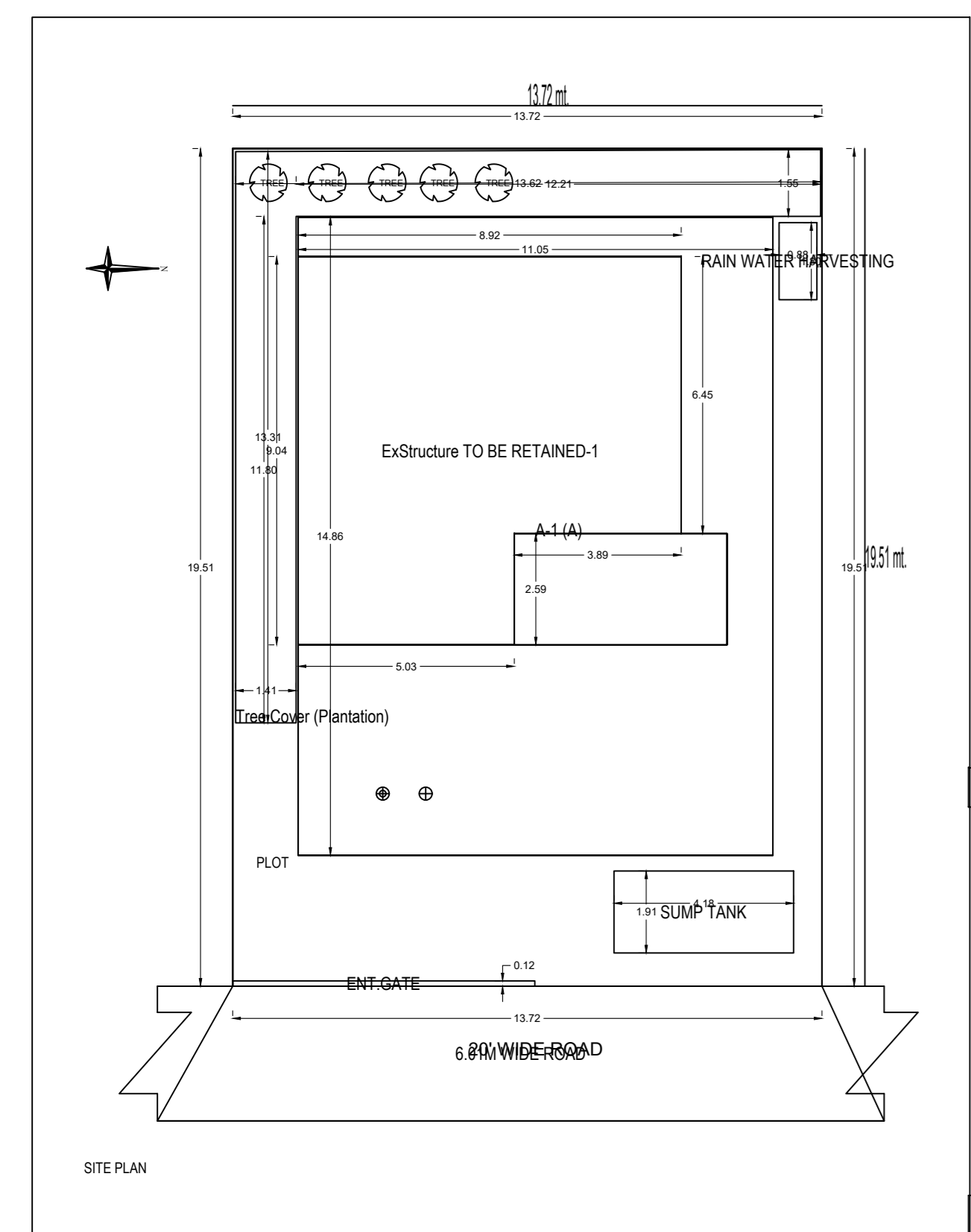

**Building A (A)**

Floor Name	Total Built Up Area (Sq.Mt)	Existing Built Up Area (Sq.Mt)	Proposed Built Up Area (Sq.Mt)	Existing FAR	Proposed FAR	Total FAR Area	Plot No.
Ground Floor	104.25	104.25	0.00	104.25	104.25	104.25	01
First Floor	104.25	104.25	0.00	104.25	104.25	104.25	01
Second Floor	104.25	104.25	0.00	104.25	104.25	104.25	01
Typical Floor	104.25	104.25	0.00	104.25	104.25	104.25	01
<b>Total</b>	<b>422.17</b>	<b>422.17</b>	<b>0.00</b>	<b>422.17</b>	<b>422.17</b>	<b>422.17</b>	<b>01</b>

**SCHEDULE OF JOINERY:**

BUILDING NAME	NAME	LENGTH	HEIGHT	NO.
A (A)	W	0.90	2.10	19

**SCHEDULE OF JOINERY:**

BUILDING NAME	NAME	LENGTH	HEIGHT	NO.
A (A)	W	1.80	1.20	20

**UnBIA Table for Building A (A)**

FLOOR	Name	UnBIA Type	Entry Type	UnBIA Area	Carpet Area	No. of Rooms	No. of Bathrooms
GROUND FLOOR	SPAT 1	Existing	-	257.92	257.92	1	1
<b>Total</b>	-	-	-	<b>257.92</b>	<b>257.92</b>	<b>1</b>	<b>1</b>

**COLOR INDEX**

Color Index	Color Name
1	Red
2	Green
3	Blue
4	Yellow
5	Black

**Color Index**

Color Index	Color Name
1	Red
2	Green
3	Blue
4	Yellow
5	Black

**Color Index**

Color Index	Color Name
1	Red
2	Green
3	Blue
4	Yellow
5	Black

**Color Index**

Color Index	Color Name
1	Red
2	Green
3	Blue
4	Yellow
5	Black

**Color Index**

Color Index	Color Name
1	Red
2	Green
3	Blue
4	Yellow
5	Black

**Color Index**

Color Index	Color Name
1	Red
2	Green
3	Blue
4	Yellow
5	Black

**Color Index**

Color Index	Color Name
1	Red
2	Green
3	Blue
4	Yellow
5	Black

**Color Index**

Color Index	Color Name
1	Red
2	Green
3	Blue
4	Yellow
5	Black

**Color Index**

Color Index	Color Name
1	Red
2	Green
3	Blue
4	Yellow
5	Black

**Color Index**

Color Index	Color Name
1	Red
2	Green
3	Blue
4	Yellow
5	Black

**Color Index**

Color Index	Color Name
1	Red
2	Green
3	Blue
4	Yellow
5	Black

**Color Index**

Color Index	Color Name
1	Red
2	Green
3	Blue
4	Yellow
5	Black

**Color Index**

Color Index	Color Name
1	Red
2	Green
3	Blue
4	Yellow
5	Black

**Color Index**

Color Index	Color Name
1	Red
2	Green
3	Blue
4	Yellow
5	Black

**Color Index**

Color Index	Color Name
1	Red
2	Green
3	Blue
4	Yellow
5	Black

**Color Index**

Color Index	Color Name
1	Red
2	Green
3	Blue
4	Yellow
5	Black

**Color Index**

Color Index	Color Name
1	Red
2	Green
3	Blue
4	Yellow
5	Black