

NO.	DESCRIPTION	DATE	BY	CHECKED
1	ISSUED FOR PERMIT	2023-10-15	J.M.	A.S.
2	ISSUED FOR CONSTRUCTION	2023-11-01	J.M.	A.S.
3	ISSUED FOR OCCUPANCY	2024-01-15	J.M.	A.S.

NO.	DESCRIPTION	DATE	BY	CHECKED
1	ISSUED FOR PERMIT	2023-10-15	J.M.	A.S.
2	ISSUED FOR CONSTRUCTION	2023-11-01	J.M.	A.S.
3	ISSUED FOR OCCUPANCY	2024-01-15	J.M.	A.S.

NO.	DESCRIPTION	DATE	BY	CHECKED
1	ISSUED FOR PERMIT	2023-10-15	J.M.	A.S.
2	ISSUED FOR CONSTRUCTION	2023-11-01	J.M.	A.S.
3	ISSUED FOR OCCUPANCY	2024-01-15	J.M.	A.S.

NO.	DESCRIPTION	DATE	BY	CHECKED
1	ISSUED FOR PERMIT	2023-10-15	J.M.	A.S.
2	ISSUED FOR CONSTRUCTION	2023-11-01	J.M.	A.S.
3	ISSUED FOR OCCUPANCY	2024-01-15	J.M.	A.S.

NO.	DESCRIPTION	DATE	BY	CHECKED
1	ISSUED FOR PERMIT	2023-10-15	J.M.	A.S.
2	ISSUED FOR CONSTRUCTION	2023-11-01	J.M.	A.S.
3	ISSUED FOR OCCUPANCY	2024-01-15	J.M.	A.S.

NO.	DESCRIPTION	DATE	BY	CHECKED
1	ISSUED FOR PERMIT	2023-10-15	J.M.	A.S.
2	ISSUED FOR CONSTRUCTION	2023-11-01	J.M.	A.S.
3	ISSUED FOR OCCUPANCY	2024-01-15	J.M.	A.S.

NO.	DESCRIPTION	DATE	BY	CHECKED
1	ISSUED FOR PERMIT	2023-10-15	J.M.	A.S.
2	ISSUED FOR CONSTRUCTION	2023-11-01	J.M.	A.S.
3	ISSUED FOR OCCUPANCY	2024-01-15	J.M.	A.S.

NO.	DESCRIPTION	DATE	BY	CHECKED
1	ISSUED FOR PERMIT	2023-10-15	J.M.	A.S.
2	ISSUED FOR CONSTRUCTION	2023-11-01	J.M.	A.S.
3	ISSUED FOR OCCUPANCY	2024-01-15	J.M.	A.S.

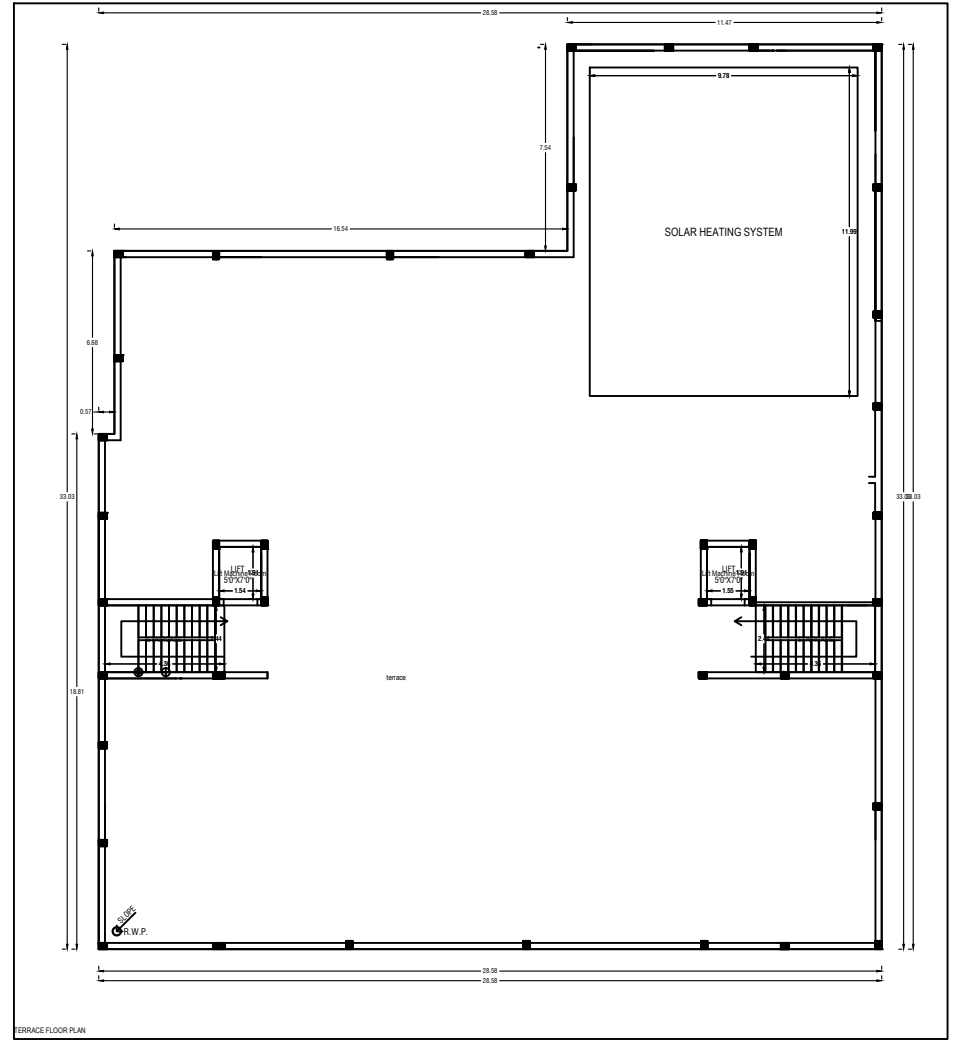
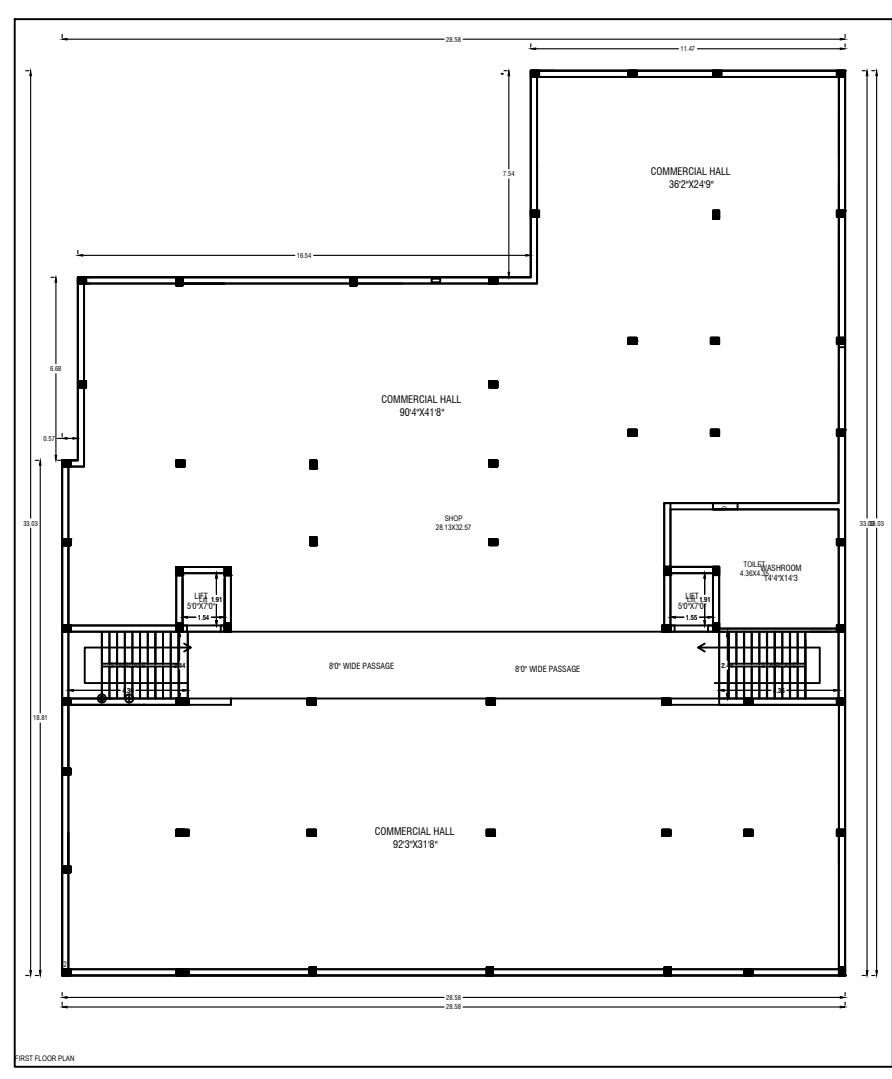
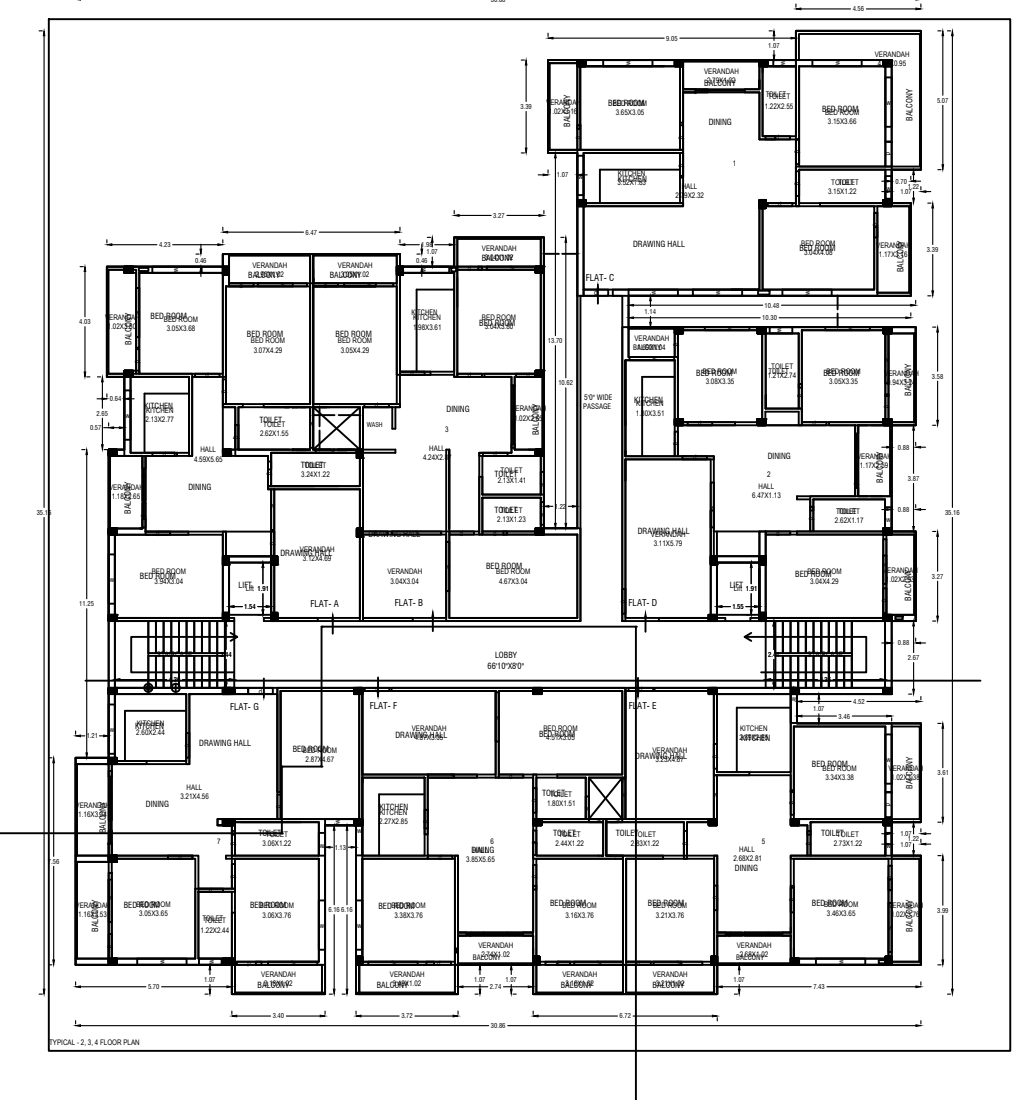
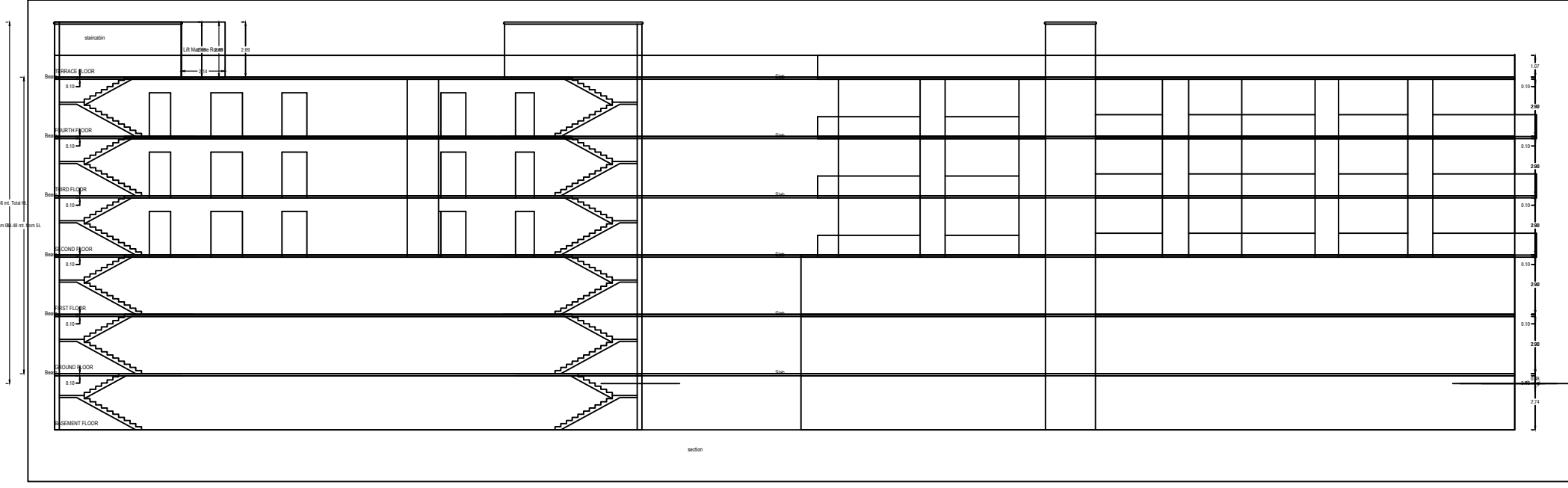
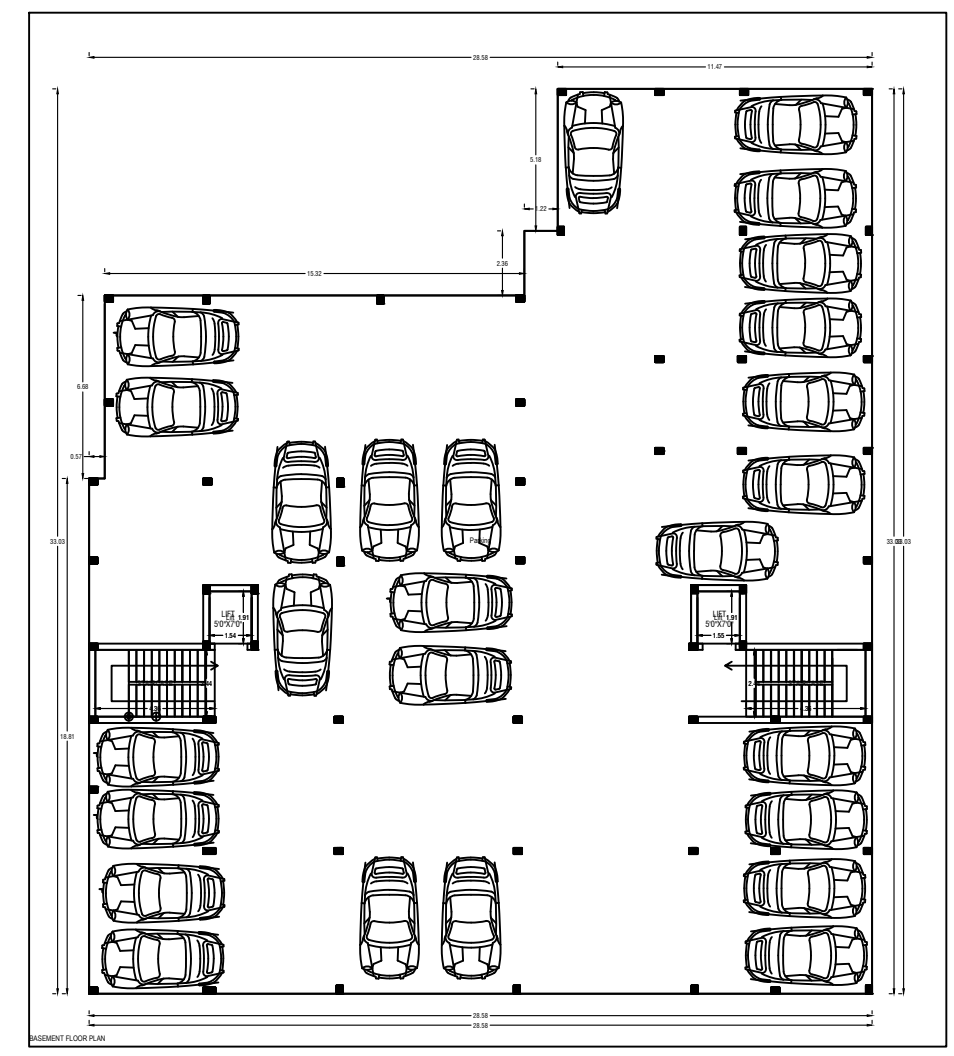
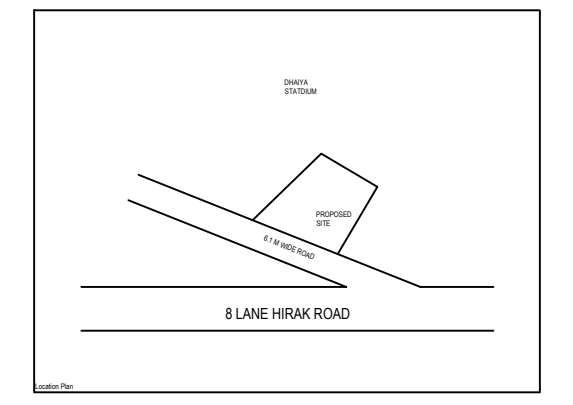
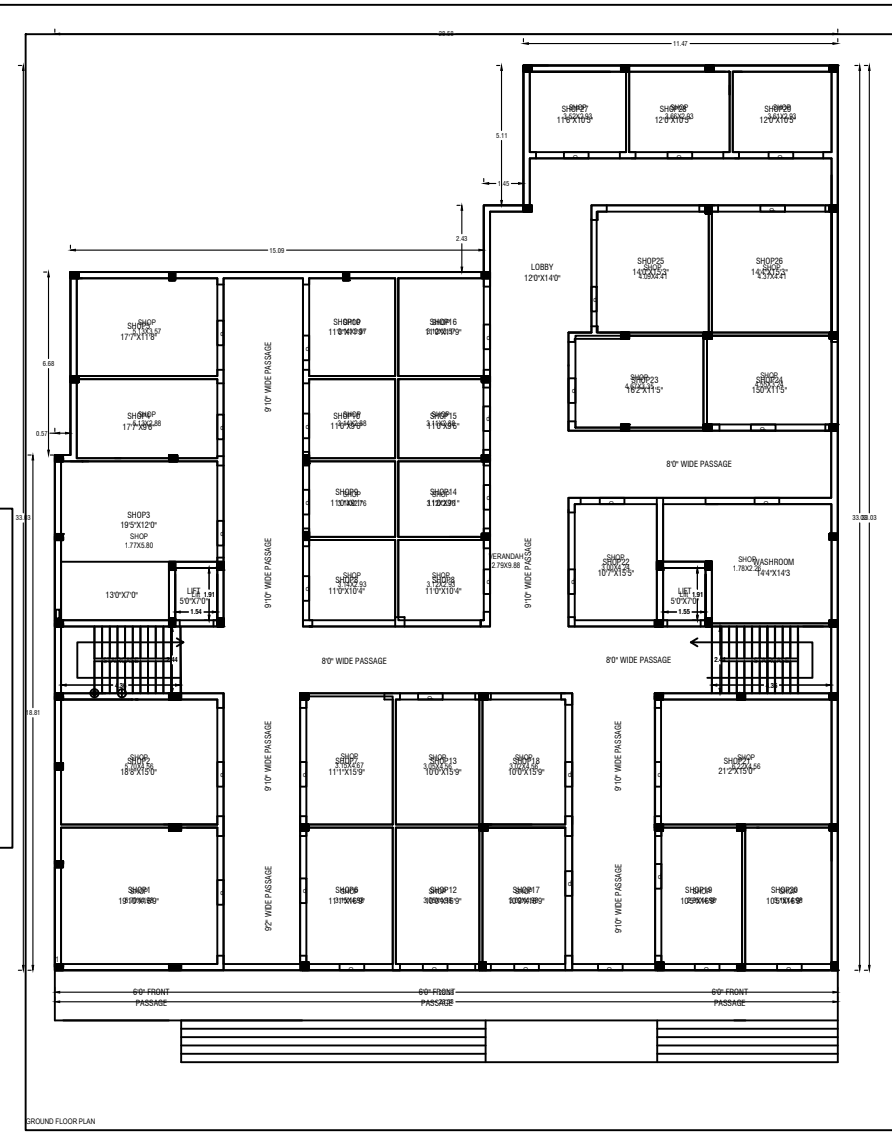
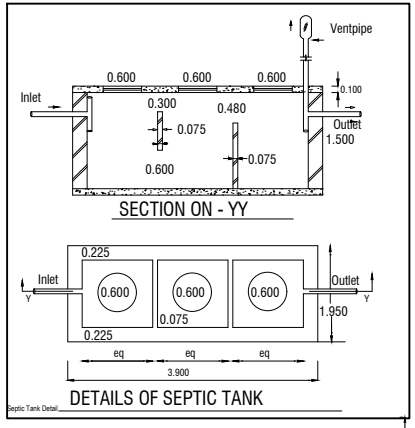
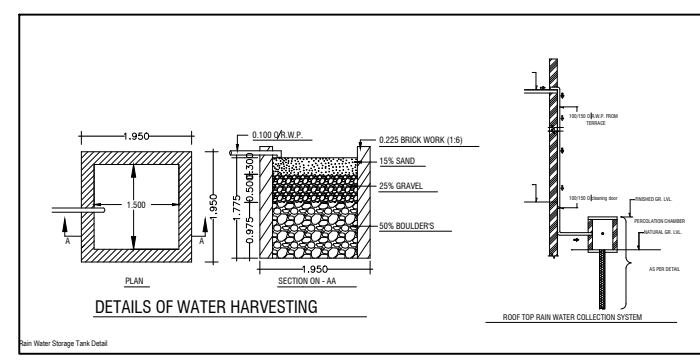
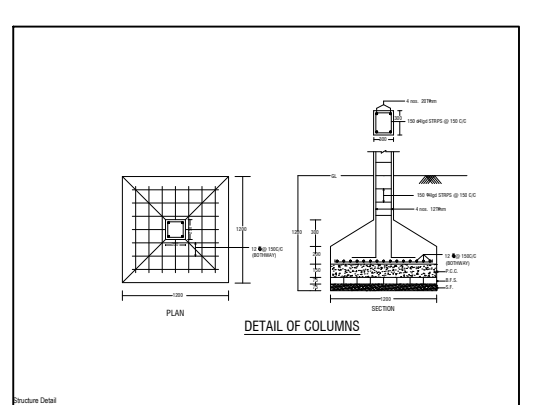
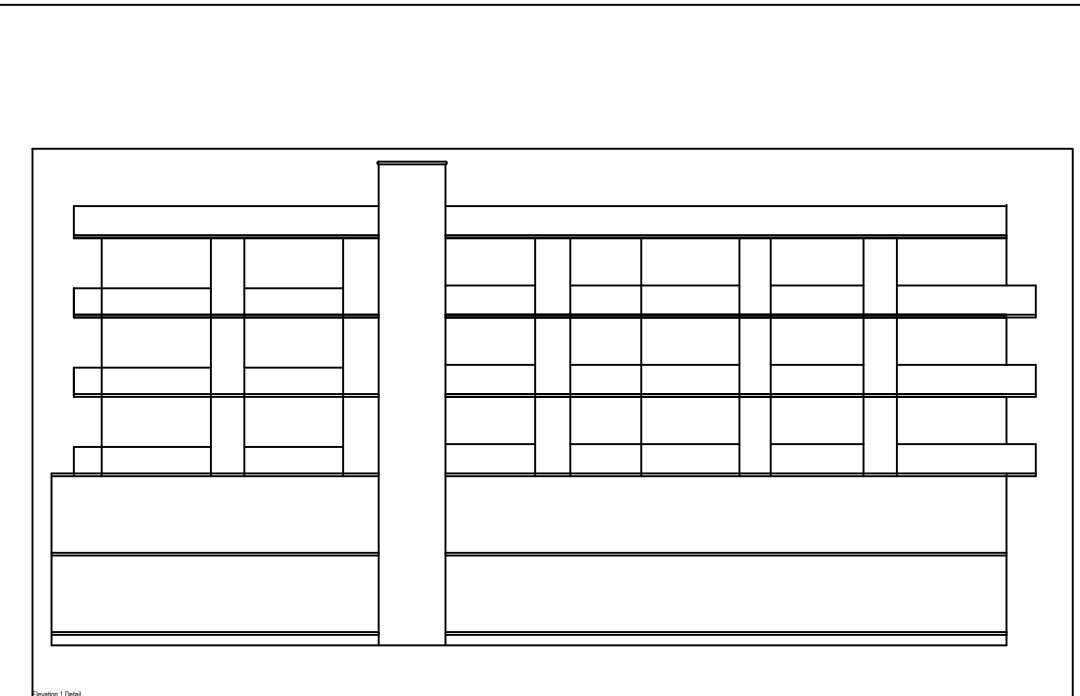
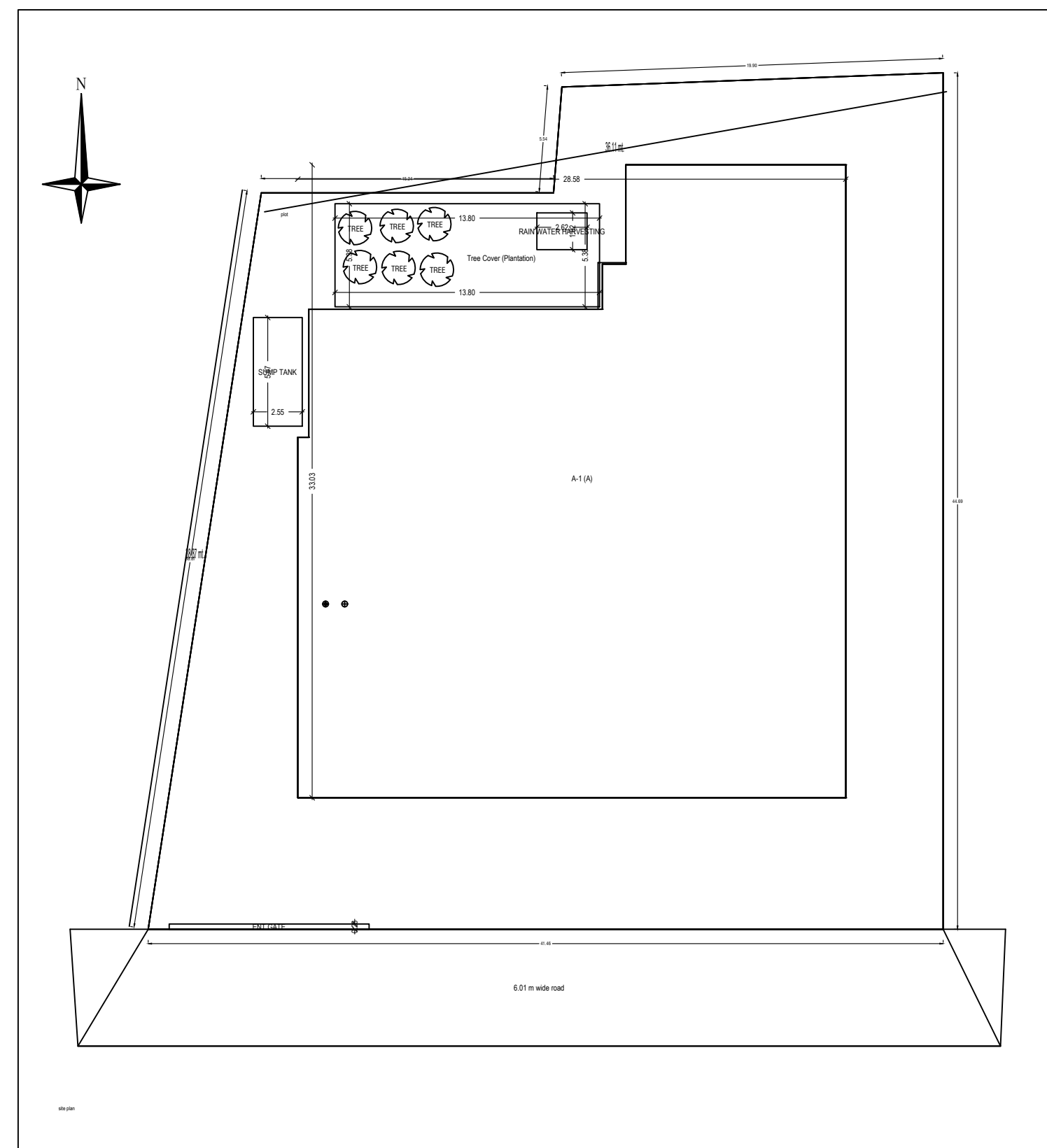

BRIEF SPECIFICATION

FOUNDATION - M.C.C. (1:1.5) Cast-in-situ foundation.
 PLASTER - 12mm M.C.C. (1:1.5) all round on plaster level.
 ROOFING - 120mm P.C. Slab with 20mm M.C.C. (1:1.5).
 SUPER STRUCTURE - First class brick work in cement mortar (1:4).
 SLAB BEAM & LINTLS - All cast in-situ with 1:1.5 M.C.C. (1:1.5).
 WOOD WORK - All door & window frames of solid wood.
 PLASTERING - 12mm cement plaster (1:4) both side.

SCHEDULE

NO.	DESCRIPTION	QTY	UNIT	PRICE	TOTAL
01	FOUNDATION	100	M ³	1500	150000
02	ROOFING	100	M ²	1200	120000
03	WALLS	100	M ²	1800	180000
04	FLOORS	100	M ²	1000	100000
05	DOORS	10	NO.	2000	20000
06	WINDOWS	20	NO.	1500	30000
07	PLASTERING	100	M ²	100	10000
08	PAINTING	100	M ²	100	10000
09	ROOFING	100	M ²	100	10000
10	WOODWORK	100	M ²	100	10000
11	SEWERAGE	100	M	100	10000
12	WATER SUPPLY	100	M	100	10000
13	ELECTRICAL	100	M	100	10000
14	MECHANICAL	100	M	100	10000
15	LANDSCAPING	100	M ²	100	10000
16	CONCRETE	100	M ³	100	10000
17	IRONWORK	100	M ²	100	10000
18	GLASS	100	M ²	100	10000
19	CEILING	100	M ²	100	10000
20	FLOORING	100	M ²	100	10000
21	MECHANICAL	100	M	100	10000
22	ELECTRICAL	100	M	100	10000
23	PLASTERING	100	M ²	100	10000
24	PAINTING	100	M ²	100	10000
25	ROOFING	100	M ²	100	10000
26	WOODWORK	100	M ²	100	10000
27	SEWERAGE	100	M	100	10000
28	WATER SUPPLY	100	M	100	10000
29	ELECTRICAL	100	M	100	10000
30	MECHANICAL	100	M	100	10000
31	LANDSCAPING	100	M ²	100	10000
32	CONCRETE	100	M ³	100	10000
33	IRONWORK	100	M ²	100	10000
34	GLASS	100	M ²	100	10000
35	CEILING	100	M ²	100	10000
36	FLOORING	100	M ²	100	10000
37	MECHANICAL	100	M	100	10000
38	ELECTRICAL	100	M	100	10000
39	PLASTERING	100	M ²	100	10000
40	PAINTING	100	M ²	100	10000
41	ROOFING	100	M ²	100	10000
42	WOODWORK	100	M ²	100	10000
43	SEWERAGE	100	M	100	10000
44	WATER SUPPLY	100	M	100	10000
45	ELECTRICAL	100	M	100	10000
46	MECHANICAL	100	M	100	10000
47	LANDSCAPING	100	M ²	100	10000
48	CONCRETE	100	M ³	100	10000
49	IRONWORK	100	M ²	100	10000
50	GLASS	100	M ²	100	10000
51	CEILING	100	M ²	100	10000
52	FLOORING	100	M ²	100	10000
53	MECHANICAL	100	M	100	10000
54	ELECTRICAL	100	M	100	10000
55	PLASTERING	100	M ²	100	10000
56	PAINTING	100	M ²	100	10000
57	ROOFING	100	M ²	100	10000
58	WOODWORK	100	M ²	100	10000
59	SEWERAGE	100	M	100	10000
60	WATER SUPPLY	100	M	100	10000
61	ELECTRICAL	100	M	100	10000
62	MECHANICAL	100	M	100	10000
63	LANDSCAPING	100	M ²	100	10000
64	CONCRETE	100	M ³	100	10000
65	IRONWORK	100	M ²	100	10000
66	GLASS	100	M ²	100	10000
67	CEILING	100	M ²	100	10000
68	FLOORING	100	M ²	100	10000
69	MECHANICAL	100	M	100	10000
70	ELECTRICAL	100	M	100	10000
71	PLASTERING	100	M ²	100	10000
72	PAINTING	100	M ²	100	10000
73	ROOFING	100	M ²	100	10000
74	WOODWORK	100	M ²	100	10000
75	SEWERAGE	100	M	100	10000
76	WATER SUPPLY	100	M	100	10000
77	ELECTRICAL	100	M	100	10000
78	MECHANICAL	100	M	100	10000
79	LANDSCAPING	100	M ²	100	10000
80	CONCRETE	100	M ³	100	10000
81	IRONWORK	100	M ²	100	10000
82	GLASS	100	M ²	100	10000
83	CEILING	100	M ²	100	10000
84	FLOORING	100	M ²	100	10000
85	MECHANICAL	100	M	100	10000
86	ELECTRICAL	100	M	100	10000
87	PLASTERING	100	M ²	100	10000
88	PAINTING	100	M ²	100	10000
89	ROOFING	100	M ²	100	10000
90	WOODWORK	100	M ²	100	10000
91	SEWERAGE	100	M	100	10000
92	WATER SUPPLY	100	M	100	10000
93	ELECTRICAL	100	M	100	10000
94	MECHANICAL	100	M	100	10000
95	LANDSCAPING	100	M ²	100	10000
96	CONCRETE	100	M ³	100	10000
97	IRONWORK	100	M ²	100	10000
98	GLASS	100	M ²	100	10000
99	CEILING	100	M ²	100	10000
100	FLOORING	100	M ²	100	10000

Building A (A)

NO.	DESCRIPTION	QTY	UNIT	PRICE	TOTAL
01	FOUNDATION	100	M ³	1500	150000
02	ROOFING	100	M ²	1200	120000
03	WALLS	100	M ²	1800	180000
04	FLOORS	100	M ²	1000	100000
05	DOORS	10	NO.	2000	20000
06	WINDOWS	20	NO.	1500	30000
07	PLASTERING	100	M ²	100	10000
08	PAINTING	100	M ²	100	10000
09	ROOFING	100	M ²	100	10000
10	WOODWORK	100	M ²	100	10000
11	SEWERAGE	100	M	100	10000
12	WATER SUPPLY	100	M	100	10000
13	ELECTRICAL	100	M	100	10000
14	MECHANICAL	100	M	100	10000
15	LANDSCAPING	100	M ²	100	10000
16	CONCRETE	100	M ³	100	10000
17	IRONWORK	100	M ²	100	10000
18	GLASS	100	M ²	100	10000
19	CEILING	100	M ²	100	10000
20	FLOORING	100	M ²	100	10000
21	MECHANICAL	100	M	100	10000
22	ELECTRICAL	100	M	100	10000
23	PLASTERING	100	M ²	100	10000
24	PAINTING	100	M ²	100	10000
25	ROOFING	100	M ²	100	10000
26	WOODWORK	100	M ²	100	10000
27	SEWERAGE	100	M	100	10000
28	WATER SUPPLY	100	M	100	10000
29	ELECTRICAL	100	M	100	10000
30	MECHANICAL	100	M	100	10000
31	LANDSCAPING	100	M ²	100	10000
32	CONCRETE	100	M ³	100	10000
33	IRONWORK	100	M ²	100	10000
34	GLASS	100	M ²	100	10000
35	CEILING	100	M ²	100	10000
36	FLOORING	100	M ²	100	10000
37	MECHANICAL	100	M	100	10000
38	ELECTRICAL	100	M	100	10000
39	PLASTERING	100	M ²	100	10000
40	PAINTING	100	M ²	100	10000
41	ROOFING	100	M ²	100	10000
42	WOODWORK	100	M ²	100	10000
43	SEWERAGE	100	M	100	10000
44	WATER SUPPLY	100	M	100	10000
45	ELECTRICAL	100	M	10	