

SITE PLAN

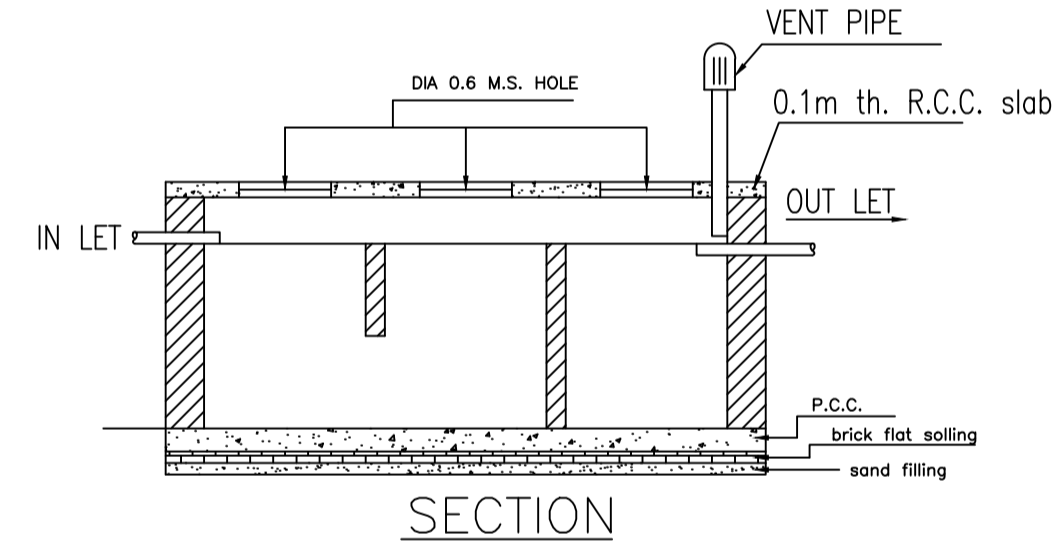

SECTION

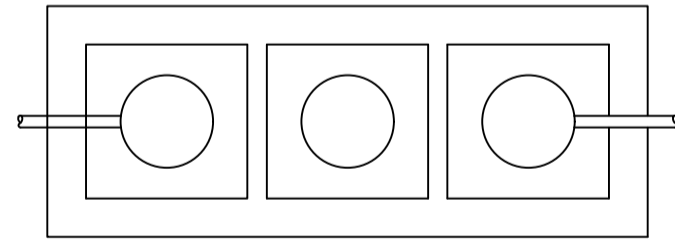

DETAILS OF SEPTIC TANK

SCHEDULE OF DOOR:

BUILDING NAME	NAME	LENGTH	HEIGHT	NOS
A (1)	D3	0.76	2.10	02
A (1)	D2	0.91	2.10	02
A (1)	D1	0.91	2.10	01
A (1)	D1	0.94	2.10	04
A (1)	D1	1.07	2.10	05
A (1)	D3	1.22	2.10	02

SCHEDULE OF WINDOW/VENTILATION:

BUILDING NAME	NAME	LENGTH	HEIGHT	NOS
A (1)	V1	1.00	1.20	04
A (1)	WP	1.60	1.20	02
A (1)	W1	1.80	1.20	16

Building :A (1)

Floor Name	Total Built Up Area (Sq.mt.)	Proposed FAR Area (Sq.mt.)	Total FAR Area (Sq.mt.)	Total Consumed Additional FAR Area (Sq.mt.)	Tnmt (No.)
Ground Floor	102.75	102.75	102.75	102.75	01
First Floor	111.83	111.83	111.83	111.83	00
Terrace Floor	0.00	0.00	0.00	0.00	00
Total :	214.58	214.58	214.58	214.58	01
Total Number of Same Buildings :	1				
Total :	214.58	214.58	214.58	214.58	01

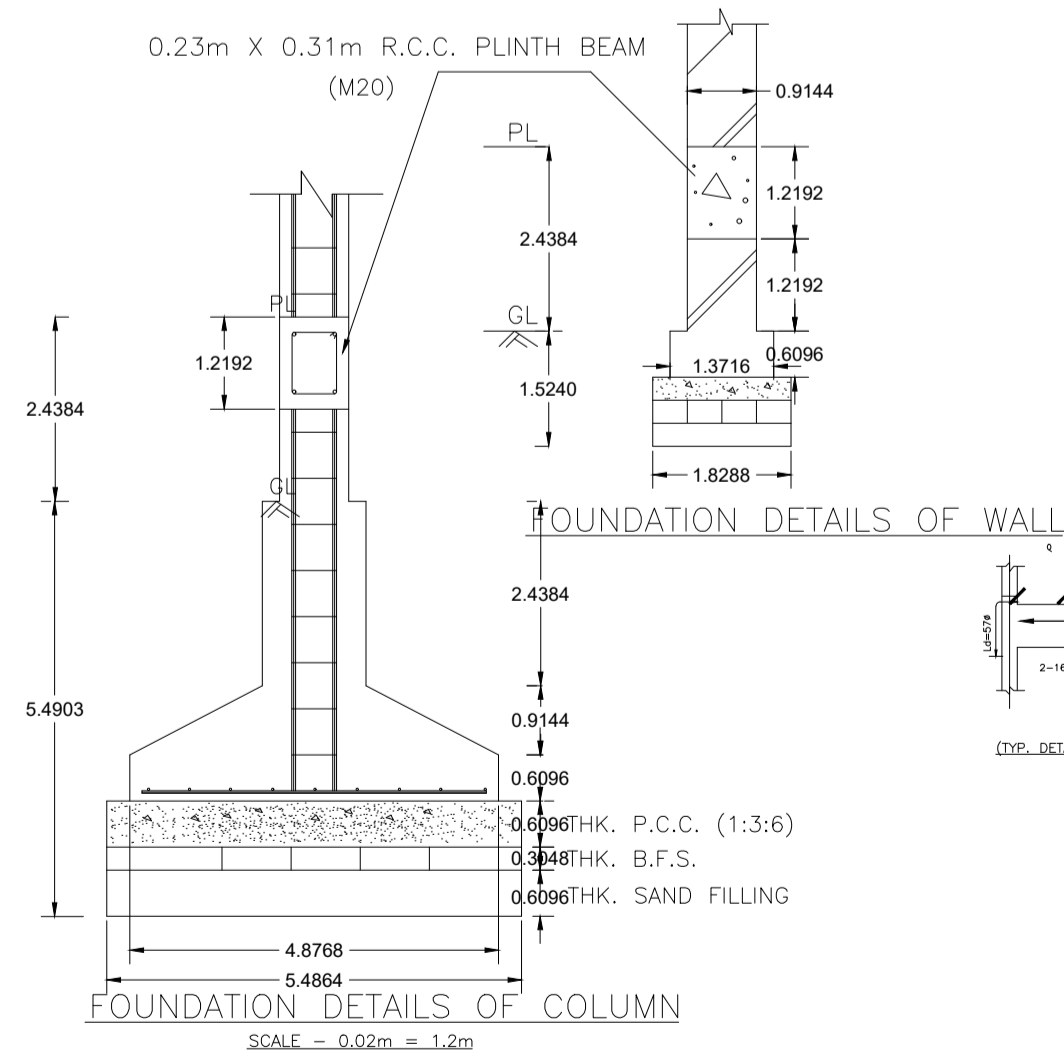

FOUNDATION DETAILS OF COLUMN

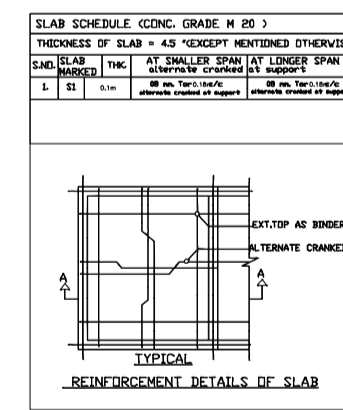

REINFORCEMENT DETAILS OF SLAB

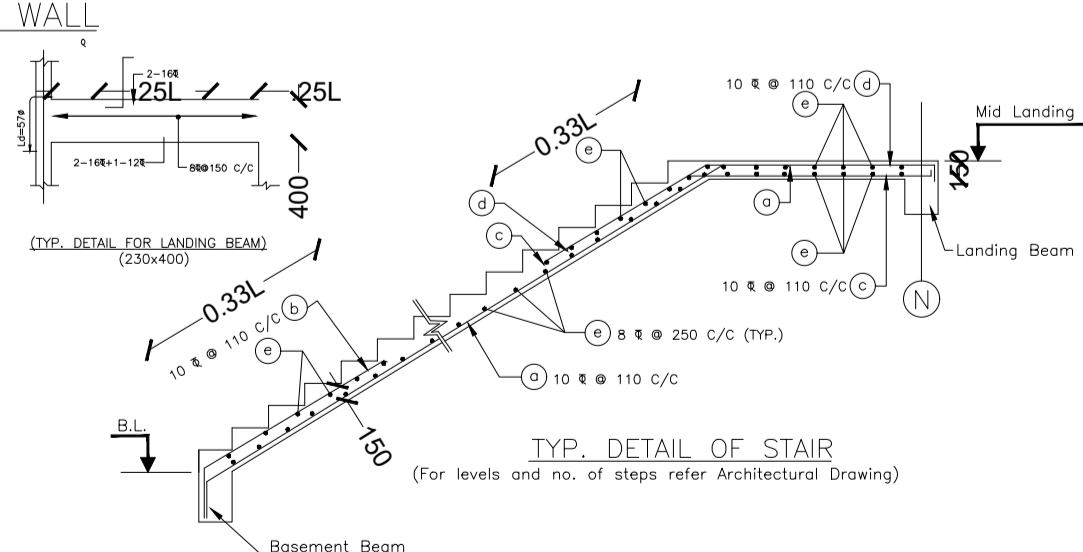

TYP. DETAIL OF STAIR

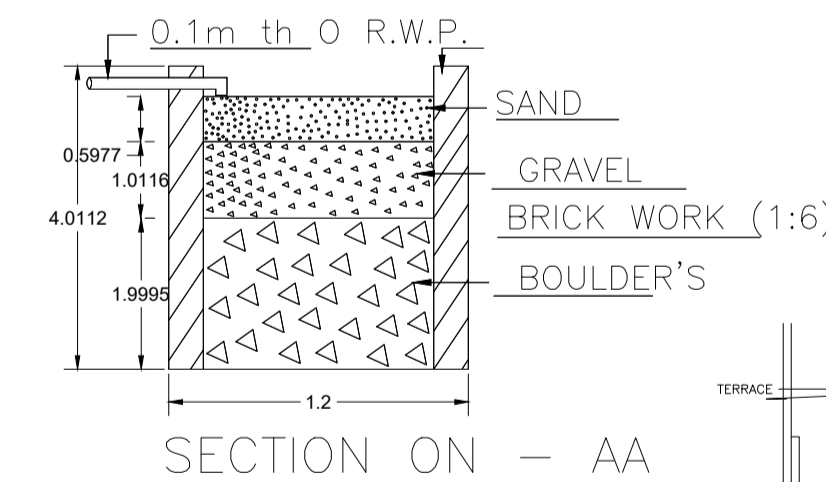

SECTION ON - AA

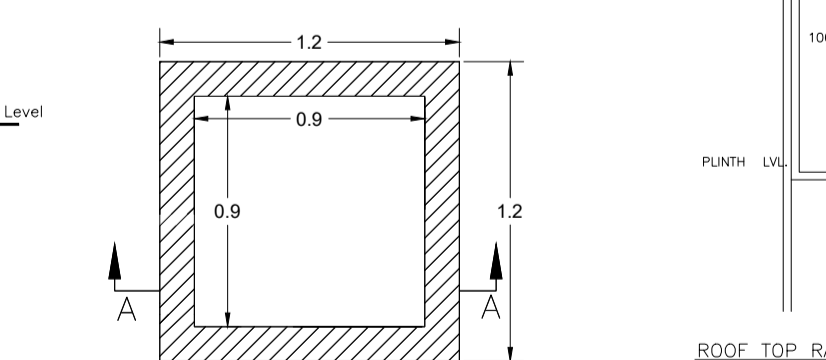

DETAIL'S OF WATER HARVESTING

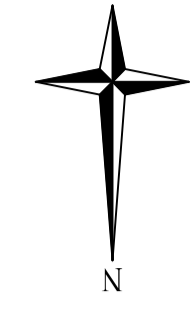
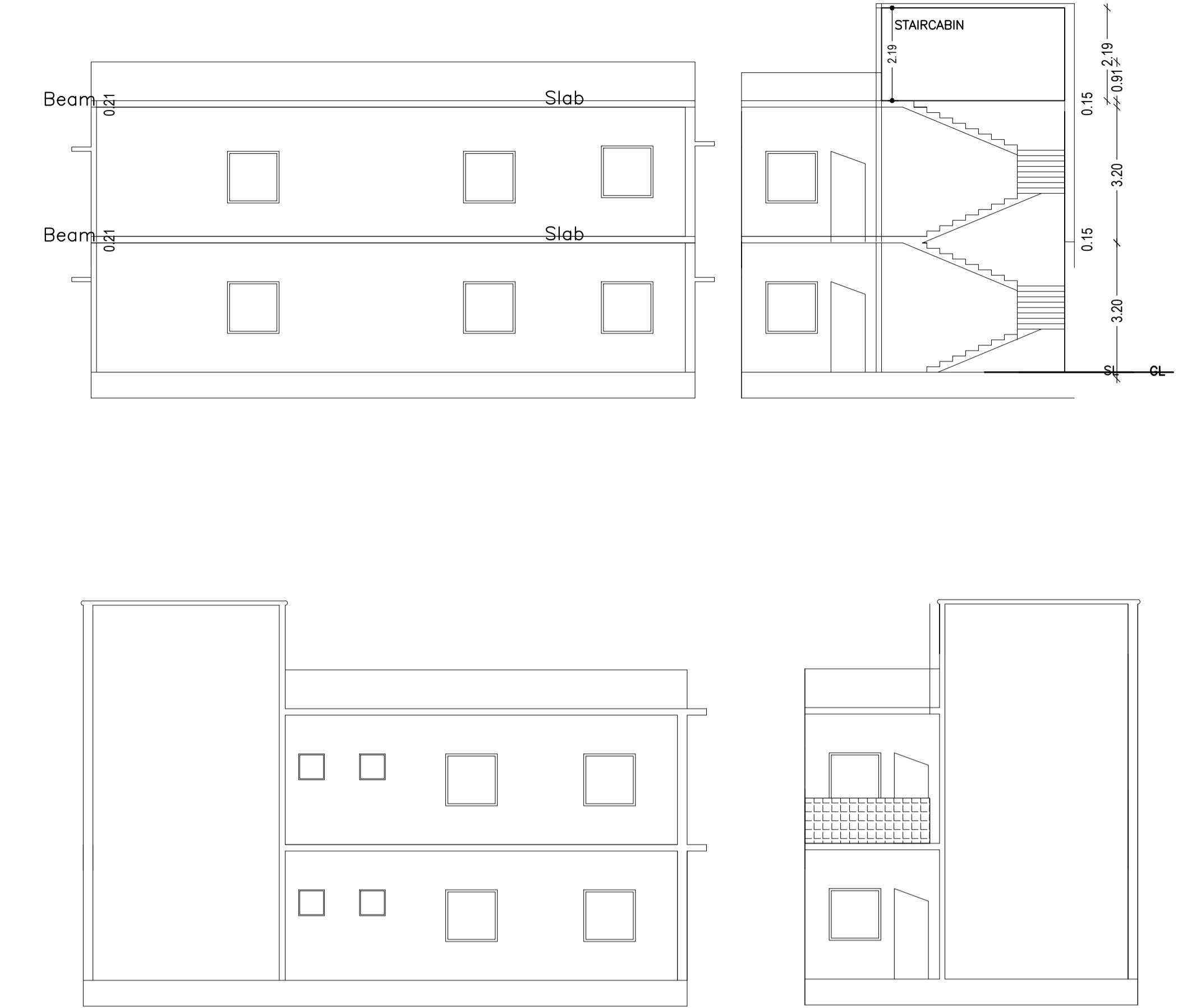

Proposal Basic Information

Proposal File No.	DMC/BP/0349/W20/2023
Owner Name	Aaditya Kumar
Khata No	29 ( New 171)
Plot No	458 ( NEW 855)
Village Name	Bisanpur
Use	Residential
SubUse	Bungalow/ Dwelling / Non Apartment

AREA STATEMENT

AREA OF PLOT (Minimum)	(A)	SQ.MT.
NET AREA OF PLOT(Gross Plot Area - Deduction from Gross Plot area)	(A-Deductions)	167.16
Deduction for Balance Plot Area(from Gross Plot Area)		
Common Plot		12.50
Total		12.50
BALANCE AREA OF PLOT (Net Plot Area - Recreational/Amenity space)	(A-Deductions)	154.66
PLOT AREA FOR COVERAGE(Net Plot Area)	(A-Deductions)	167.16
Plot Area for FAR (Net Plot Area + RoadWidening Area)	(A-Deductions)	167.16

COVERAGE CHECK

Permissible Coverage area ( 70.00 % )	117.01
Proposed Coverage Area ( 61.47 % )	102.75
Total Prop. Coverage Area ( 61.47 % )	102.75
Balance coverage area ( 8.53 % )	14.26

FAR CHECK

Perm. FAR Area ( 1.500 )	250.74
Total Perm. FAR area	250.74
Residential FAR	214.58
Proposed FAR Area	214.58
Total Proposed FAR Area	214.58
Consumed FAR (Factor)	1.28
Balance FAR Area	36.16

BUILT UP AREA CHECK

Total Proposed BuiltUp Area	214.58
-----------------------------	--------

ARCHITECT (Regd) SUSHIL KUMAR  
ENGINEER (Regd)  
SUPERVISOR (Regd)  
OWNER (Regd) Aaditya Kumar

DEVELOPMENT AUTHORITY LOCAL BODY

COLOR INDEX

PLOT BOUNDARY	Black
ABUTTING ROAD	Green
PROPOSED CONSTRUCTION	Red
COMMON PLOT	Yellow
ROAD WIDENING AREA	Blue
EXISTING (To be retained)	Light Blue
EXISTING (To be demolished)	Dark Blue

Buildingwise Floor FAR Details

Floor Name	Building Name A (1)		Total	
	Proposed Built Up Area (Sq.mt.)	Proposed FAR Area (Sq.mt.)	Total Proposed Built Up Area (Sq.mt.)	Total FAR Area (Sq.mt.)
Ground Floor	102.75	102.75	102.75	102.75
First Floor	111.83	111.83	111.83	111.83
Terrace Floor	0.00	0.00	0.00	0.00
Total :	214.58	214.58	214.58	214.58

Building USE/SUBUSE Details

Building Name	Building Use	Building SubUse	Building Structure
A (1)	Residential	Bungalow/ Dwelling / Non Apartment	Non-Highrise

UnitBUA Table for Building :A (1)

FLOOR	Name	UnitBUA Type	UnitBUA Area	Carpet Area	No. of Rooms	No. of Tenement
GROUND FLOOR PLAN	SPLIT 1	FLAT	214.58	214.46	7	1
FIRST FLOOR PLAN	SPLIT 1	FLAT	0.00	0.00	8	0
Total:	-	-	214.58	214.46	15	1

FAR & Tenement Details (Table 4c-1)

Building	No. of Same Bldg	Total Built Up Area (Sq.mt.)	Proposed FAR Area (Sq.mt.) Resi.	Total FAR Area (Sq.mt.)	Total Consumed Additional FAR Area (Sq.mt.)	Tnmt (No.)
A (1)	1	214.58	214.58	214.58	214.58	01
Grand Total :	1	214.58	214.58	214.58	214.58	01

LTP NAME AND SIGNATURE	STRUCTURAL ENG'S NAME AND SIGNATURE	BUILDER NAME AND SIGNATURE	DIGITAL SIGNATURE
SUSHIL KUMAR DMC/ENG/0005/2016			

