

SITE PLAN

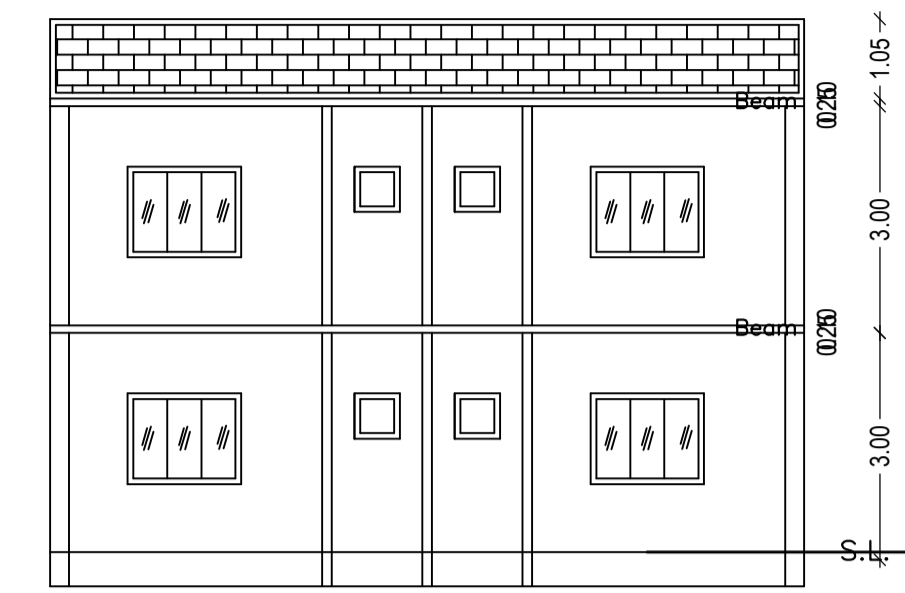

SECTION ON X-X

SECTION ON Y-Y

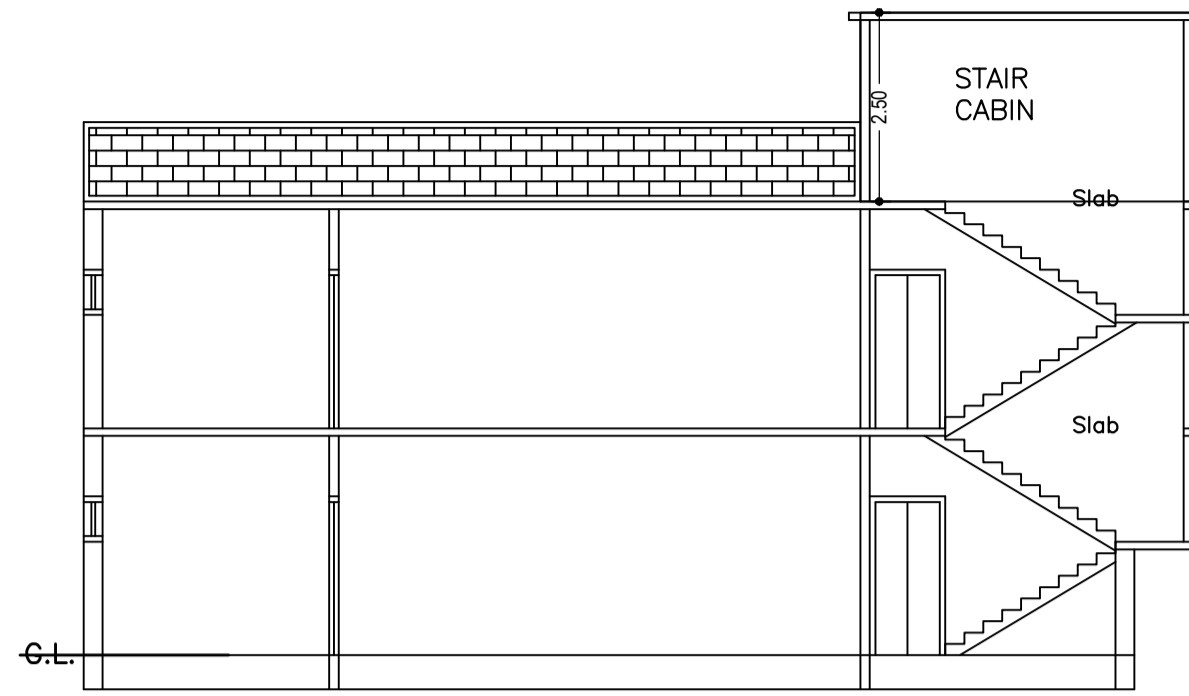
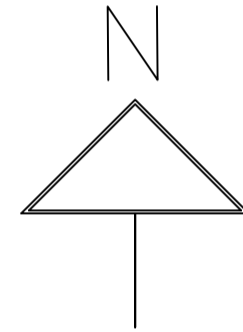
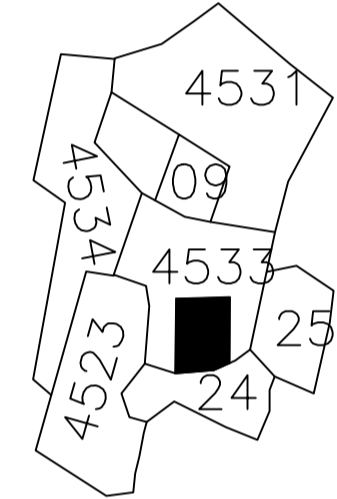
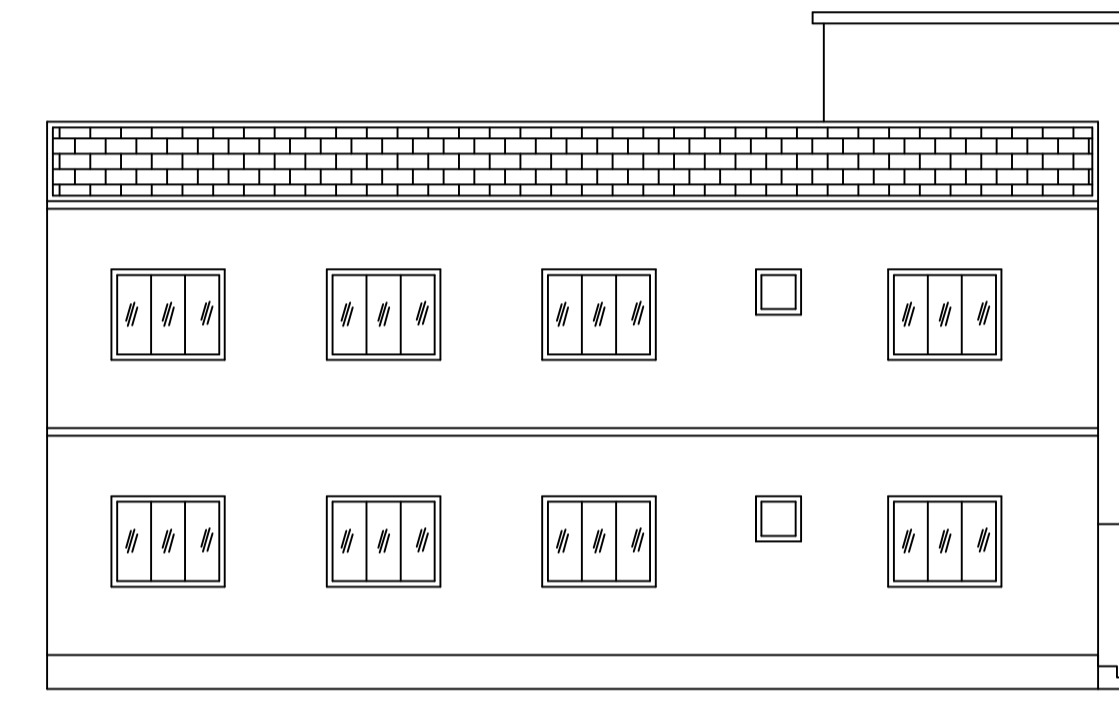
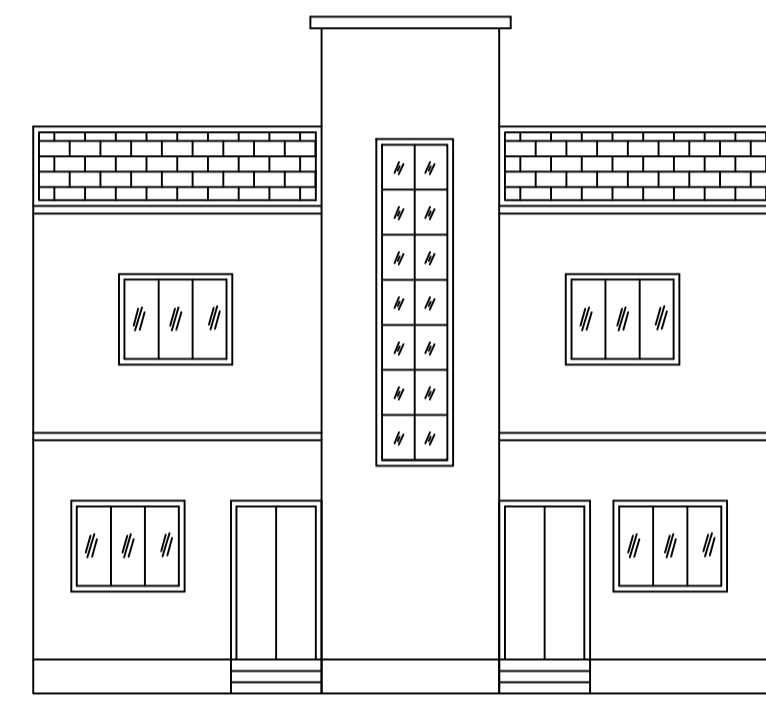

FRONT ELEVATION

LEFT SIDE ELEVATION

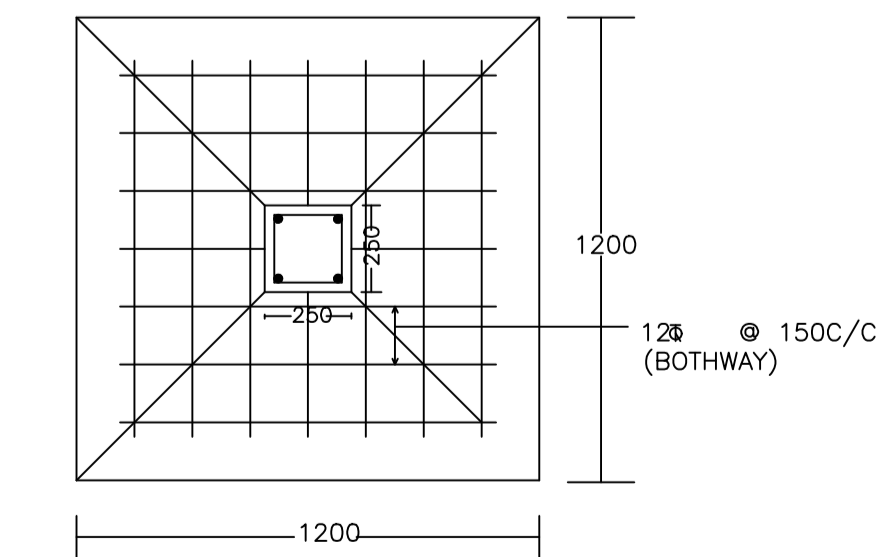
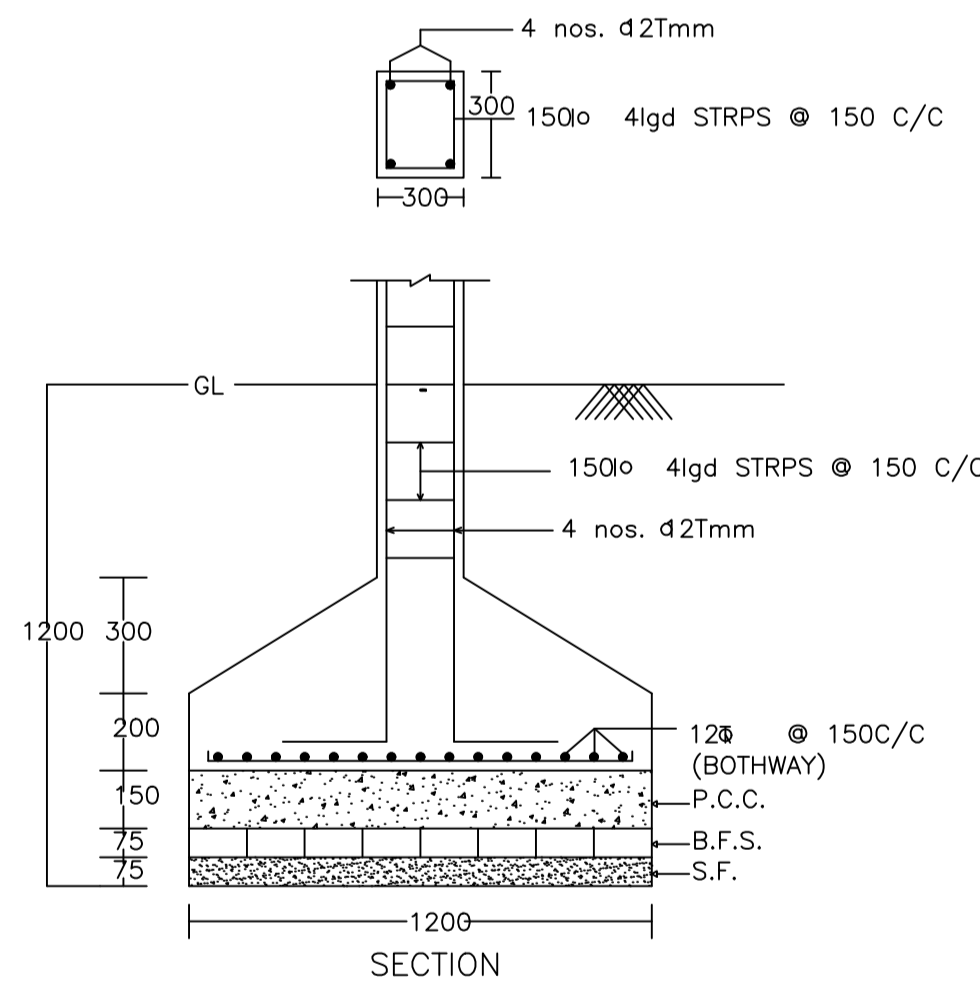

DETAIL OF COLUMNS

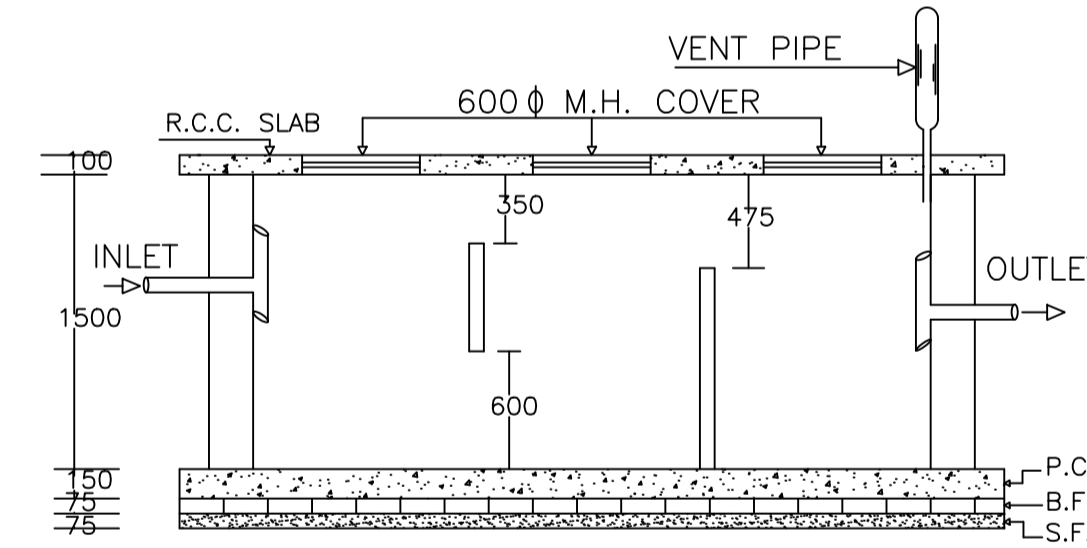

PLAN OF SEPTIC TANK

UnitBUA Table for Building :AA (AA)

FLOOR	Name	UnitBUA Type	UnitBUA Area	Carpet Area	No. of Rooms	No. of Tenement
GROUND FLOOR PLAN	SPLIT AA	FLAT	280.95	280.88	14	1
FIRST FLOOR PLAN	SPLIT AA	FLAT	0.00	0.00	14	0
Total:	-	-	280.95	280.88	28	1

SCHEDULE OF DOOR:

BUILDING NAME	NAME	LENGTH	HEIGHT	NOS
AA (AA)	D	0.90	2.10	08
AA (AA)	D	1.00	2.10	04
AA (AA)	D	1.05	2.10	08
AA (AA)	D	1.20	2.10	06

SCHEDULE OF WINDOW/VENTILATION:

BUILDING NAME	NAME	LENGTH	HEIGHT	NOS
AA (AA)	W	0.60	1.20	08
AA (AA)	W	0.90	1.20	02
AA (AA)	W	1.80	1.20	24

Building :AA (AA)

Floor Name	Total Built Up Area (Sq.mt.)	Proposed FAR Area (Sq.mt.) Res.	Total FAR Area (Sq.mt.)	Total Consumed Additional FAR Area (Sq.mt.)	Trmt (No.)
Ground Floor	140.47	140.47	140.47	140.47	01
First Floor	140.47	140.47	140.47	140.47	00
Terrace Floor	0.00	0.00	0.00	0.00	00
Total :	280.94	280.94	280.94	280.94	01
Total Number of Same Buildings	1				
Total :	280.94	280.94	280.94	280.94	01

Proposal Basic Information

Proposal File No.	DMC/EP/0298/W23/2023
Owner Name	SMT. SUMITRA DEVI
Khata No	94,95(OLD), 256(NEW)
Plot No	3573,3575,3576(OLD), 4533(NEW)
Village Name	Kolakusma
Use	Residential
SubUse	Bungalow/ Dwelling / Non Apartment

AREA STATEMENT  
DHANBAD MUNICIPAL CORPORATION

VERSION NO. : 1.0.67  
VERSION DATE: 16/10/2020

PROJECT DETAIL:	Plot Use: Residential	SQ. MT.
Region: JHARKHAND URBAN	Plot SubUse: Bungalow/ Dwelling / Non Apartment	291.30
Local Bodies: DHANBAD	Plot Nearby/Religious Structure: NA	5.69
Authority: DHANBAD MUNICIPAL CORPORATION	Plot No: 3573,3575,3576(OLD), 4533(NEW)	285.61
Inward No: DMC/EP/0298/W23/2023	North: Road Width - 4.26 WIDE ROAD	22.72
Application Type: General Proposal	South: Plot No. - RINKU PAL NEW PLOT NO- 4524	28.41
Project Type: Building Proposal	East: Plot No. - PIMKY DEVI NEW PART OF PLOT NO- 4533	262.89
Nature of Development: New	West: Plot No. - RAMESH SINGH PART OF THIS PLOT	285.61
Location of Development Area: Old Area		291.30
AREA DETAILS:		
AREA OF PLOT (Minimum)	(A)	291.30
Deduction for NetPlot Area		5.69
Surinder Free of Cost		5.69
NET AREA OF PLOT (Gross Plot Area - Deduction from Gross Plot area)	(A-Deductions)	285.61
Deduction for Balance Plot Area (from Gross Plot Area)		5.69
Surinder Free of Cost		22.72
Common Plot		28.41
BALANCE AREA OF PLOT (Net Plot Area - Recreational/Amenity space)	(A-Deductions)	262.89
PLOT AREA FOR COVERAGE (Net Plot Area)	(A-Deductions)	285.61
Plot Area for FAR (Net Plot Area + Road Widening Area)	(A-Deductions)	291.30
COVERAGE CHECK		
Permissible Coverage area ( 60.00 % )		171.37
Proposed Coverage Area ( 49.18 % )		140.47
Total Prop. Coverage Area ( 49.18 % )		140.47
Balance coverage area ( 10.82 % )		30.90
FAR CHECK		
Perm. FAR Area ( 1.500 )		436.95
Total Perm. FAR area		436.95
Residential FAR		280.95
Proposed FAR Area		280.95
Total Proposed FAR Area		280.95
Consumed FAR (Factor)		0.96
Balance FAR Area		156.00
BUILT UP AREA CHECK		
Total Proposed BuiltUp Area		280.94
ARCHITECT (Regd)		AJAY KUMAR KESARI
ENGINEER (Regd)		
SUPERVISOR (Regd)		
OWNER (Regd)		SMT. SUMITRA DEVI
DEVELOPMENT AUTHORITY		LOCAL BODY

COLOR INDEX

PLOT BOUNDARY	Black
ABUTTING ROAD	Red
PROPOSED CONSTRUCTION	Green
COMMON PLOT	Yellow
ROAD WIDENING AREA	Blue
EXISTING (To be retained)	Orange
EXISTING (To be demolished)	Purple

Buildingwise Floor FAR Details

Floor Name	Building Name AA (AA)		Total	
	Proposed Built Up Area (Sq.mt.)	Proposed FAR Area (Sq.mt.)	Total Proposed Built Up Area (Sq.mt.)	Total FAR Area (Sq.mt.)
Ground Floor	140.47	140.47	140.47	140.47
First Floor	140.47	140.47	140.47	140.47
Terrace Floor	0.00	0.00	0.00	0.00
Total :	280.94	280.94	280.94	280.94

Building USE/SUBUSE Details

Building Name	Building Use	Building SubUse	Building Structure
AA (AA)	Residential	Bungalow/ Dwelling / Non Apartment	Non-Highrise

FAR & Tenement Details (Table 4c-1)

Building	No. of Same Bldg	Total Built Up Area (Sq.mt.)	Proposed FAR Area (Sq.mt.) Res.	Total FAR Area (Sq.mt.)	Total Consumed Additional FAR Area (Sq.mt.)	Trmt (No.)
AA (AA)	1	280.94	280.94	280.94	280.94	01
Grand Total :	1	280.94	280.94	280.94	280.94	01

LTP NAME AND SIGNATURE AJAY KUMAR KESARI DMC/ENG/0007/2021	STRUCTURAL ENG'S NAME AND SIGNATURE	BUILDER NAME AND SIGNATURE	DIGITAL SIGNATURE
--	-------------------------------------	----------------------------	-------------------

Proposal Basic Information	
Proposal File No.	DMC/EP/0298/W23/2023
Owner Name	SMT. SUMITRA DEVI
Khata No	94,95(OLD), 256(NEW)
Plot No	3573,3575,3576(OLD), 4533(NEW)
Village Name	Kolakusma
Use	Residential
SubUse	Bungalow/ Dwelling / Non Apartment

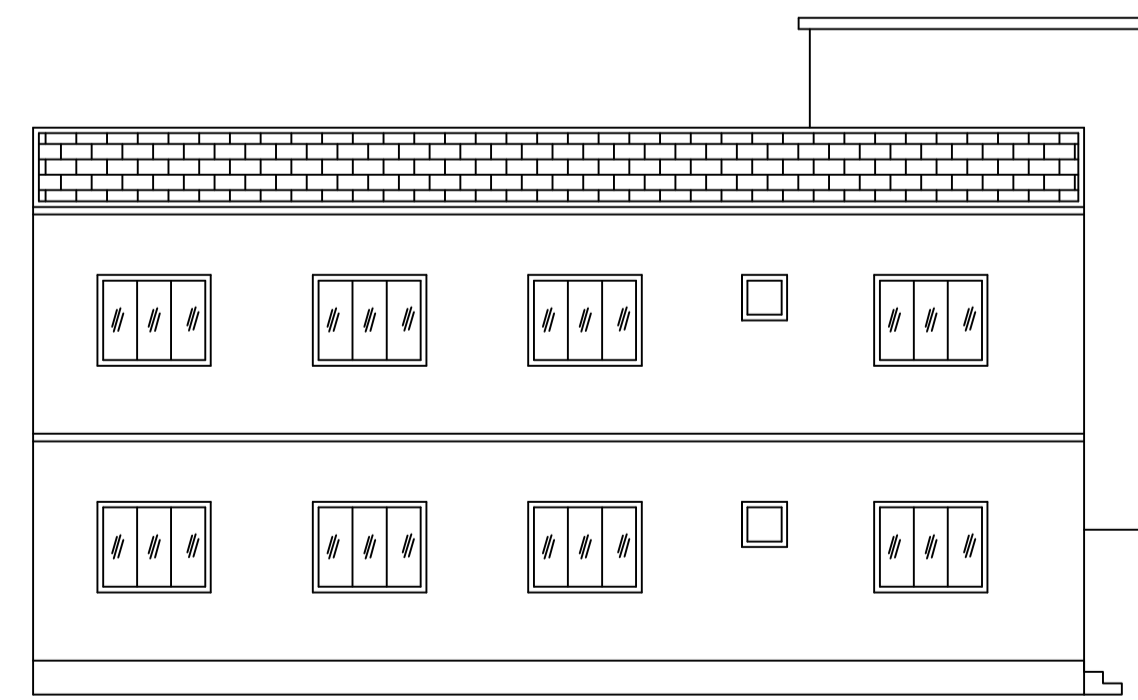
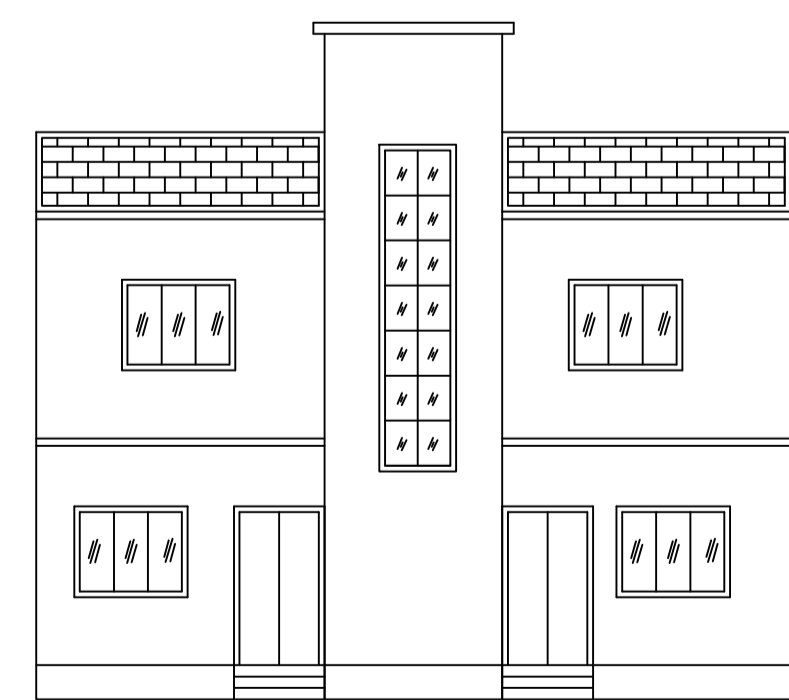
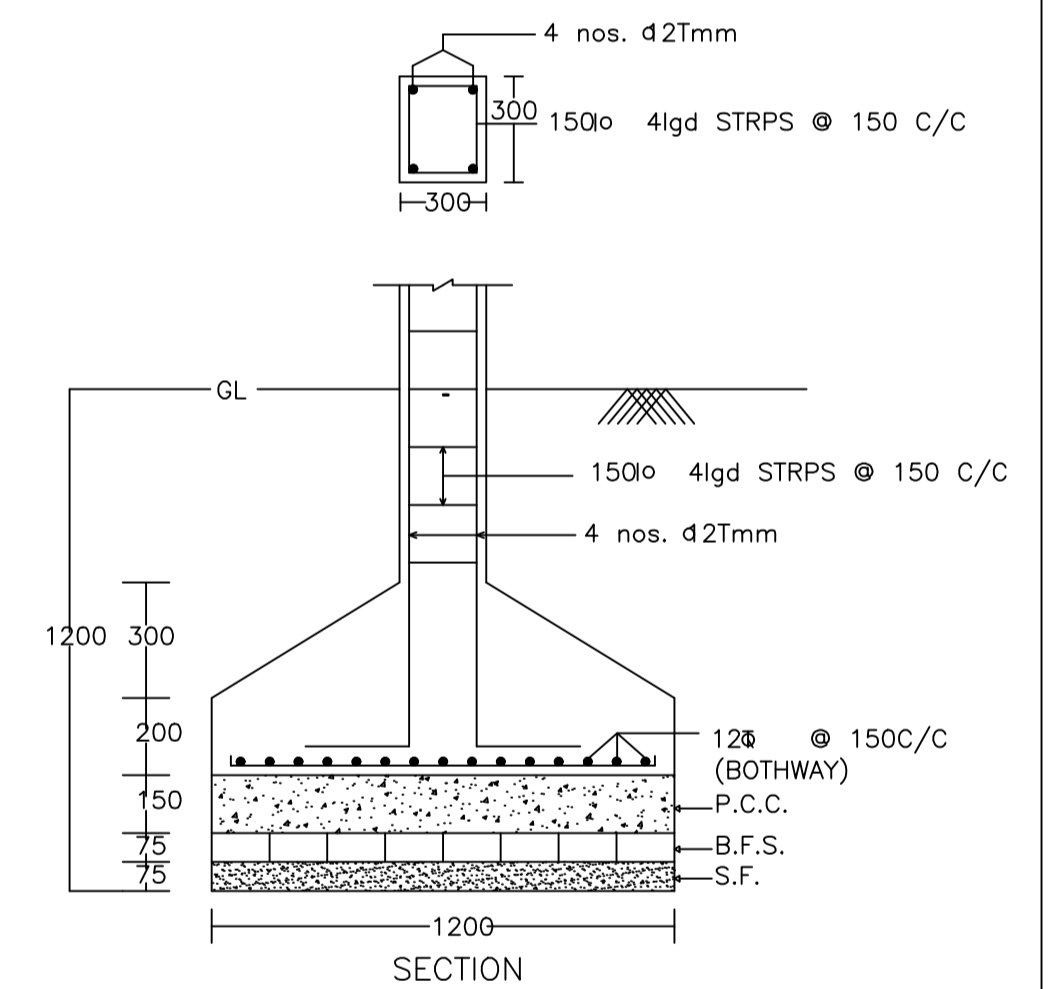
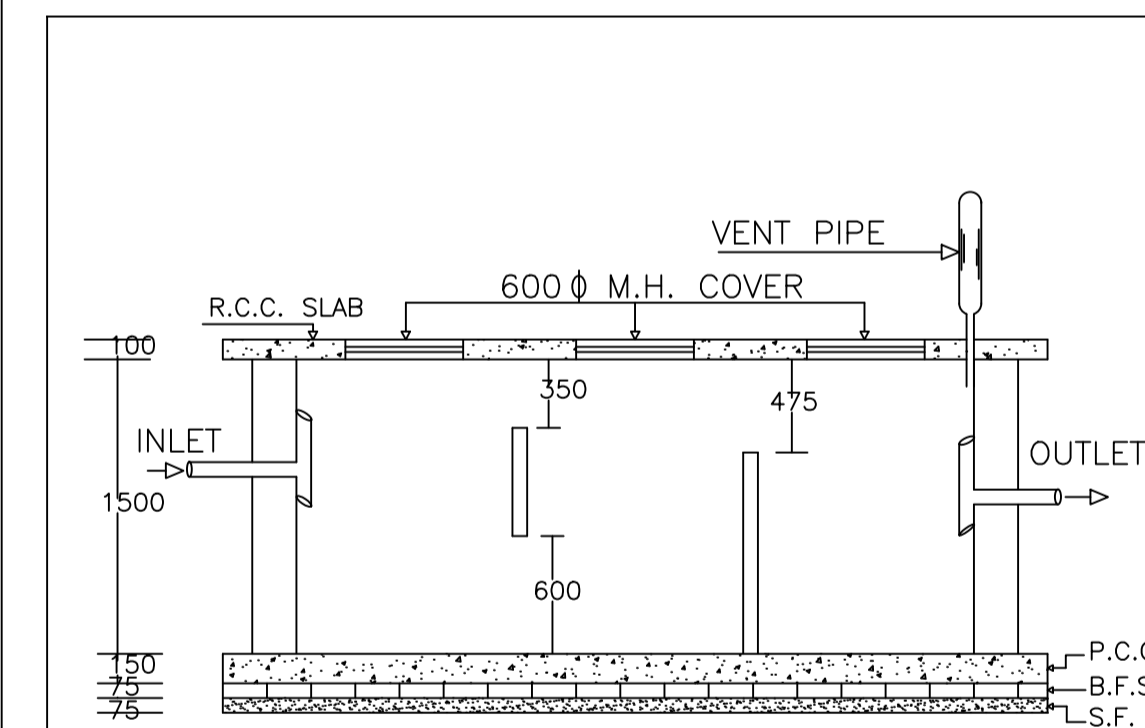
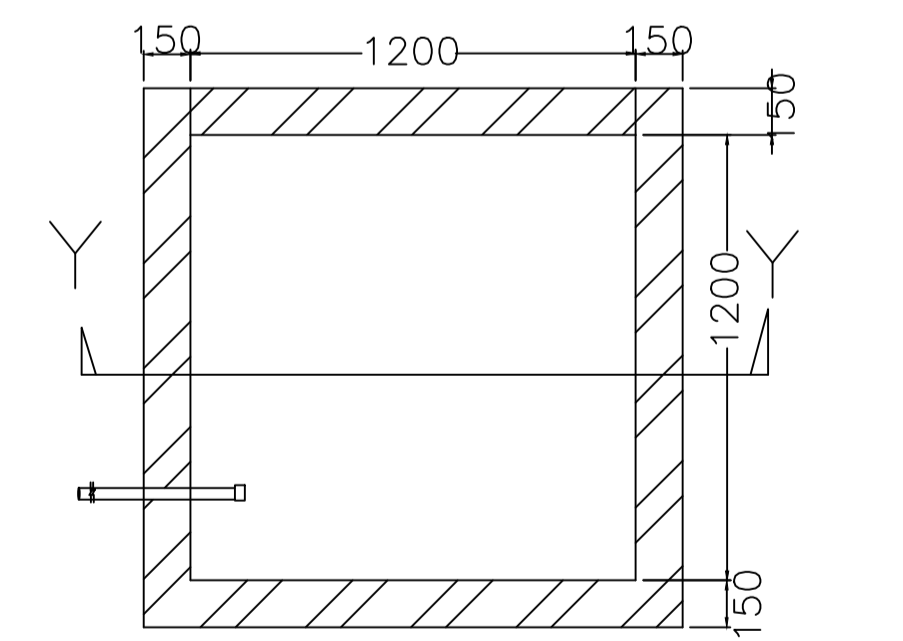
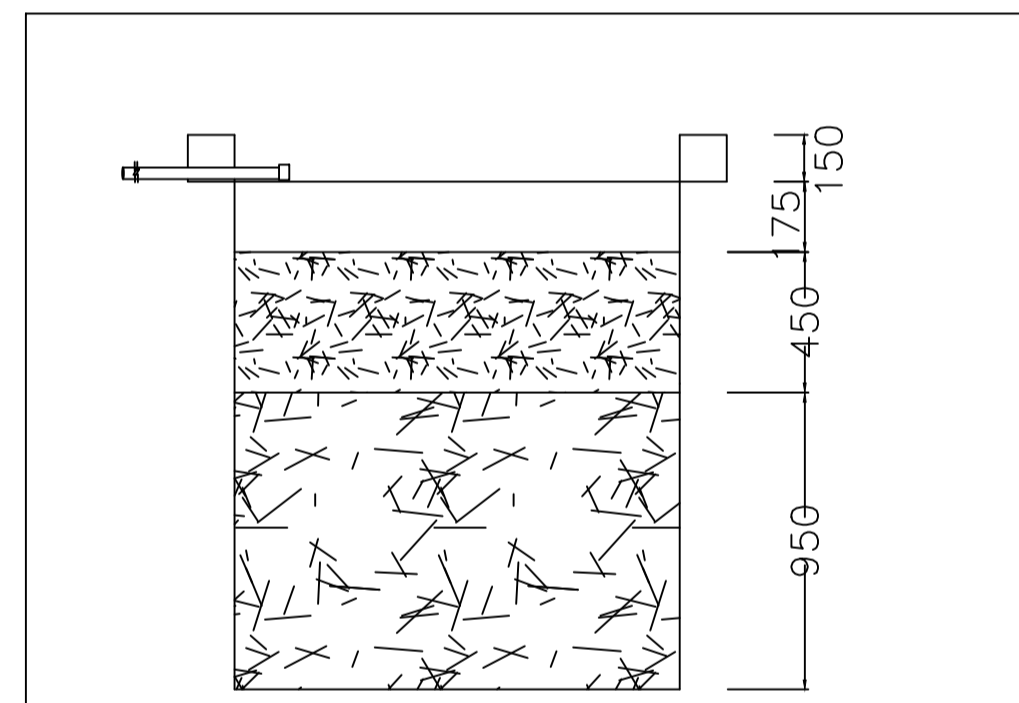
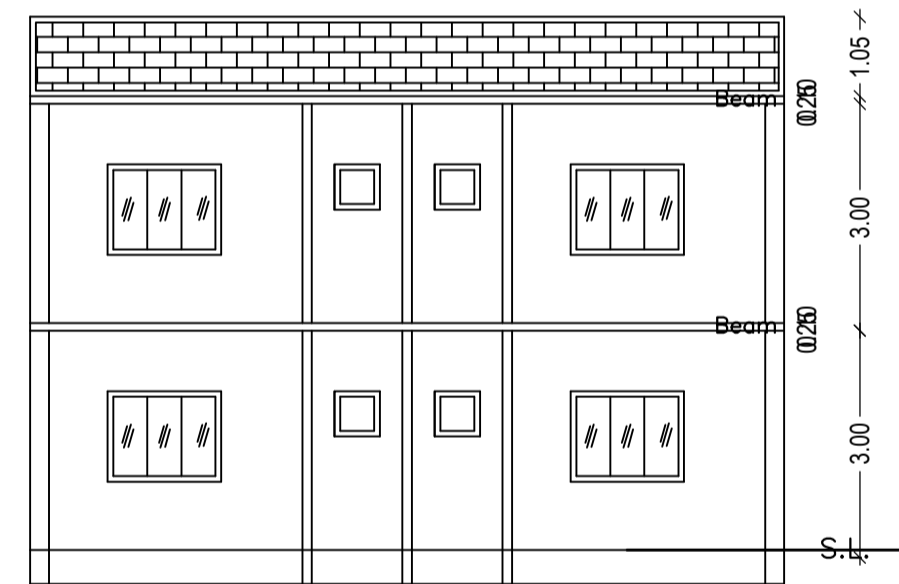
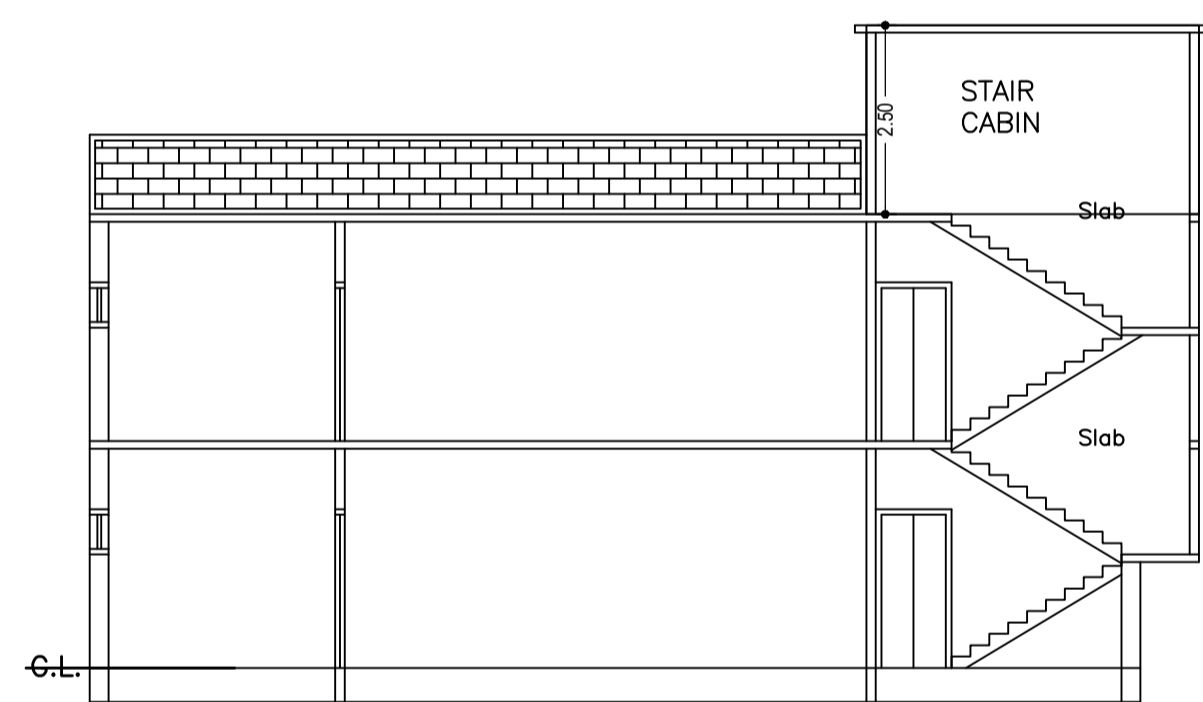
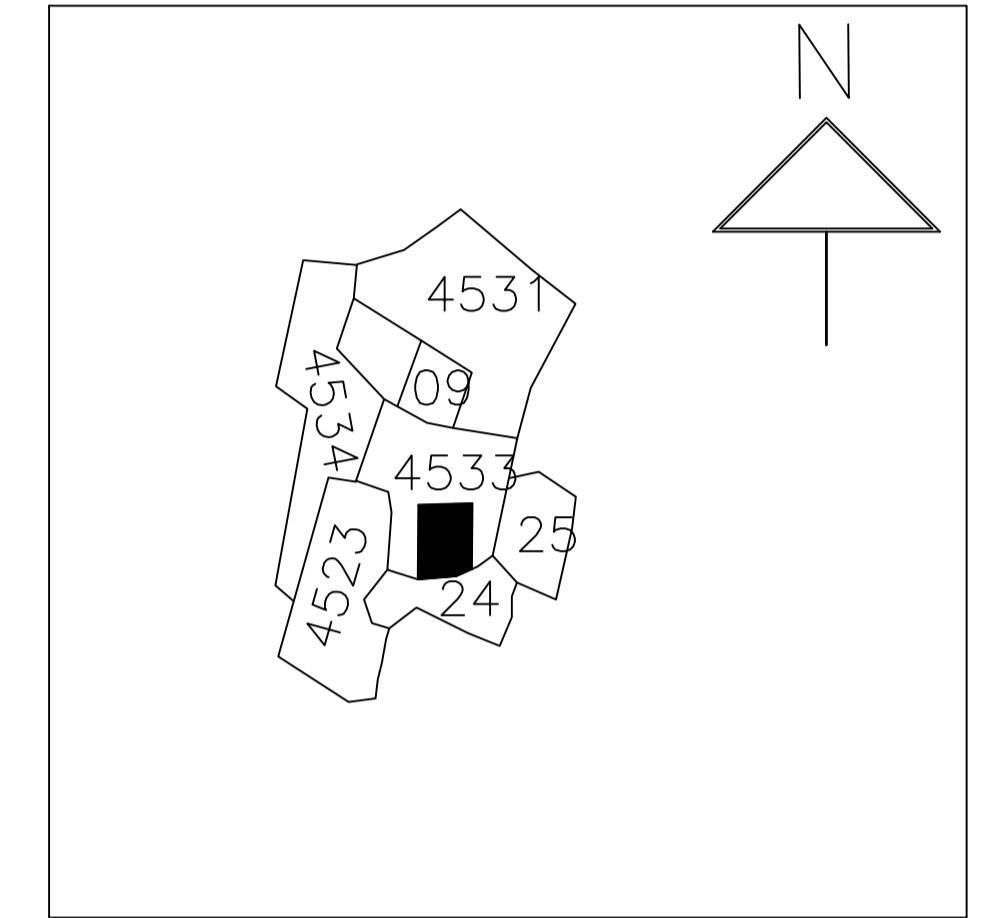
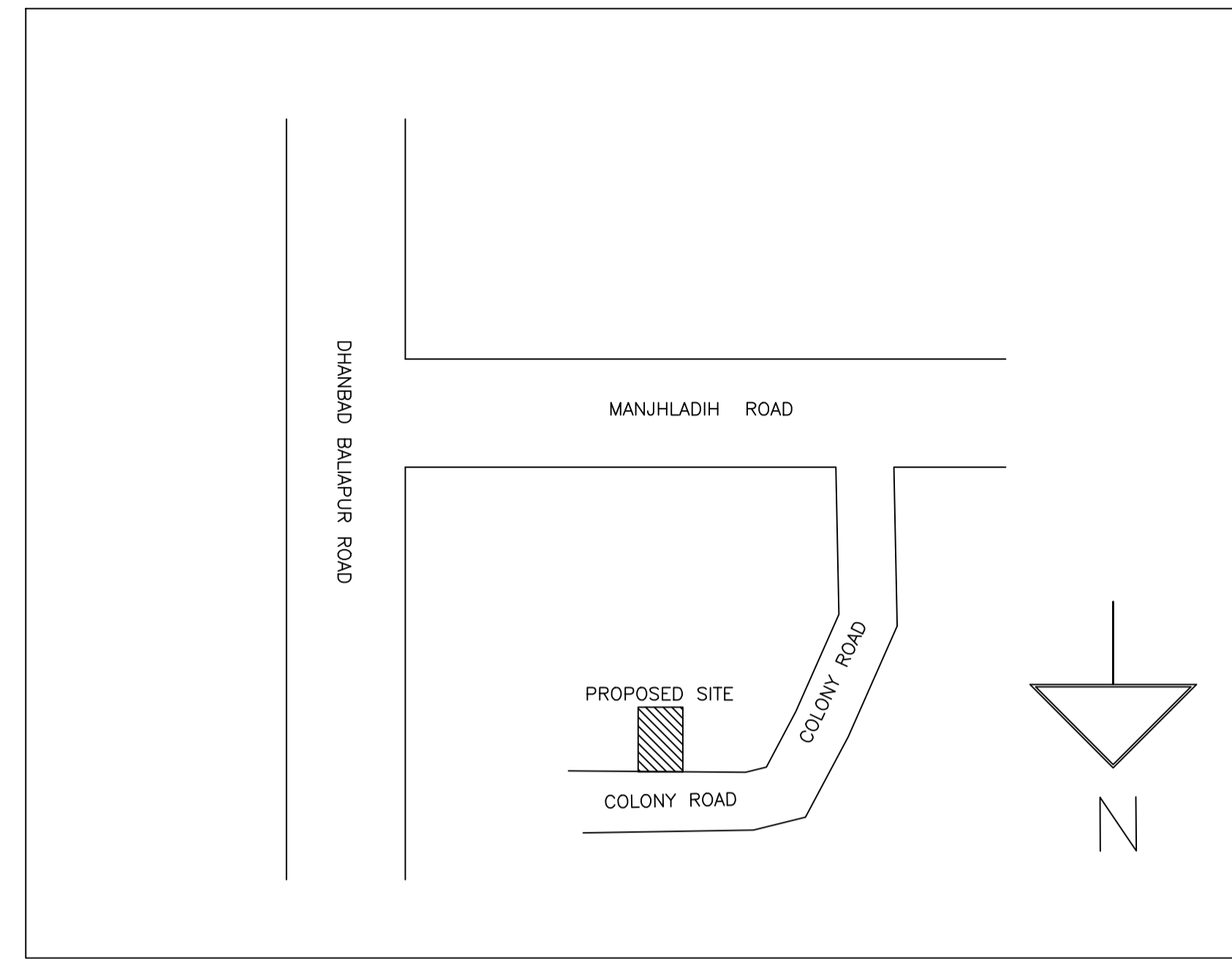
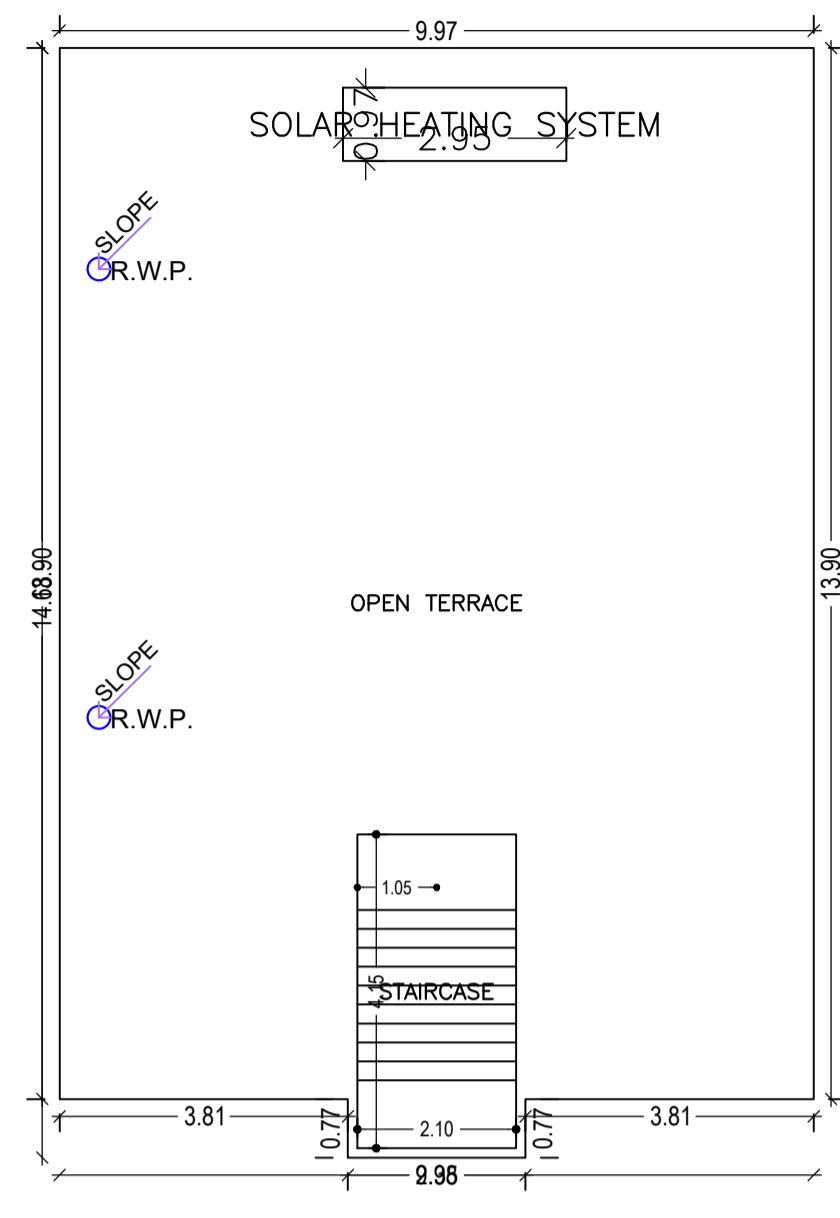
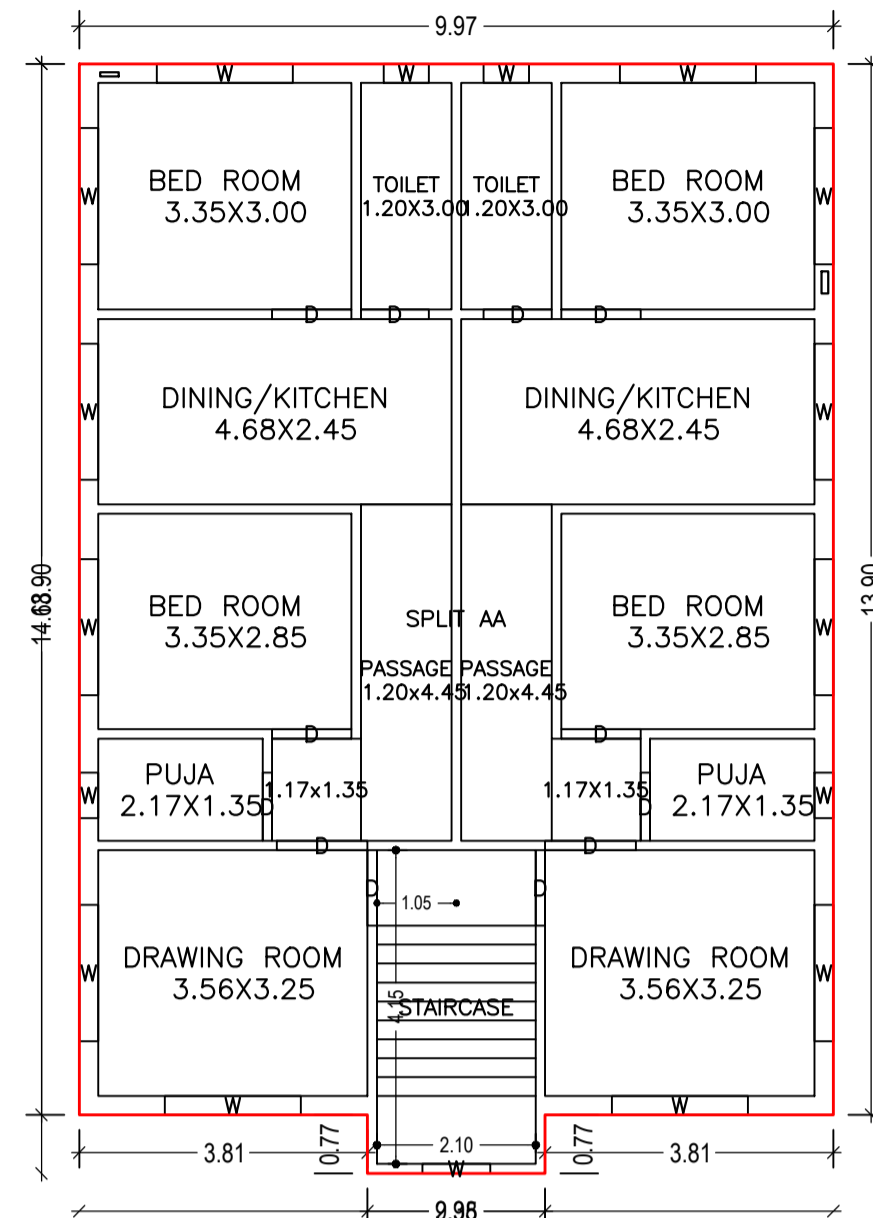
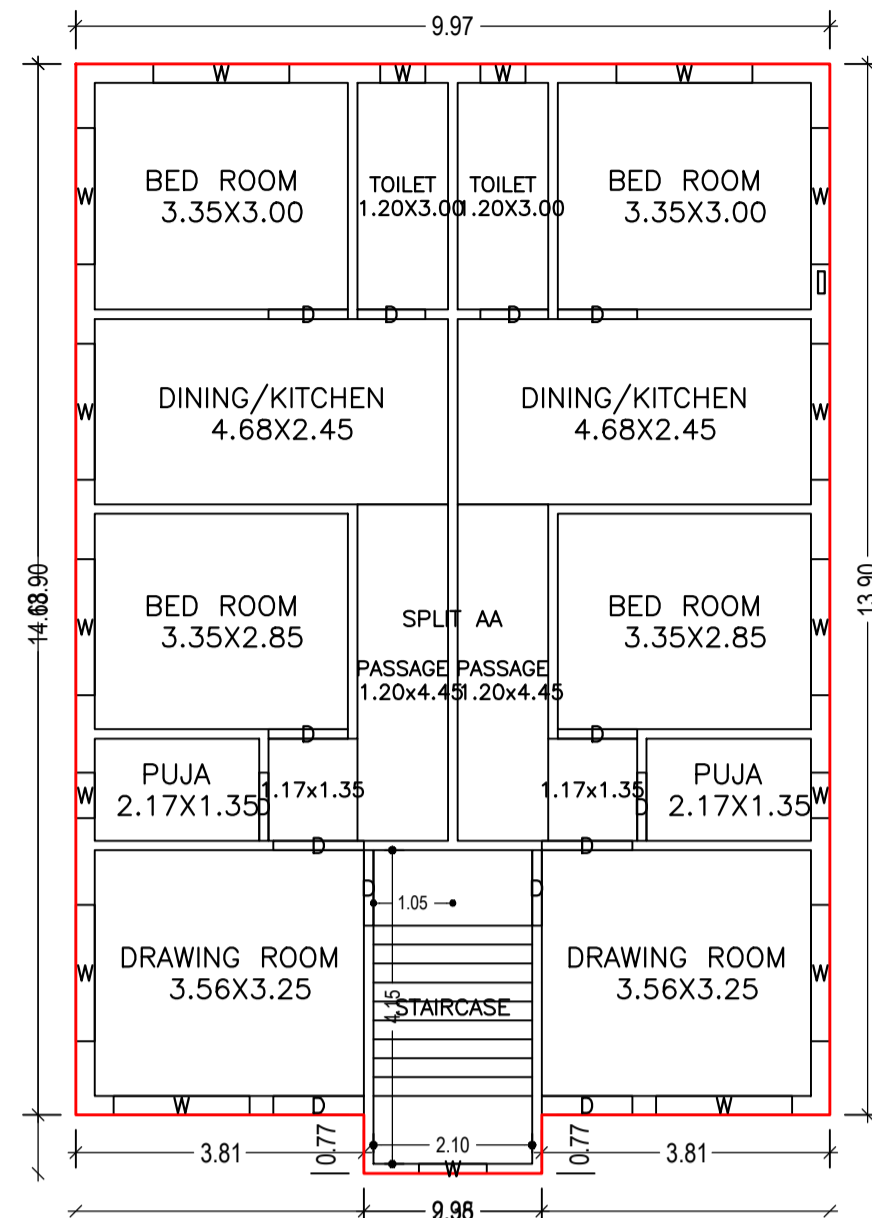

LTP NAME AND SIGNATURE	STRUCTURAL ENG'S NAME AND SIGNATURE	BUILDER NAME AND SIGNATURE	DIGITAL SIGNATURE
AJAY KUMAR KESARI DMC/ENG/0007/2021			