

Proposal Basic Information

Proposal File No.	DMC/BP/0299/W22/2023
Owner Name	SANJU DEVI
Khata No	977(N)/136(O)
Plot No	218 (O) / 829(N)
Village Name	Saraidhela
Use	Residential
SubUse	Bungalow/ Dwelling / Non Apartment

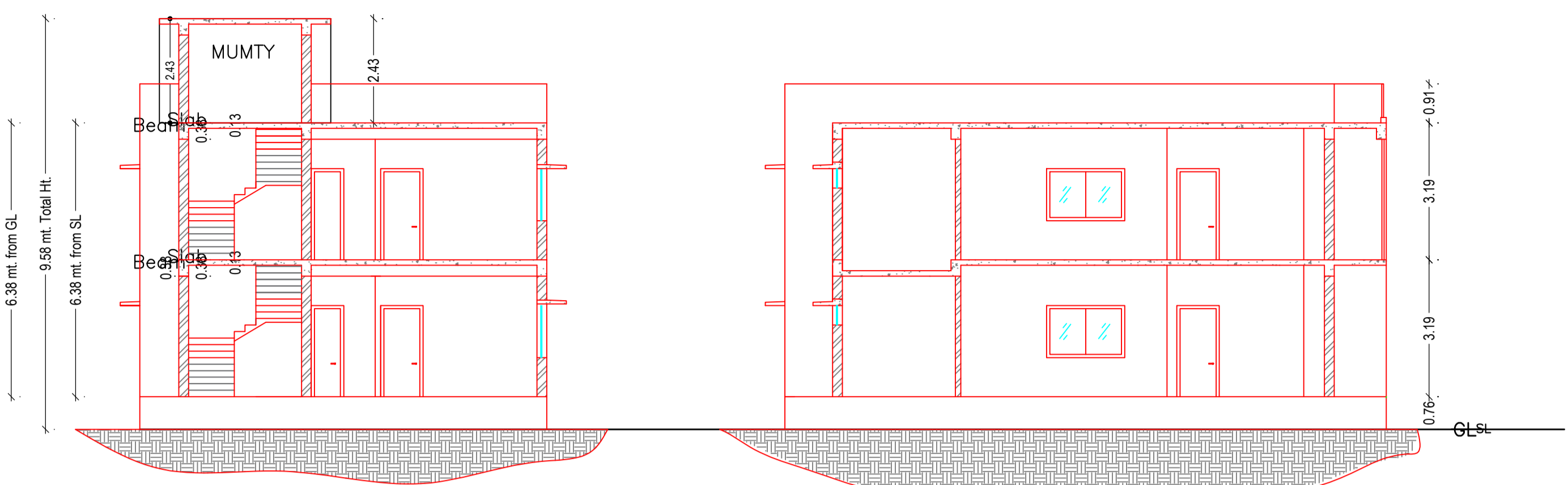
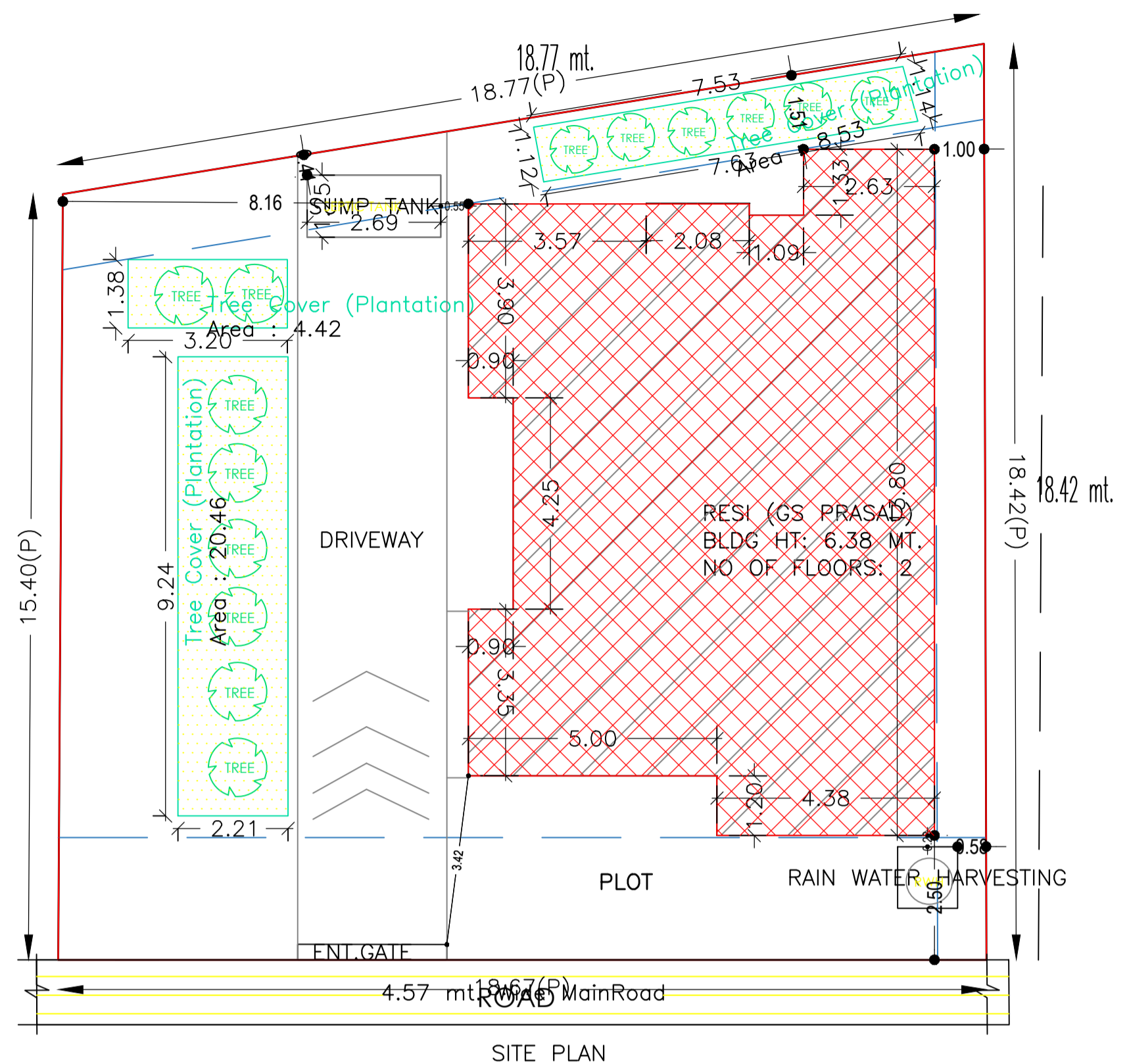

SECTION - XX

SECTION - YY

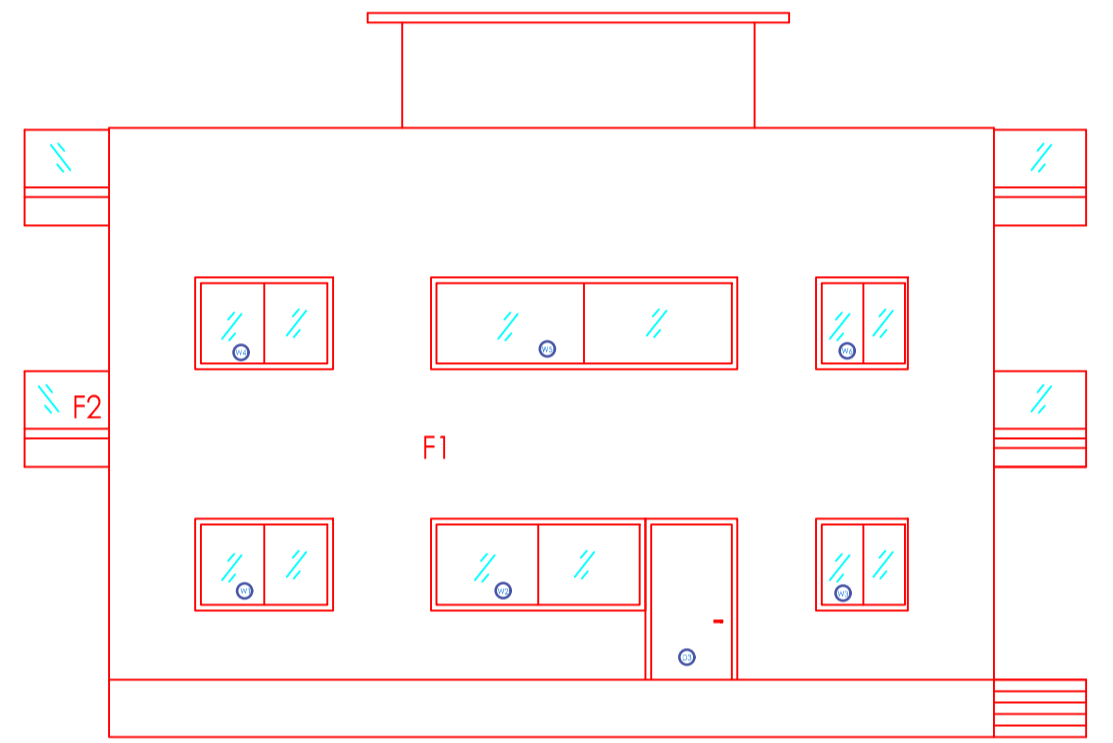
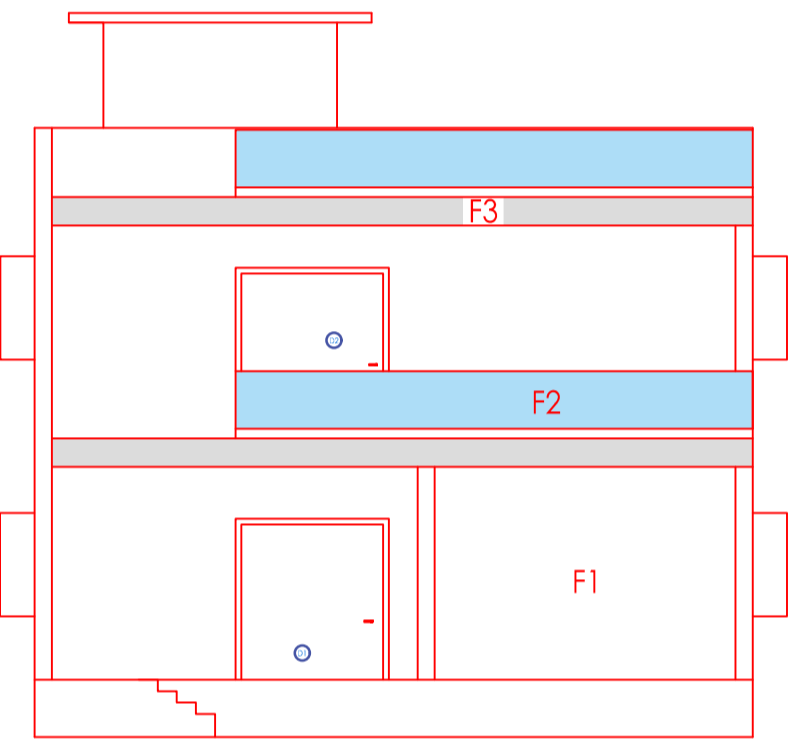

FRONT ELEVATION

SIDE ELEVATION

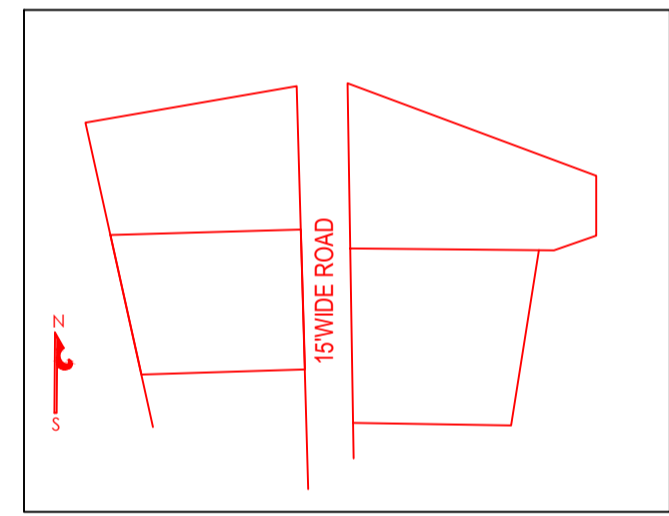
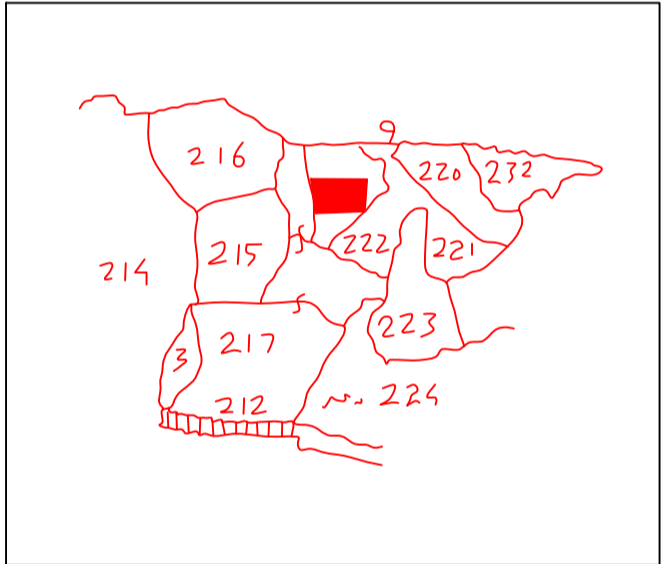

AREA STATEMENT	VERSION NO.: 1.0.66	
DHANBAD MUNICIPAL CORPORATION	VERSION DATE: 16/10/2020	
<b>PROJECT DETAIL:</b>		
Region: JHARKHAND URBAN LOCAL BODIES	Plot Use: Residential	
District: DHANBAD	Plot SubUse: Bungalow/ Dwelling / Non Apartment	
Authority: DHANBAD MUNICIPAL CORPORATION	PlotNearby/ReligiousStructure: NA	
Inward No: DMC/BP/0299/W22/2023	Plot/SubPlot No: 218 (O) / 829(N)	
Application Type: General Proposal	North: Plot No. - SANJAY RAJAK & OTHERS	
Project Type: Building Permission	South: Plot No. - RAM PADO NAPIT	
Nature of Development: New	East: Road Width - 4.57	
Location of Development Area: Old Area	West: Plot No. - SMT PARWATI DEVI	
<b>AREA DETAILS:</b>		
AREA OF PLOT (Minimum)	(A)	SQ.MT.
NET AREA OF PLOT/Gross Plot Area	(A-Deductions)	314.49
Deduction for Balance Plot Area(from Gross Plot Area)		
Common Plot		33.40
Total		33.40
BALANCE AREA OF PLOT(Net Plot Area - Recreational/Amenity space)	(A-Deductions)	281.09
PLOT AREA FOR COVERAGE(Net Plot Area)	(A-Deductions)	314.49
Plot Area for FAR (Net Plot Area + Road Widening Area)	(A-Deductions)	314.49
<b>COVERAGE CHECK</b>		
Permissible Coverage area ( 60.00 % )		188.69
Proposed Coverage Area ( 35.59 % )		111.93
Total Prop. Coverage Area ( 35.59 % )		111.93
Balance coverage area ( 24.41 % )		76.76
<b>FAR CHECK</b>		
Perm. FAR Area ( 1.500 )		471.73
Total Perm. FAR area		471.73
Residential FAR		222.66
Proposed FAR Area		222.66
Total Proposed FAR Area		222.66
Consumed FAR (Factor)		0.71
Balance FAR Area		249.07
<b>BUILT UP AREA CHECK</b>		
Total Proposed BuiltUp Area		226.70
ARCHITECT (Regd)	Priyank Mangalam	
ENGINEER (Regd)		
SUPERVISOR (Regd)		
OWNER (Regd)	SANJU DEVI	
DEVELOPMENT AUTHORITY		LOCAL BODY

COLOR INDEX	
PLOT BOUNDARY	Black
ABUTTING ROAD	Green
PROPOSED CONSTRUCTION	Red
COMMON PLOT	Yellow
ROAD WIDENING AREA	Orange
EXISTING (To be retained)	Blue
EXISTING (To be demolished)	Light Blue

SCHEDULE OF DOOR:

BUILDING NAME	NAME	LENGTH	HEIGHT	NOS
RESI (GS PRASAD)	D	0.75	2.10	06
RESI (GS PRASAD)	D	0.80	2.10	01
RESI (GS PRASAD)	D	0.97	2.10	01
RESI (GS PRASAD)	D	0.98	2.10	05
RESI (GS PRASAD)	D	1.20	2.10	02
RESI (GS PRASAD)	D	2.00	2.10	02

SCHEDULE OF WINDOW/VENTILATION:

BUILDING NAME	NAME	LENGTH	HEIGHT	NOS
RESI (GS PRASAD)	V	0.60	1.50	04
RESI (GS PRASAD)	W	0.90	1.20	01
RESI (GS PRASAD)	W	1.20	1.20	02
RESI (GS PRASAD)	W	1.80	1.20	06
RESI (GS PRASAD)	W	1.80	1.52	02
RESI (GS PRASAD)	W	2.80	1.20	01
RESI (GS PRASAD)	W	4.00	1.20	01

UnitBUA Table for Building :RESI (GS PRASAD)

FLOOR	Name	UnitBUA Type	UnitBUA Area	Carpet Area	No. of Rooms	No. of Tenement
GROUND FLOOR PLAN	SPLIT 1	FLAT	199.30	199.25	8	1
FIRST FLOOR PLAN	SPLIT 1	FLAT	0.00	0.00	8	0
Total:			199.30	199.25	16	1

Building :RESI (GS PRASAD)

Floor Name	Total Built Up Area (Sq.mt.)	Deductions (Area in Sq.mt.)	Proposed FAR Area (Sq.mt.)	Total FAR Area (Sq.mt.)	Total Consumed Additional FAR Area (Sq.mt.)	Tnmt (No.)
Ground Floor	111.93	0.00	111.93	111.93	111.93	01
First Floor	114.77	4.04	110.73	110.73	110.73	00
Terrace Floor	0.00	0.00	0.00	0.00	0.00	00
Total :	226.70	4.04	222.66	222.66	222.66	01
Total Number of Same Buildings	1					
Total :	226.70	4.04	222.66	222.66	222.66	01

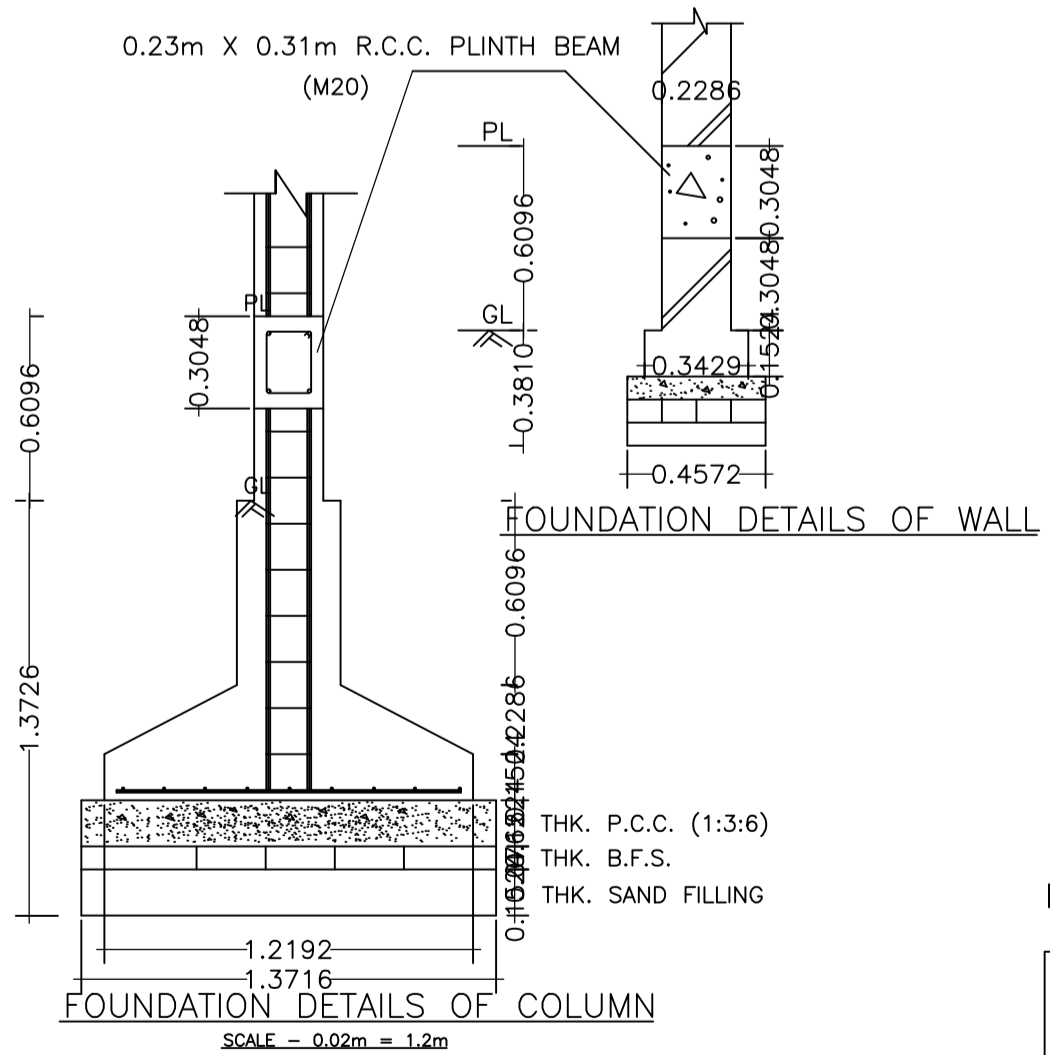
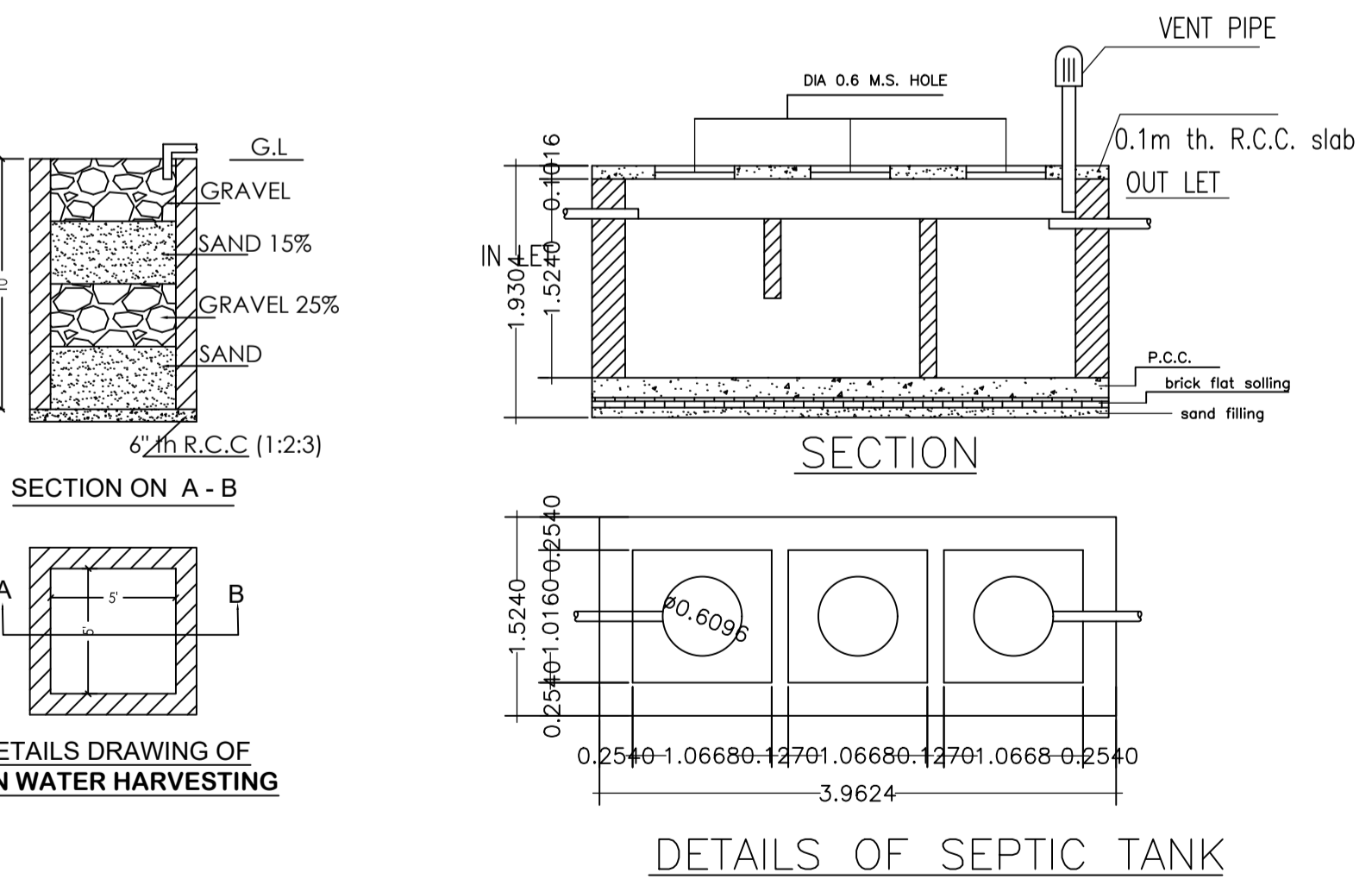
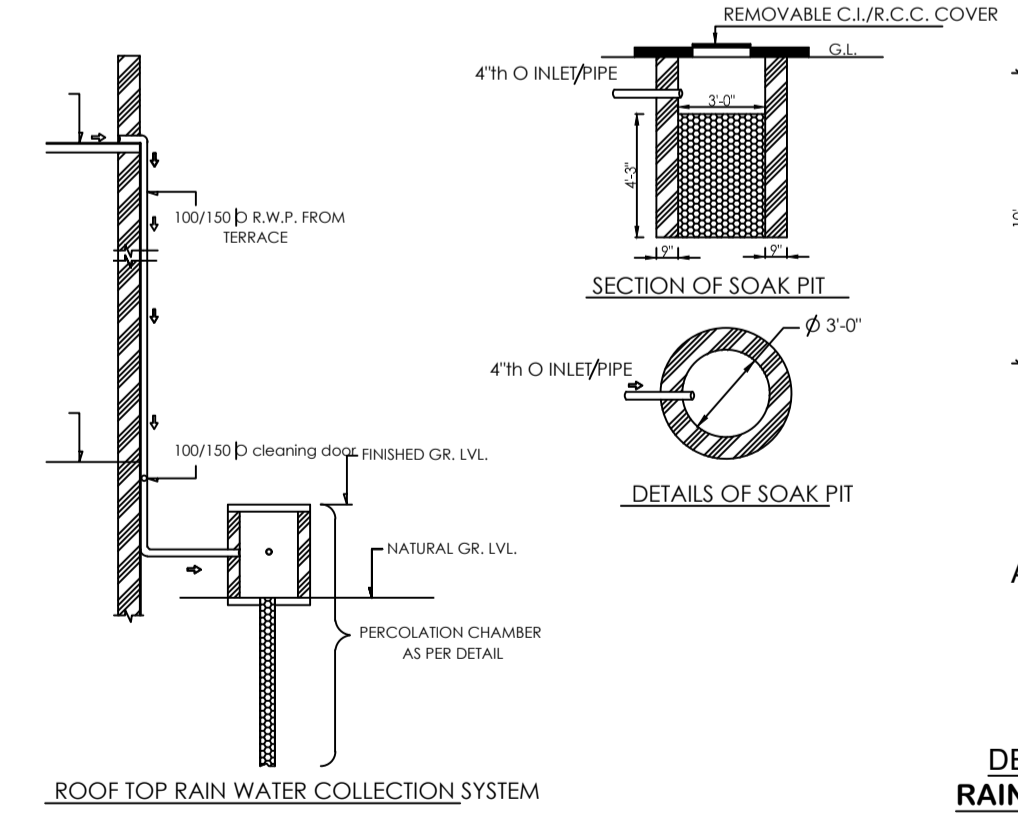

Buildingwise Floor FAR Details

Floor Name	Building Name		Total	
	Proposed Built Up Area (Sq.mt.)	Proposed FAR Area (Sq.mt.)	Total Proposed Built Up Area (Sq.mt.)	Total FAR Area (Sq.mt.)
Ground Floor	111.93	111.93	111.93	111.93
First Floor	114.77	110.73	114.77	110.73
Terrace Floor	0.00	0.00	0.00	0.00
Total :	226.70	222.66	226.70	222.66

Building USE/SUBUSE Details

Building Name	Building Use	Building SubUse	Building Structure
RESI (GS PRASAD)	Residential	Bungalow/ Dwelling / Non Apartment	Non-Highrise

Balcony Calculations Table

FLOOR	SIZE	AREA	TOTAL AREA
FIRST FLOOR PLAN	1.20 X 6.75 X 1 X 1	8.09	8.09
Total			8.09

FAR & Tenement Details (Table 4c-1)

Building	No. of Same Bldg	Total Built Up Area (Sq.mt.)	Deductions (Area in Sq.mt.)	Proposed FAR Area (Sq.mt.)	Total FAR Area (Sq.mt.)	Total Consumed Additional FAR Area (Sq.mt.)	Tnmt (No.)
RESI (GS PRASAD)	1	226.70	4.04	222.66	222.66	222.66	01
Grand Total :	1	226.70	4.04	222.66	222.66	222.66	01

LTP NAME AND SIGNATURE	STRUCTURAL ENG'S NAME AND SIGNATURE	BUILDER NAME AND SIGNATURE	DIGITAL SIGNATURE
Priyank Mangalam DMC/ARC/0008/2018			

DATE	06-10-2023
SHEET NO.	2
Proposal Basic Information	
Proposal File No.	DMC/BP/0299/W22/2023
Owner Name	SANJU DEVI
Khata No	977(N)/136(O)
Plot No	218 (O) / 829(N)
Village Name	Saraidhela
Use	Residential
SubUse	Bungalow/ Dwelling / Non Apartment

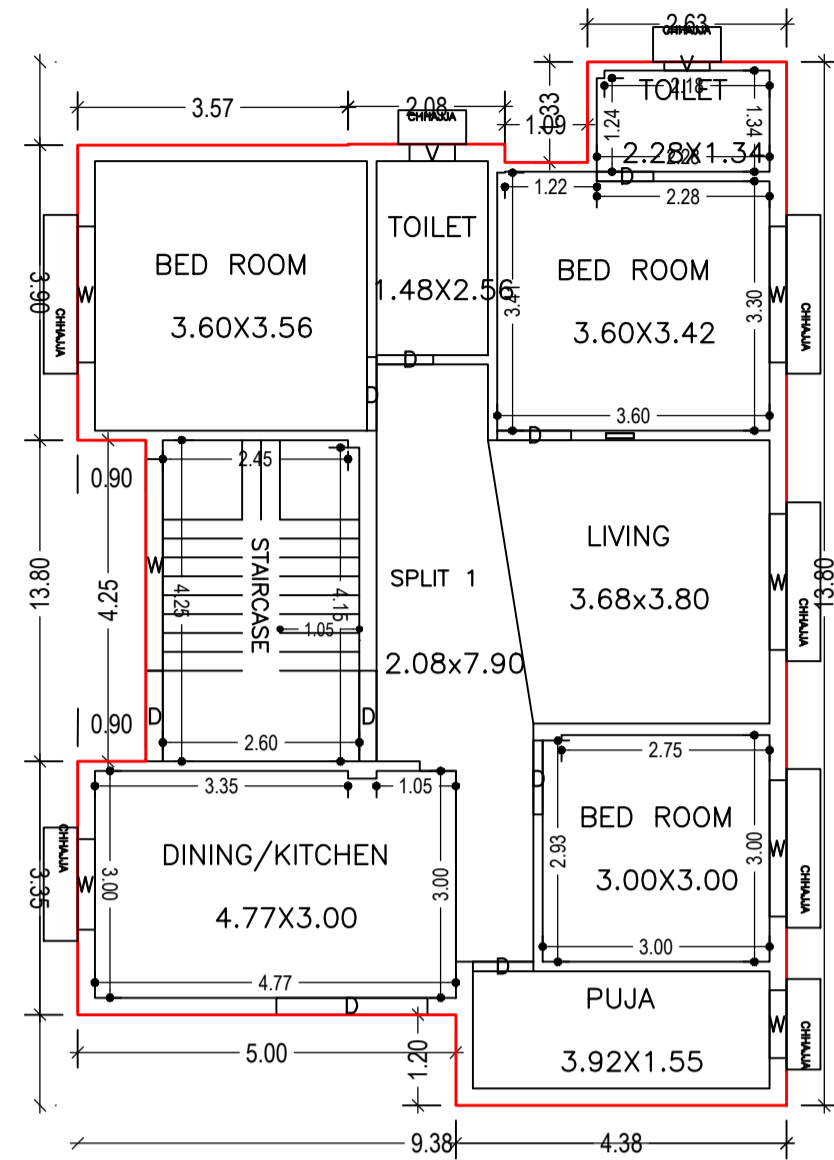

GROUND FLOOR PLAN  
(Proposed)  
(SCALE 1:100)

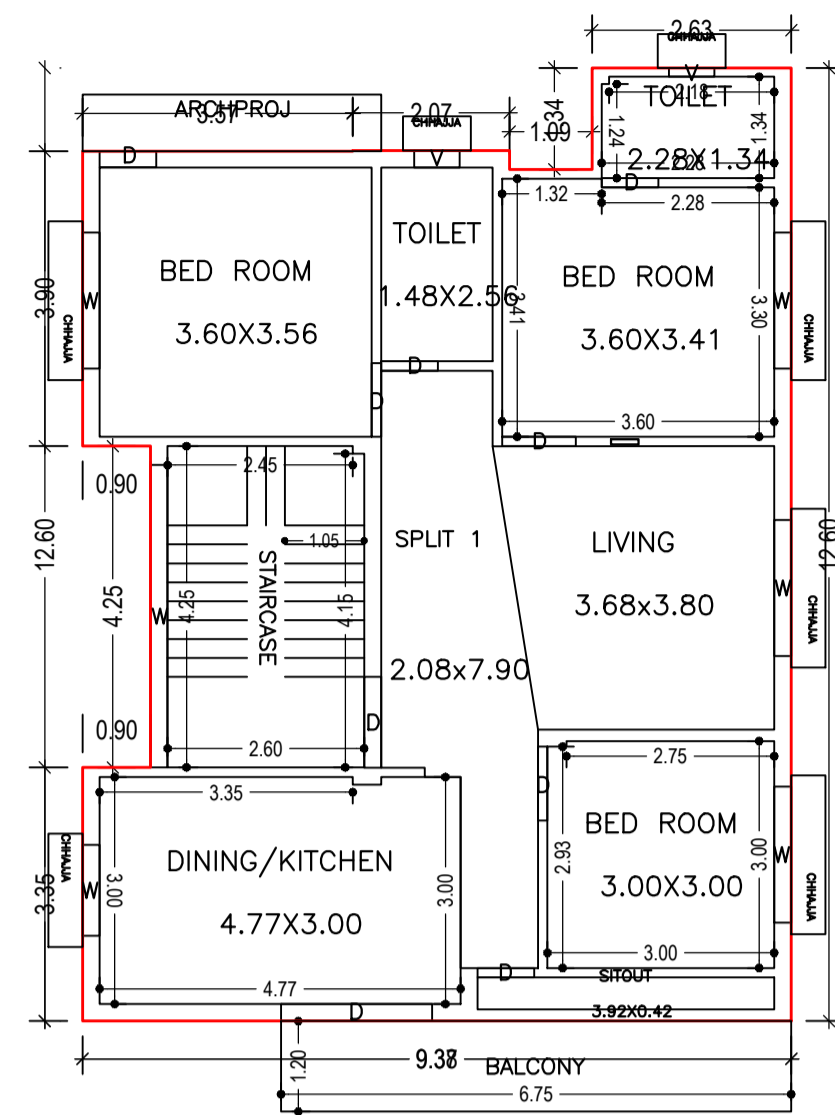

FIRST FLOOR PLAN  
(Proposed)  
(SCALE 1:100)

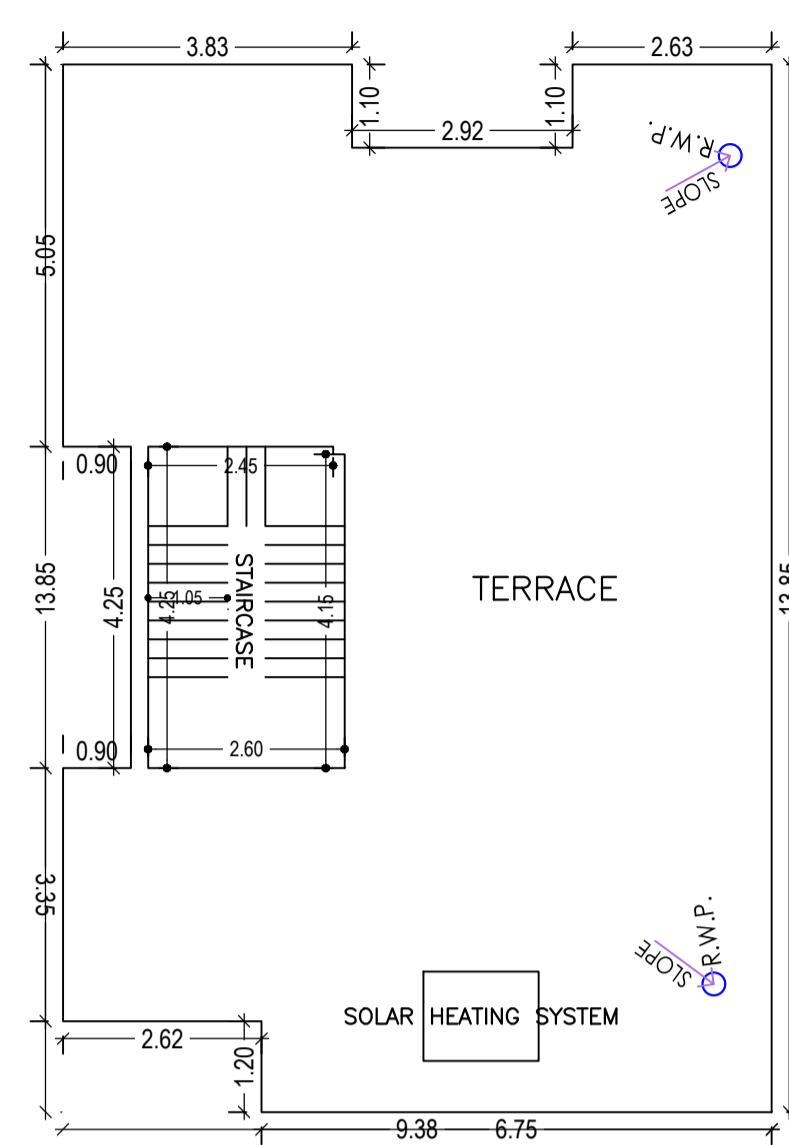

TERRACE FLOOR PLAN  
(SCALE 1:100)

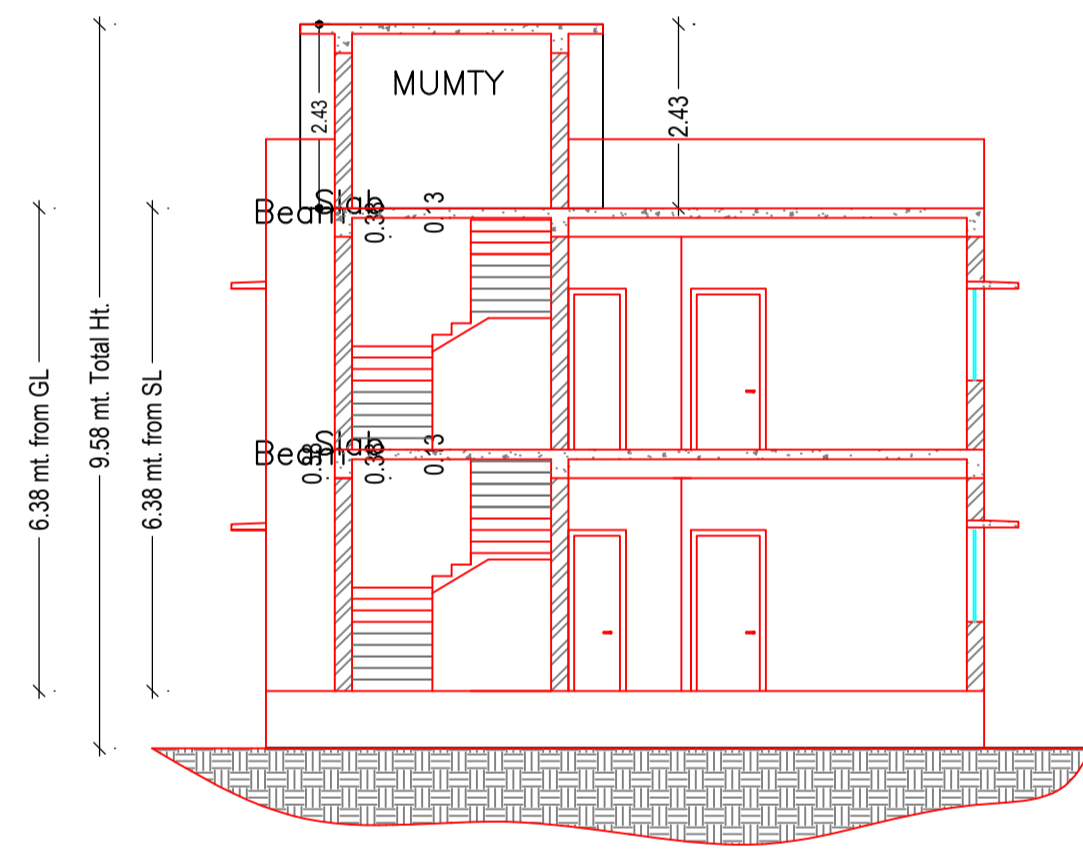
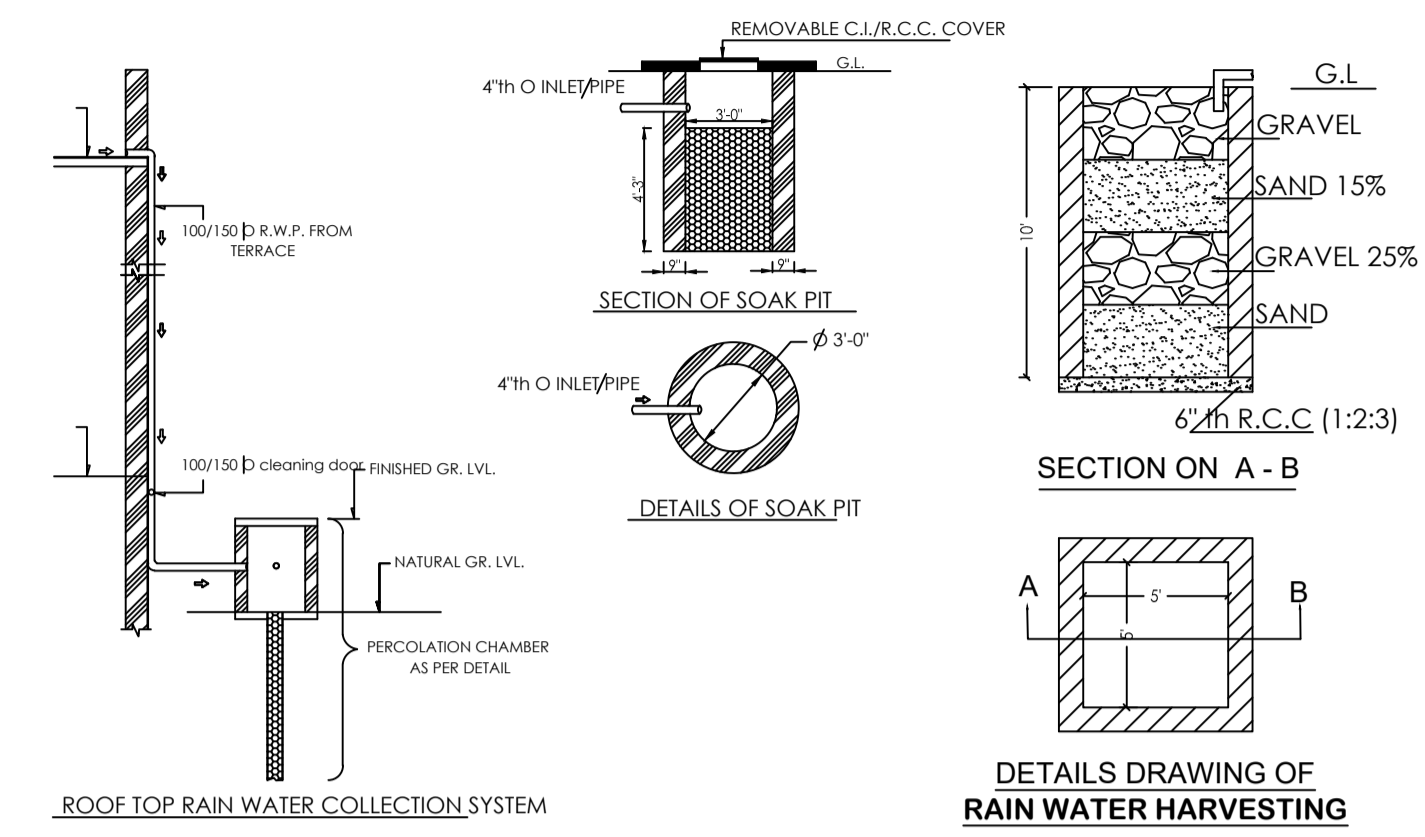

SECTION - XX

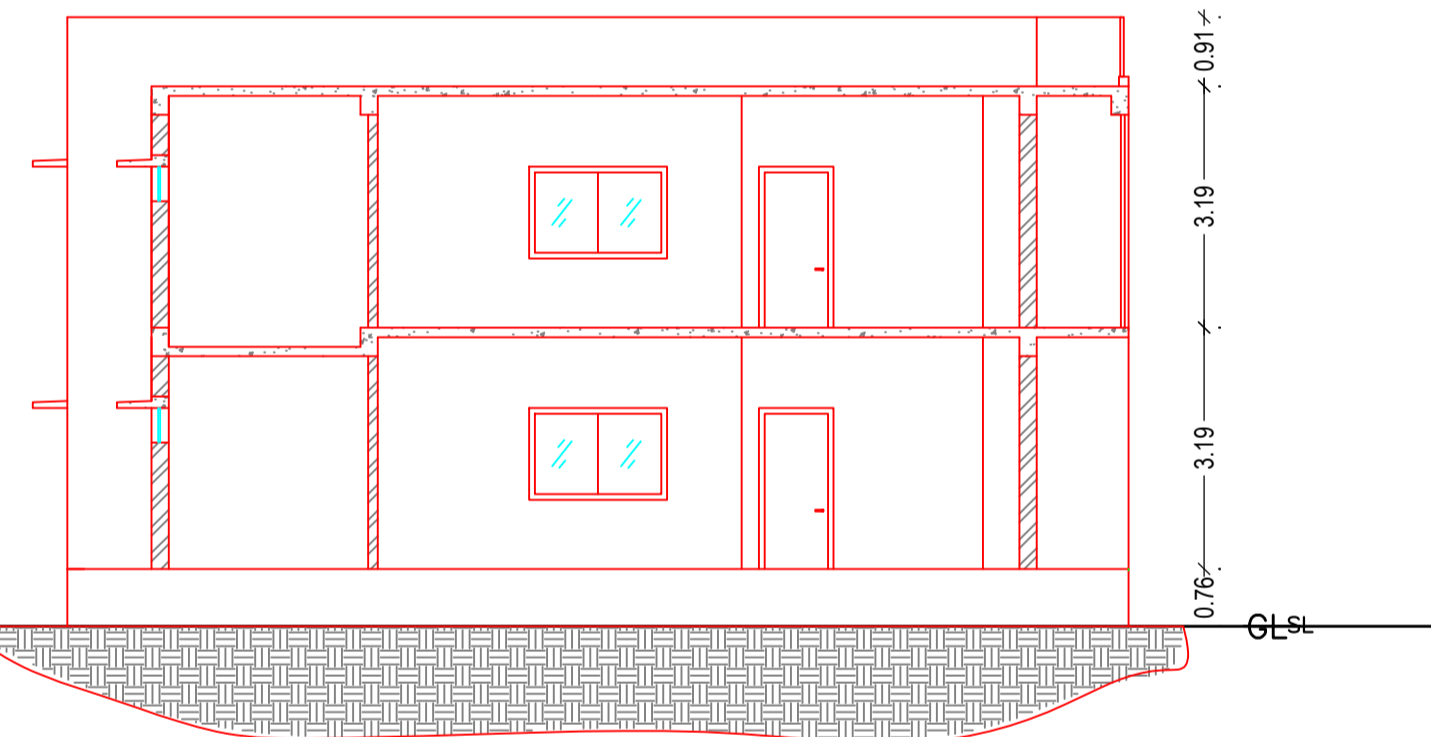

SECTION - YY

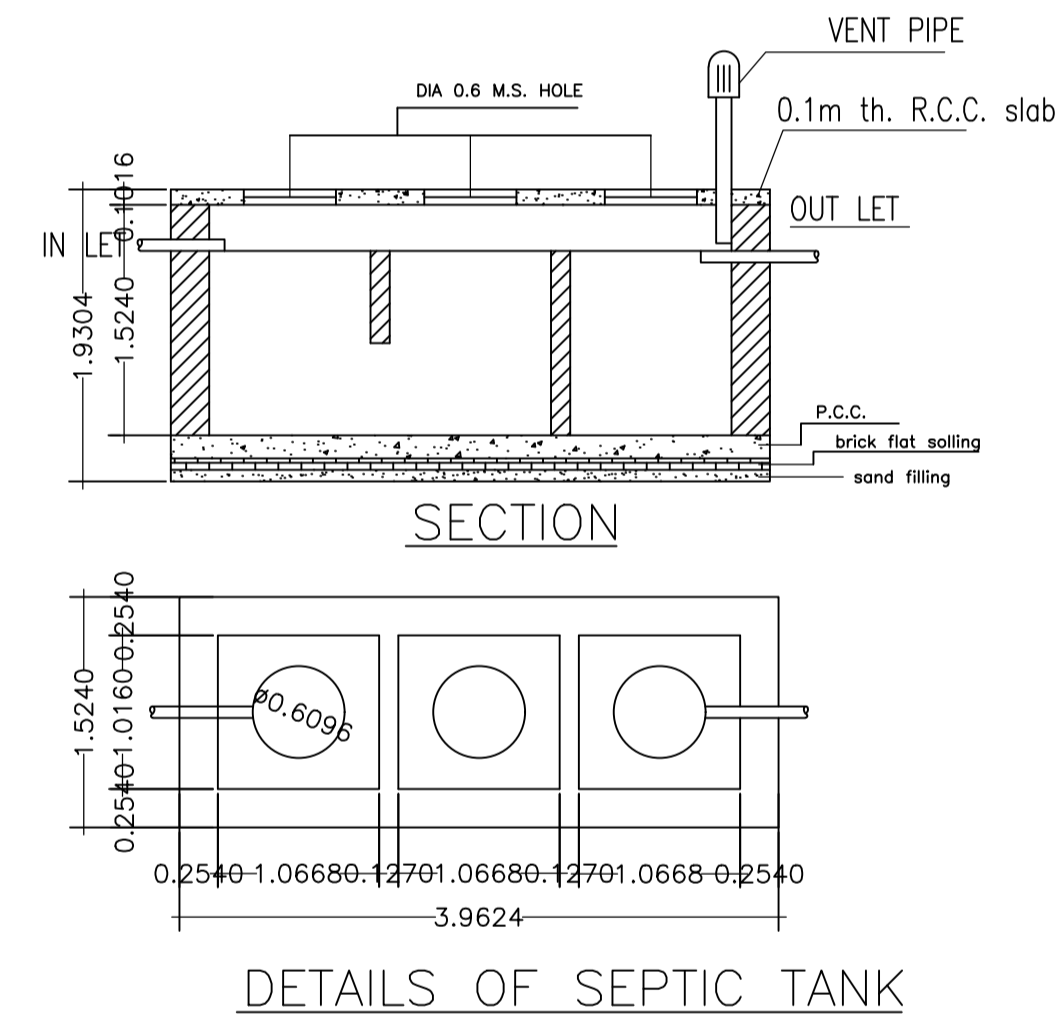

DETAILS OF SEPTIC TANK

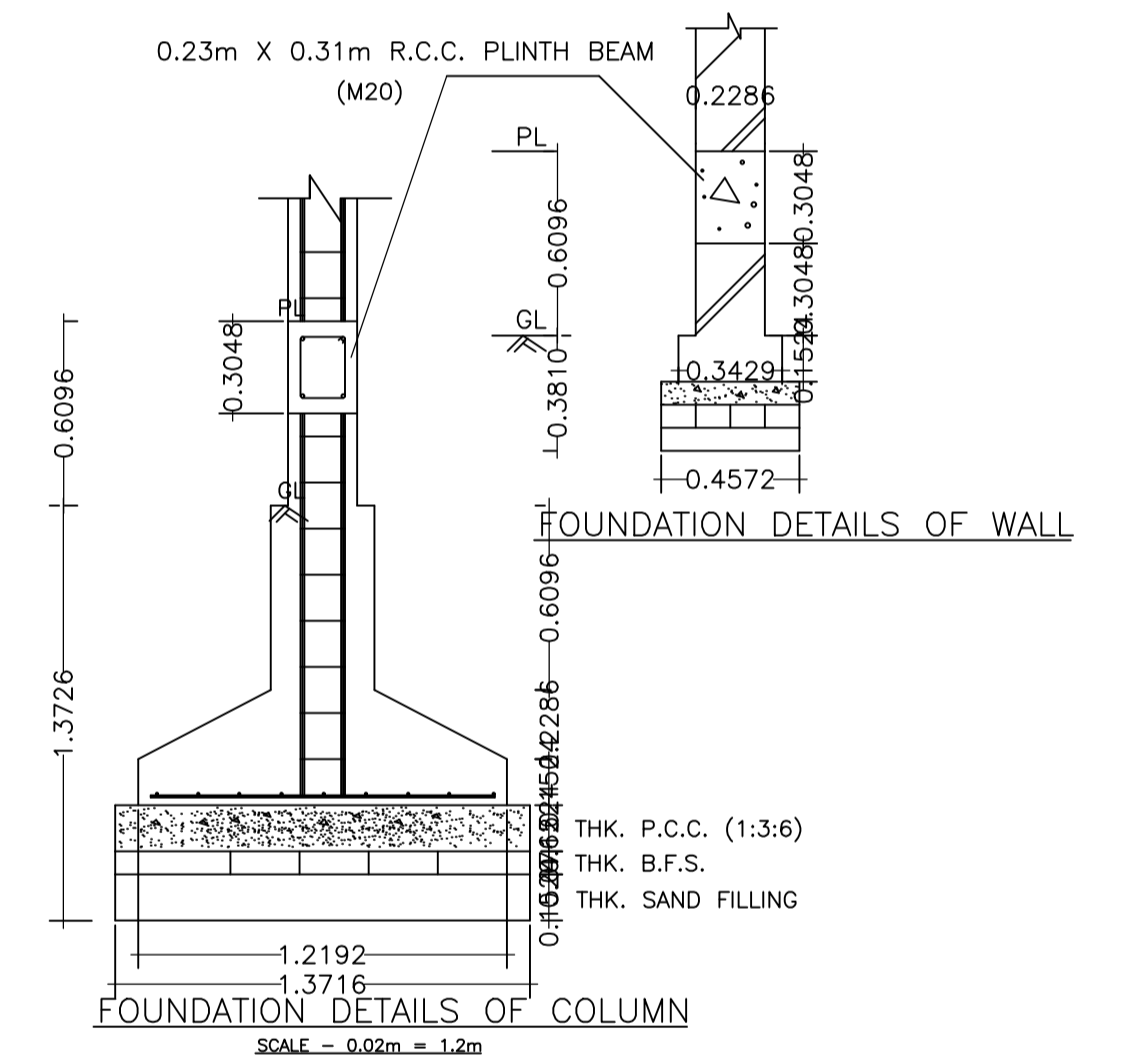

FOUNDATION DETAILS OF COLUMN  
SCALE = 0.02m = 1.2m

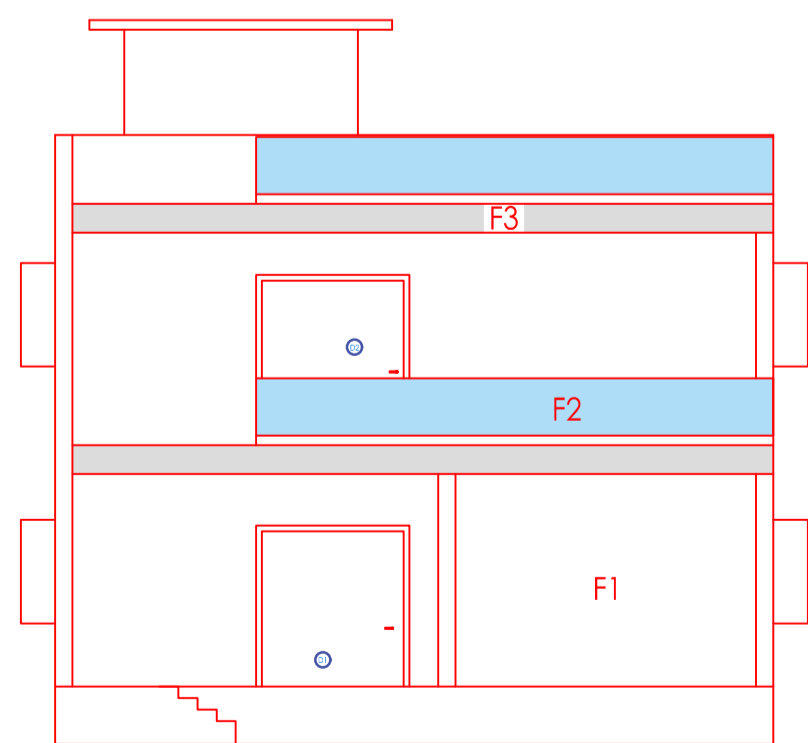

FRONT ELEVATION

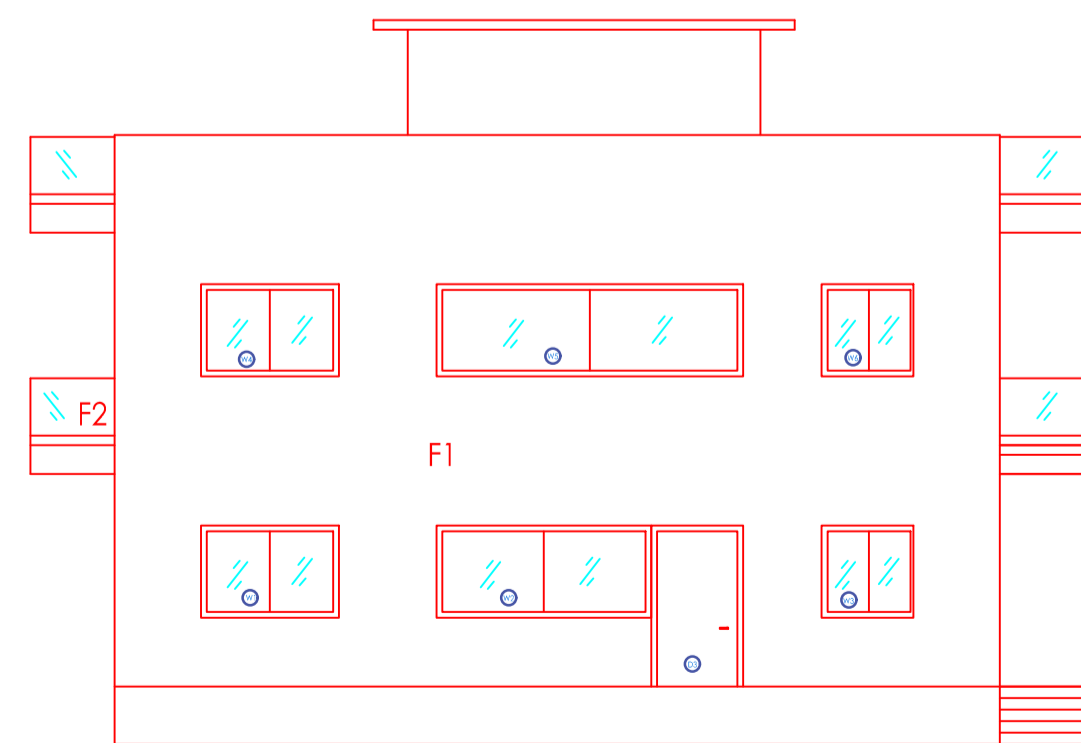

SIDE ELEVATION

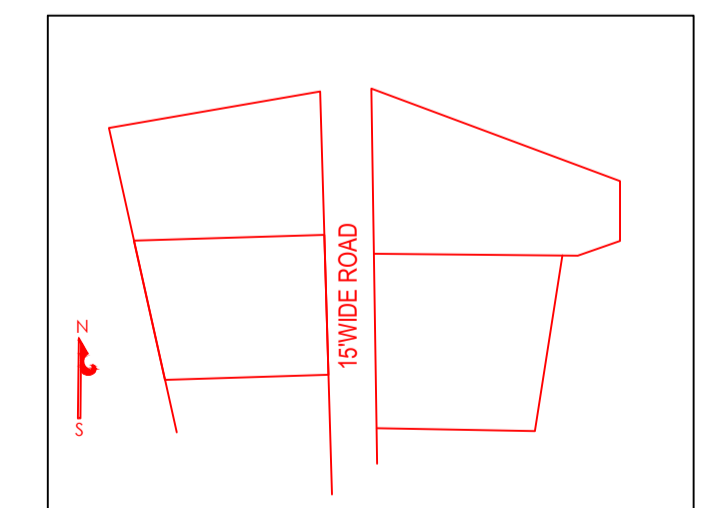
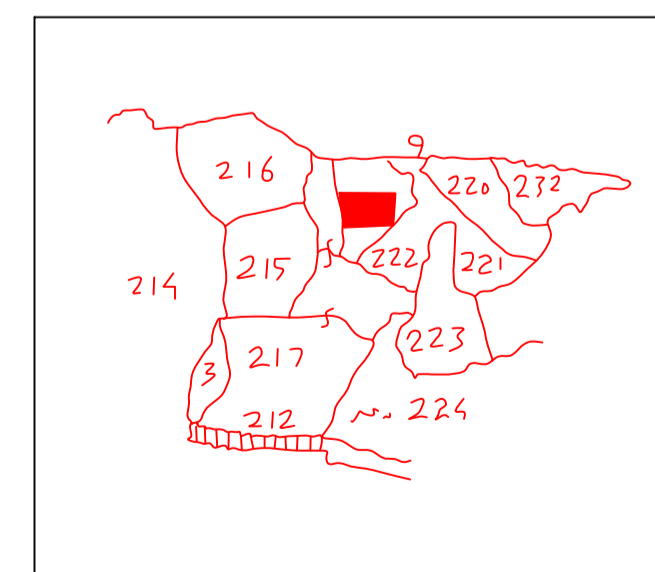

LTP NAME AND SIGNATURE Priyank Mangalam DMC/ARC/0008/2018	STRUCTURAL ENG'S NAME AND SIGNATURE	BUILDER NAME AND SIGNATURE	DIGITAL SIGNATURE
---	-------------------------------------	----------------------------	-------------------