

Proposal Basic Information	
Proposal File No.	DMC/BP/0327/W17/2023
Owner Name	DURGESH NANDINI
Khata No	OLD-30,54,NEW-646,524
Plot No	OLD- 471,467, NEW-511,513
Village Name	Panderpala
Use	Residential
SubUse	Bungalow/ Dwelling / Non Apartment

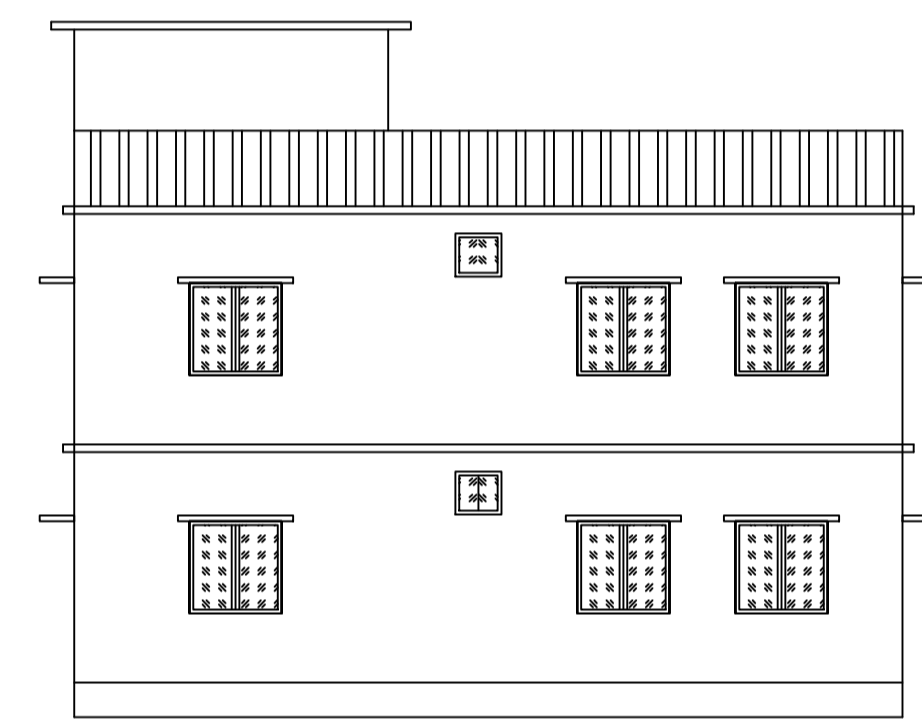
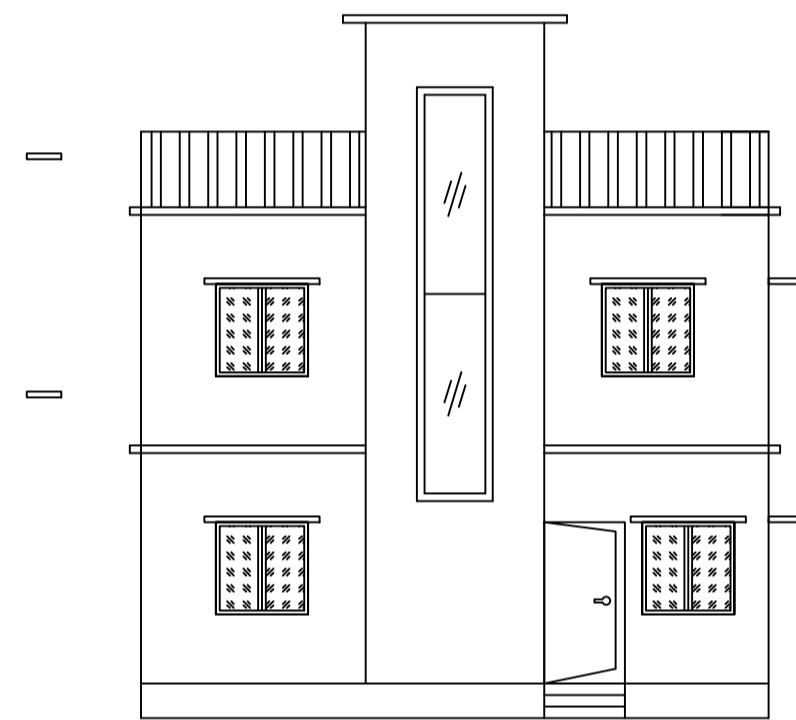
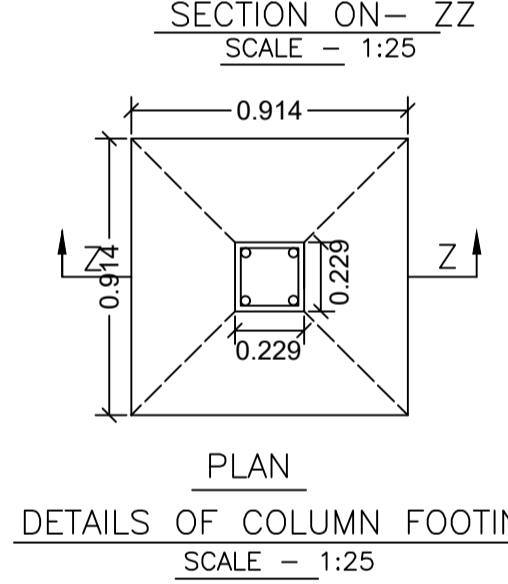
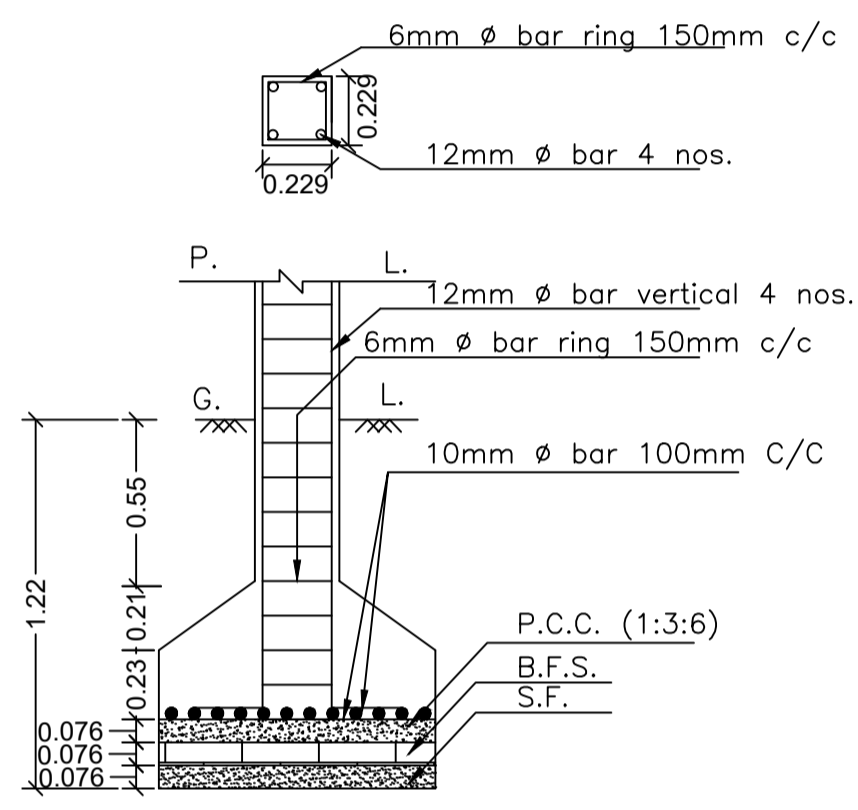
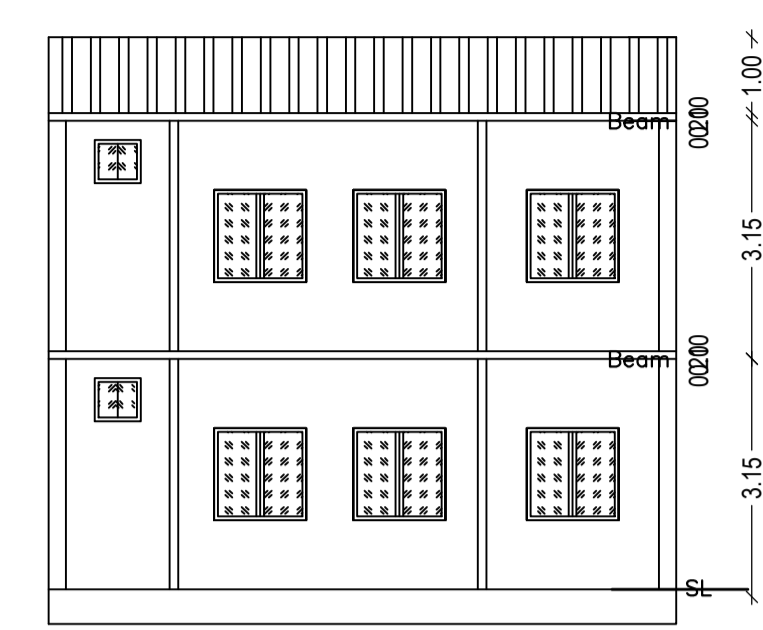
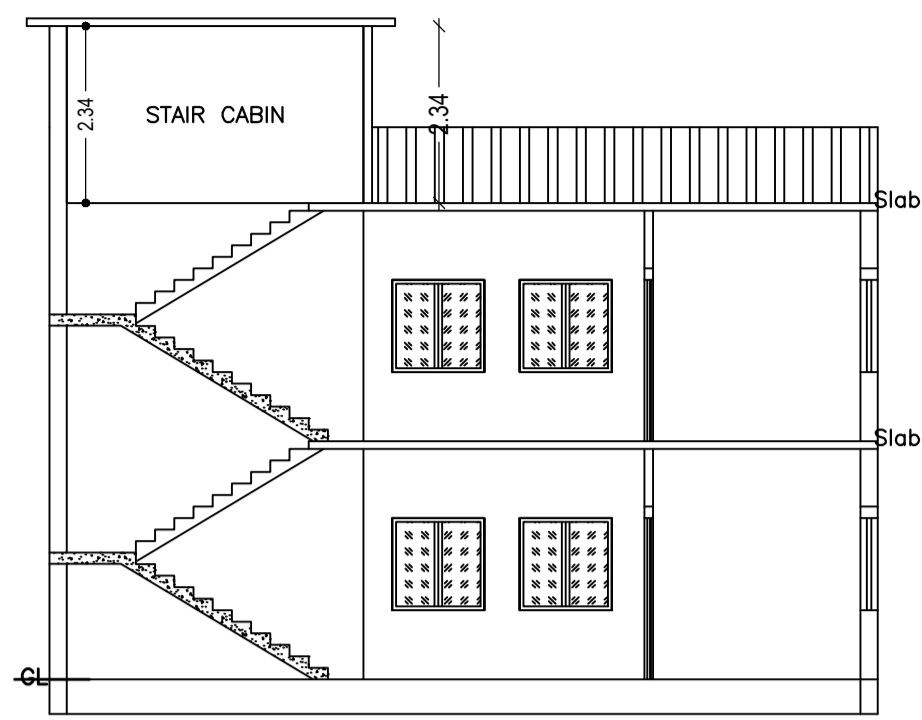
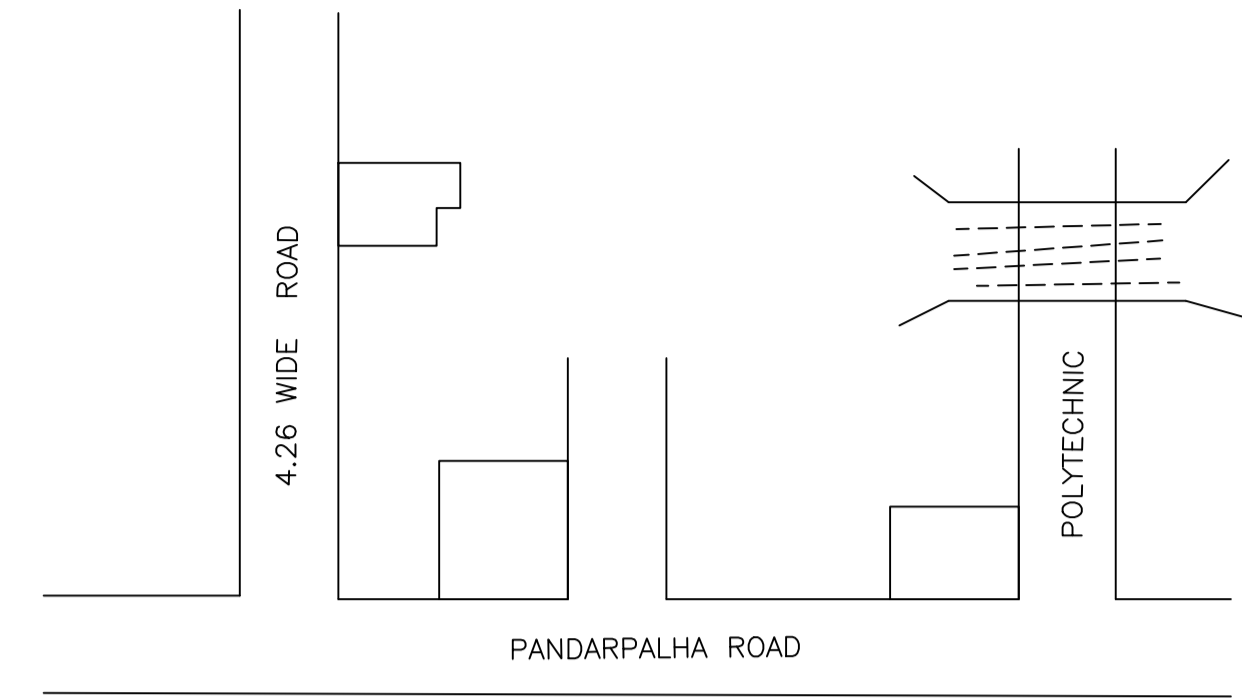
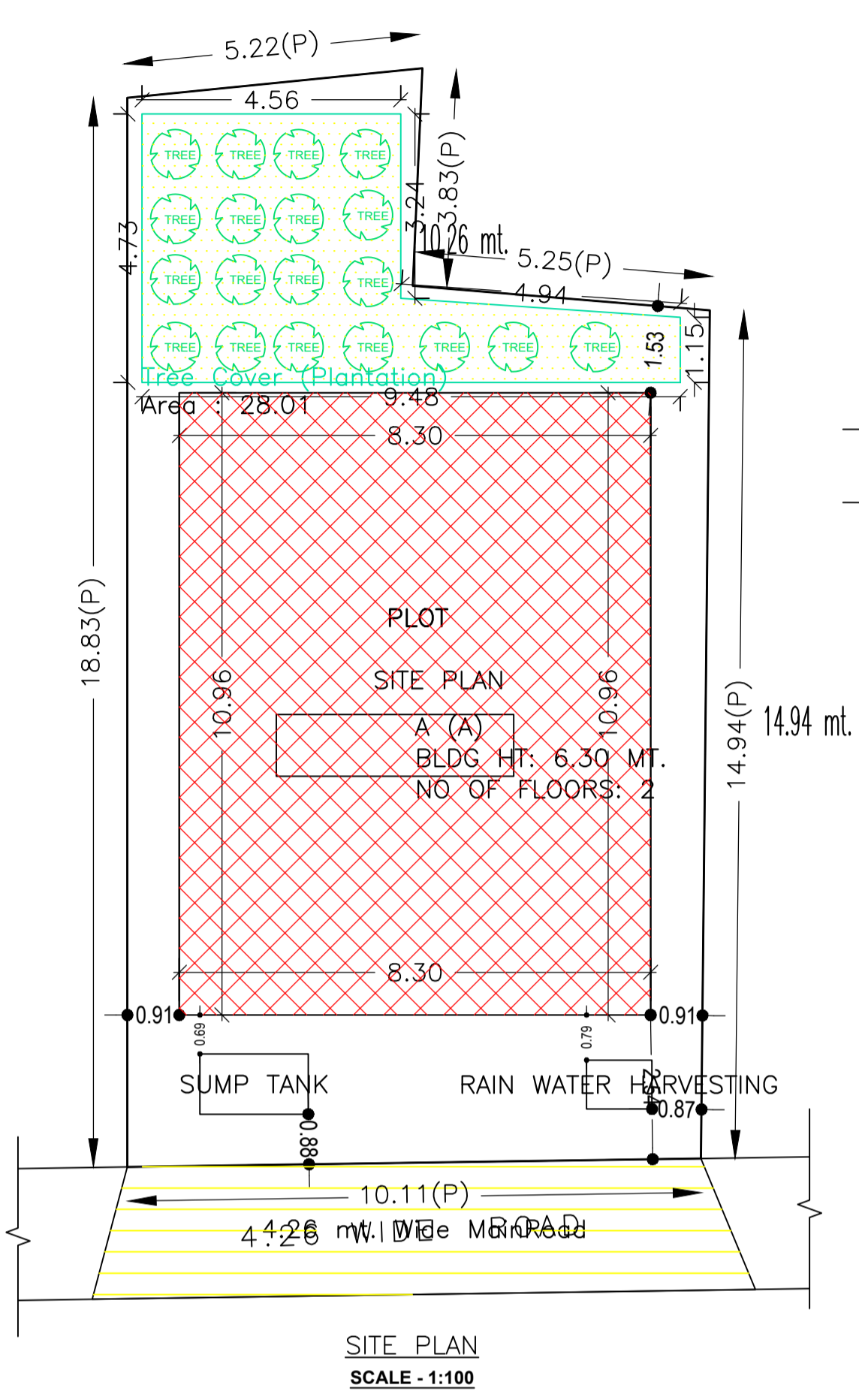

AREA STATEMENT		VERSION NO.: 1.0.66
DHANBAD MUNICIPAL CORPORATION		VERSION DATE: 16/10/2020
PROJECT DETAIL:		
Region: JHARKHAND URBAN LOCAL BODIES	Plot Use: Residential	
District: DHANBAD	Plot SubUse: Bungalow/ Dwelling / Non Apartment	
Authority: DHANBAD MUNICIPAL CORPORATION	PlotNearby/ReligiousStructure: NA	
Inward No: DMC/BP/0327/W17/2023	Plot/SubPlot No: OLD- 471,467, NEW-511,513	
Application Type: General Proposal	North: Plot No. - VENDOR'S N/Z	
Project Type: Building Permission	South: Plot No. - MILAN DUBEY	
Nature of Development: New	East: Plot No. - VENDOR'S N/Z & PLOT NO.-465	
Location of Development Area: Old Area	West: Road Width - 4.26	
AREA DETAILS:		SQ.MT.
AREA OF PLOT (Minimum)	(A)	174.38
NET AREA OF PLOT(Gross Plot Area - Deduction from Gross Plot area)	(A-Deductions)	174.38
Deduction for Balance Plot Area(from Gross Plot Area)		
Common Plot		28.01
Total		28.01
BALANCE AREA OF PLOT(Net Plot Area - Recreational/Amenity space)	(A-Deductions)	146.37
PLOT AREA FOR COVERAGE(Net Plot Area)	(A-Deductions)	174.38
Plot Area for FAR (Net Plot Area + Road Widening Area)	(A-Deductions)	174.38
COVERAGE CHECK		
Permissible Coverage area (70.00 %)		122.07
Proposed Coverage Area (52.17 %)		90.97
Total Prop. Coverage Area (52.17 %)		90.97
Balance coverage area (17.83 %)		31.10
FAR CHECK		
Perm. FAR Area (1.500)		261.57
Total Perm. FAR area		261.57
Residential FAR		181.94
Proposed FAR Area		181.94
Total Proposed FAR Area		181.94
Consumed FAR (Factor)		1.04
Balance FAR Area		79.63
BUILT UP AREA CHECK		
Total Proposed BuiltUp Area		181.94
ARCHITECT (Regd)	SANJEEV KUMAR RAY	
ENGINEER (Regd)		
SUPERVISOR (Regd)		
OWNER (Regd)	DURGESH NANDINI	
DEVELOPMENT AUTHORITY		LOCAL BODY

COLOR INDEX	
PLOT BOUNDARY	Black
ABUTTING ROAD	Green
PROPOSED CONSTRUCTION	Red
COMMON PLOT	Yellow
ROAD WIDENING AREA	Blue
EXISTING (To be retained)	Orange
EXISTING (To be demolished)	Light Blue

Buildingwise Floor FAR Details				
Floor Name	Building Name A (A)		Total	
	Proposed Built Up Area (Sq.mt.)	Proposed FAR Area (Sq.mt.)	Total Proposed Built Up Area (Sq.mt.)	Total FAR Area (Sq.mt.)
Ground Floor	90.97	90.97	90.97	90.97
First Floor	90.97	90.97	90.97	90.97
Terrace Floor	0.00	0.00	0.00	0.00
Total :	181.94	181.94	181.94	181.94

Building USE/SUBUSE Details			
Building Name	Building Use	Building SubUse	Building Structure
A (A)	Residential	Bungalow/ Dwelling / Non Apartment	Non-Highrise

UnitBUA Table for Building :A (A)						
FLOOR	Name	UnitBUA Type	UnitBUA Area (Sq.mt.)	Carpet Area (Sq.mt.)	No. of Rooms	No. of Tenement
GROUND FLOOR PLAN	SPLIT A	FLAT	181.94	181.86	8	1
FIRST FLOOR PLAN	SPLIT A	FLAT	0.00	0.00	8	0
Total:	-	-	181.94	181.86	16	1

FAR & Tenement Details (Table 4c-1)						
Building	No. of Same Bldg	Total Built Up Area (Sq.mt.)	Proposed FAR Area (Sq.mt.) Res.	Total FAR Area (Sq.mt.)	Total Consumed Additional FAR Area (Sq.mt.)	Tnmt (No.)
A (A)	1	181.94	181.94	181.94	181.94	01
Grand Total :	1	181.94	181.94	181.94	181.94	01

SCHEDULE OF DOOR:				
BUILDING NAME	NAME	LENGTH	HEIGHT	NOS
A (A)	D	0.75	2.10	04
A (A)	D	0.91	2.10	02
A (A)	D	1.07	2.10	07

SCHEDULE OF WINDOW/VENTILATION:				
BUILDING NAME	NAME	LENGTH	HEIGHT	NOS
A (A)	V	0.61	1.20	04
A (A)	W	1.22	1.20	20
A (A)	W	1.30	1.20	02

Building :A (A)					
Floor Name	Total Built Up Area (Sq.mt.)	Proposed FAR Area (Sq.mt.) Res.	Total FAR Area (Sq.mt.)	Total Consumed Additional FAR Area (Sq.mt.)	Tnmt (No.)
Ground Floor	90.97	90.97	90.97	90.97	01
First Floor	90.97	90.97	90.97	90.97	00
Terrace Floor	0.00	0.00	0.00	0.00	00
Total :	181.94	181.94	181.94	181.94	01
Total Number of Same Buildings :	1				
Total :	181.94	181.94	181.94	181.94	01

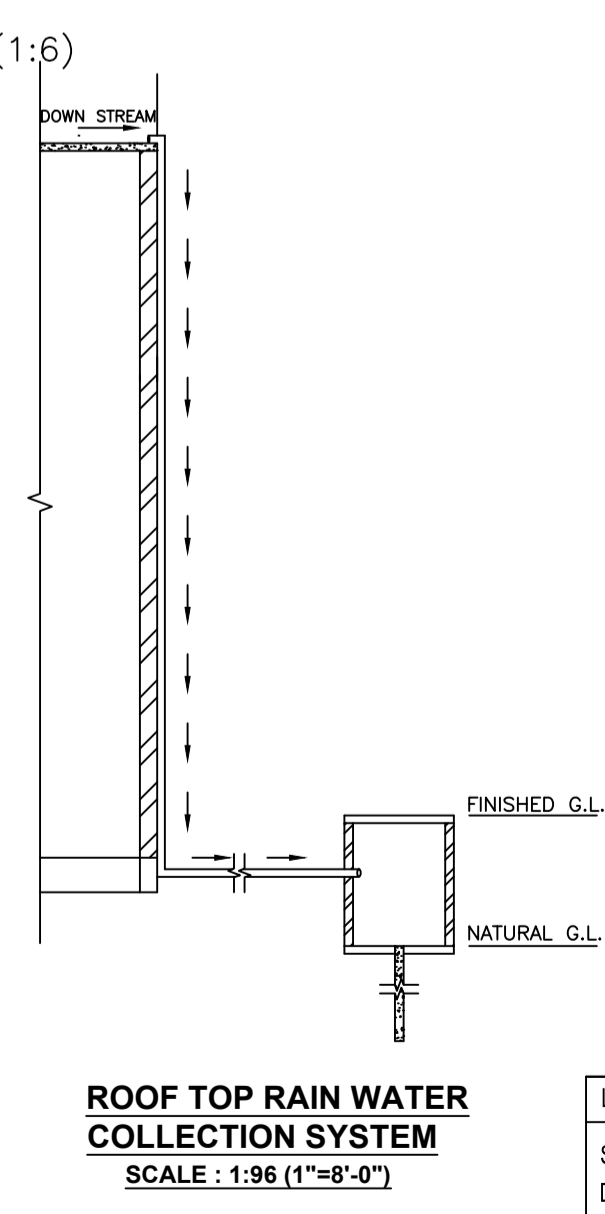
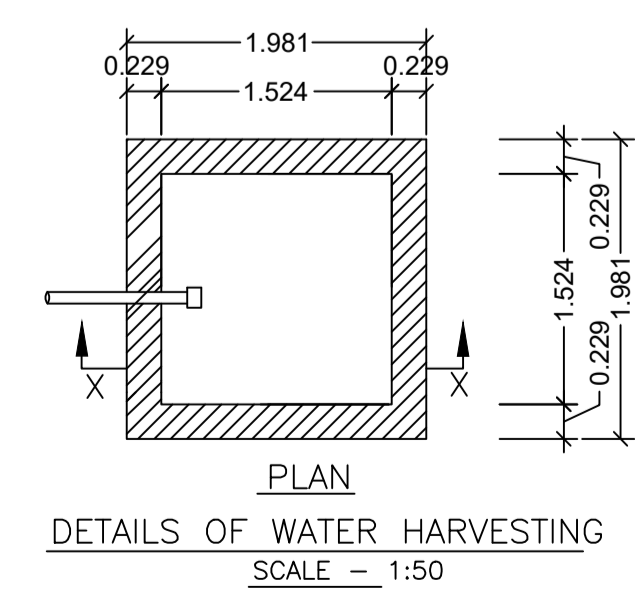
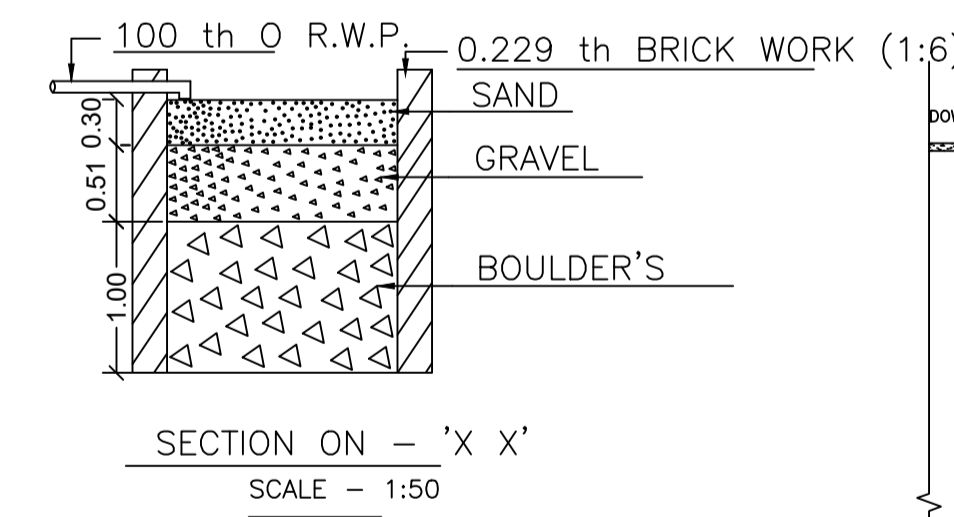
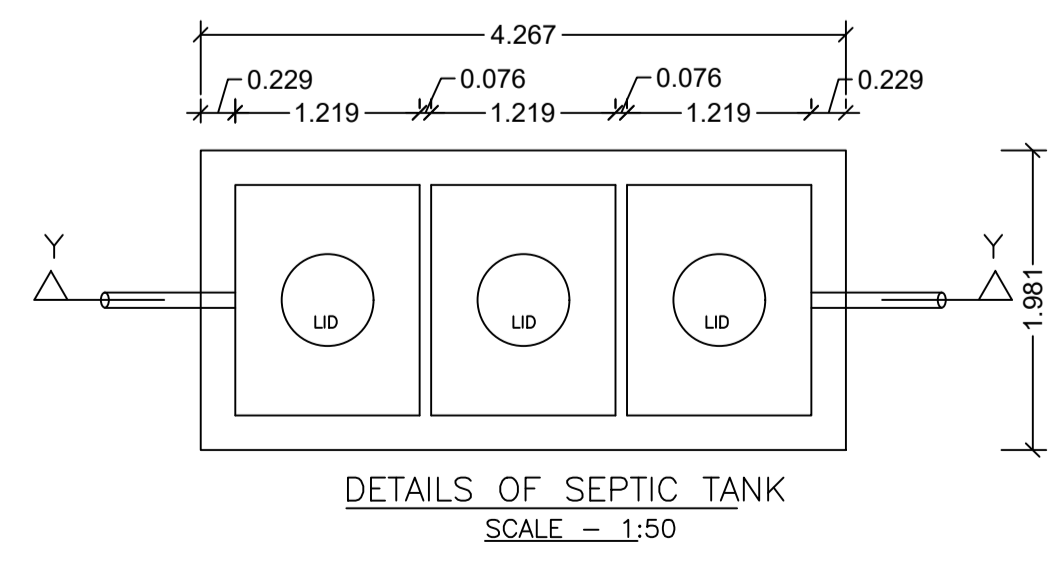
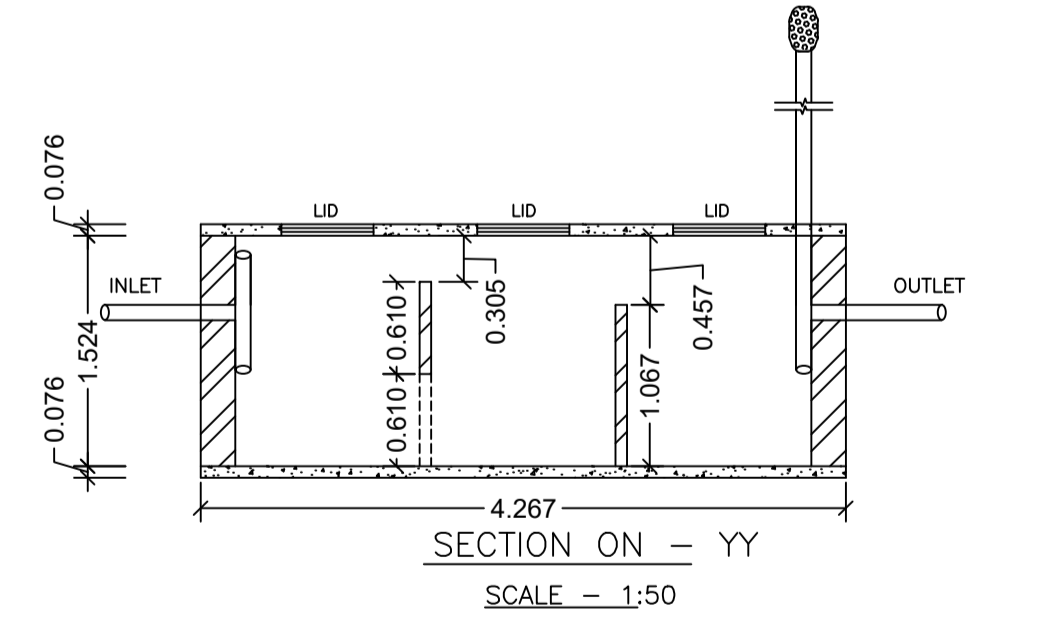

LTP NAME AND SIGNATURE	STRUCTURAL ENG'S NAME AND SIGNATURE	BUILDER NAME AND SIGNATURE	DIGITAL SIGNATURE
SANJEEV KUMAR RAY DMC/ENG/0001/2019			

		DATE	25-11-2023
Proposal Basic Information		SHEET NO.	2
Proposal File No.	DMC/BP/0327/W17/2023		
Owner Name	DURGESH NANDINI		
Khata No	OLD-30,54,NEW-646,524		
Plot No	OLD- 471,467, NEW-511,513		
Village Name	Panderpala		
Use	Residential		
SubUse	Bungalow/ Dwelling / Non Apartment		

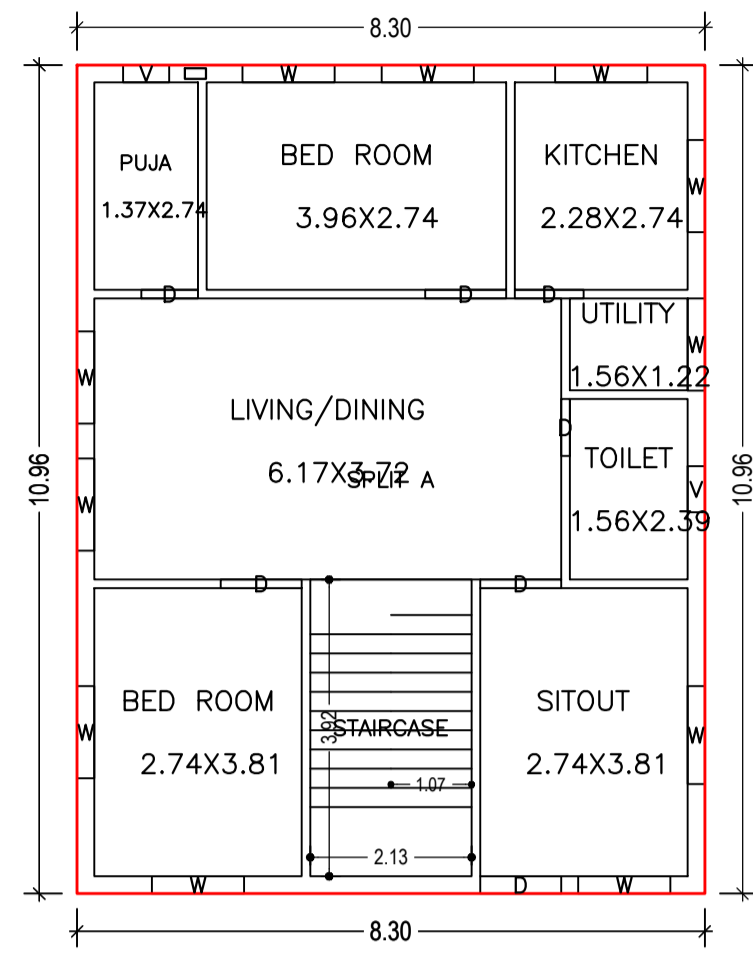

GROUND FLOOR PLAN
(Proposed)
(SCALE 1:100)

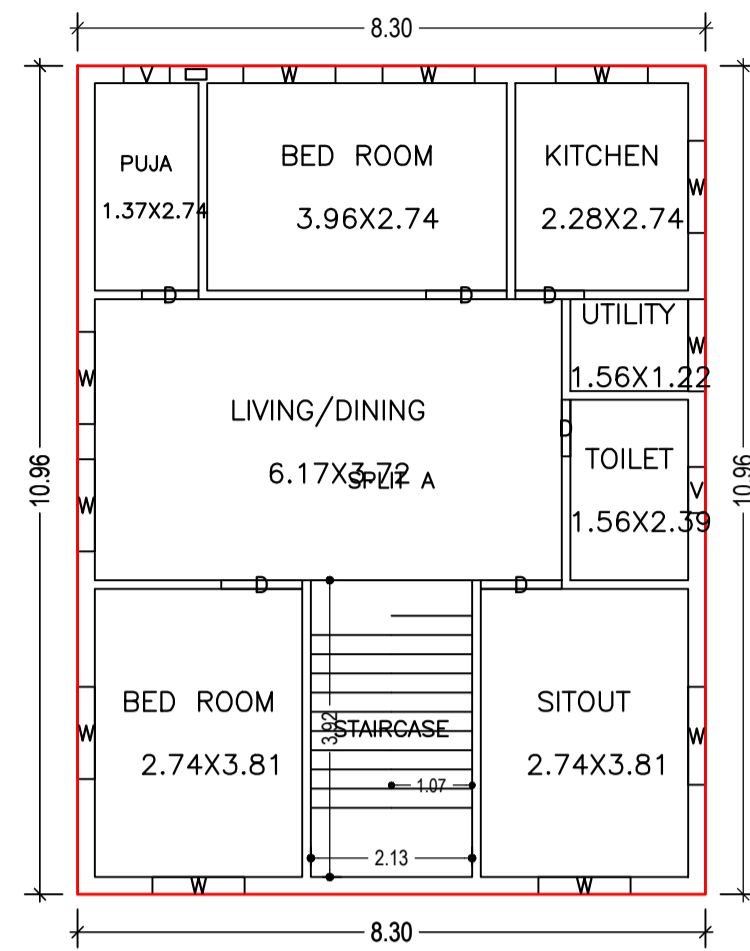

FIRST FLOOR PLAN
(Proposed)
(SCALE 1:100)

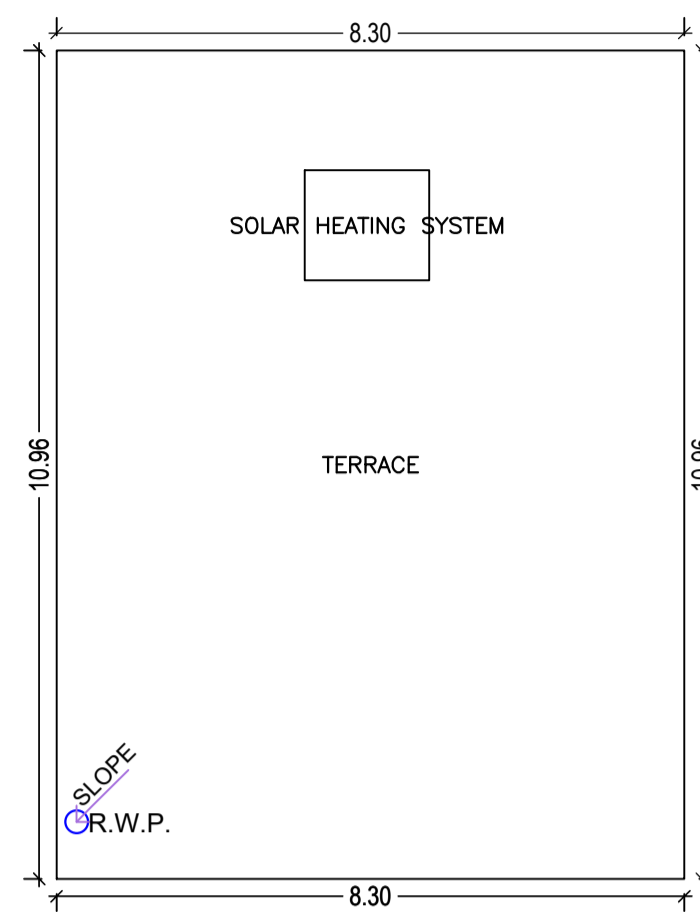

TERRACE FLOOR PLAN
(SCALE 1:100)

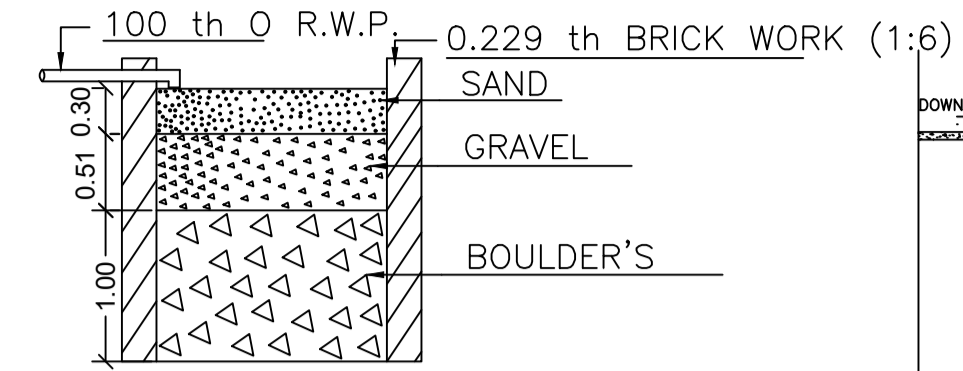

SECTION ON - 'X X'
SCALE - 1:50

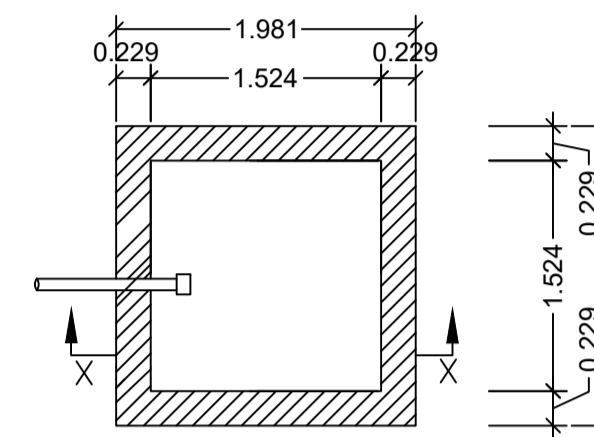

PLAN
DETAILS OF WATER HARVESTING
SCALE - 1:50

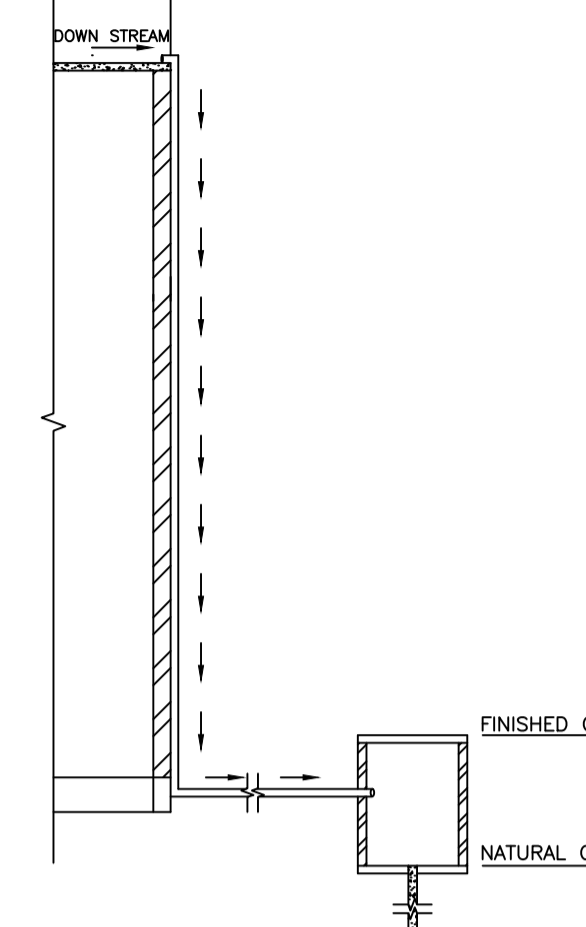

ROOF TOP RAIN WATER
COLLECTION SYSTEM
SCALE : 1:96 (1"=8'-0")

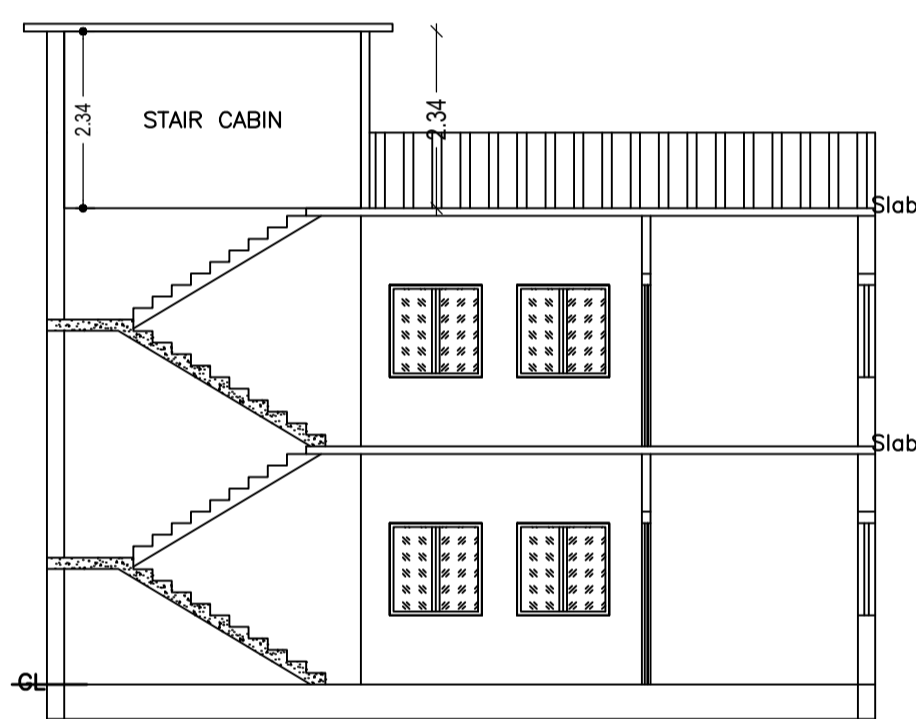

SECTION ON: 'A-A'
SCALE - 1:100

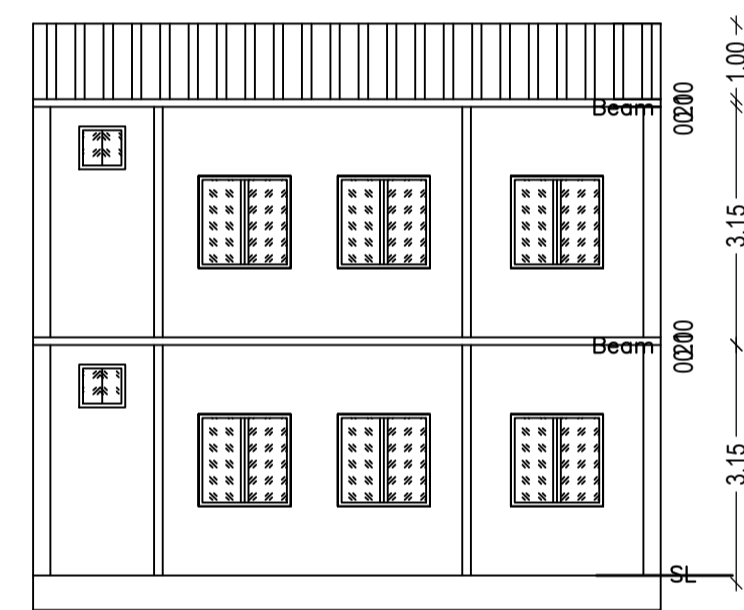

SECTION ON: 'B-B'
SCALE - 1:100

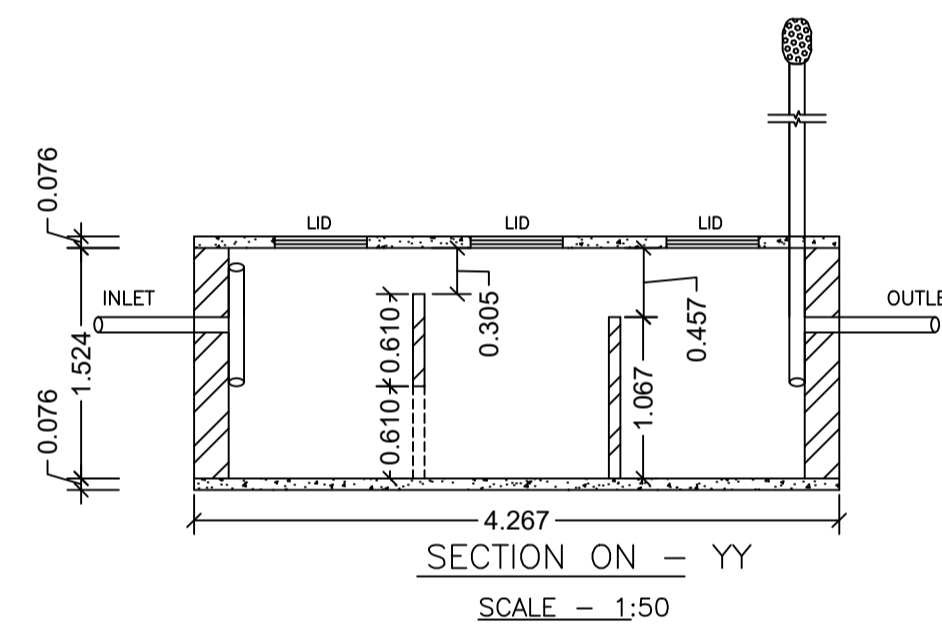

SECTION ON - YY
SCALE - 1:50

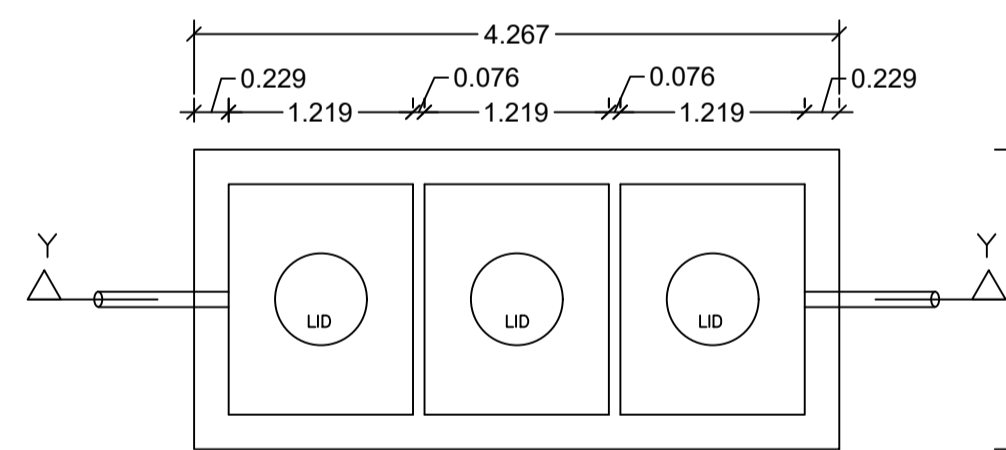

DETAILS OF SEPTIC TANK
SCALE - 1:50

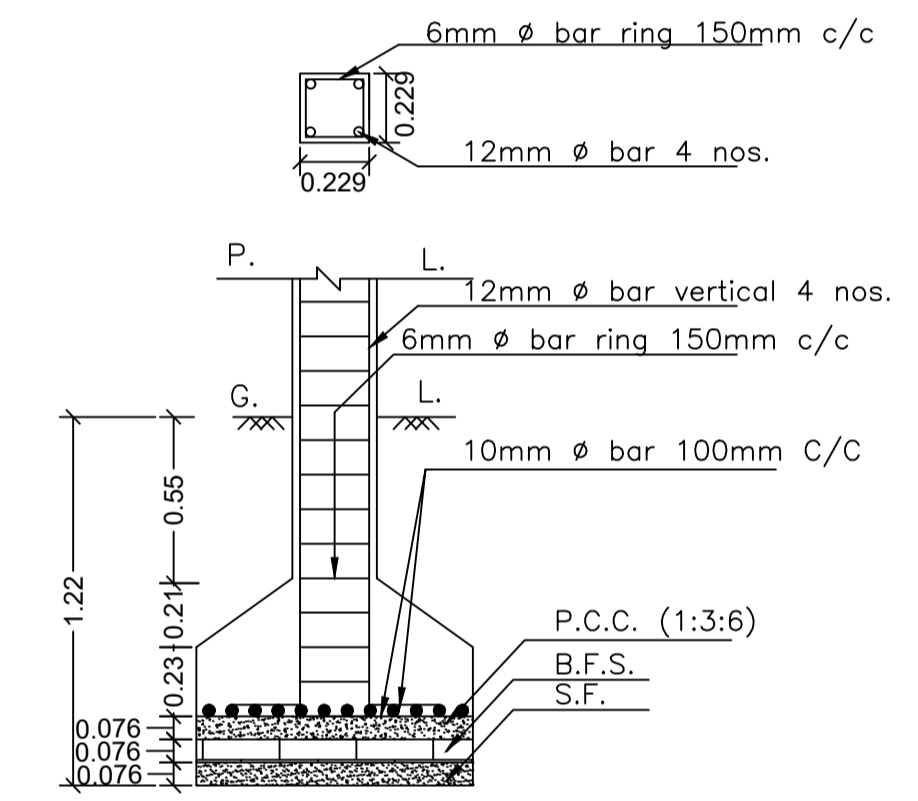

SECTION ON - ZZ
SCALE - 1:25

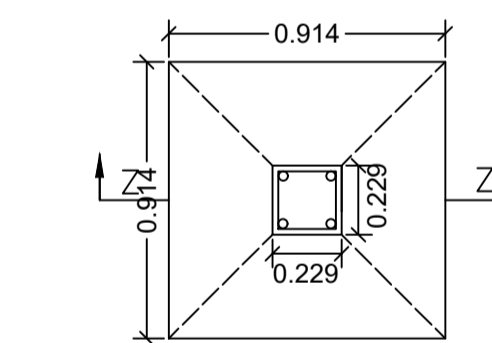

PLAN
DETAILS OF COLUMN FOOTING
SCALE - 1:25

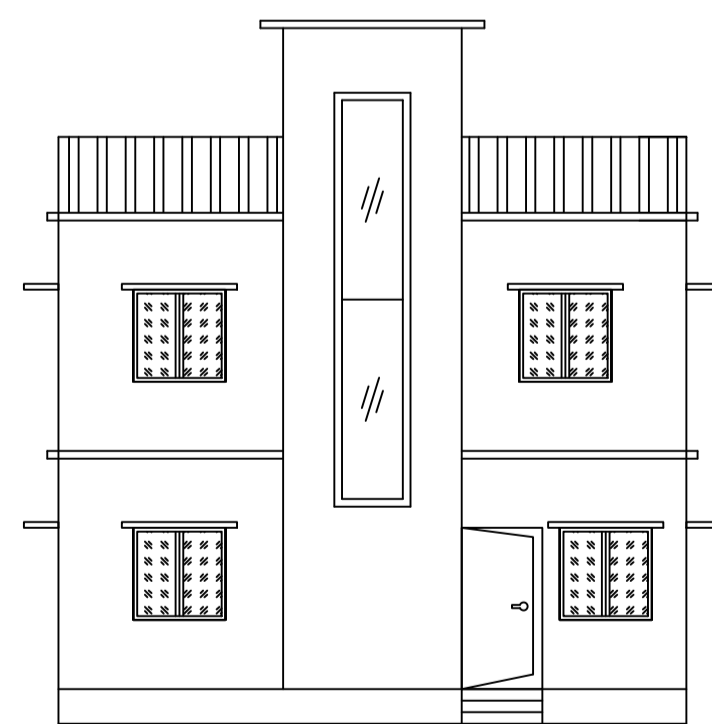

FRONT ELEVATION
SCALE - 1:100

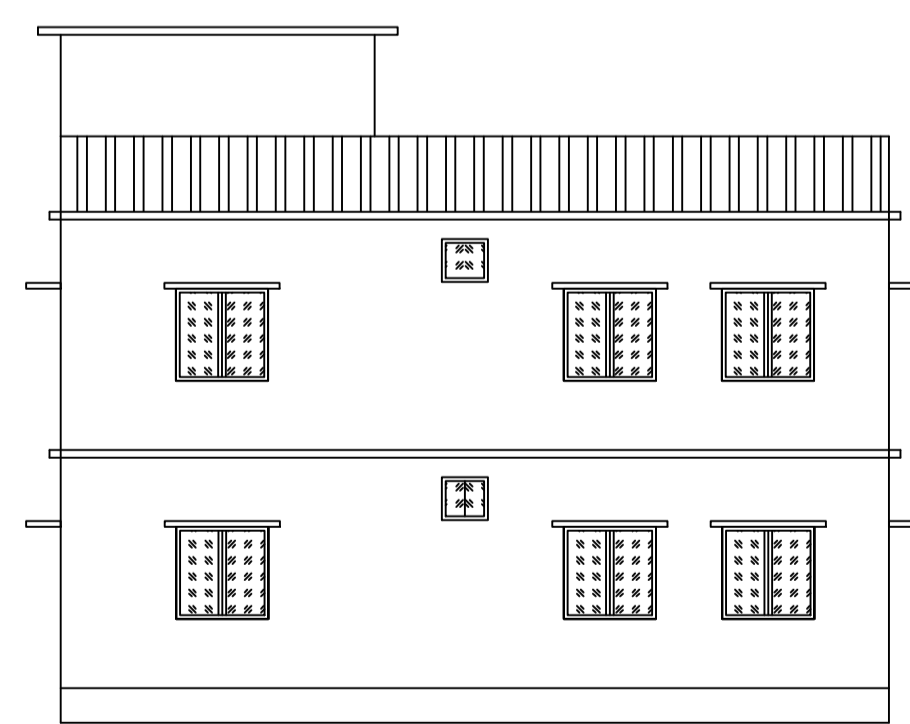

RIGHT SIDE ELEVATION
SCALE - 1:100

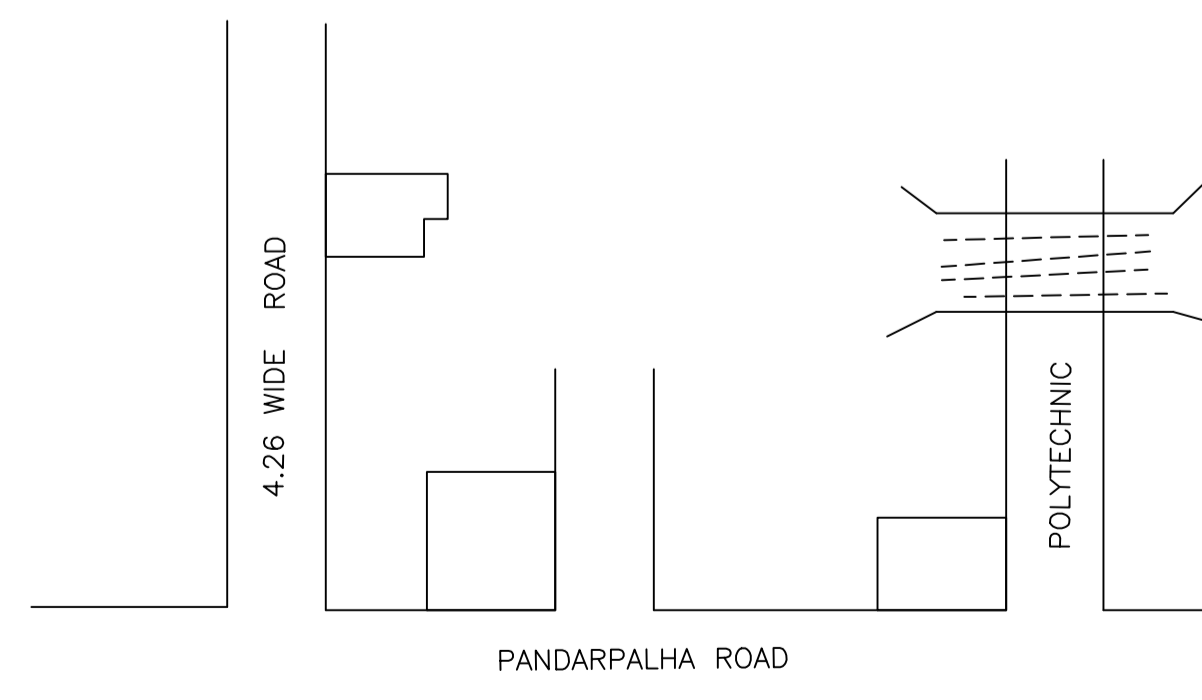

LOCATION PLAN
SCALE - NTS

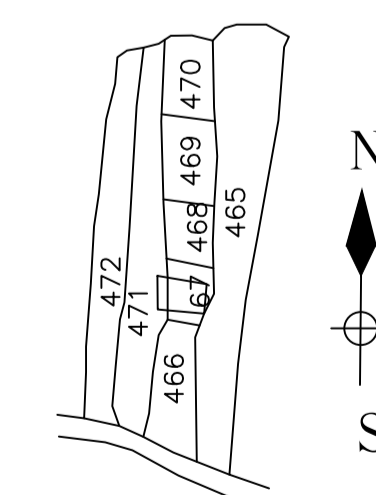

KEY PLAN
SCALE - NTS

LTP NAME AND SIGNATURE	STRUCTURAL ENG'S NAME AND SIGNATURE	BUILDER NAME AND SIGNATURE	DIGITAL SIGNATURE
SANJEEV KUMAR RAY DMC/ENG/0001/2019			