

Project Title :DURGESH NANDINI

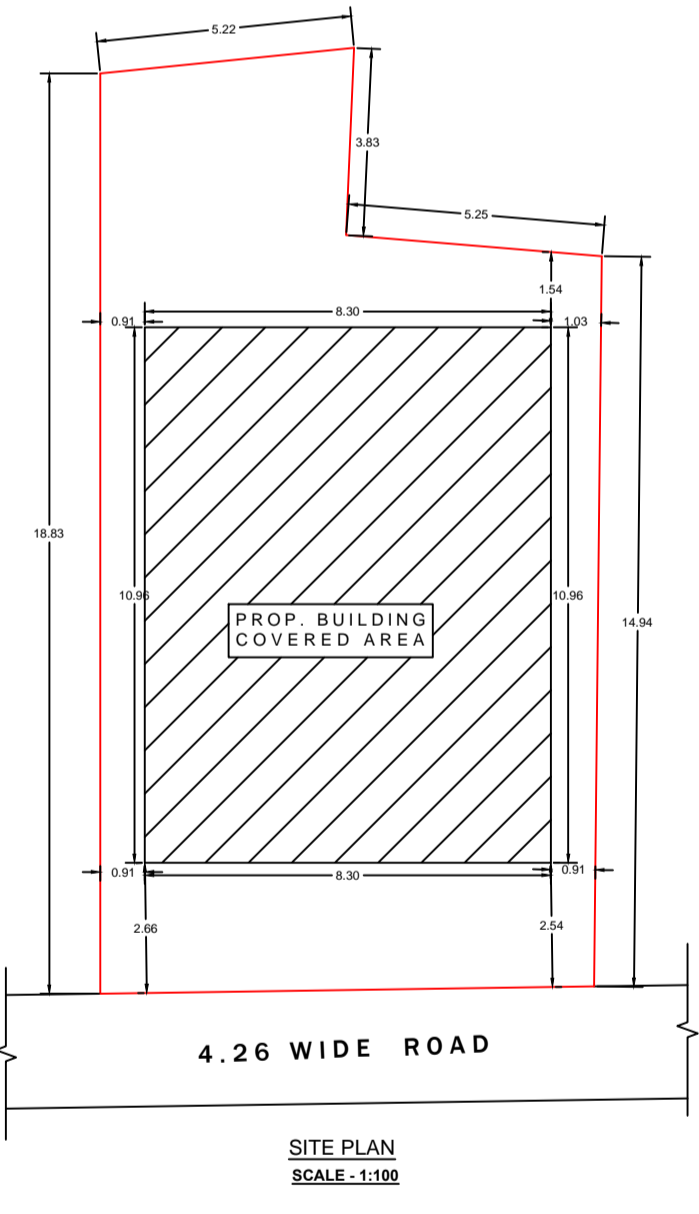
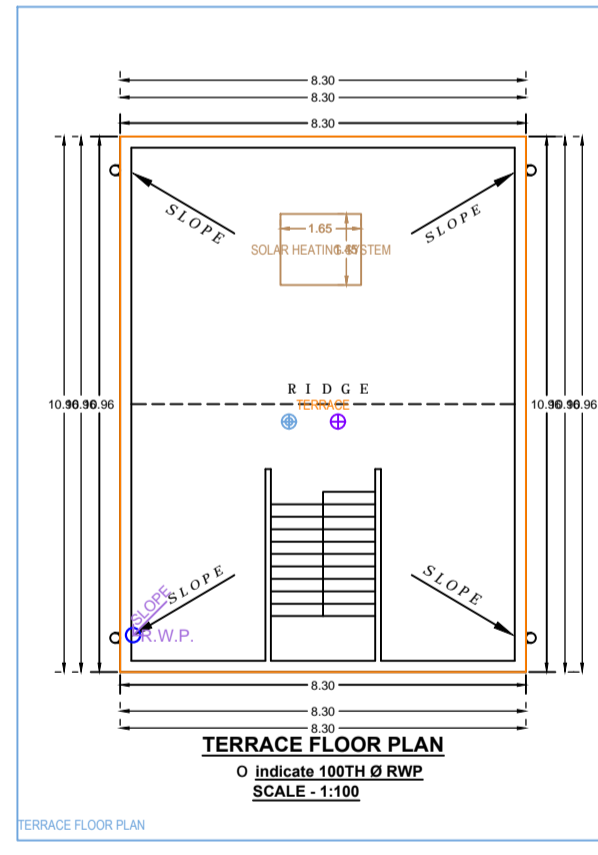
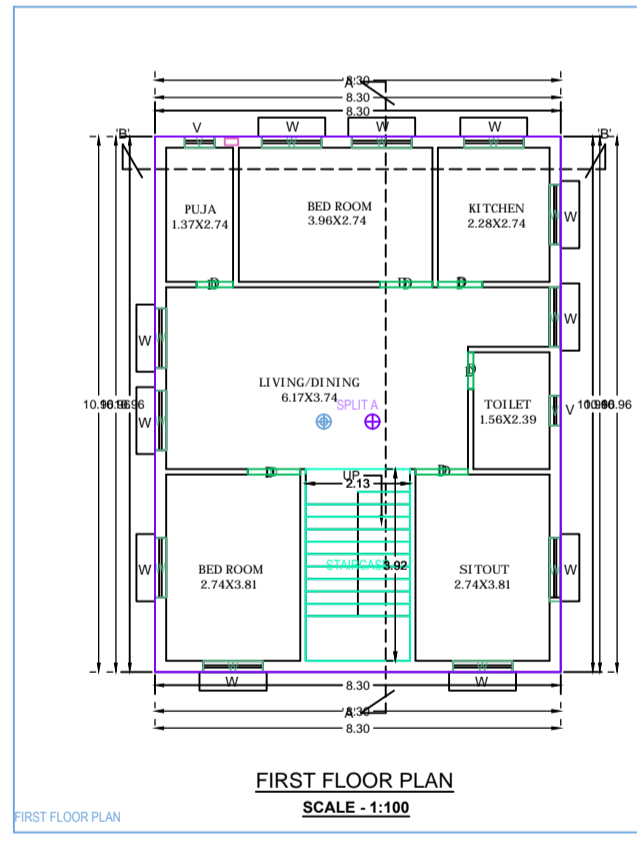
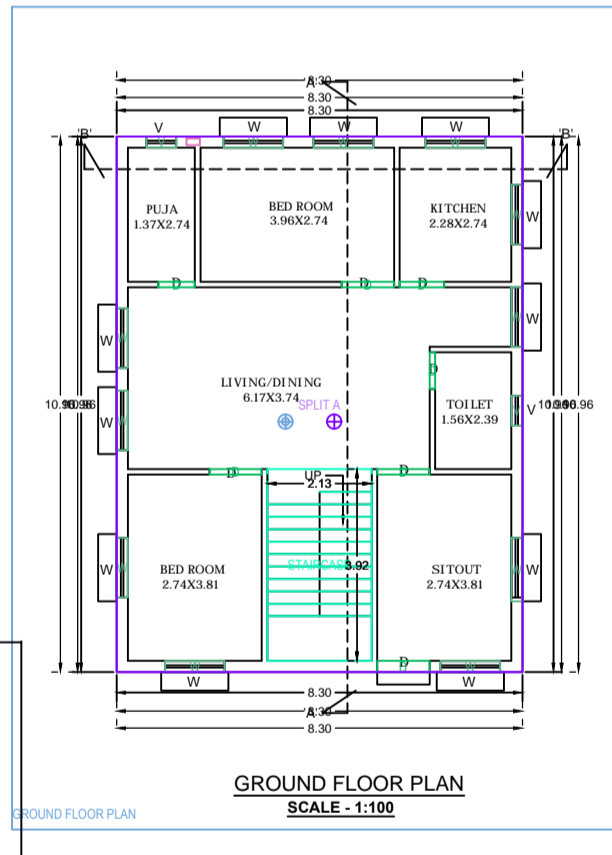
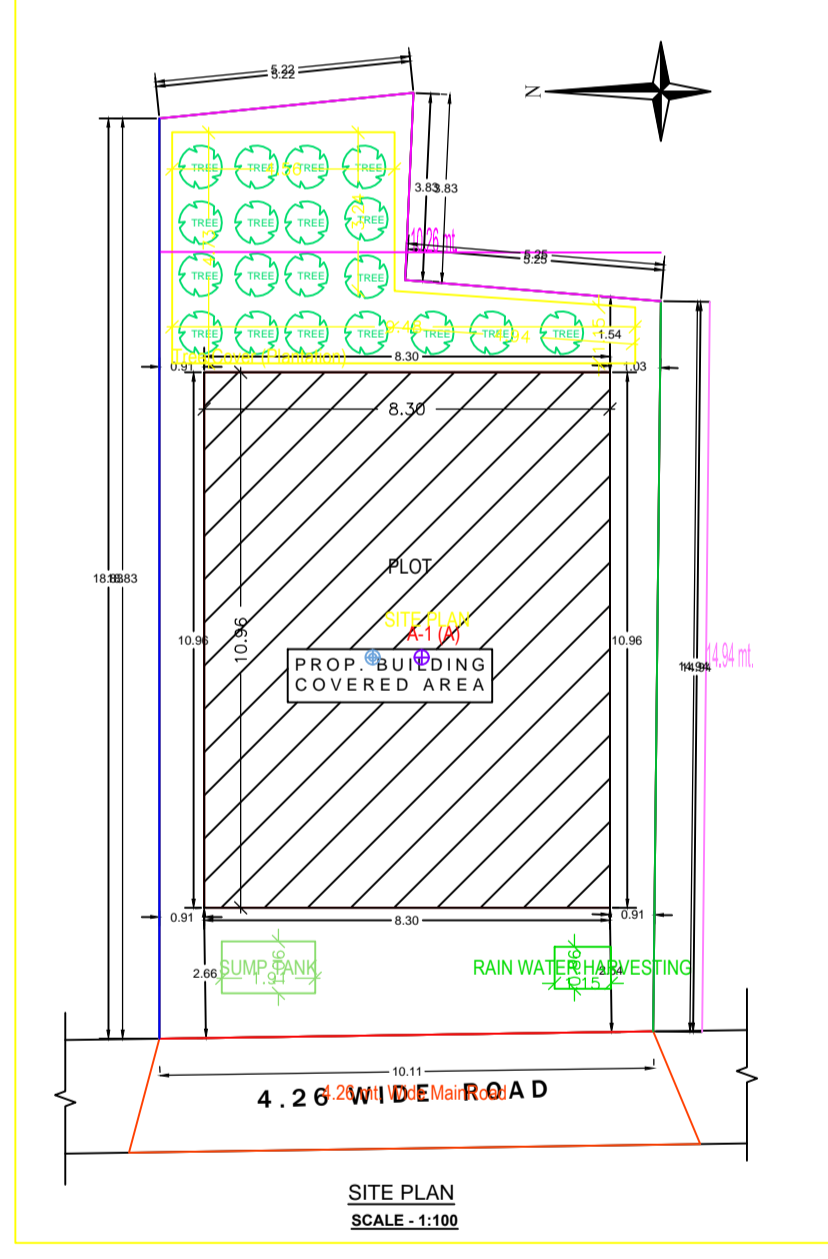
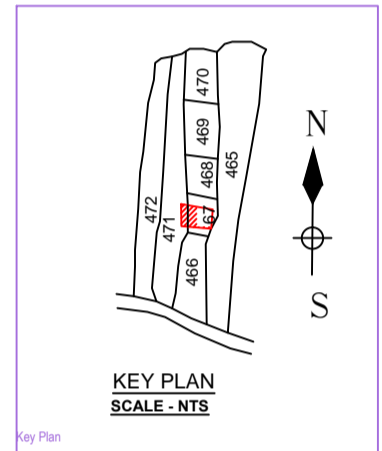
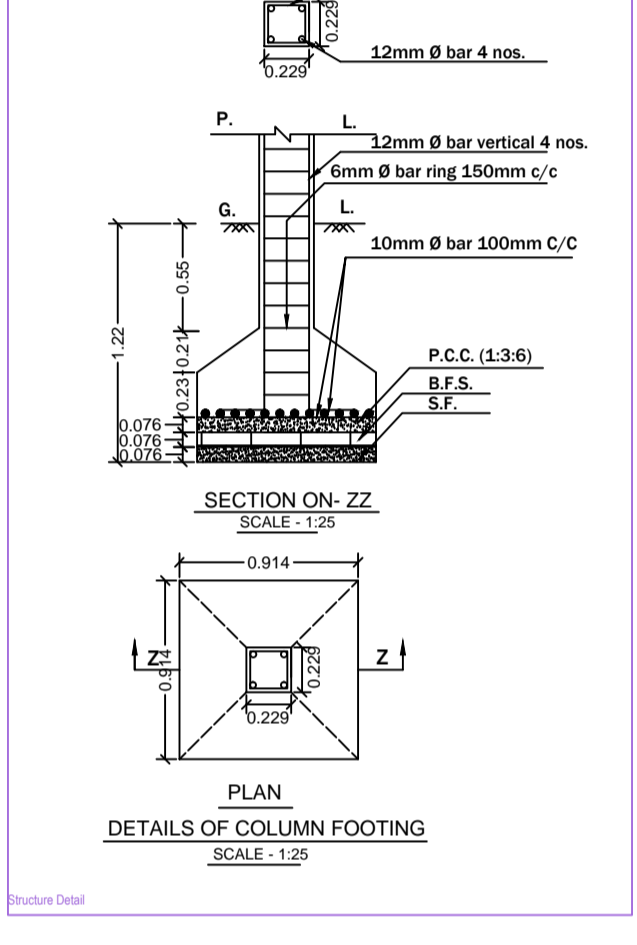
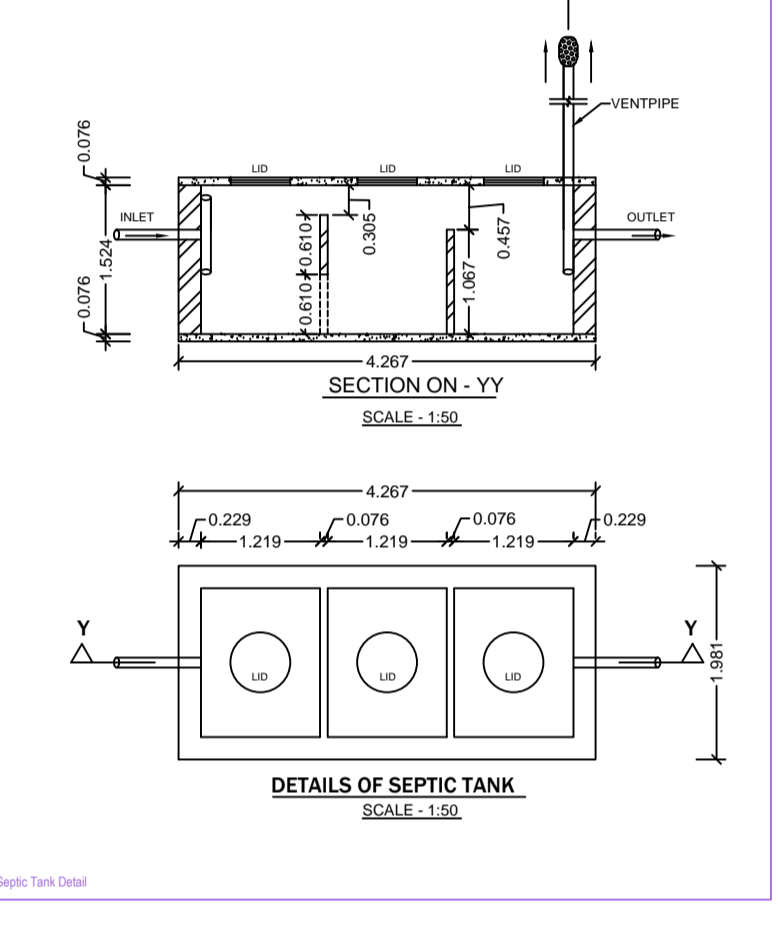
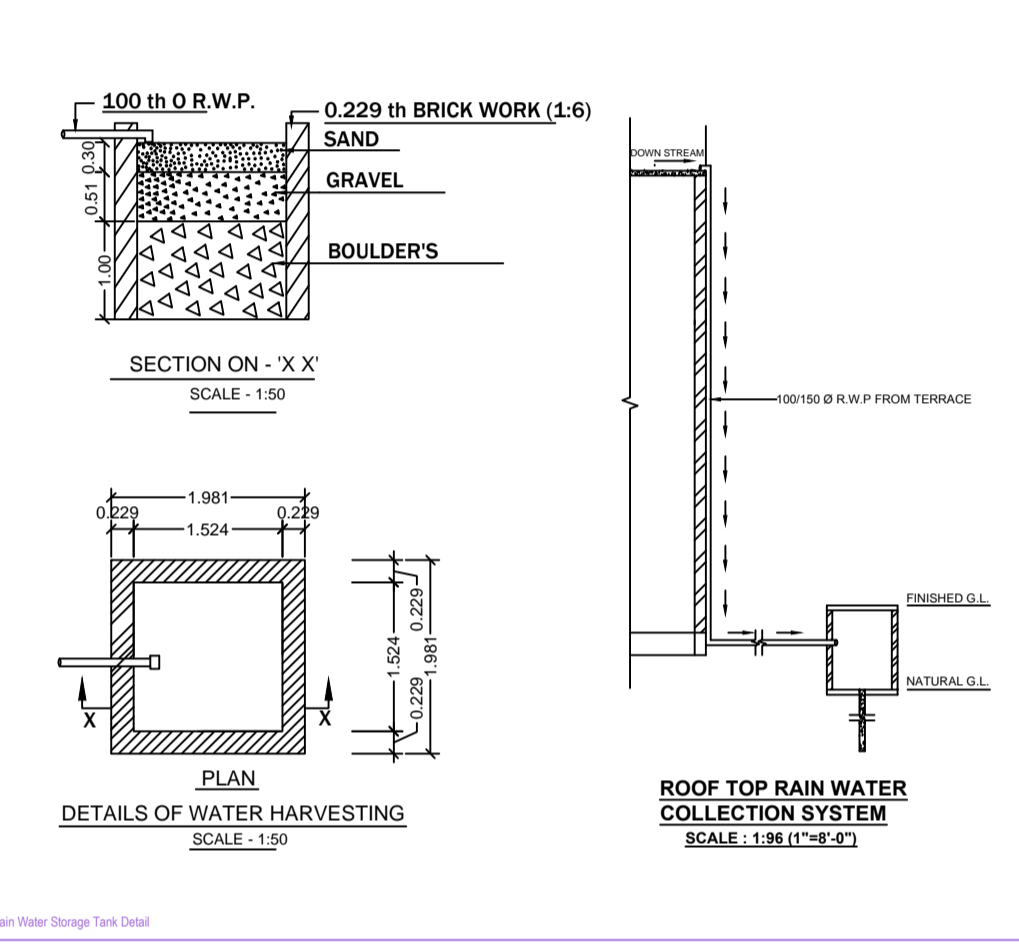
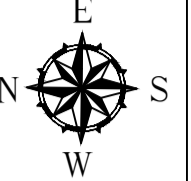
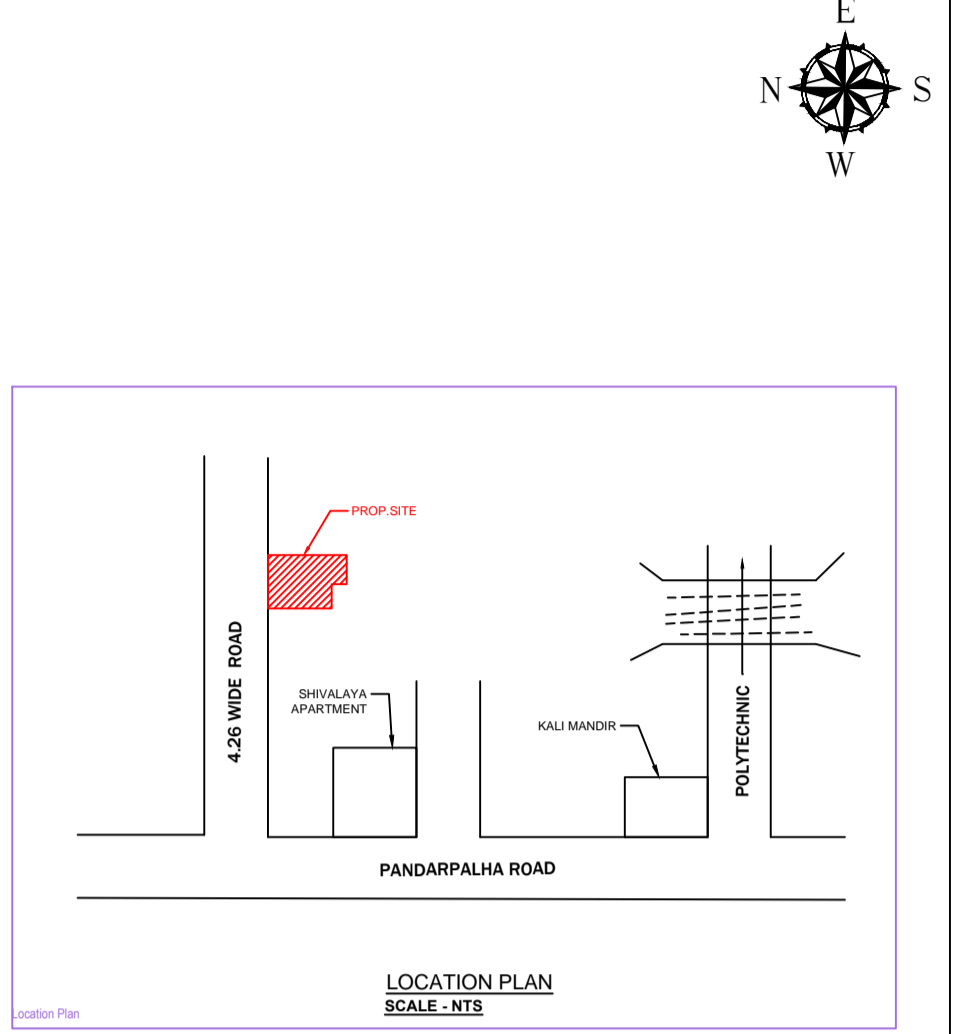
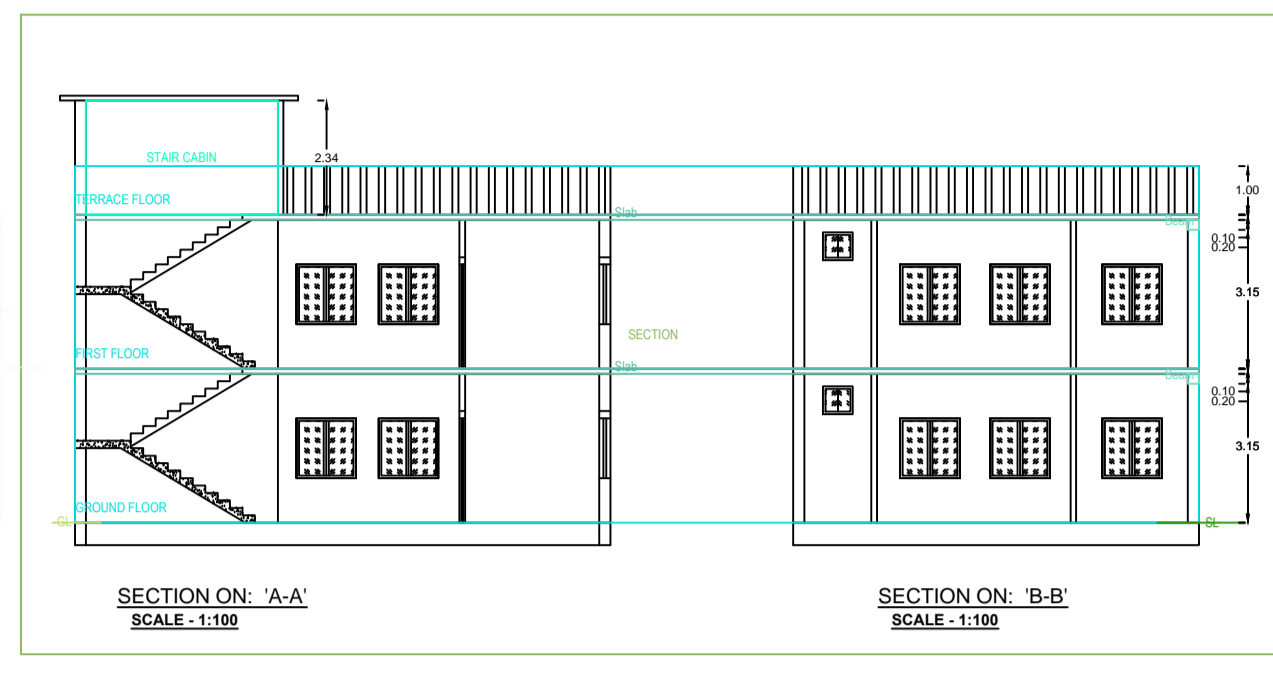
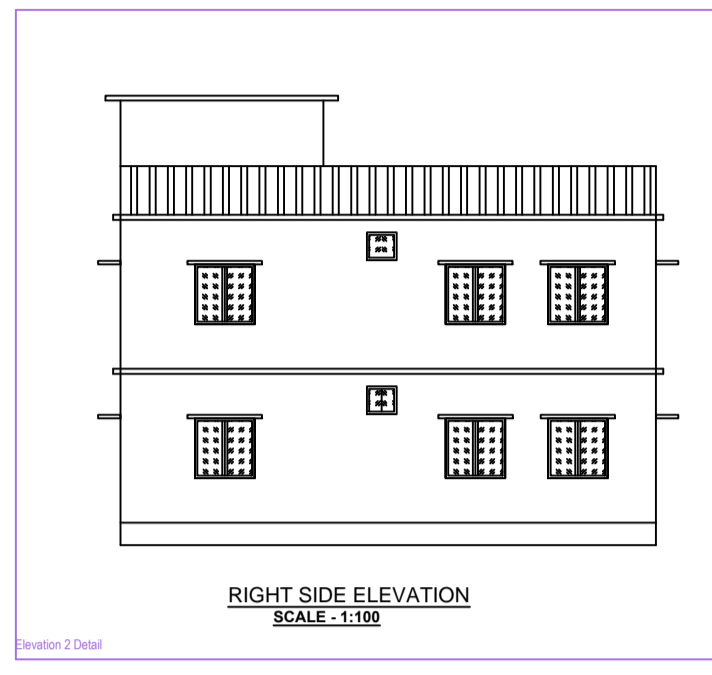
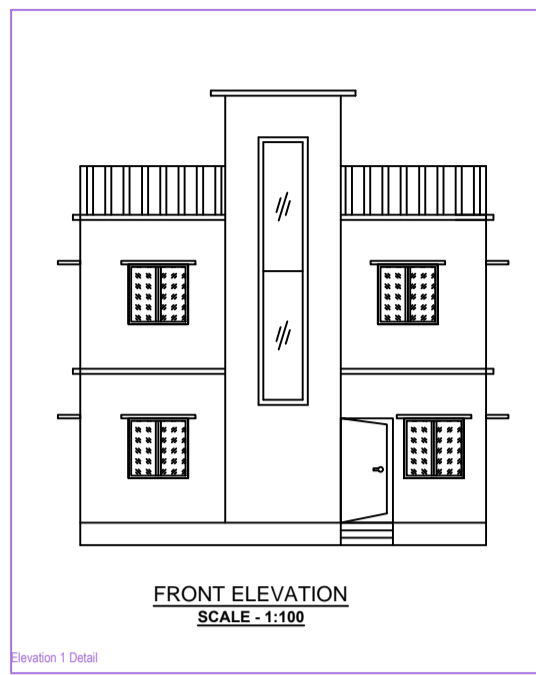

SPECIFICATION

- Dimension : All dimensions are mentioned in Meter otherwise stated.
- Excavation : As per required depth and width below the NGL.
- Foundation : As per detail of Reinforced Concrete Concrete/PCC.
- PCC : As per M-10 Mix Grade with 2" thickness or noted.
- RPC : As per M-15 (1:2:4) Mix Grade with 2" thickness or noted.
- Listed : As per M-15 (1:2:4) or M-20 (1:1.5:3) Mix Grade or either noted.
- RCC : As per M-20 (1:1.5:3) or M-25 (1:1:2) Mix Grade or either noted.
- Steel : As per design and IS - 45 of Sal / Tata or IS mark.
- Brick Work : First Class Brick Work with Cement Mortar 1:4 Mix in Foundation & Superstructure.
- Plaster Work : Cement Mortar 1:4:3:1.5:1.5 Mix in Ceiling, Outer Walls & Inner Walls respectively with 12" thick or noted.
- Painting Work : White Wash / Stonecolor in Outer side Wall and Colour Wash / Oil Bound Discolor in Inner side wall & Ceiling.
- Wood Work : With Sal Wood / Teak Wood or Standard Wood.
- Staircase : RISE - 150mm, TREAD - 250mm
- Scale : 1:100, 1:50, 1:30 & N.T.S.

SCHEDULE OF OPENING

Sl.	DOOR	D	W	Sl.	WINDOW	W
1.	D1	- 0.9mX2.13m		7.	W1	- 1.22MX1.22M
2.	D2	- 0.9mX2.13m		8.	W2	- 0.9MX1.22M
3.	D3	- 0.7mX2.13m		9.		
4.	VENTILATE V	- 0.6mX0.6m		10.	ROOF LEVEL	3.05m
5.				11.		
6.				12.		

DETAILS OF AREA

1) LAND AREA (AS PER DEED):	182.00 Sqm
2) LAND AREA (AS PER SITE):	174.38 Sqm
3) GROUND FLOOR AREA:	90.97 Sqm
4) FIRST FLOOR AREA:	90.97 Sqm
5) TOTAL AREA:	181.94 Sqm
6) % OF PLINTH AREA:	52.10%
7) F.A.R.:	1.04

PROPOSED RESIDENTIAL BUILDING PLAN OF SMT DURGESH NANDINI W/O SRI RAMANUJ CHOUHARY ON PLOT NO- OLD-471,467, NEW-511,153, KHATA NO-OLD-30,54, NEW-646,524, IN MOUZA-PANDARPALHA, MOUZA NO-04, IN DISTRICT OF DHANBAD(JHARKHAND)

SIGNATURE OF OWNER SIGNATURE OF ENGINEER

AREA STATEMENT DHANBAD MUNICIPAL CORPORATION

VERSION NO. 13.36
VERSION DATE: 10-10-2020

PROJECT DETAIL:
 Region : JHARKHAND URBAN LOCAL BODIES
 District : DHANBAD
 Application Type : General Proposal
 Project Type : Building Permission
 Nature of Development : New
 Location : CG Area
 Sub Location : NA
 Village/Mouza Name :
 Ward No :
 Road/Street :
 Eest :
 West :
 North :
 South :
 East :
 West :

AREA DETAILS:
 Gross Plot Area (Sq.Mt) : 174.38
 Net Plot Area (Gross Plot Area - (A) Deductions) : 174.38
 Location of Balance Plot Area (from Gross Plot Area)
 G.P. Area : 28.01
 Total : 28.01
 Balance Plot Area (Net Plot Area - (A) Deductions) : 146.37
 Plot Area for Coverage (Net Plot Area) : (A) Deductions : 174.38
 Plot Area for FAR (Net Plot Area - (A) Deductions) : 174.38
 COVERAGE CHECK
 Proposed Coverage Area (Sq.Ft) % : 90.97
 Total Coverage Area (Sq.Ft) % : 90.97
 FAR CHECK
 Proposed Area of FAR : 181.94
 Total Area of FAR : 181.94
 BUILD UP AREA CHECK
 G.P. Proposed Buildup Area : 181.94
 ARCHT ENGRG / SUPERVISOR (Regd) : OWNER
 DEVELOPMENT AUTHORITY : LOCAL BODY

COLOR INDEX

Color Index Detail:
 Building / Wing Name : Road Name : Front Margin : Rear Margin : Side Margin : Side Margin
 A / (A) : 4.26 mt. Wide Road : 2.54 : 1.53 : 0.91 : 0.91

FAR & Tenement Details (Table 4c-1)

Building	No. of Same Bldg	Total Built Up Area (Sq.Mt)	Proposed FAR Area (Sq.Mt) Reg.	Total FAR Area (Sq.Mt)	Tenent (No.)
A / (A)	1	181.94	181.94	181.94	01
Grand Total	1	181.94	181.94	181.94	01

Building -A (A)

Floor Name	Total Built Up Area (Sq.Mt)	Proposed FAR Area (Sq.Mt) Reg.	Total FAR Area (Sq.Mt)	Tenent (No.)
Ground Floor	90.97	90.97	90.97	01
First Floor	90.97	90.97	90.97	00
Terrace Floor	0.00	0.00	0.00	00
Total	181.94	181.94	181.94	01
Total Number of Same Buildings	1			
Total	181.94	181.94	181.94	01

SCHEDULE OF JOINERY:

BUILDING NAME	NAME	LENGTH	HEIGHT	NOS
A / (A)	D	0.75	2.10	04
A / (A)	D	0.91	2.10	02
A / (A)	D	1.07	2.10	07
Total	-	-	-	13

SCHEDULE OF JOINERY:

BUILDING NAME	NAME	LENGTH	HEIGHT	NOS
A / (A)	V	0.61	1.00	04
A / (A)	W	1.22	1.30	20
A / (A)	W	1.30	1.20	02
Total	-	-	-	26

UnitBUA Table for Building -A (A)

FLOOR	Name	UnitBUA Type	UnitBUA Area	Carpet Area	No. of Rooms	No. of Tenement
GROUND FLOOR PLAN	SPLIT A	FLAT	181.94	181.86	8	1
Total	-	-	181.94	181.86	16	1