

Project Title :SEEMA SRIVASTAVA

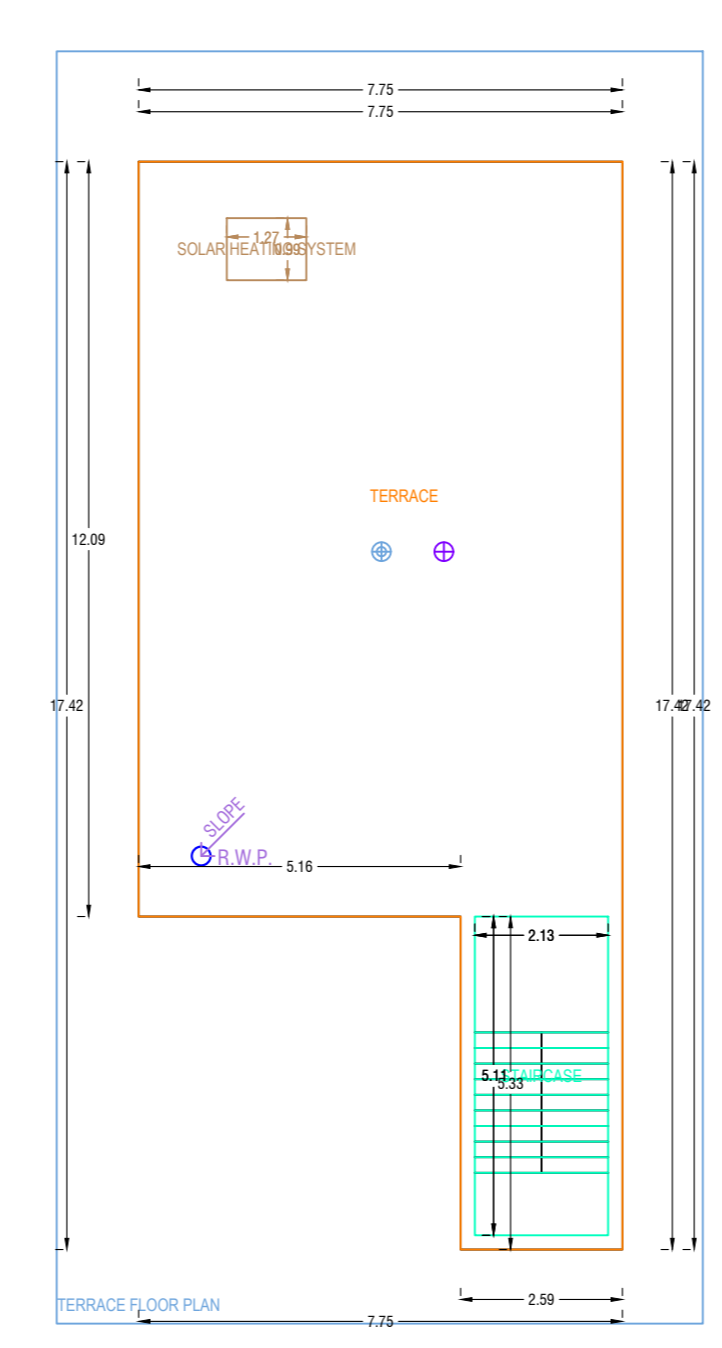
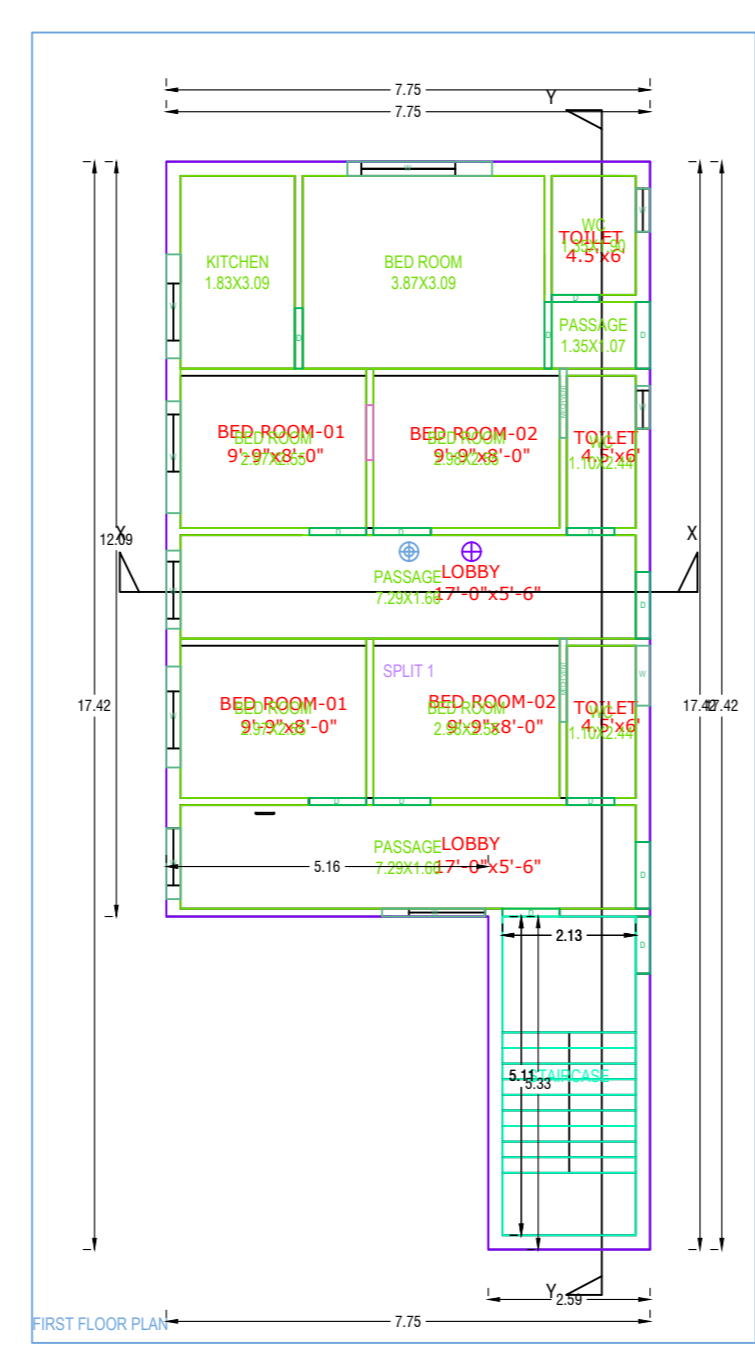
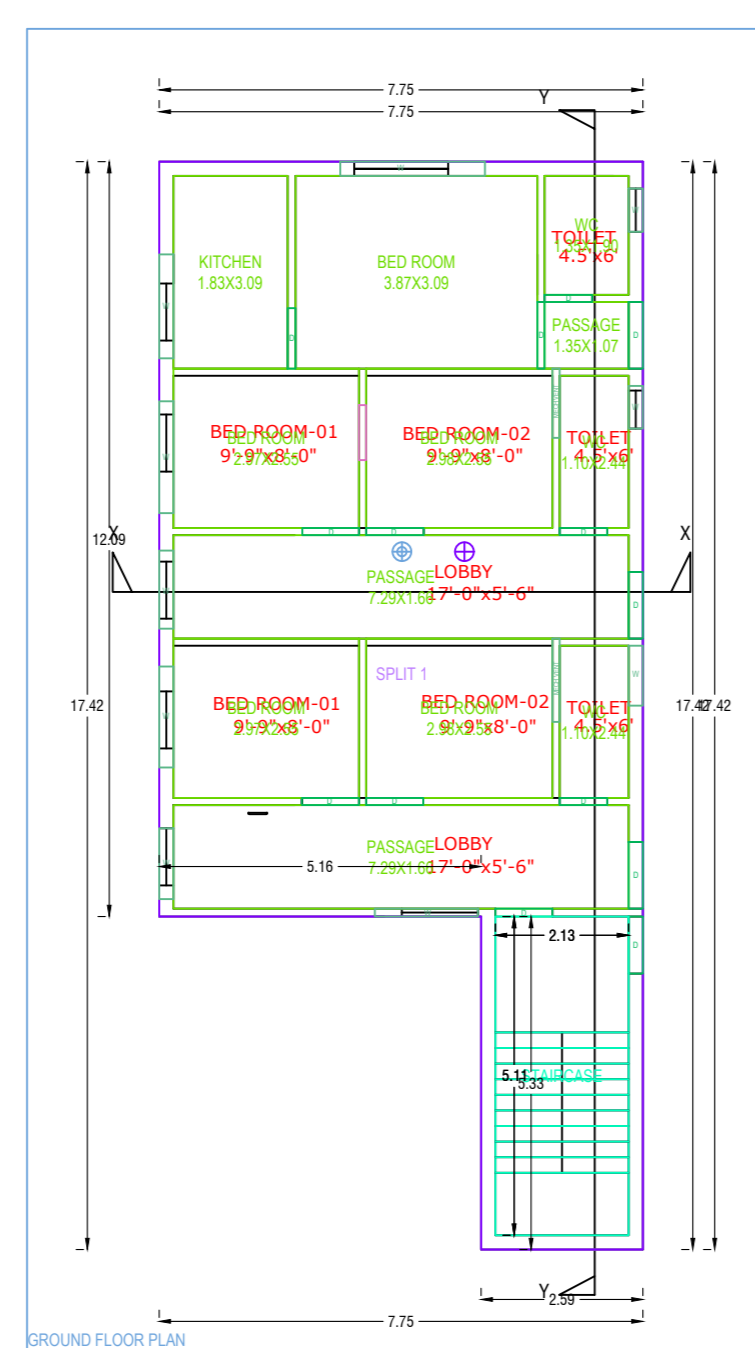
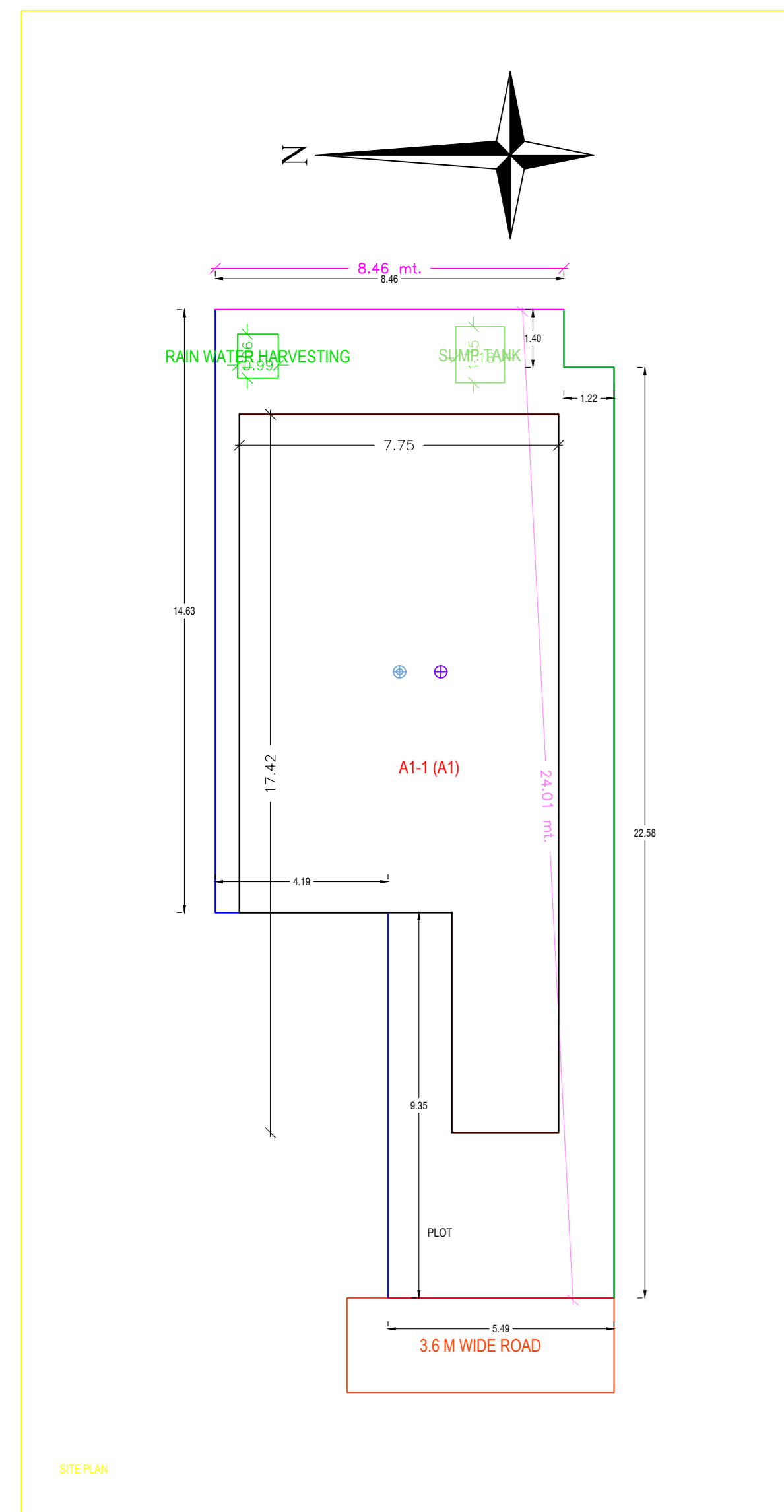
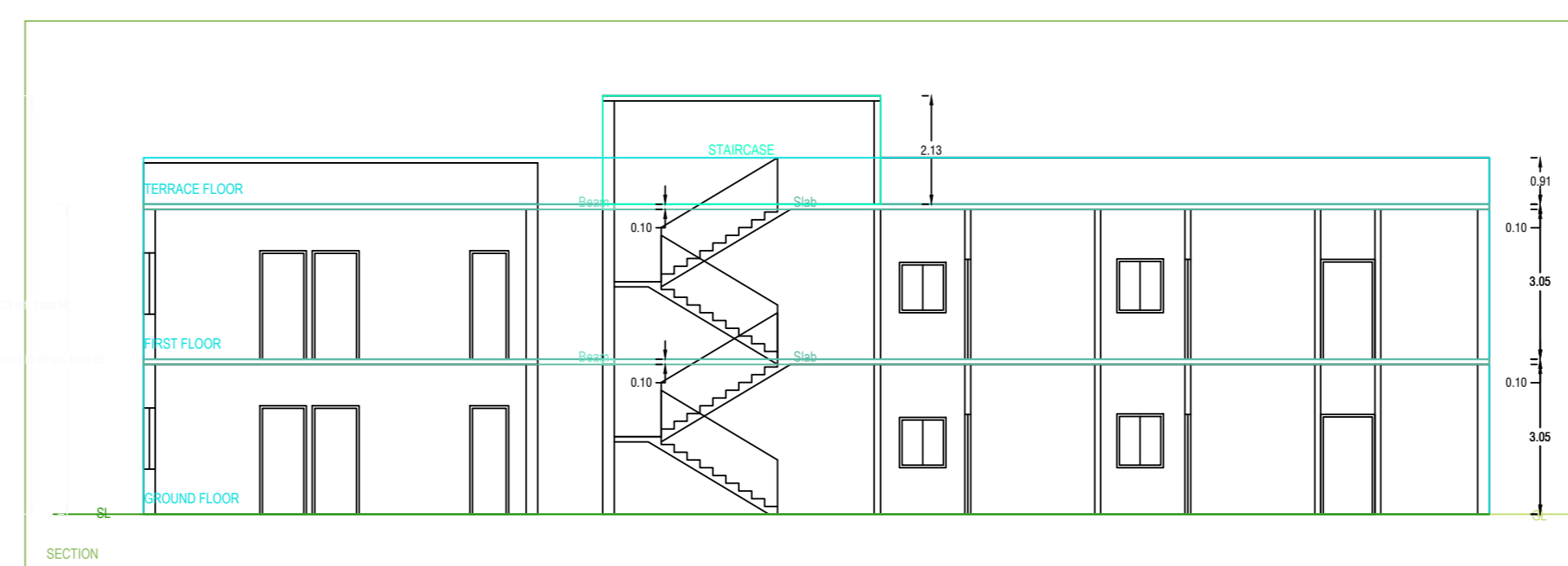
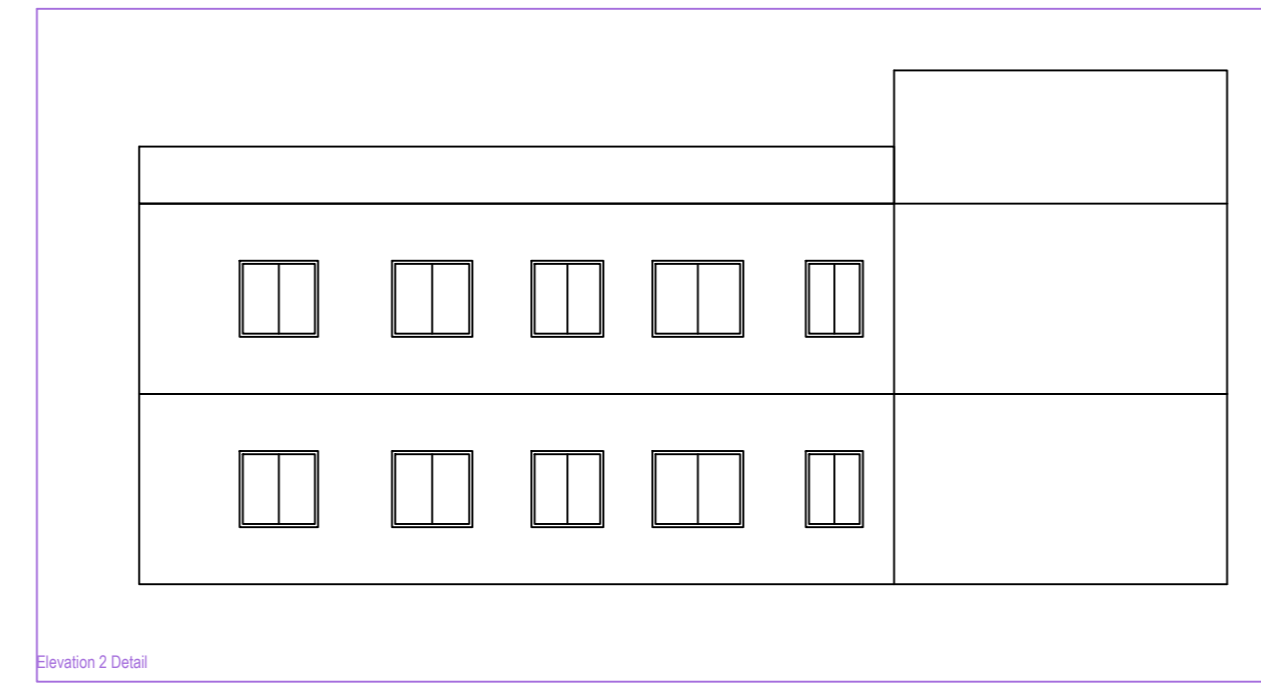
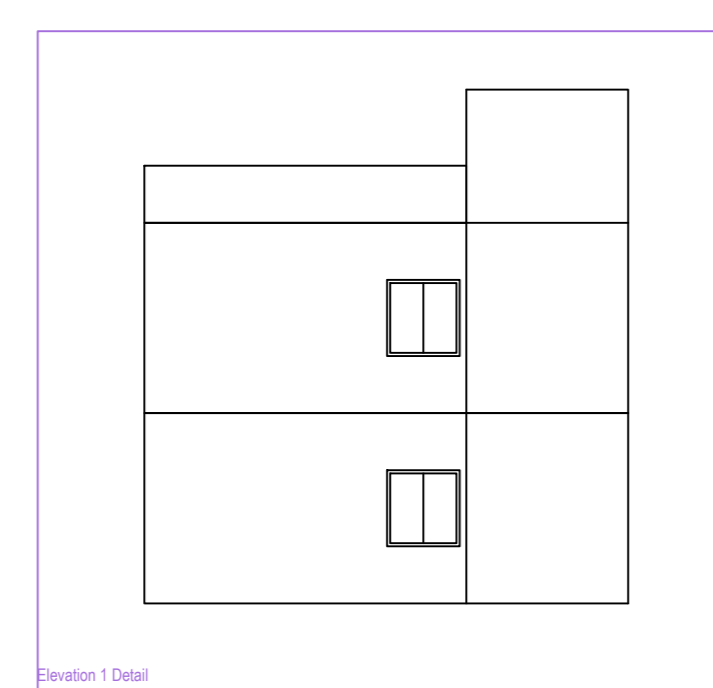
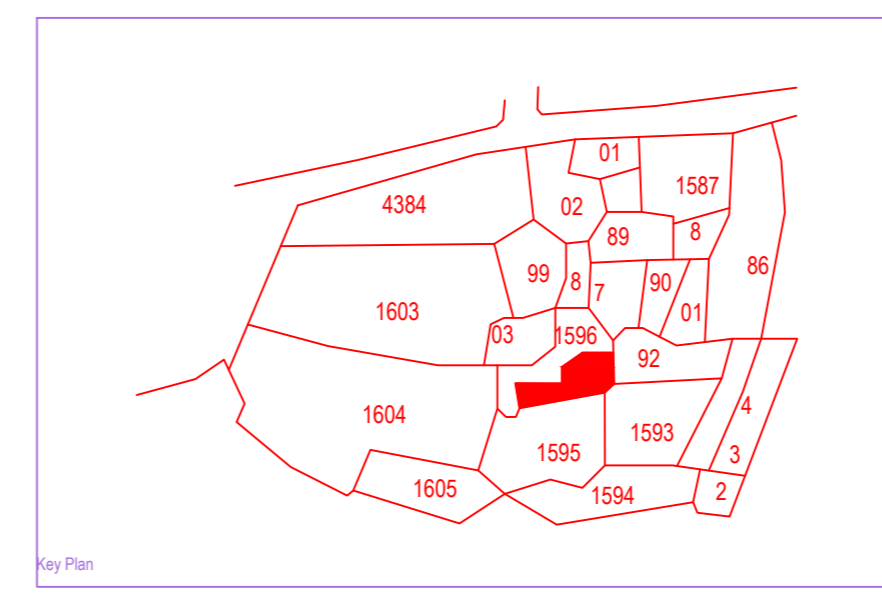
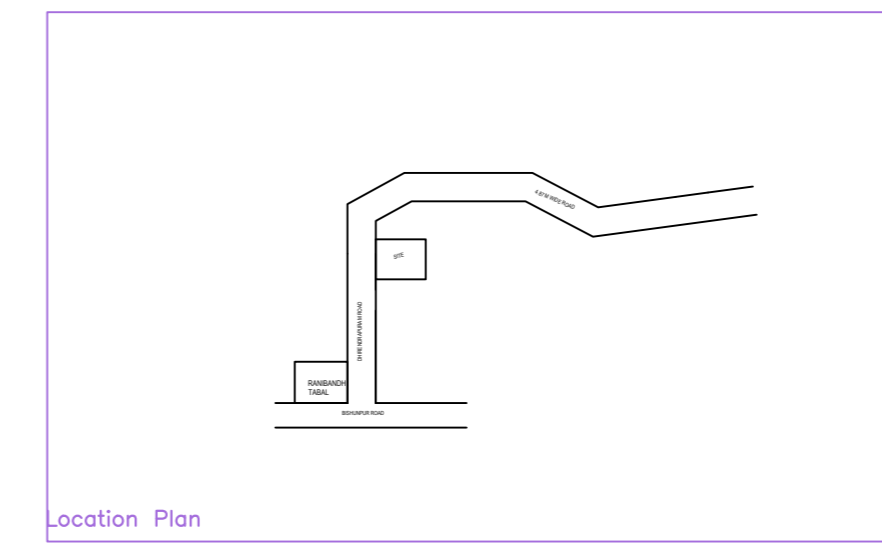
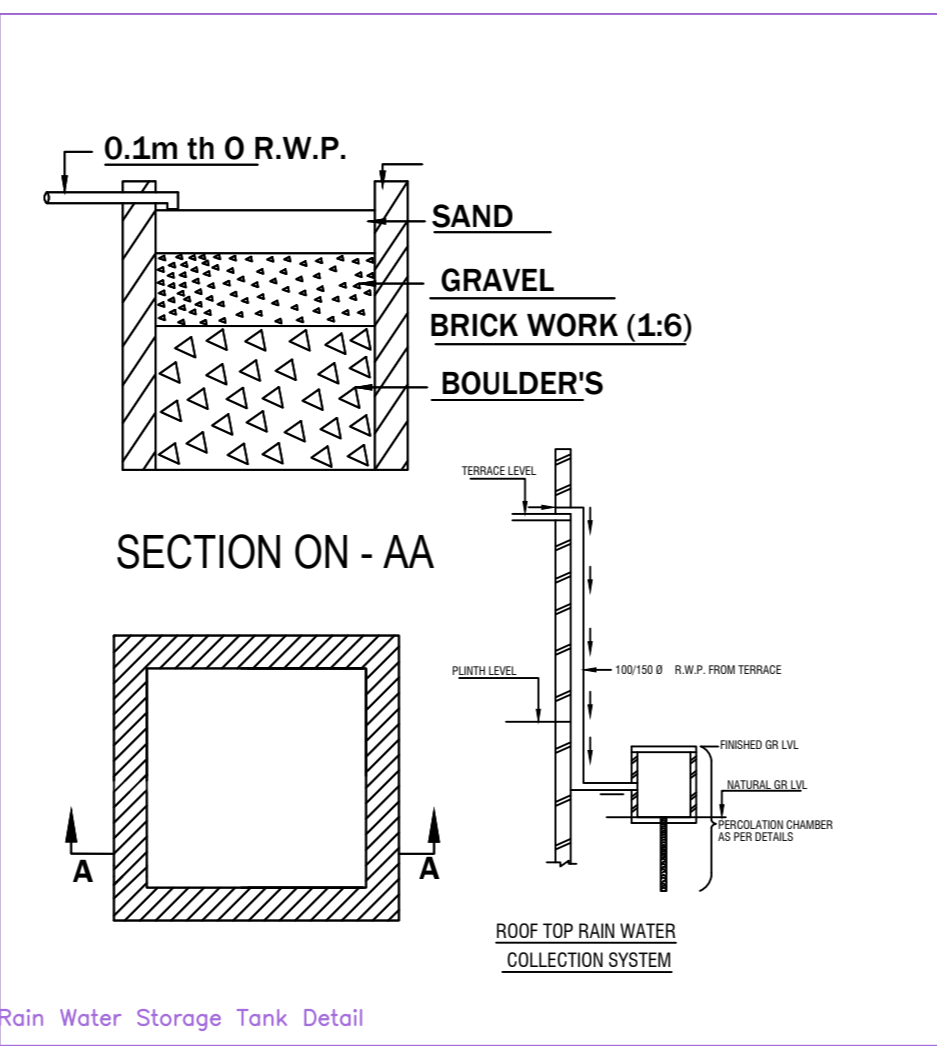
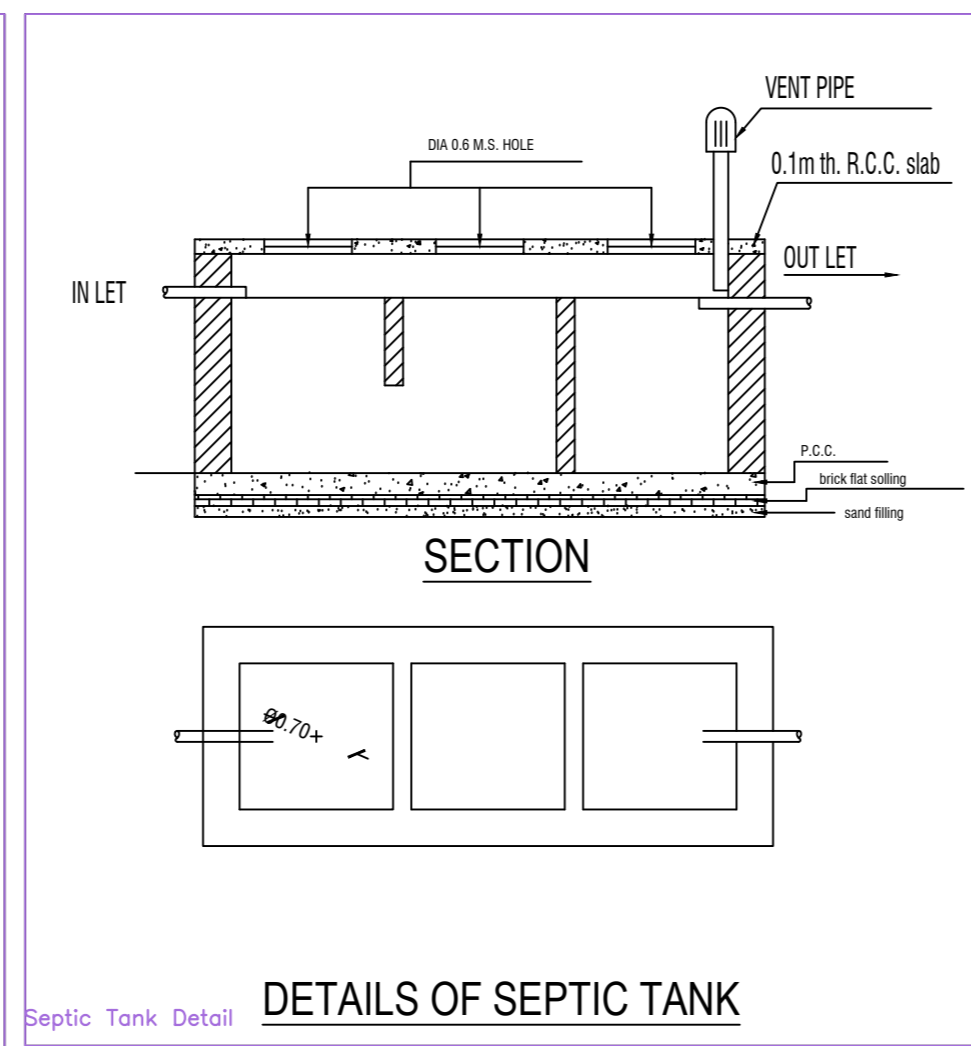
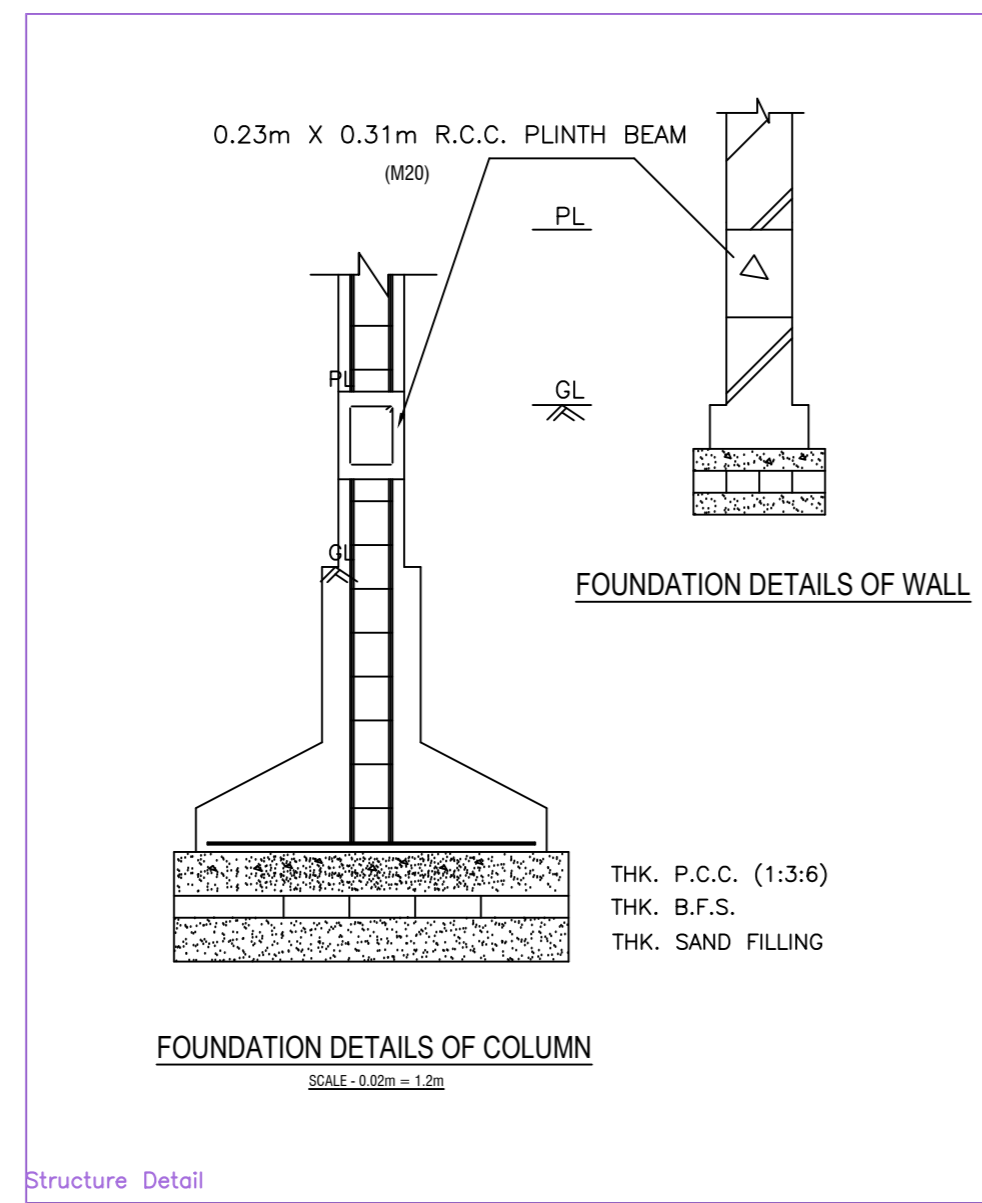

Building A1 (A1)

Floor Name	Total Built Up Area (Sq.Mt)	Proposed FAR Area (Sq.Mt)	Total FAR Area (Sq.Mt)	Trees (No.)
Ground Floor	107.48	107.48	107.48	01
First Floor	107.48	107.48	107.48	00
Terrace Floor	0.00	0.00	0.00	00
Total	214.96	214.96	214.96	01
Total Number of Same Buildings	1	214.96	214.96	01

SCHEDULE OF JOINERY:

BUILDING NAME	NAME	LENGTH	HEIGHT	NOS
AT(A1)	D	0.76	2.10	06
AT(A1)	D	0.91	2.10	01
AT(A1)	D	0.92	2.10	02
AT(A1)	D	0.97	2.10	02
AT(A1)	D	1.07	2.10	08
Total	-	-	-	28

SCHEDULE OF JOINERY:

BUILDING NAME	NAME	LENGTH	HEIGHT	NOS
AT(A1)	W	0.98	1.20	02
AT(A1)	W	0.89	1.20	02
AT(A1)	W	0.96	1.20	02
AT(A1)	MECH-VENT	1.11	1.00	02
AT(A1)	W	1.10	1.00	02
AT(A1)	W	1.25	1.20	02
AT(A1)	MECH-VENT	1.33	1.00	02
AT(A1)	W	1.62	1.20	02
AT(A1)	W	1.65	1.20	02
AT(A1)	W	1.66	1.20	02
AT(A1)	W	1.79	1.20	02
AT(A1)	W	2.32	1.20	02
Total	-	-	-	24

Unibuild Table for Building -A1 (A1)

FLOOR	Name	Unibuild Type	Unibuild Area (Sq.Mt)	Carpet Area (Sq.Mt)	No. of Rooms	No. of Tenement
GROUND FLOOR	SPLIT 1	FLAT	214.97	214.77	12	1
Total	-	-	214.97	214.77	24	1

AREA STATEMENT: DHANBAD MUNICIPAL CORPORATION

PROJECT DETAIL:

Project No.	PL Use - Residential
Region	SHARAWAD URBAN LOCAL BODIES
District	DHANBAD
Application Type	General Proposal
Project Type	Building Permission
Name of Development	New
Location	Old Area
Sub Location	NA
Map/Block Name	-
Word No.	-
Block/Sheet	-
East	-
West	-

AREA DETAILS:

AREA OF PLOT (Sqm)	10	191.16
Net Plot Area (Sqm)	(A-Deduction)	191.16
Deduction from Green Plot Area	(A-Deduction)	191.16
Balance Plot Area (Net Plot Area)	(A-Deduction)	191.16
Plot Area to Coverage (Net Plot Area)	(A-Deduction)	191.16
Plot Area to FSI (Net Plot Area - Road/Opening Area)	(A-Deduction)	191.16

COVERAGE CHECK:

Proposed Coverage Area (98.25 %)	107.48
Total Coverage Area (98.25 %)	107.48

FAR CHECK:

Proposed FAR	214.96
Total FAR	214.96

BUILT UP AREA CHECK:

Total Proposed Built Up Area	214.96
OWNER	
DEVELOPMENT AUTHORITY	LOCAL BODY

COLOR INDEX:

Color Index	
Color Index	
Color Index	
Color Index	

MARGIN DETAIL:

Burging	Road Name	Front Margin	Rear Margin	Side Margin	Shed Margin
AT(A1)	3.6 M WIDE ROAD	4.51	2.54	0.00	1.14

FAR & Tenement Details (Table 4c-1)

Burging	No. of Same Bldg	Total Built Up Area (Sq.Mt)	Proposed FAR Area (Sq.Mt)	Total FAR Area (Sq.Mt)	Trees (No.)
AT(A1)	1	214.96	214.96	214.96	01
Grand Total	1	214.96	214.96	214.96	01

**BRIEF SPECIFICATION**

FOUNDATION - R.C.C. (1:1.5:3) Column footing foundation.  
**PLINTH** - 12"th R.C.C. (1:1.5:3) all round on plinth level.  
**FLOORING** - 1.5"th Marble. flooring over 3"th P.C.C. (1:3:6).  
**SUPER STRUCTURE** - First class brick work in cement mortar (1:6).  
**SLAB,BEAM, stairs & LINTEL** - All R.C.C. work (1:1.5:3).  
**WOOD WORK** - All door & window frames of sal wood  
**PLASTERING** - 12mm cement plaster (1:6) both side.

**SCHEDULE**

D1 - 1.07 X 2.13	W - 0.9 x 1.22
D2 - 0.9 X 2.13	W1 - 1.22 x 1.22
D3 - 0.76 x 2.13	W2 - 1.5 x 1.22
CG - 1.22 x 2.13	V - 0.61 x 0.61

SIG. OF OWNER

SIG. OF ENGINEER