

Project Title :SHYAM NARAYAN SINGH AND OTHER

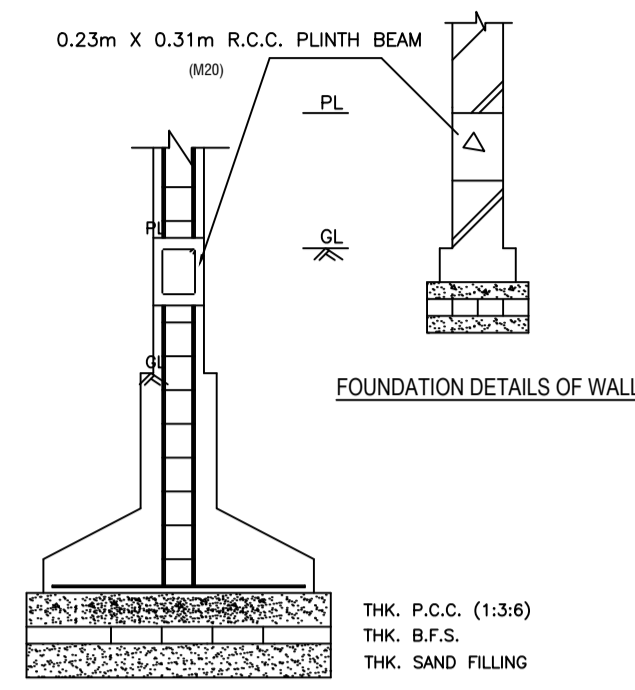

Structure Detail

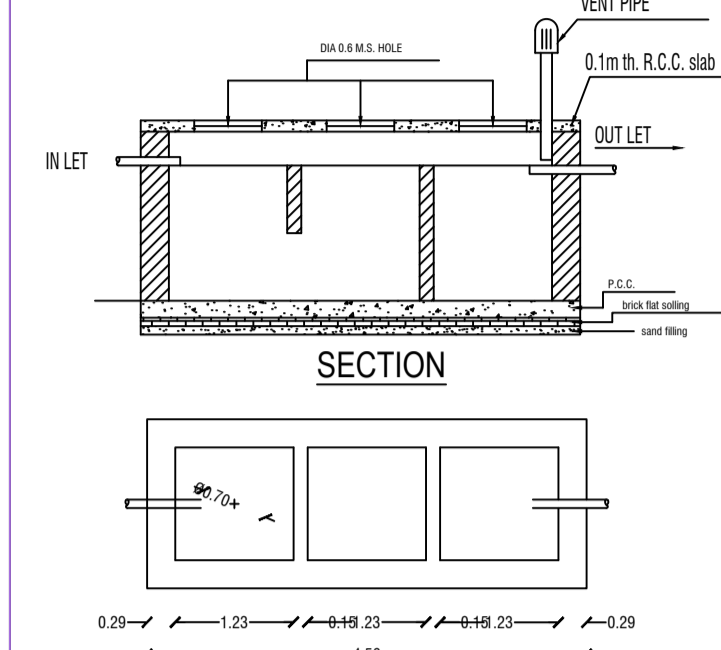

Septic Tank Detail

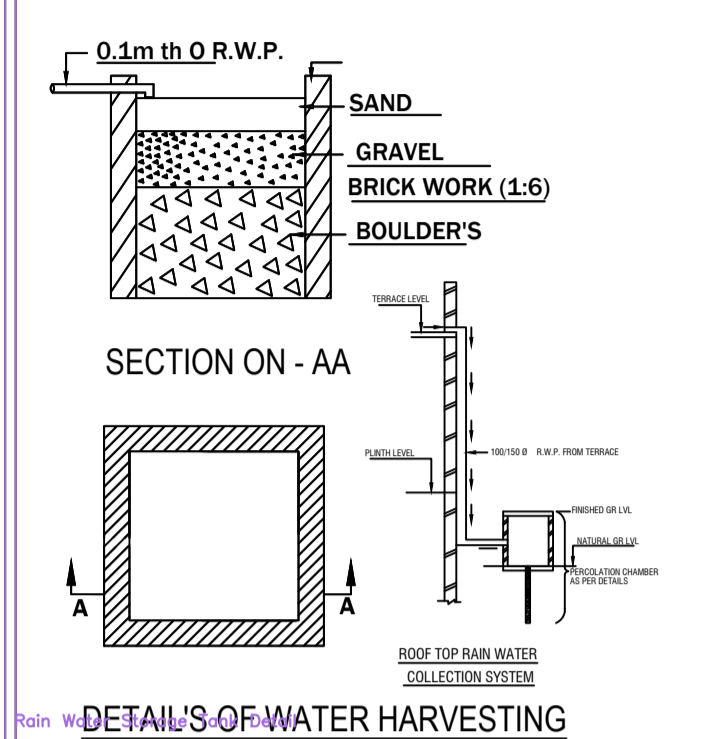

Rain Water Harvesting Detail

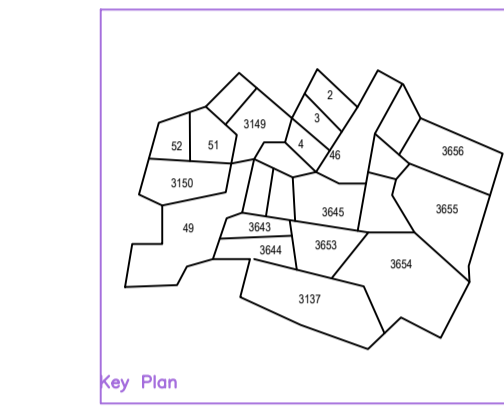
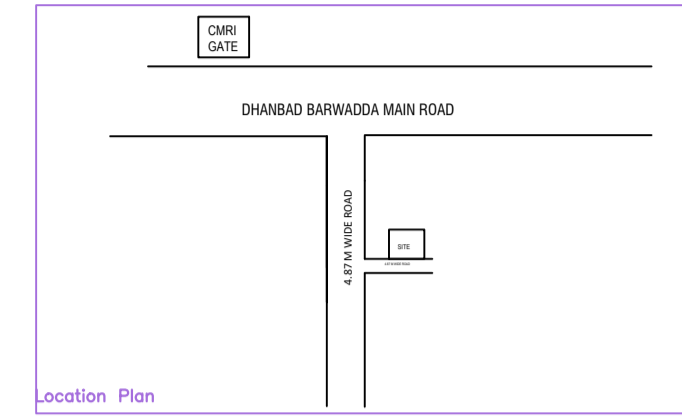

Key Plan

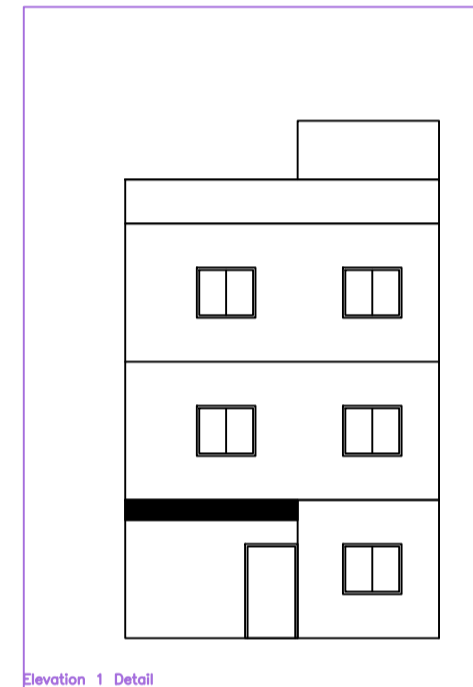

Elevation 1 Detail

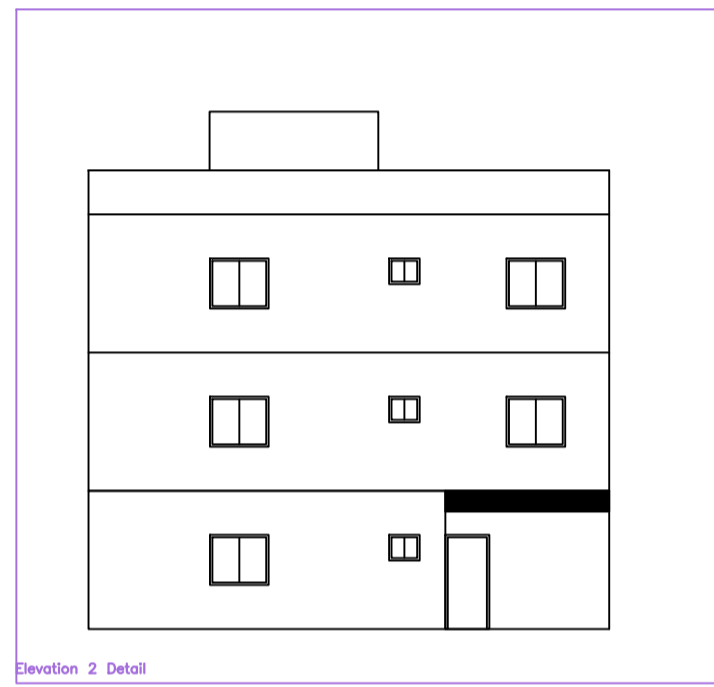

Elevation 2 Detail

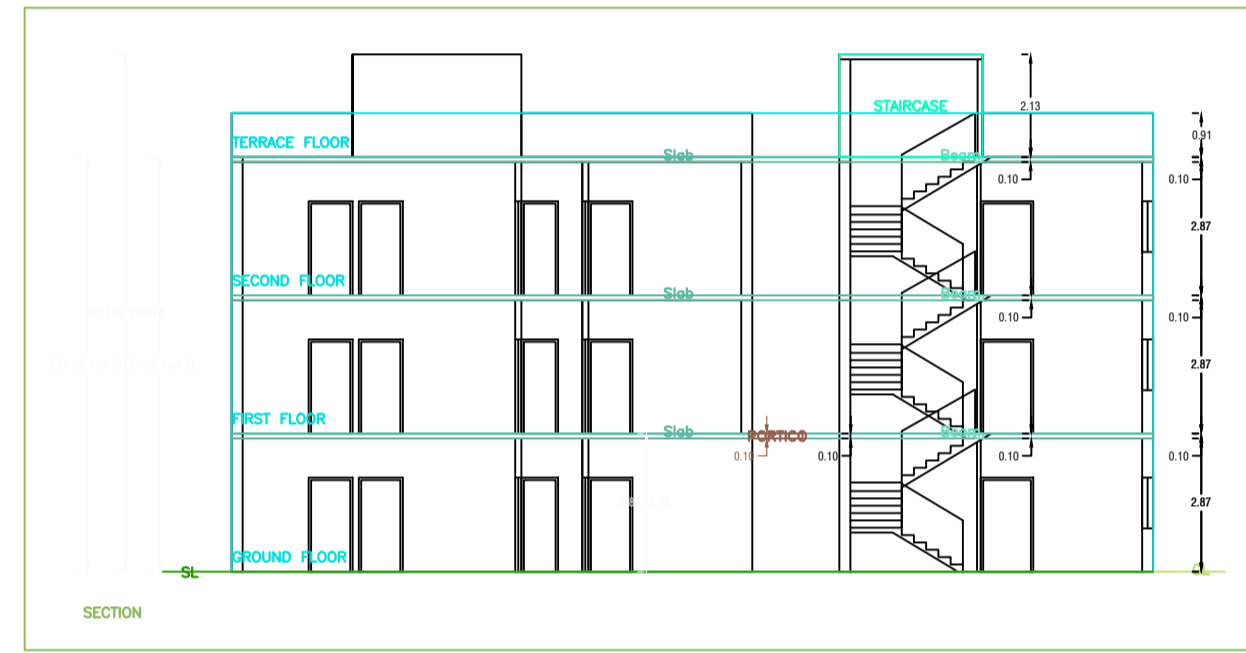

SECTION

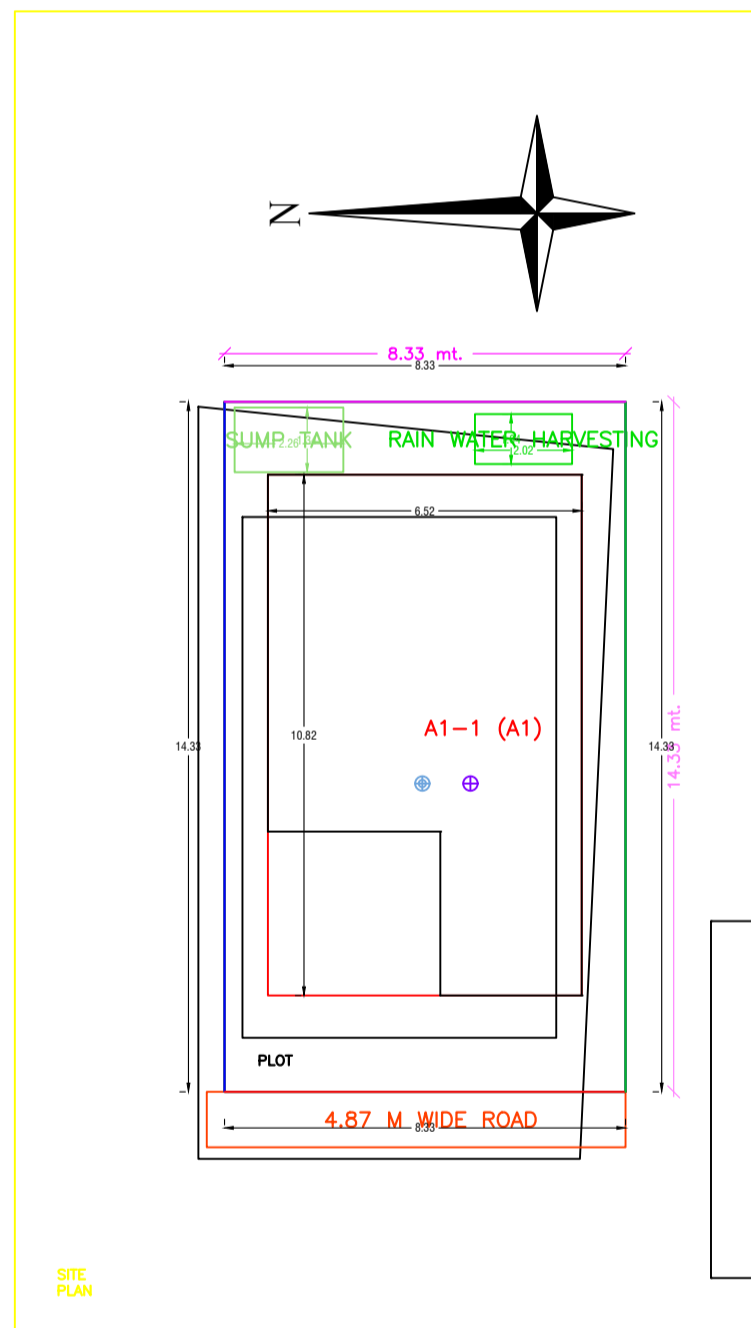

SITE PLAN

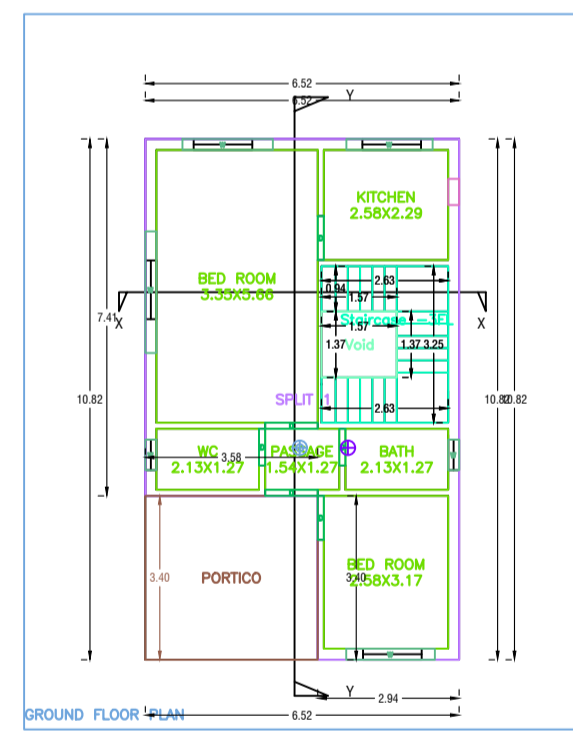

GROUND FLOOR PLAN

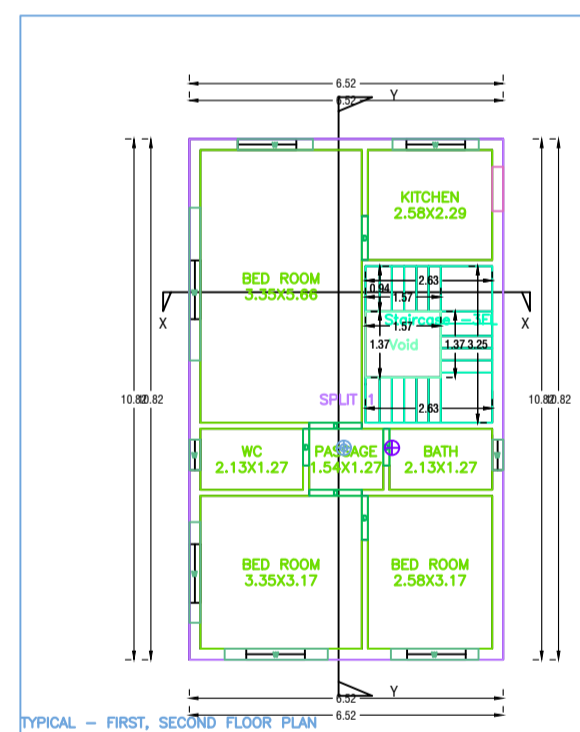

TYPICAL - FIRST, SECOND FLOOR PLAN

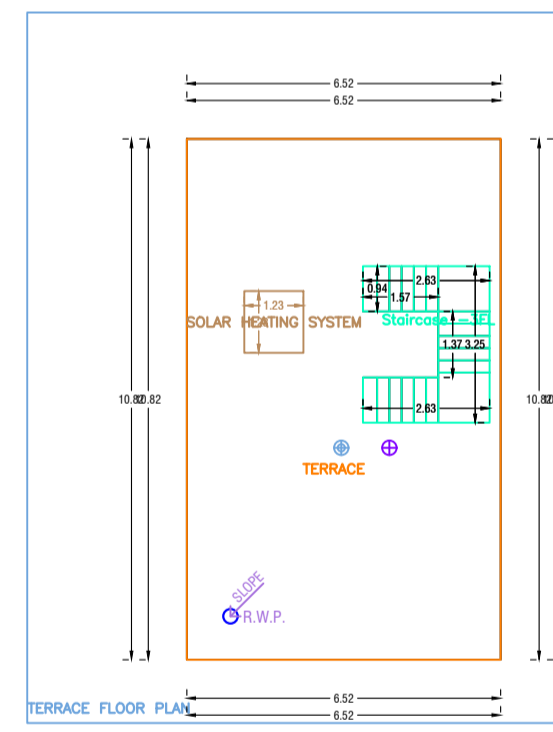

TERRACE FLOOR PLAN

Floor Name	Total Built Up Area (Sq.mt)	Deductions (Area in Sq.mt)		Proposed FAR Area (Sq.mt)	Total FAR Area (Sq.mt)	Tent (No.)
		Void	Arch.Prg.			
Ground Floor	70.50	2.53	0.00	67.97	65.44	01
First Floor	70.50	2.53	0.00	67.97	65.44	00
Second Floor	70.50	2.53	0.00	67.97	65.44	00
Terrace Floor	0.00	0.00	0.00	0.00	0.00	00
Total	211.50	6.45	12.19	192.86	192.86	01
Total Number of Same Buildings	1					
Total	211.50	6.45	12.19	192.86	192.86	01

BUILDING NAME	NAME	LENGTH	HEIGHT	NOS
AT (A1)	D	0.76	2.10	06
AT (A1)	D	0.91	2.10	06
AT (A1)	D	1.09	2.10	06
Total	-	-	-	18

BUILDING NAME	NAME	LENGTH	HEIGHT	NOS
AT (A1)	W	0.63	1.20	06
AT (A1)	W	1.36	1.20	02
AT (A1)	W	1.79	1.20	03
AT (A1)	W	1.82	1.20	02
AT (A1)	W	1.84	1.20	01
AT (A1)	W	1.88	1.20	01
AT (A1)	W	2.09	1.20	02
AT (A1)	W	2.14	1.20	02
AT (A1)	W	2.23	1.20	01
AT (A1)	W	3.17	1.20	02
Total	-	-	-	22

FLOOR	Name	Utilized Area	Unutilized Area	Carpet Area	No. of Rooms	No. of Tenement
GROUND FLOOR PLAN	SPUT 1	FLAT	124.91	124.18	6	1
Total	-	-	124.91	124.18	20	1

AREA STATEMENT DHARBAD MUNICIPAL CORPORATION		VERSION NO. 1.0.37
PROJECT NO.	16/10/2020	
Region - DHARBAD (URBAN LOCAL BODIES)	Plot Use - Residential	
Project - DHARBAD	Plot Sub-Use - Bungalow/Dwelling / Non Apartment	
Application Type - General Proposal	Land Use Zone - UH	
Project Name - Building Permission	Abutting Road Width -	
Nature of Development - New	Revised Survey No/Survey No -	
Location - Old Area	Thana No -	
Site Location -	Holding No -	
Village/Muza Name -	Chute No -	
Ward No -	North -	
Neighbourhood -	South -	
	East -	
	West -	

AREA DETAILS		SO MT
AREA OF PLOT (Minimum)	(A)	119.37
Net Plot Area (Less Plot Area Deduction from Gross Plot Area)	(A-Deductions)	119.37
Balance Plot Area (Net Plot Area - Non-Residential/Other Area)	(A-Deductions)	119.37
Plot Area for Coverage (Net Plot Area)	(A-Deductions)	119.37
Plot Area for FSI (Net Plot Area - Residential Area)	(A-Deductions)	119.37
COVERAGE CHECK		
Proposed Coverage Area (48.95%)		58.31
Clear Coverage Area (48.95%)		58.31
FAR CHECK		
Proposed Area of FAR		192.86
Clear Area of FAR		192.86
BUILD UP AREA CHECK		
Total Proposed Buildup Area		211.50
ARCHITECT SUPERVISOR (Sign)	OWNER	
DEVELOPMENT AUTHORITY		LOCAL BODY

COLOR INDEX	
Color Index:	
Plot Boundary	Green
Abutting Road	Red
Proposed Work (Coverage Area)	Blue
Existing (To be retained)	Yellow
Existing (To be demolished)	Black

Building Name	No. of Same Bldg	Total Built Up Area (Sq.mt)	Deductions (Area in Sq.mt)	Proposed FAR Area (Sq.mt)	Total FAR Area (Sq.mt)	Tent (No.)
AT (A1)	1	211.50	6.45	12.19	192.86	01
Grand Total	1	211.50	6.45	12.19	192.86	01

BRIEF SPECIFICATION

FOUNDATION :- R.C.C. (1:1.5:3) Column footing foundation.

PLINTH :- 12"th R.C.C. (1:1.5:3) all round on plinth level.

FLOORING :- 1.5"th Marble. flooring over 3"th P.C.C. (1:3:6).

SUPER STRUCTURE :- First class brick work in cement mortar (1:6).

SLAB,BEAM, stairs & LINTEL :- All R.C.C. work (1:1.5:3).

WOOD WORK :- All door & window frames of sal wood

PLASTERING :- 12mm cement plaster (1:6) both side.

SCHEDULE	
D1 - 1.07 x 2.13	W - 0.9 x 1.22
D2 - 0.9 x 2.13	W1 - 1.22 x 1.22
D3 - 0.76 x 2.13	W2 - 1.5 x 1.22
CG - 1.22 x 2.13	V - 0.61 x 0.61

SIG. OF OWNER

SIG. OF ENGINEER