

Project Title :SKYLINE INFRA

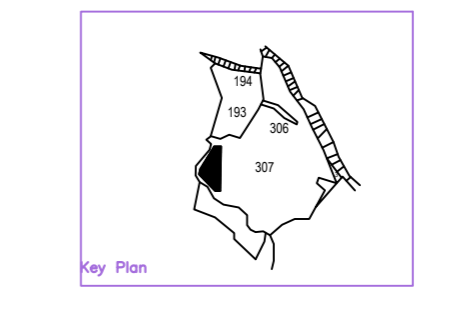
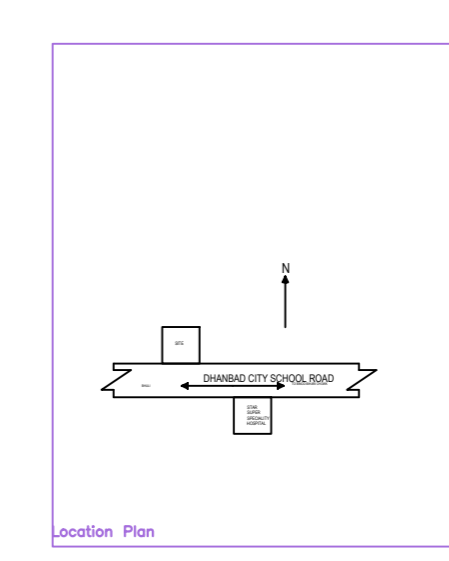
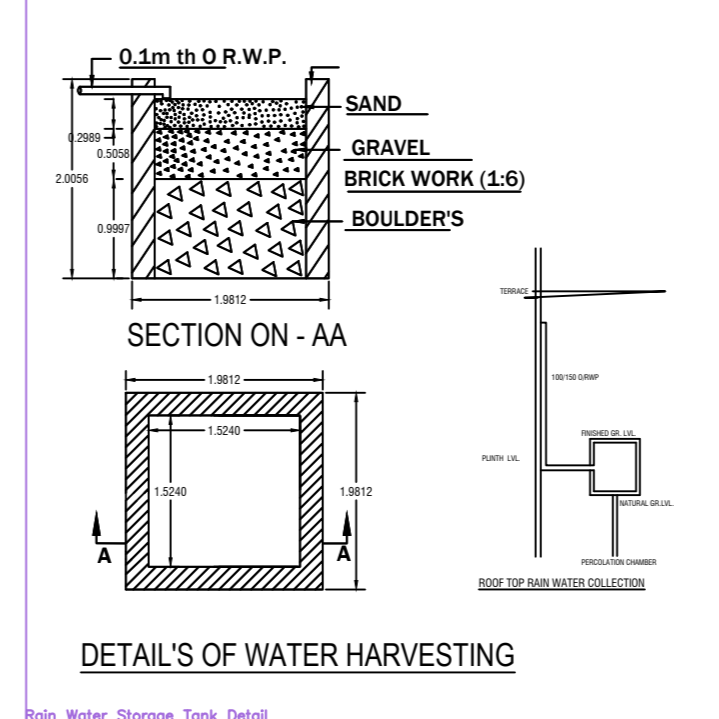
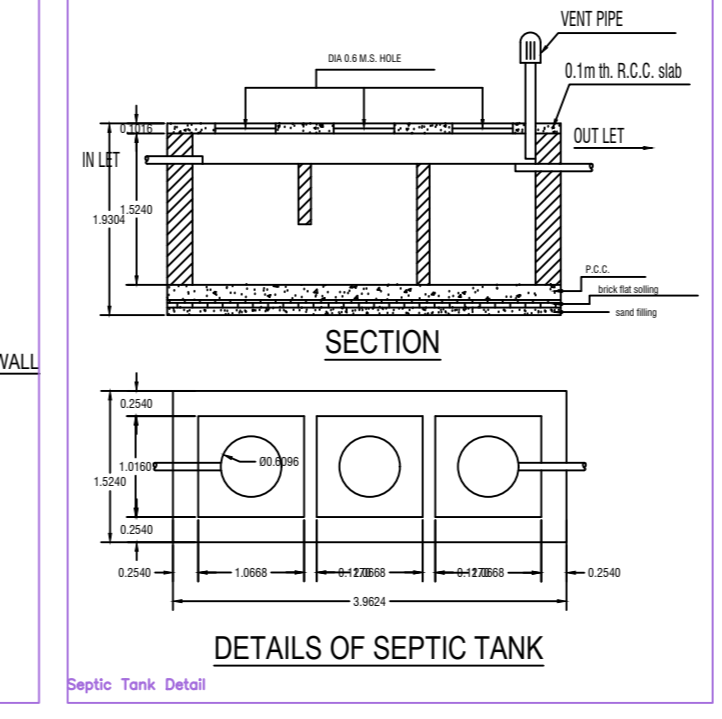
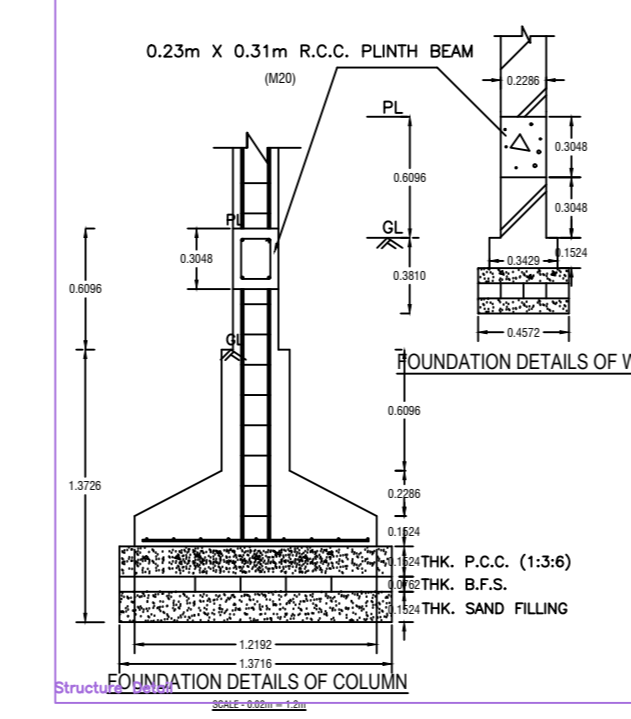

BRIEF SPECIFICATION

FOUNDATION - R.C.C. (1:1.5:3) Column footing foundation.
PLINTH - > 12"th R.C.C. (1:1.5:3) all round on plinth level.
FLOORING - > 1.5"th Marble flooring over 3"th P.C.C. (1:3:6).
SUPER STRUCTURE - First class brick work in cement mortar (1:4:8).
SLAB BEAM, stairs & LINTEL - All R.C.C. work (1:1.5:3).
WOOD WORK - All door & window frames of sal wood.
PLASTERING - 12mm cement plaster (1:4:8) both side.

SCHEDULE

D1 - 1.07 x 2.13	W - 0.9 x 1.22
D2 - 0.9 x 2.13	W1 - 1.22 x 1.22
D3 - 0.76 x 2.13	W2 - 1.5 x 1.22
CG - 1.22 x 2.13	V - 0.61 x 0.61

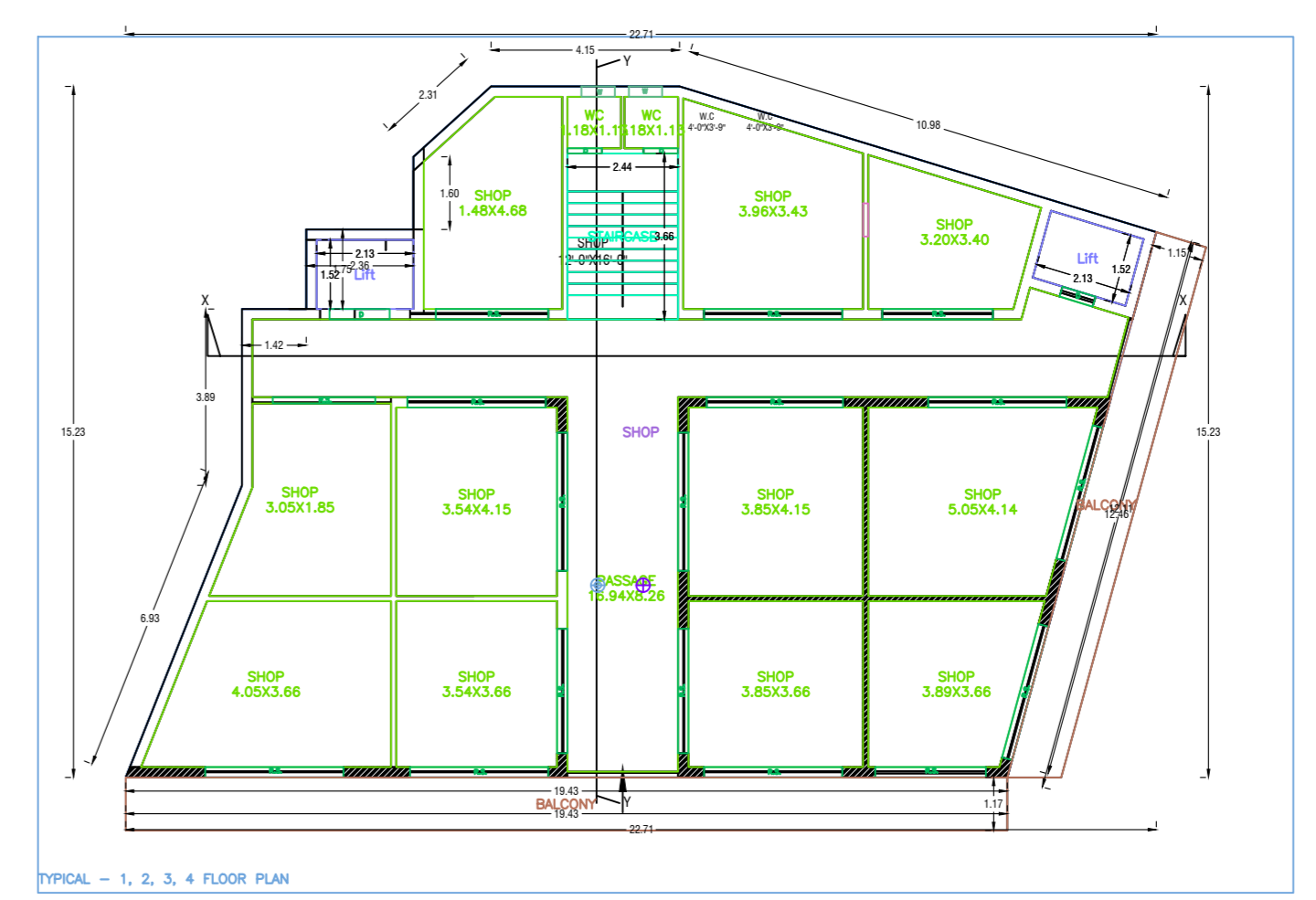
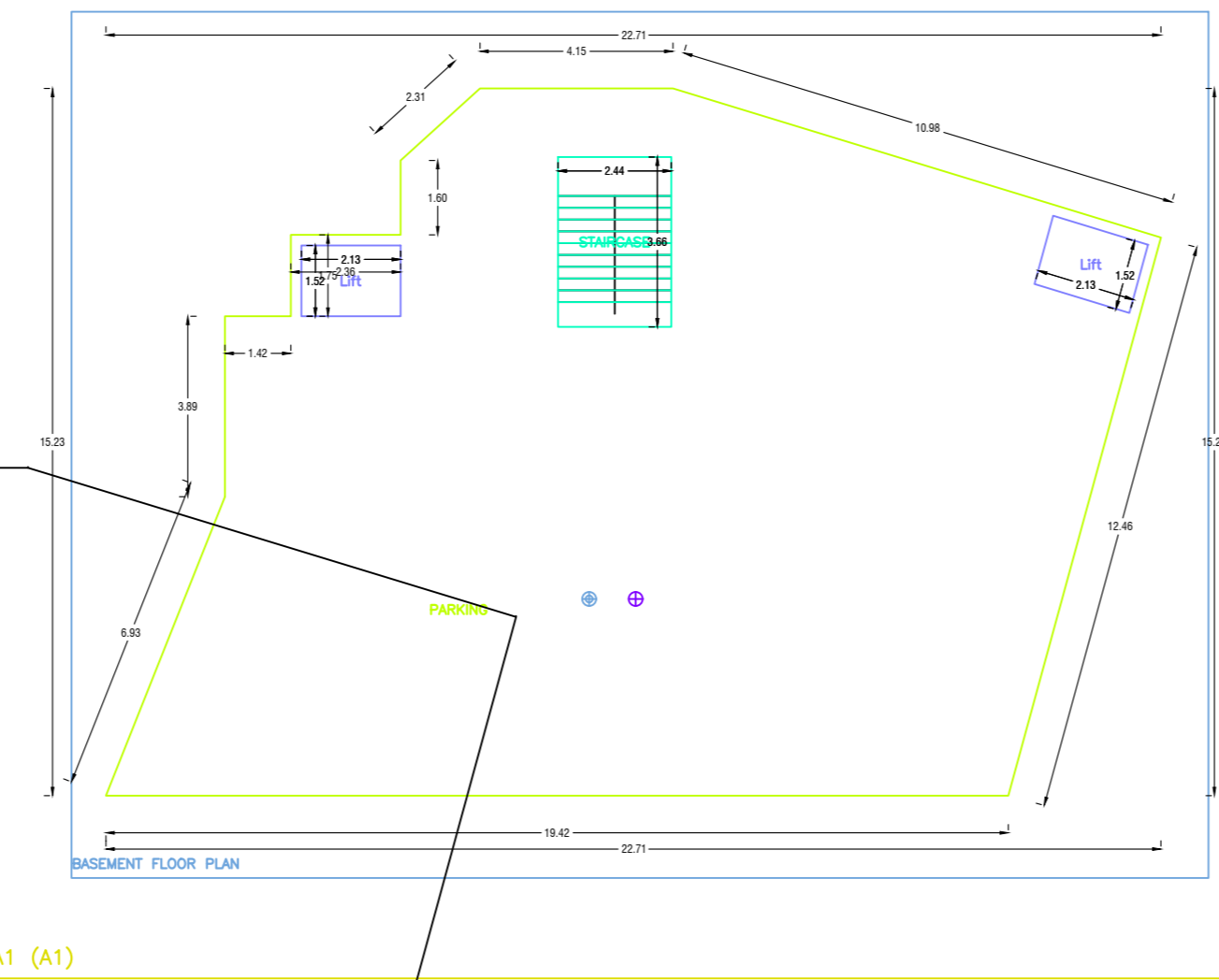
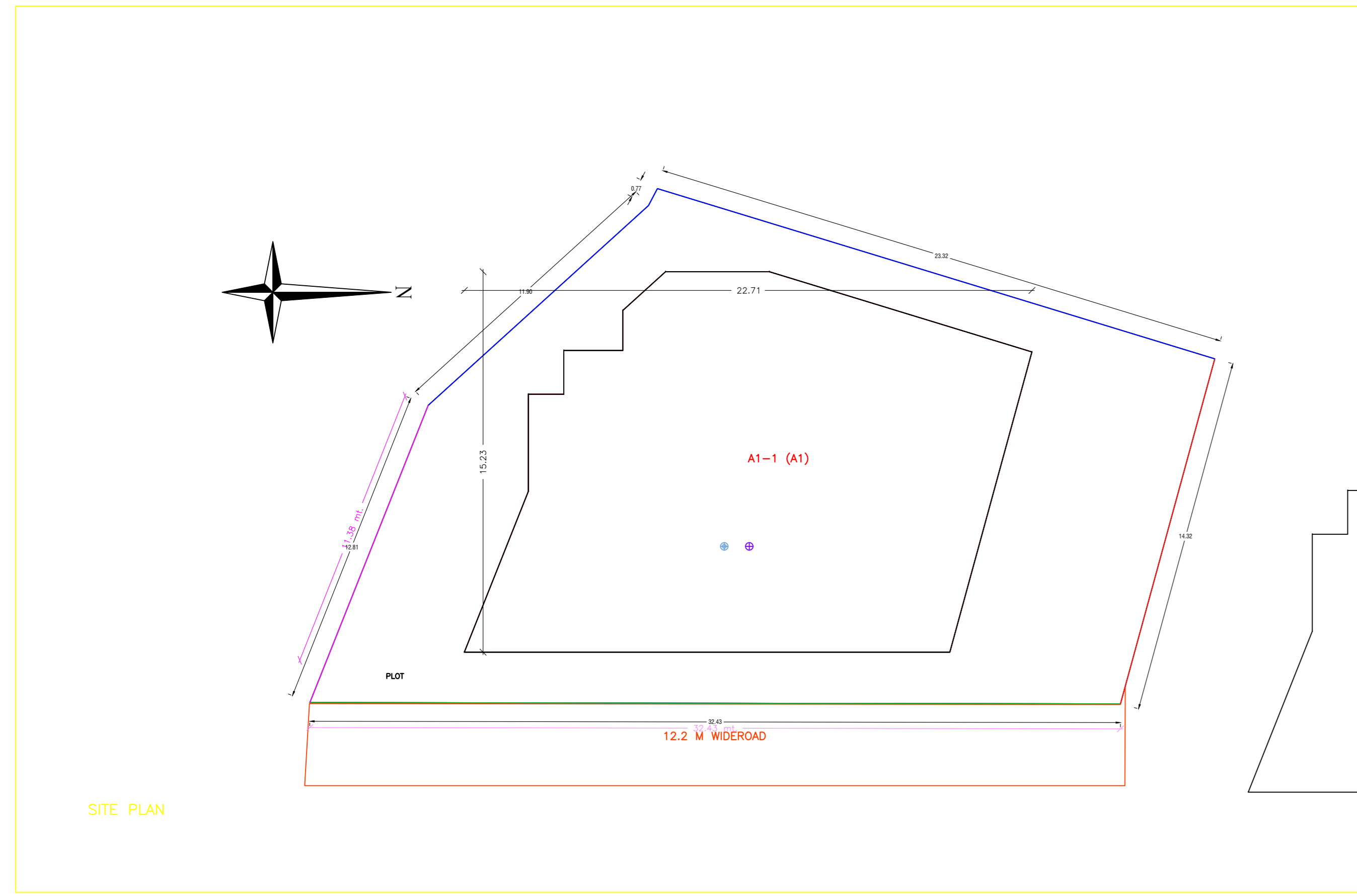
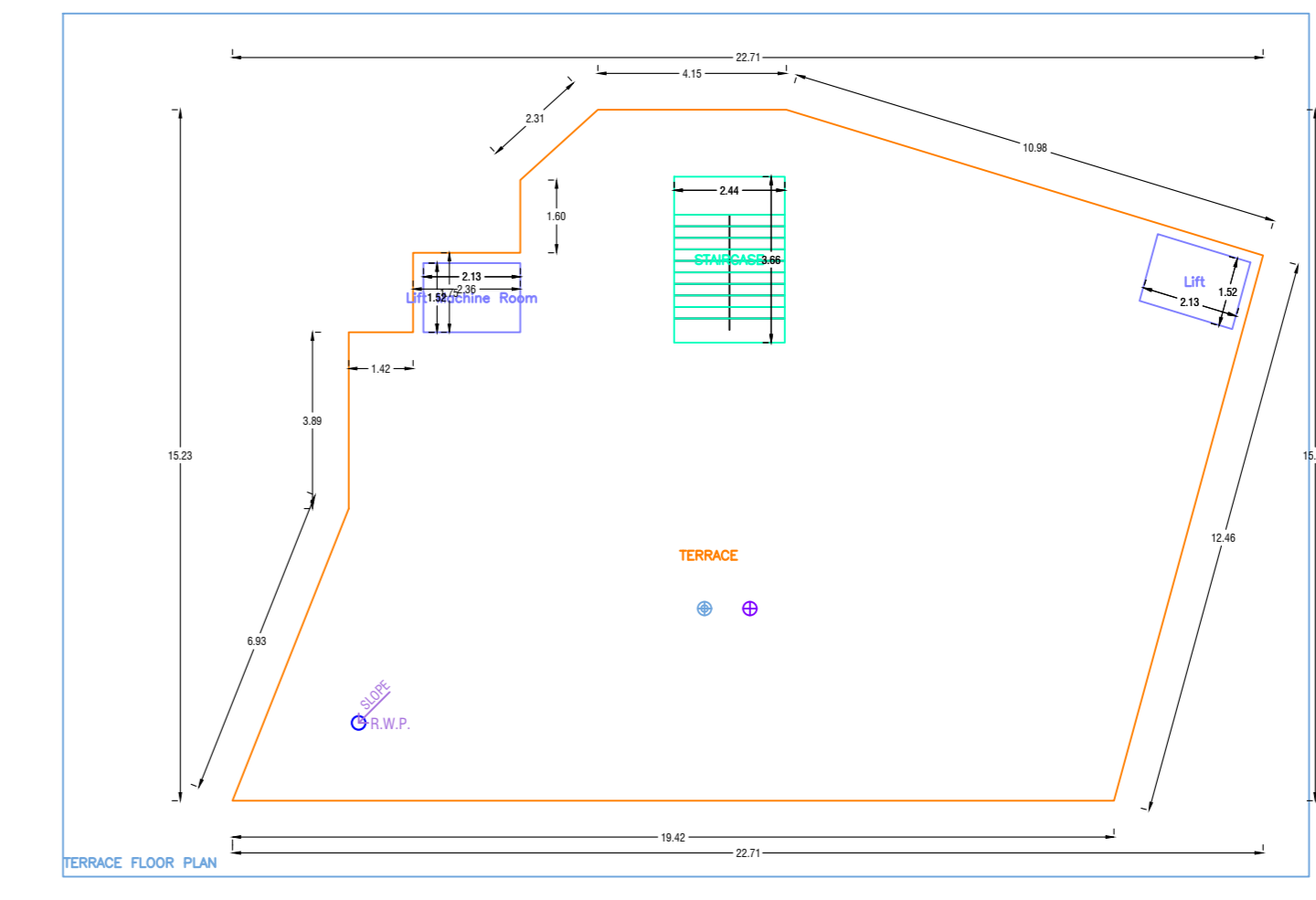
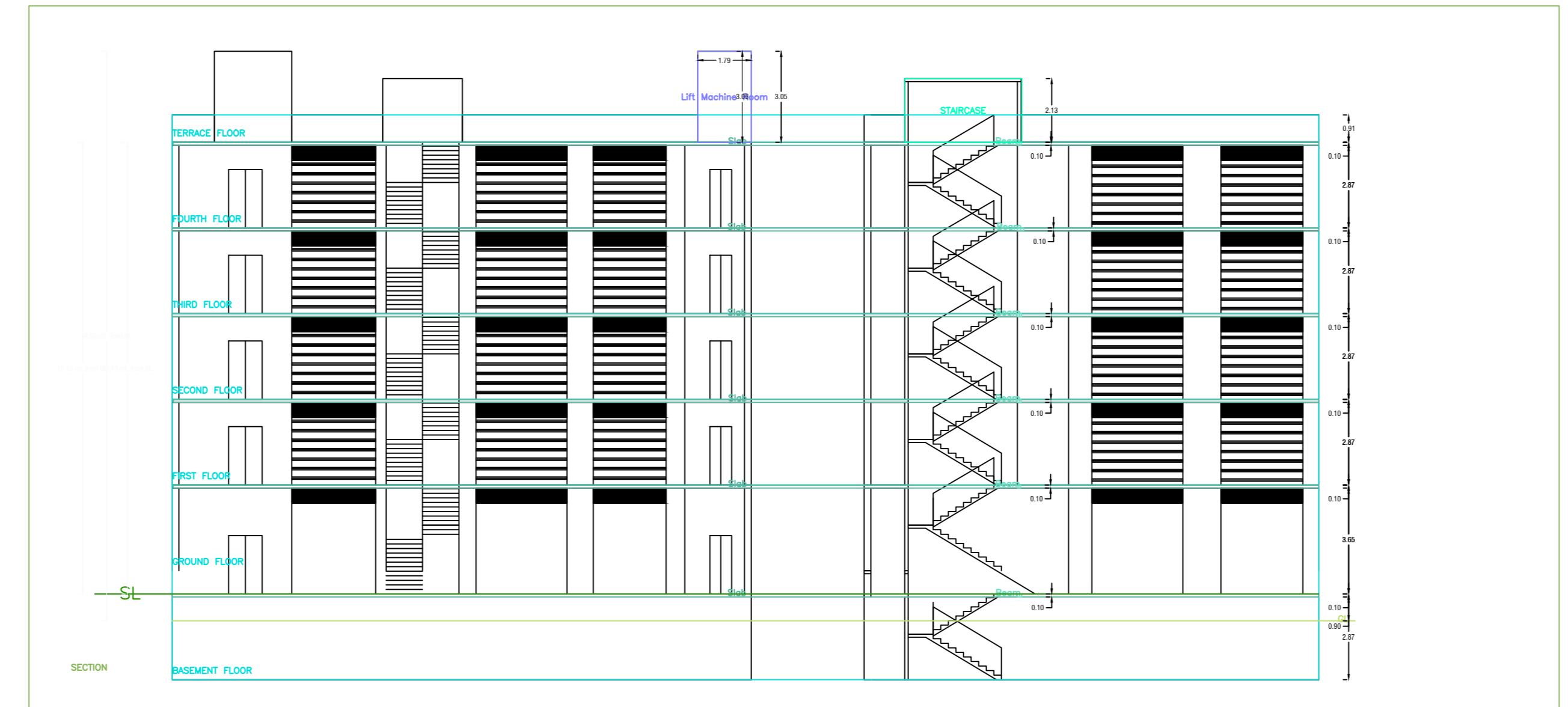
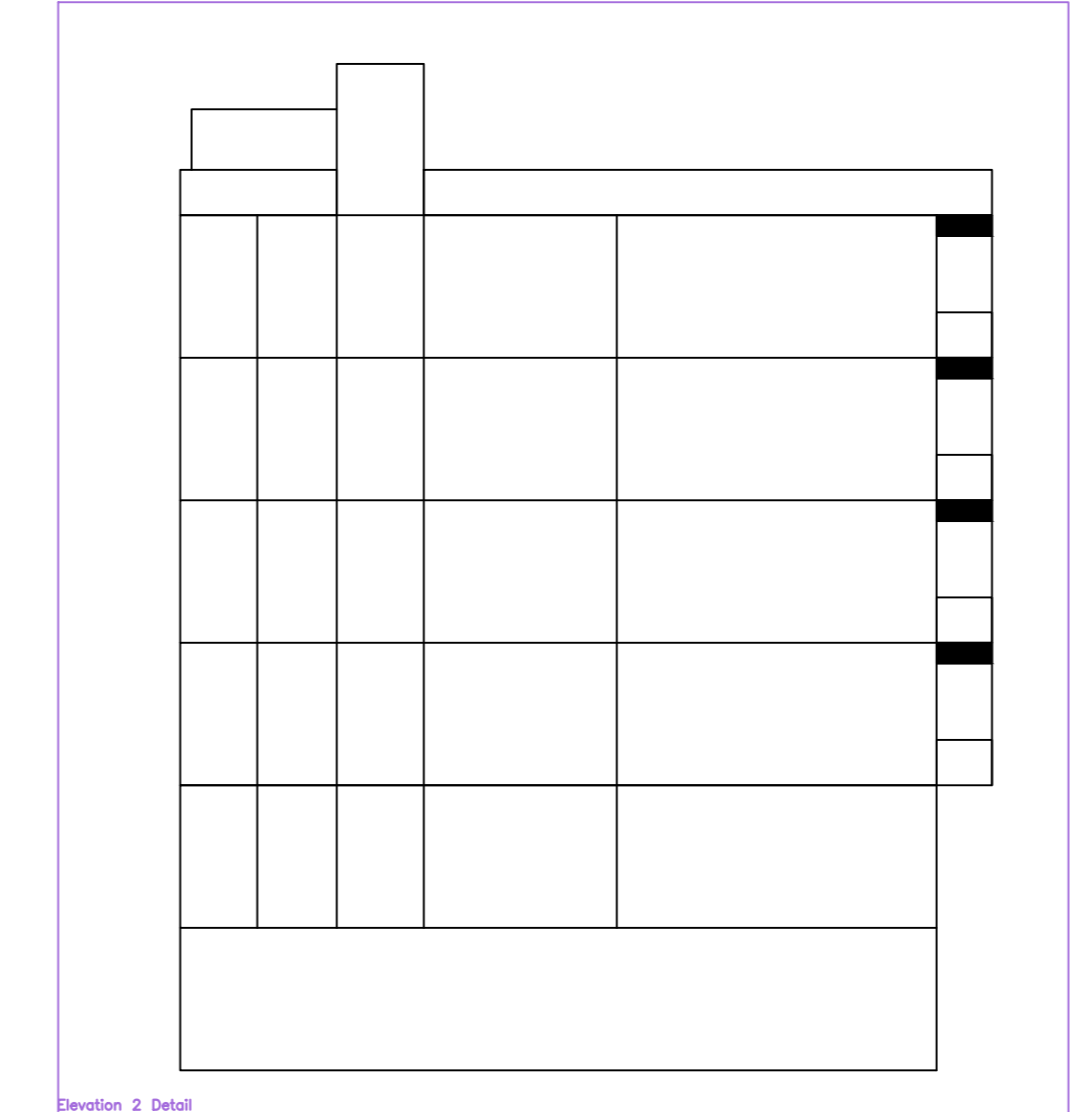
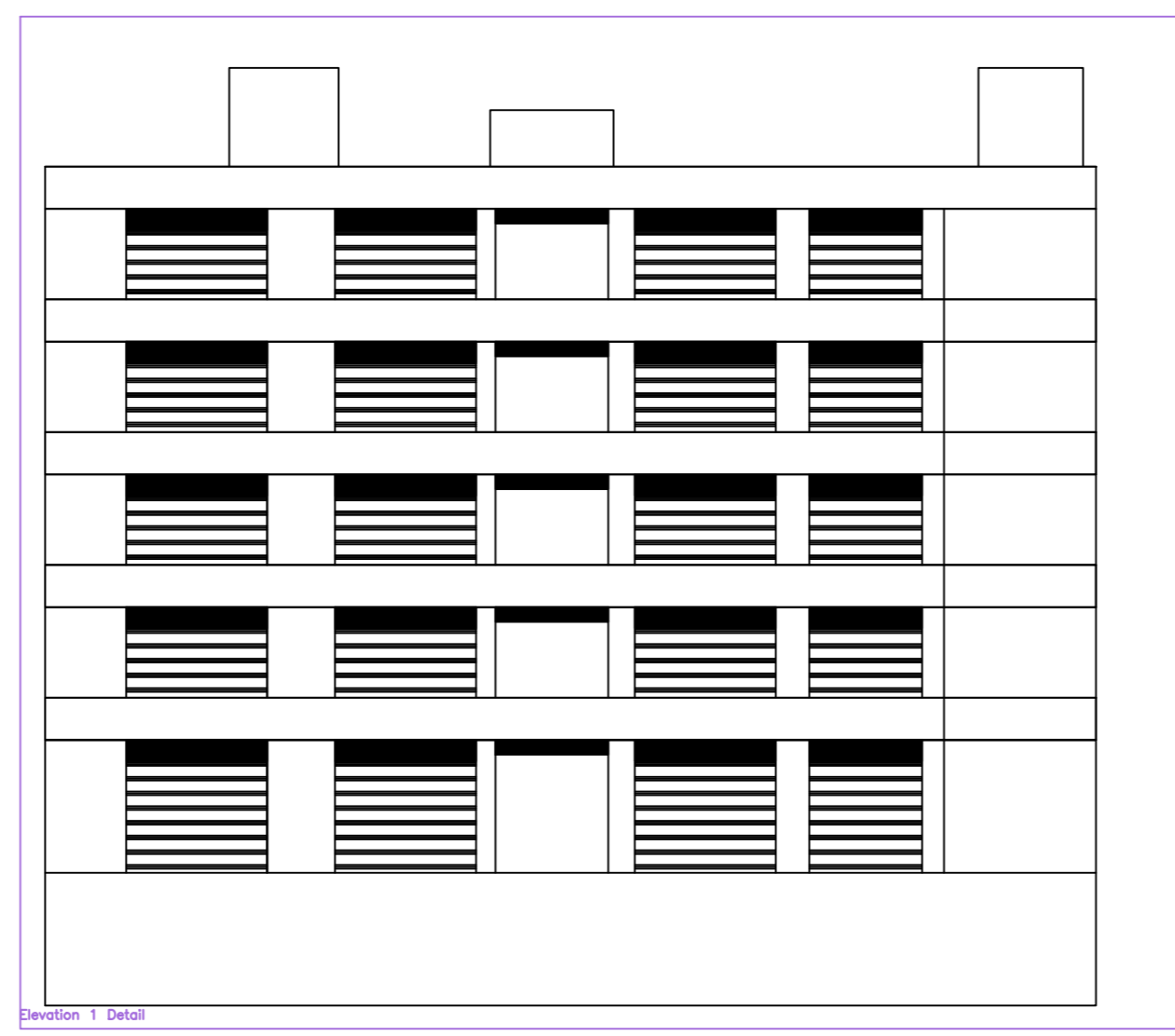

Building A1 (A1)

Floor Name	Floor Slab Area (Sq.M)	Column Area (Sq.M)	Proposed Area (Sq.M)	Net Area (Sq.M)	Floor Area (Sq.M)
Basement	262.77	6.50	0.00	247.34	0.00
Ground	256.27	6.50	0.00	262.77	0.00
First	256.27	6.50	0.00	256.27	0.00
Second	256.27	6.50	0.00	256.27	0.00
Third	256.27	6.50	0.00	256.27	0.00
Total	1027.85	26.00	0.00	1001.85	0.00

SCHEDULE OF JOINERY

ITEM NO.	DESCRIPTION	UNIT	QTY	REMARKS
1	WOODEN DOOR	SQ.M	10	
2	WOODEN WINDOW	SQ.M	20	

SCHEDULE OF JOINERY

ITEM NO.	DESCRIPTION	UNIT	QTY	REMARKS
1	WOODEN DOOR	SQ.M	10	
2	WOODEN WINDOW	SQ.M	20	

Barony Calculations Table

FLOOR	Area	Volume	Weight
FLOOR	1000.00	1000.00	1000.00
WALL	1000.00	1000.00	1000.00
ROOF	1000.00	1000.00	1000.00

PROJECT INFORMATION

Project Name	SKYLINE INFRA
Client Name	SKYLINE INFRA
Project Location	SKYLINE INFRA
Project Type	SKYLINE INFRA
Project Status	SKYLINE INFRA
Project Date	SKYLINE INFRA
Project Engineer	SKYLINE INFRA
Project Manager	SKYLINE INFRA
Project Supervisor	SKYLINE INFRA
Project Designer	SKYLINE INFRA
Project Checker	SKYLINE INFRA
Project Approver	SKYLINE INFRA

COLOR INDEX

Color	Material
Red	Concrete
Green	Brickwork
Blue	Plaster
Yellow	Marble

PERFORMANCE CALCULATION

Item	Unit	Quantity	Rate	Amount
Concrete	Cu.M	1000	1000	1000000
Brickwork	Sq.M	2000	2000	4000000
Plaster	Sq.M	3000	3000	9000000
Marble	Sq.M	1000	1000	10000000

MARKING DETAIL

Marking	Scale	Foot Mark	Plot Mark	Site Mark	Grid Mark
D1	1:100	100	100	100	100
D2	1:100	100	100	100	100
D3	1:100	100	100	100	100
CG	1:100	100	100	100	100

AREA & PERIMETER DETAIL

Area	Perimeter
1000.00	1000.00
2000.00	2000.00
3000.00	3000.00
4000.00	4000.00

BAR BONDING DETAIL

Bar No.	Bar Size	Bar Length	Bar Weight
1	12mm	1000	1000
2	12mm	2000	2000
3	12mm	3000	3000
4	12mm	4000	4000