

SITE PLAN

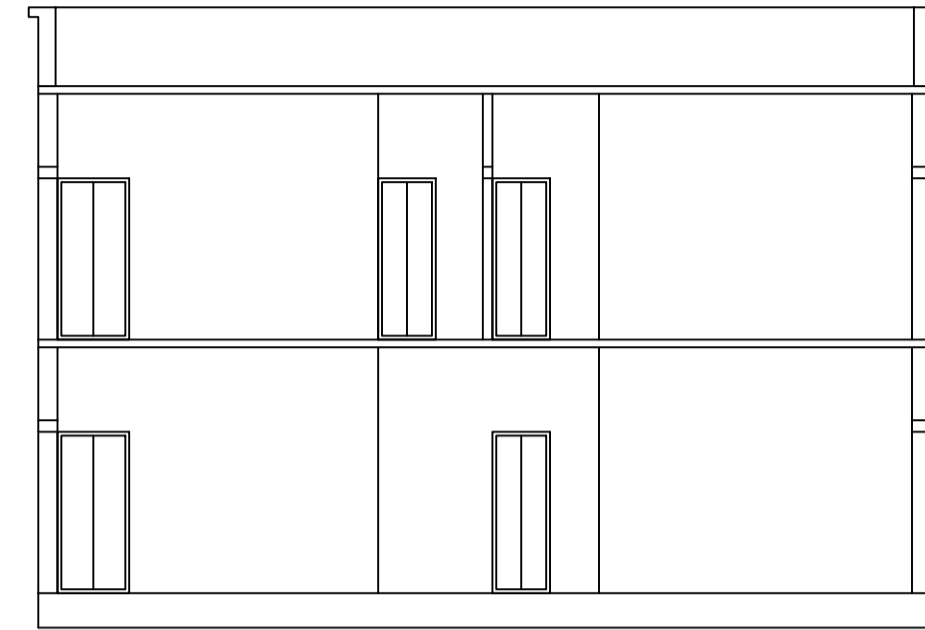

SECTION ON X-X

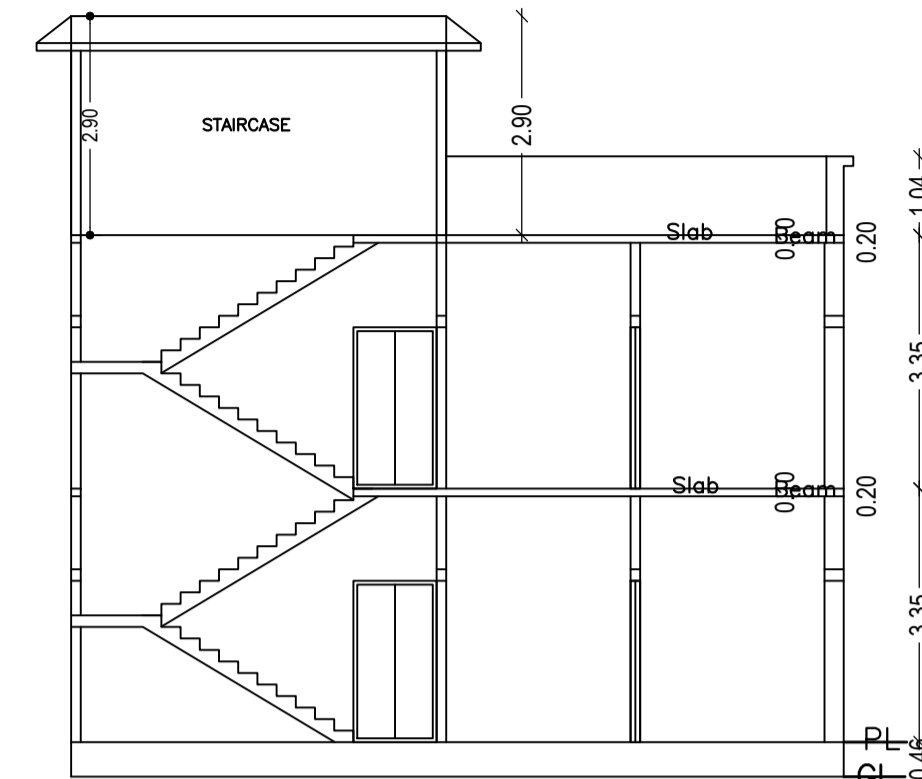

SECTION ON Y-Y

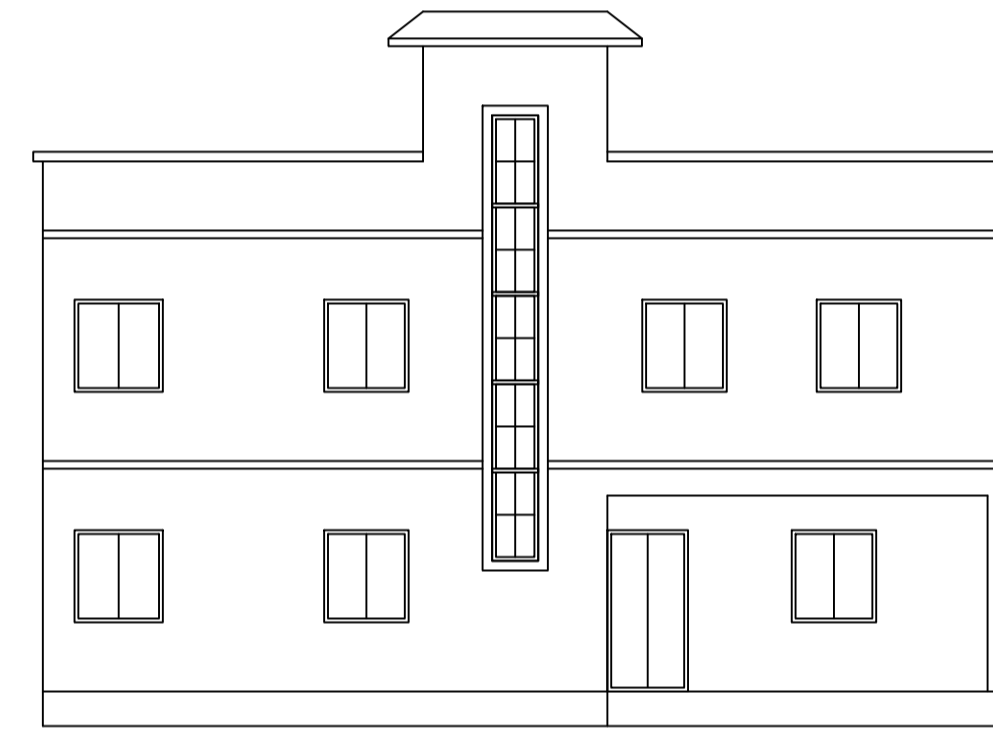

FRONT ELEVATION

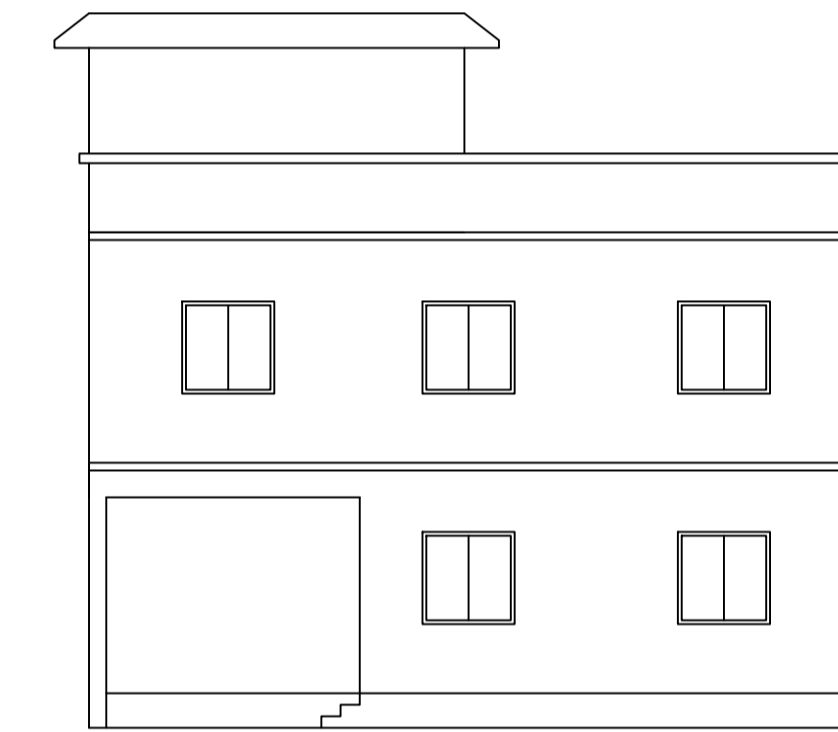

LEFT SIDE ELEVATION

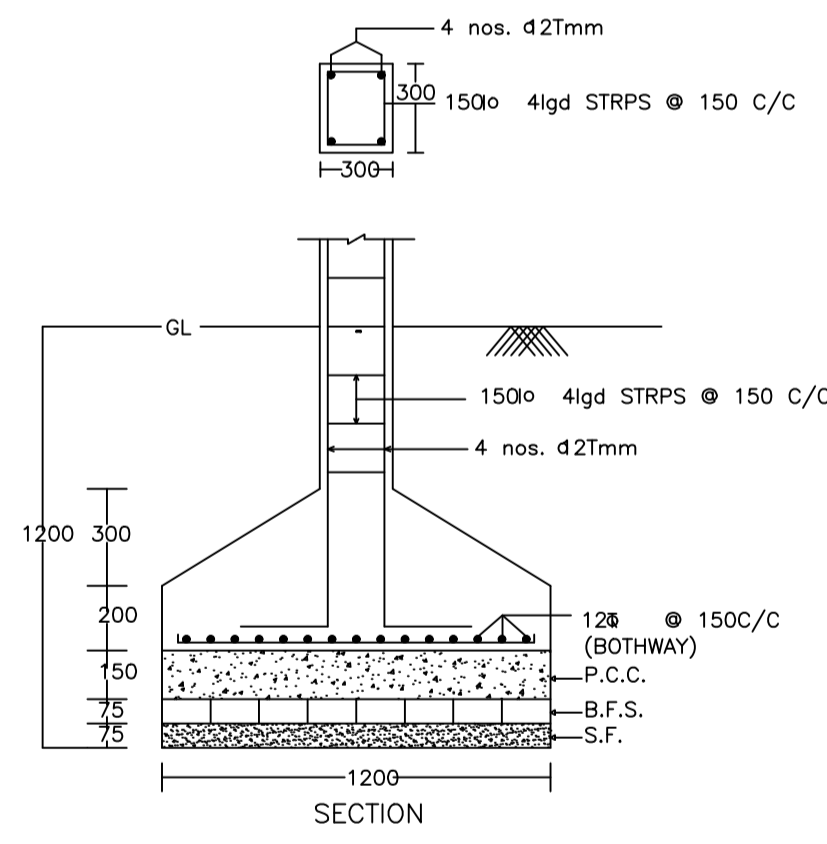

SECTION

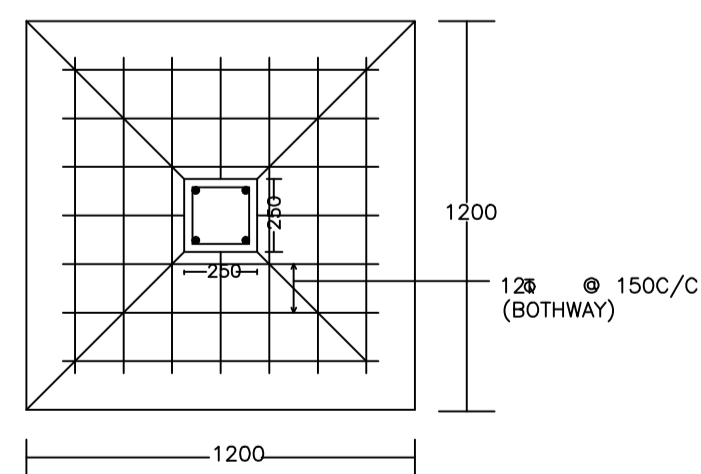

DETAIL OF COLUMNS

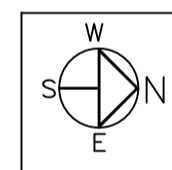

KEY PLAN

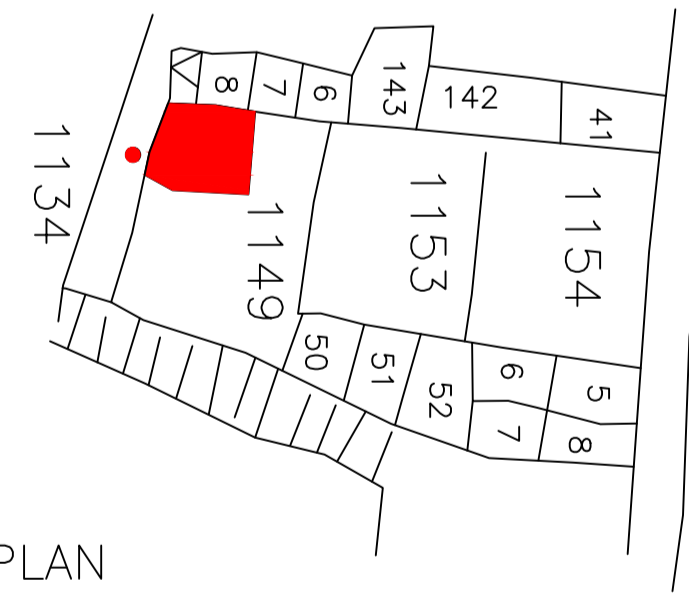

LOCATION PLAN

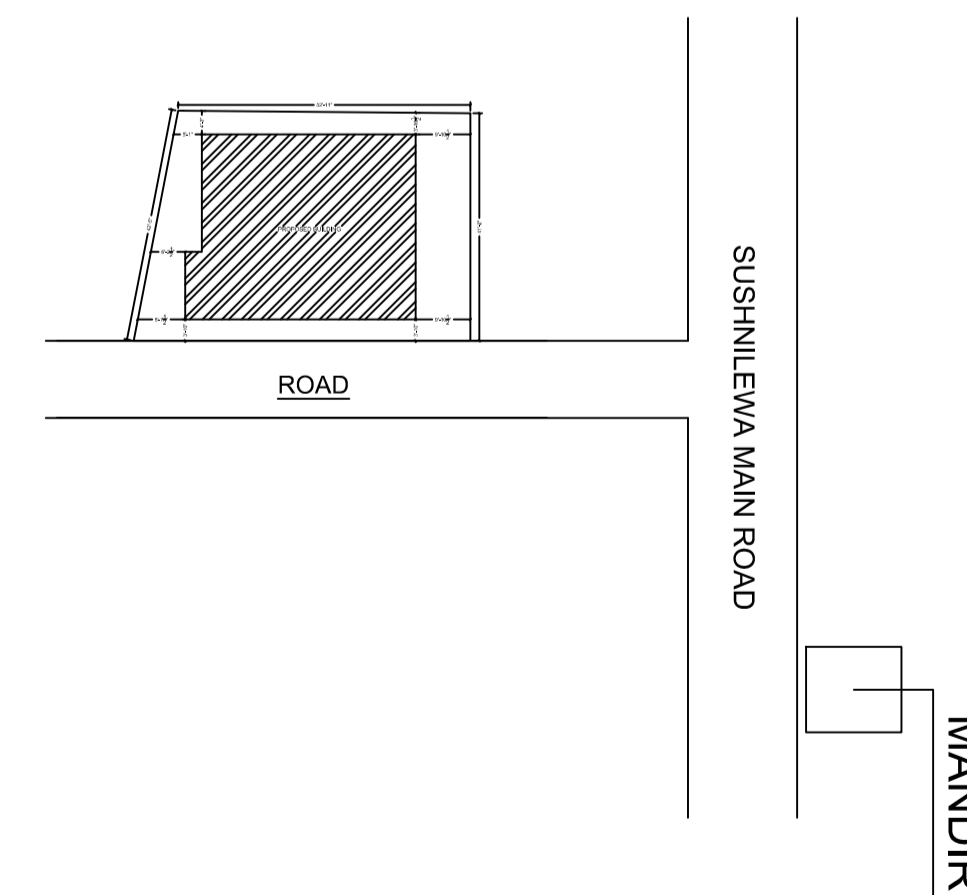

ROAD

UnitBUA Table for Building :A (RESIDENCE)

FLOOR	Name	UnitBUA Type	UnitBUA Area	Carpet Area	No. of Rooms	No. of Tenement
GROUND FLOOR PLAN	SPLIT A	FLAT	185.67	185.15	8	1
FIRST FLOOR PLAN	SPLIT A	FLAT	0.00	0.00	10	0
Total:	-	-	185.67	185.15	18	1

SCHEDULE OF DOOR:

BUILDING NAME	NAME	LENGTH	HEIGHT	NOS
A (RESIDENCE)	D2	0.76	2.10	04
A (RESIDENCE)	D1	0.91	2.10	03
A (RESIDENCE)	D1	0.94	2.10	01
A (RESIDENCE)	D	1.07	2.10	10
A (RESIDENCE)	D	1.09	2.10	01

SCHEDULE OF WINDOW/VENTILATION:

BUILDING NAME	NAME	LENGTH	HEIGHT	NOS
A (RESIDENCE)	V	0.61	1.22	04
A (RESIDENCE)	W	0.79	1.22	01
A (RESIDENCE)	W	1.22	1.22	17
A (RESIDENCE)	W	2.30	1.22	02
A (RESIDENCE)	W	2.75	1.22	02

Building :A (RESIDENCE)

Floor Name	Total Built Up Area (Sq.mt.)	Deductions (Area in Sq.mt.) Parking	Proposed FAR Area (Sq.mt.) Resi.	Total FAR Area (Sq.mt.)	Total Consumed Additional FAR Area (Sq.mt.)	Trmt (No.)
Ground Floor	122.83	18.60	104.23	104.23	104.23	01
First Floor	122.82	0.00	122.82	122.82	122.82	00
Terrace Floor	0.00	0.00	0.00	0.00	0.00	00
Total :	245.65	18.60	227.05	227.05	227.05	01
Total Number of Same Buildings :	1					
Total :	245.65	18.60	227.05	227.05	227.05	01

Proposal Basic Information	
Proposal File No.	DMC/BI/0076/W22/2024
Owner Name	SRI. VIJAY KUMAR MANDAL
Khata No	33 (NEW 94)
Plot No	1070 (NEW 1149)
Village Name	Susnilewa
Use	Residential
SubUse	Bungalow/ Dwelling / Non Apartment

AREA STATEMENT		VERSION NO. : 1.0.68
DHANBAD MUNICIPAL CORPORATION		VERSION DATE: 16/10/2020
PROJECT DETAIL:		
Region: JHARKHAND URBAN LOCAL BODIES	Plot Use: Residential	
District: DHANBAD	Plot SubUse: Bungalow/ Dwelling / Non Apartment	
Authority: DHANBAD MUNICIPAL CORPORATION	PlotNearby/ReligiousStructure: NA	
Inward No: DMC/BI/0076/W22/2024	Plot/SubPlot No: 1070 (NEW 1149)	
Application Type: General Proposal	North: Plot No. - SEEMA DEVI	
Project Type: Building Permission	South: Plot No. - NEW PLOT NO. - 1134	
Nature of Development: New	East: Road Width - 3.66	
Location of Development Area: Old Area	West: Plot No. - NEW PLOT NO. - 1184	
AREA DETAILS:		
AREA OF PLOT (Minimum)	(A)	SQ.MT. 217.58
NET AREA OF PLOT(Gross Plot Area - Deduction from Gross Plot area)	(A-Deductions)	217.58
Deduction for Balance Plot Area(from Gross Plot Area)		
Common Plot		13.29
Total		13.29
BALANCE AREA OF PLOT(Net Plot Area - Recreational/Amenity space)	(A-Deductions)	204.29
PLOT AREA FOR COVERAGE(Net Plot Area)	(A-Deductions)	217.58
Plot Area for FAR (Net Plot Area + Road/Widening Area)	(A-Deductions)	217.58
COVERAGE CHECK		
Permissible Coverage area (70.00 %)		152.31
Proposed Coverage Area (56.45 %)		122.82
Total Prop. Coverage Area (56.45 %)		122.82
Balance coverage area (13.55 %)		29.49
FAR CHECK		
Perm. FAR Area (1.500)		326.37
Total Perm. FAR area		326.37
Residential FAR		227.05
Proposed FAR Area		227.05
Total Proposed FAR Area		227.05
Consumed FAR (Factor)		1.04
Balance FAR Area		99.32
BUILT UP AREA CHECK		
Total Proposed BuiltUp Area		245.65
ARCHITECT (Regd)		PARTHA PAL
ENGINEER (Regd)		
SUPERVISOR (Regd)		
OWNER (Regd)		SRI. VIJAY KUMAR MANDAL
DEVELOPMENT AUTHORITY		LOCAL BODY

COLOR INDEX	
PLOT BOUNDARY	Black
ABUTTING ROAD	Green
PROPOSED CONSTRUCTION	Red
COMMON PLOT	Yellow
ROAD WIDENING AREA	Orange
EXISTING (To be retained)	Blue
EXISTING (To be demolished)	White

Buildingwise Floor FAR Details

Floor Name	Building Name A (RESIDENCE)		Total	
	Proposed Built Up Area (Sq.mt.)	Proposed FAR Area (Sq.mt.)	Total Proposed Built Up Area (Sq.mt.)	Total FAR Area (Sq.mt.)
Ground Floor	122.83	104.23	122.83	104.23
First Floor	122.82	122.82	122.82	122.82
Terrace Floor	0.00	0.00	0.00	0.00
Total :	245.65	227.05	245.65	227.05

Building USE/SUBUSE Details

Building Name	Building Use	Building SubUse	Building Structure
A (RESIDENCE)	Residential	Bungalow/ Dwelling / Non Apartment	Non-Highrise

FAR & Tenement Details (Table 4c-1)

Building	No. of Same Bldg	Total Built Up Area (Sq.mt.)	Deductions (Area in Sq.mt.) Parking	Proposed FAR Area (Sq.mt.) Resi.	Total FAR Area (Sq.mt.)	Total Consumed Additional FAR Area (Sq.mt.)	Trmt (No.)
A (RESIDENCE)	1	245.65	18.60	227.05	227.05	227.05	01
Grand Total :	1	245.65	18.60	227.05	227.05	227.05	01

LTP NAME AND SIGNATURE	STRUCTURAL ENG'S NAME AND SIGNATURE	BUILDER NAME AND SIGNATURE	DIGITAL SIGNATURE
PARTHA PAL DMC/ENG/0021/2016			

Proposal Basic Information	
Proposal File No.	DMC/BP/0076/W22/2024
Owner Name	SRI. VIJAY KUMAR MANDAL
Khata No	33 (NEW 94)
Plot No	1070 (NEW 1149)
Village Name	Susnilewa
Use	Residential
SubUse	Bungalow/ Dwelling / Non Apartment

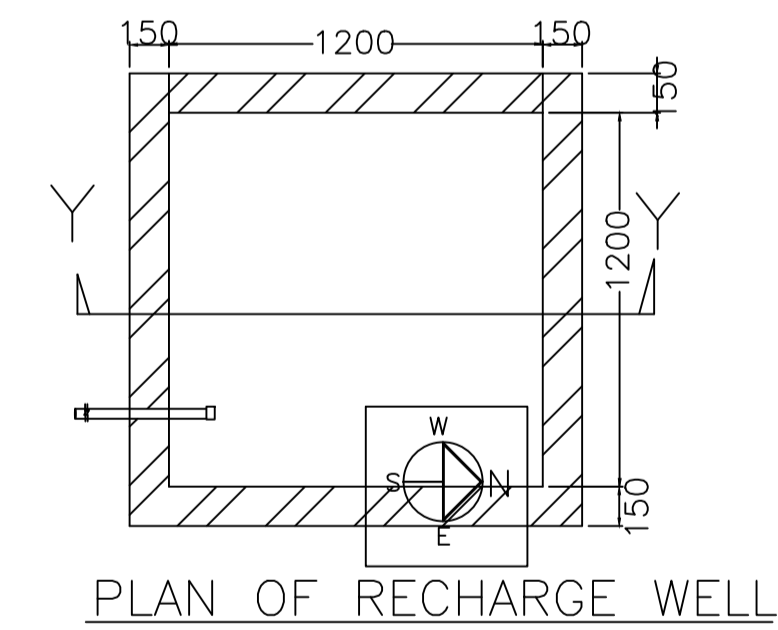
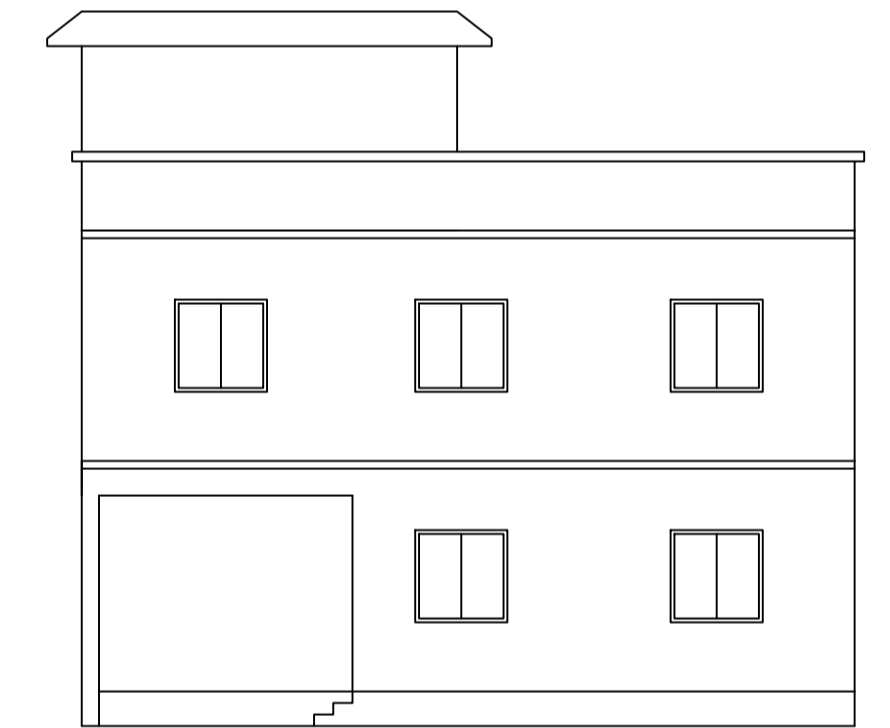
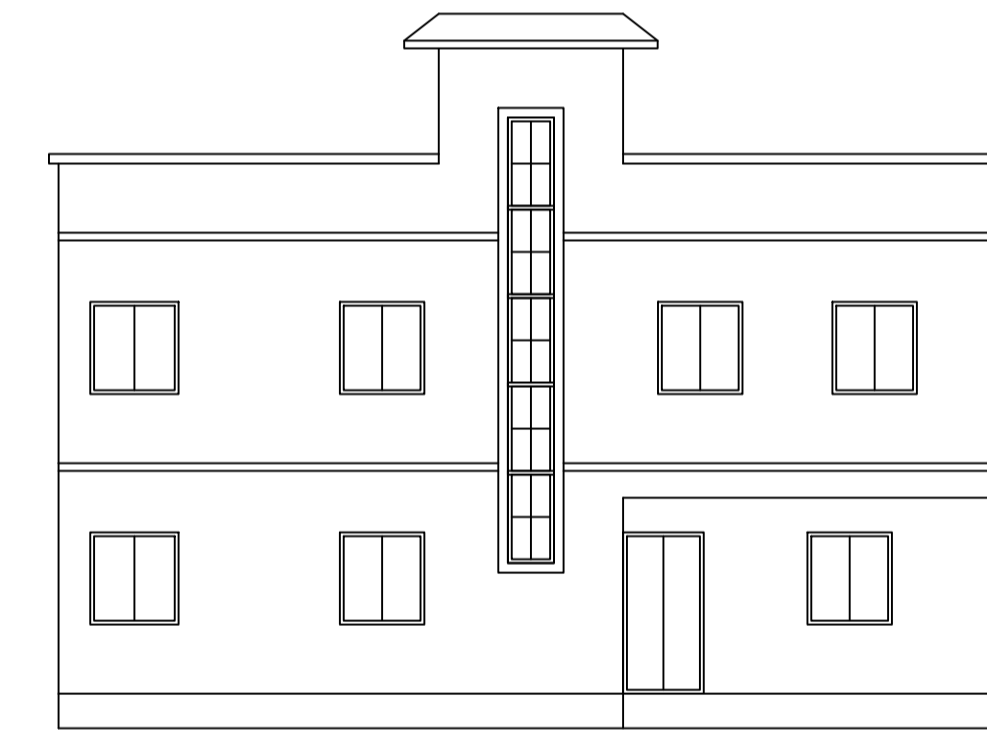
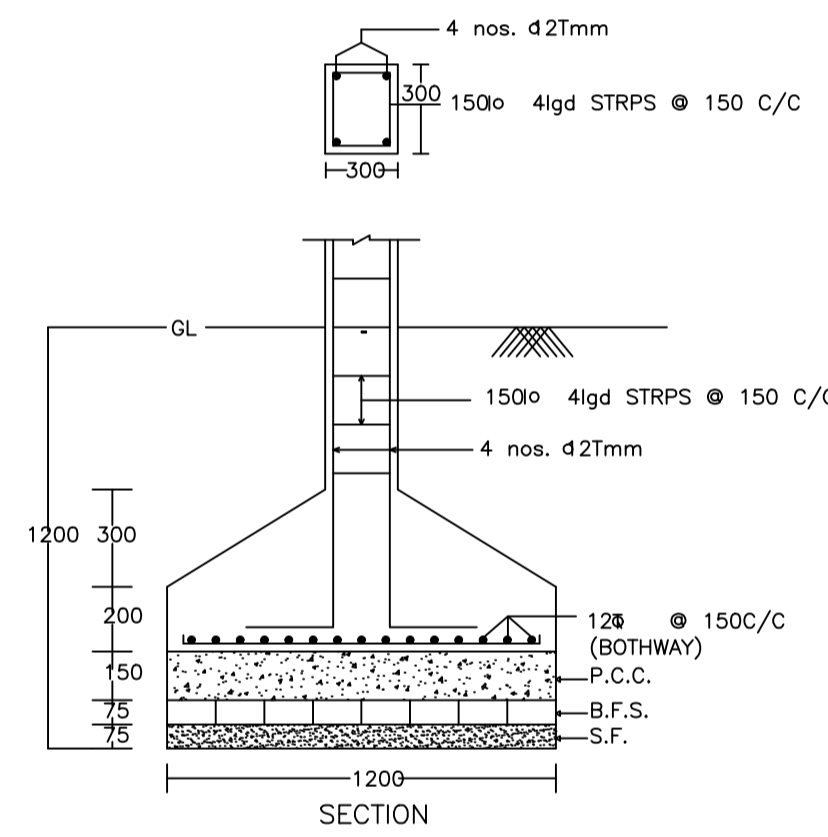
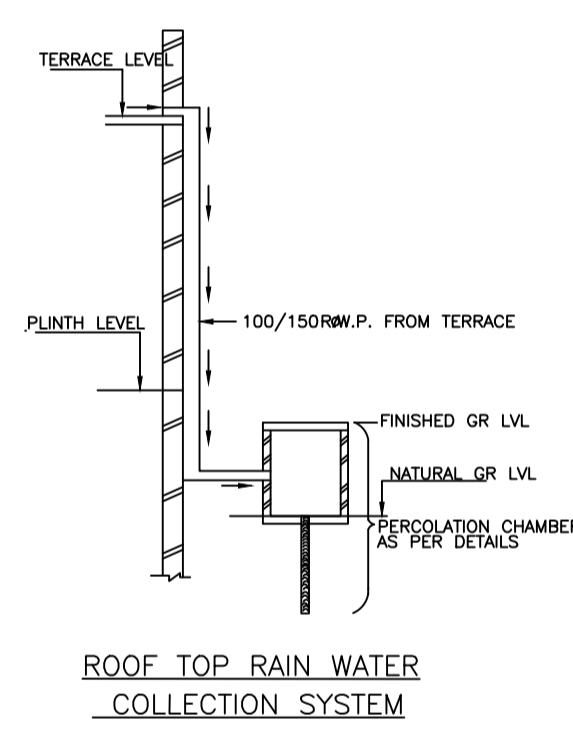
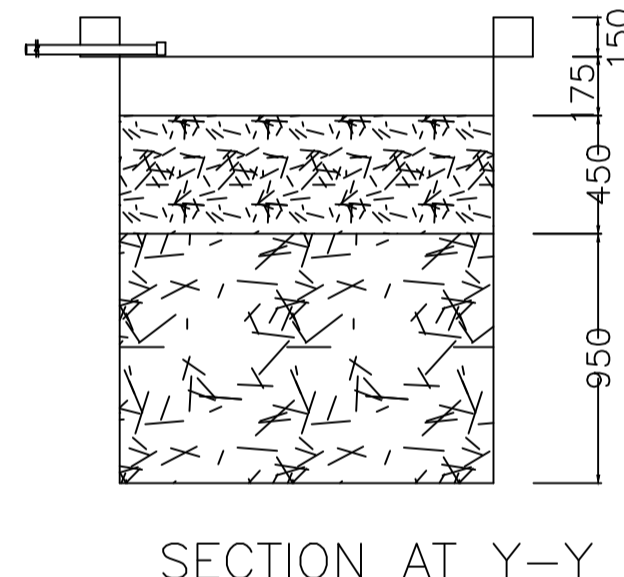
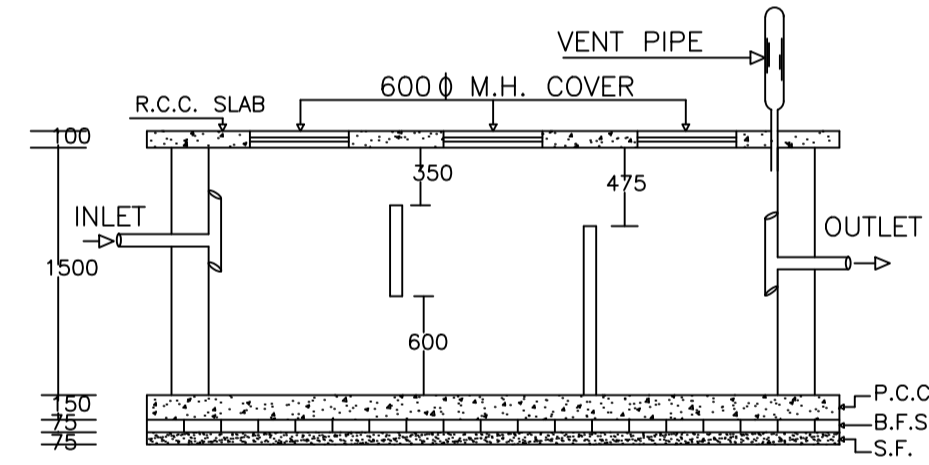
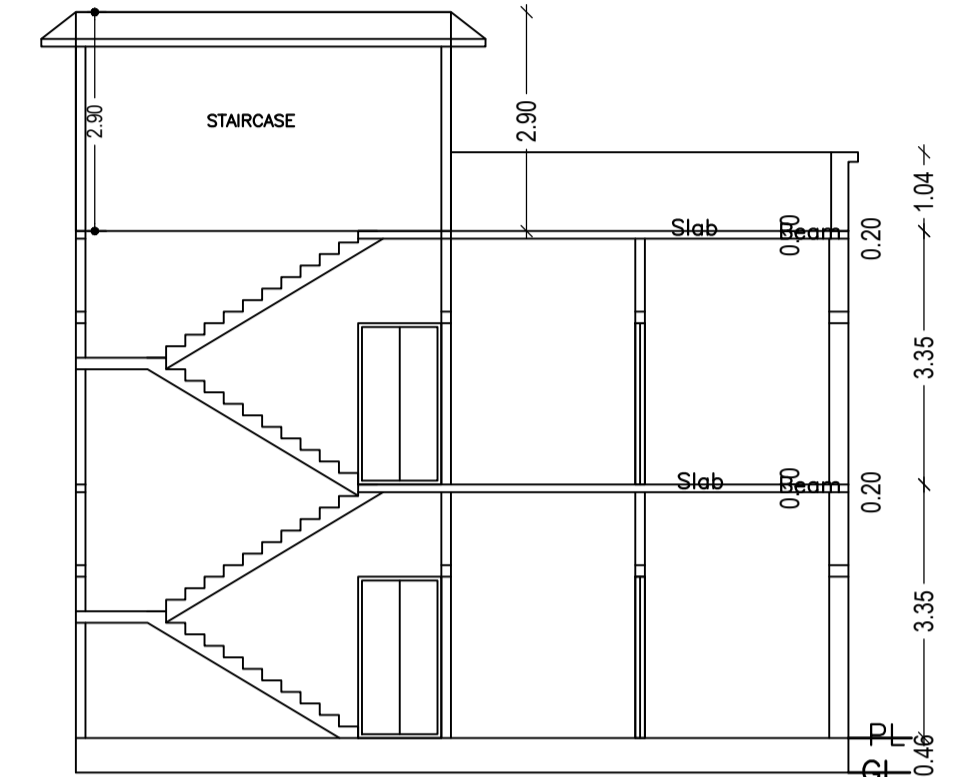
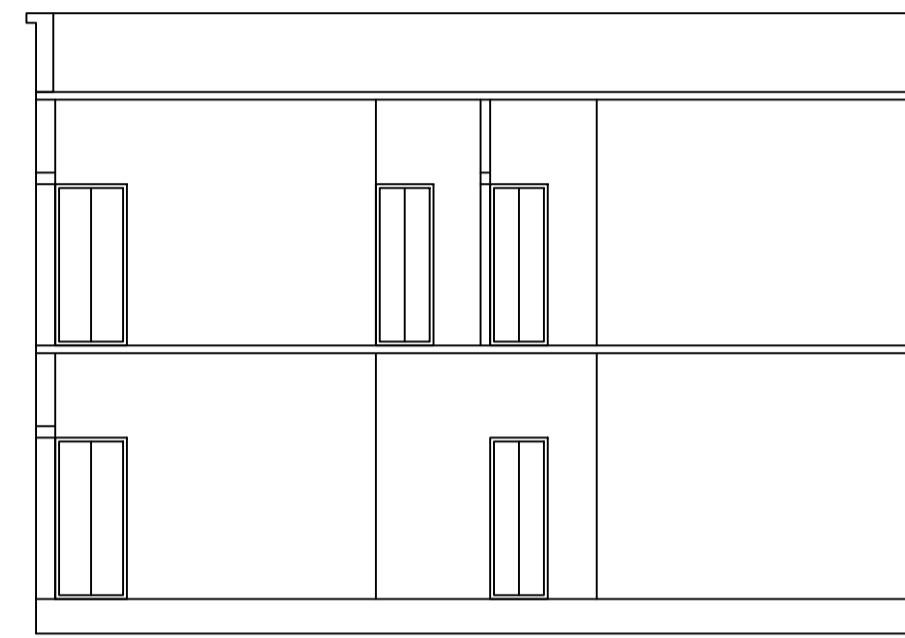
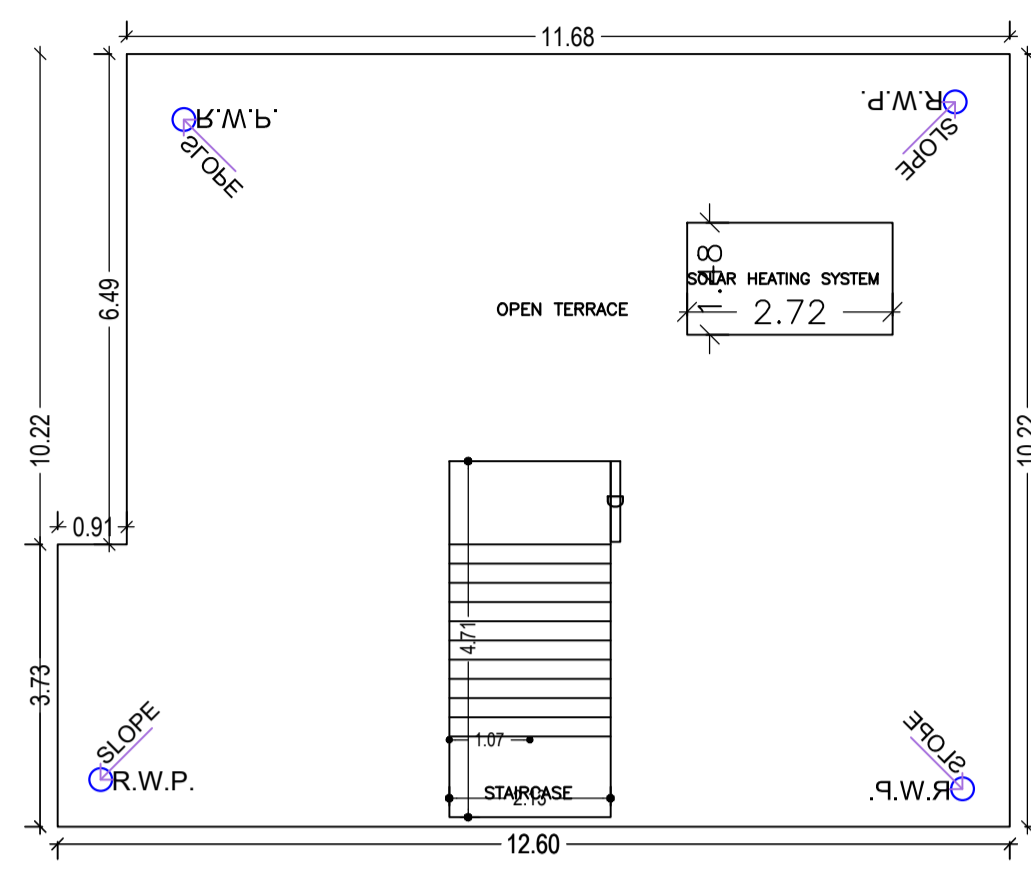
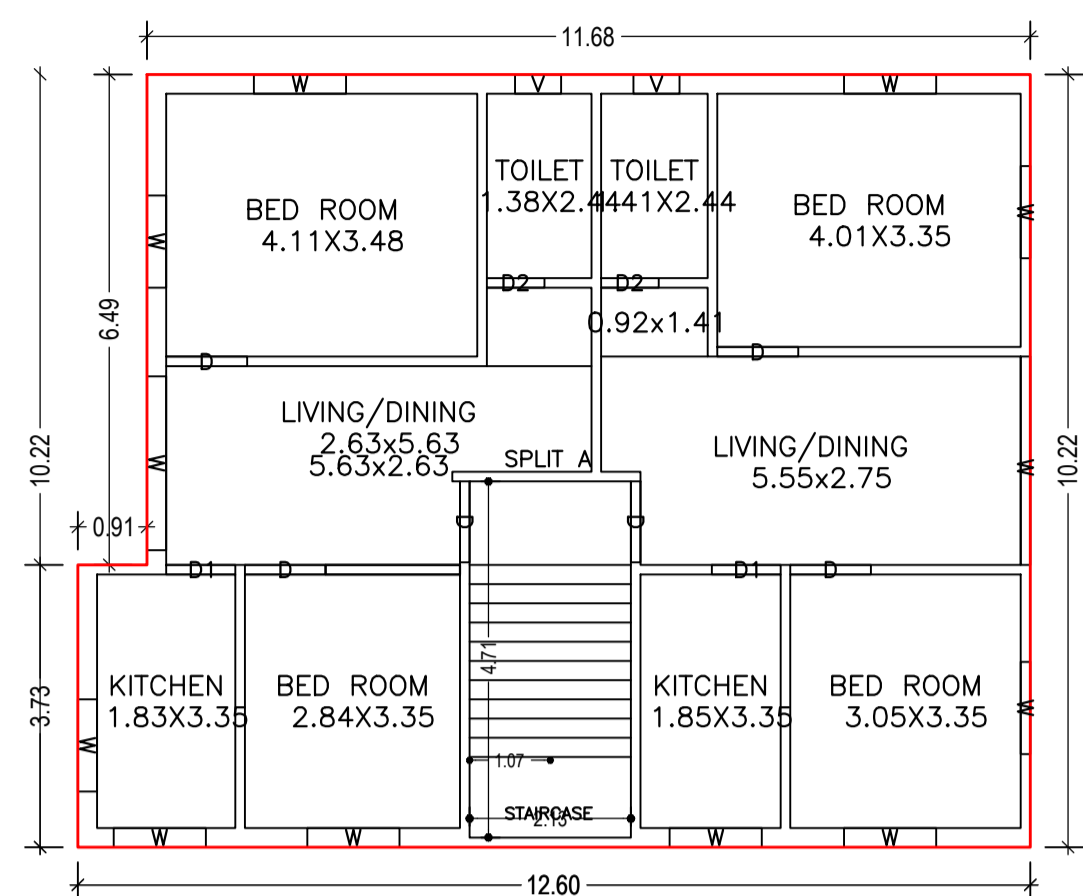
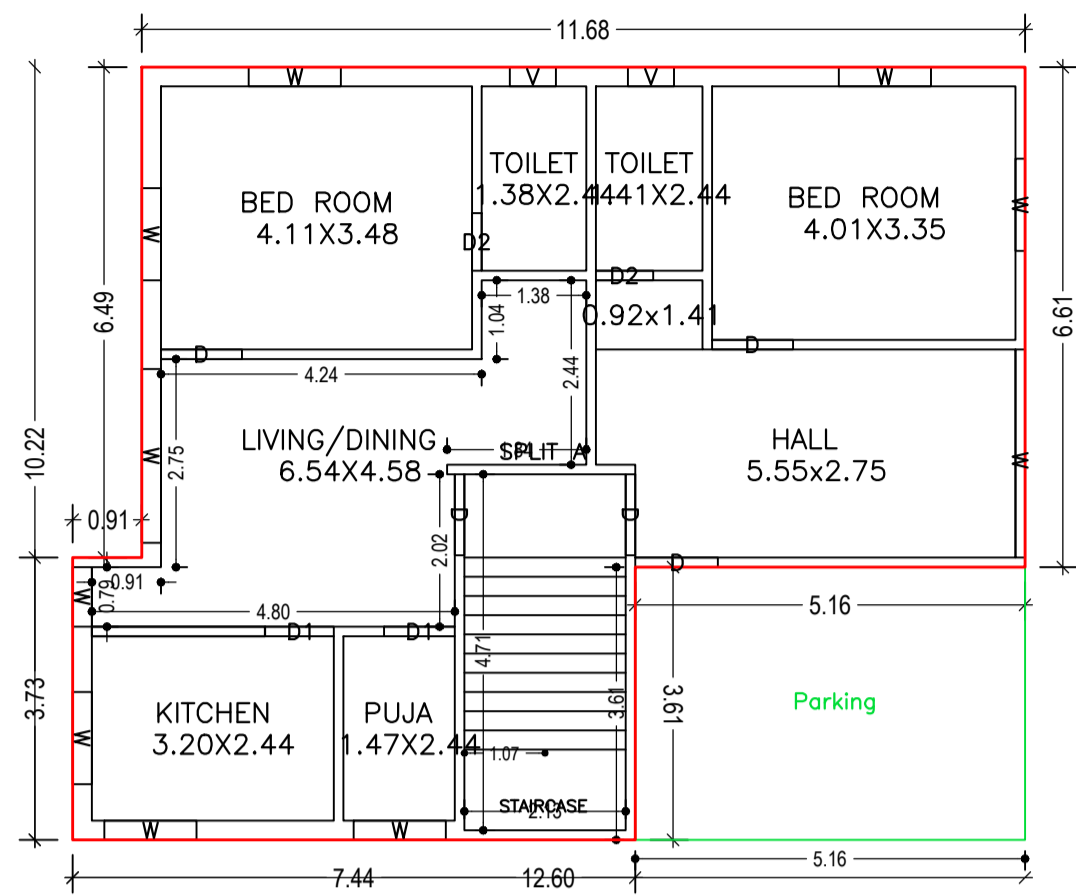

WATER HARVESTING

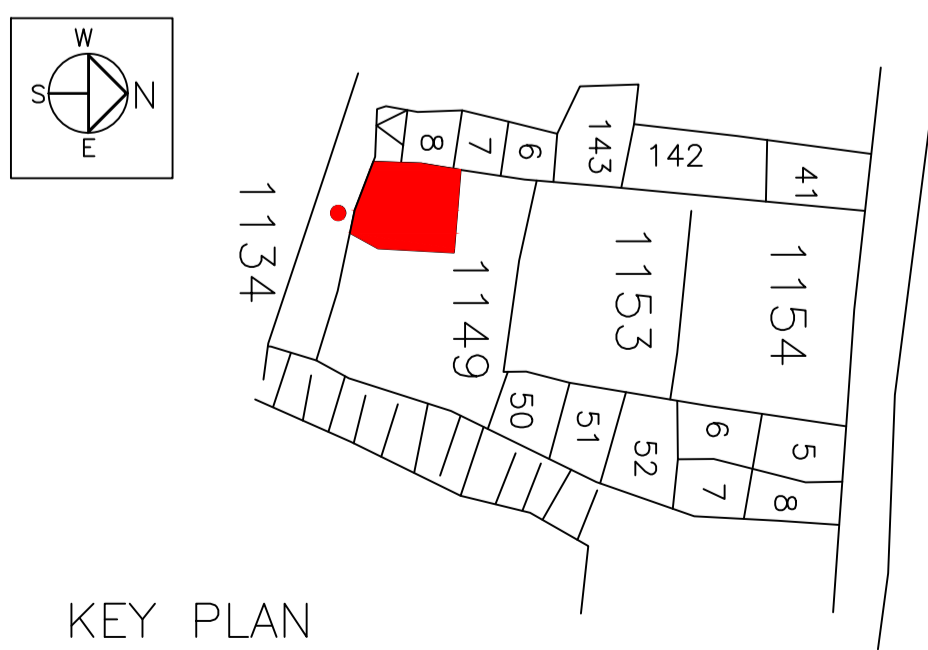

LOCATION PLAN

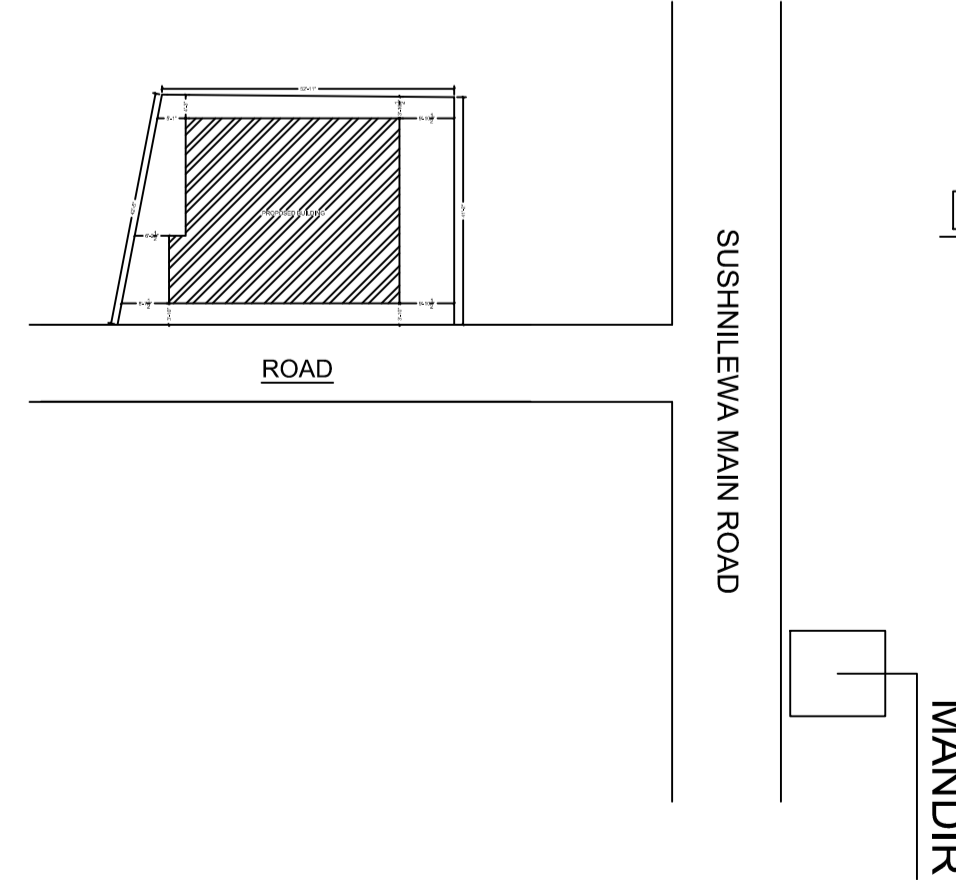

LTP NAME AND SIGNATURE	STRUCTURAL ENG'S NAME AND SIGNATURE	BUILDER NAME AND SIGNATURE	DIGITAL SIGNATURE
PARTHA PAL DMC/ENG/0021/2016			