

Project Title : VIJAY KUMAR MANDAL

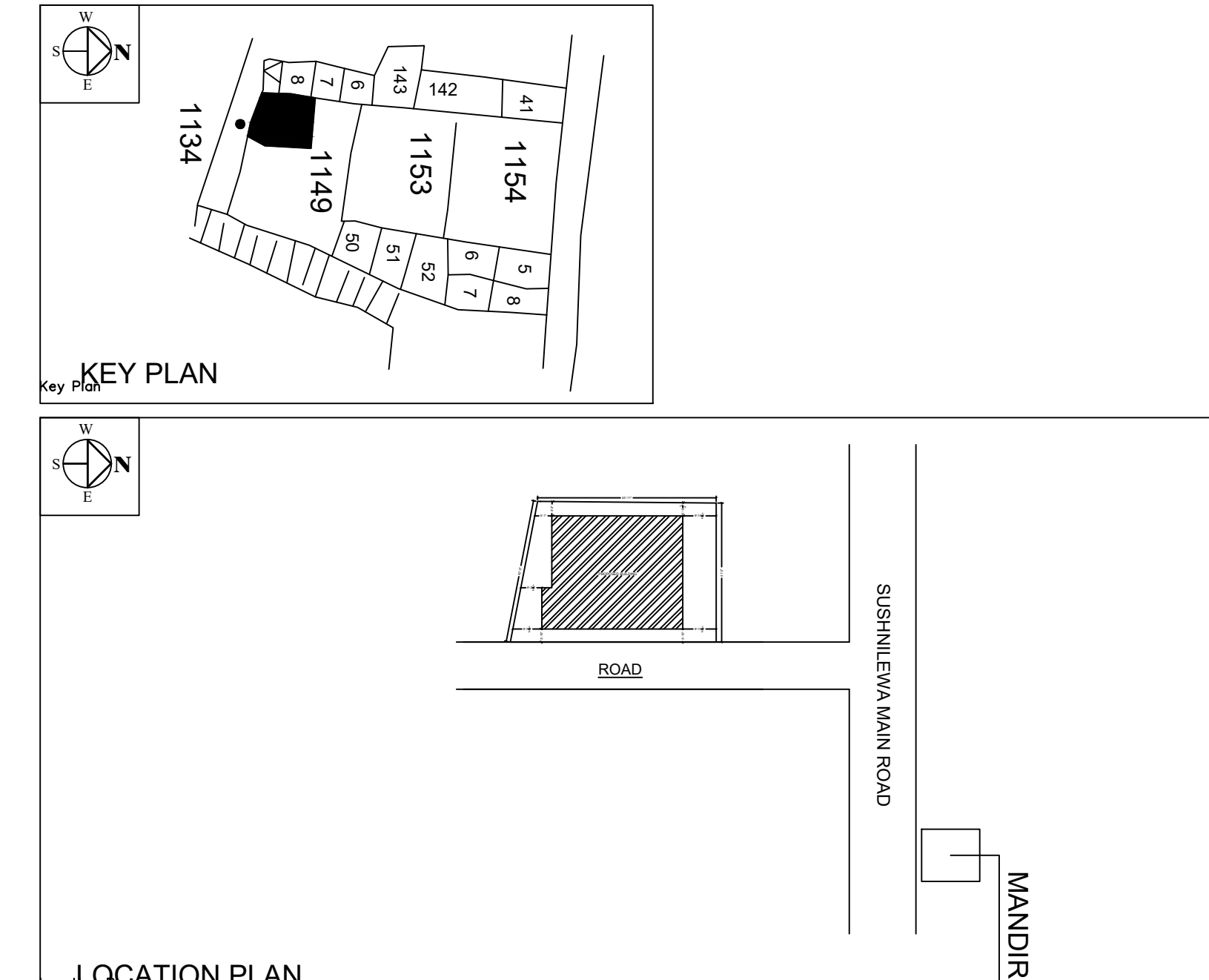
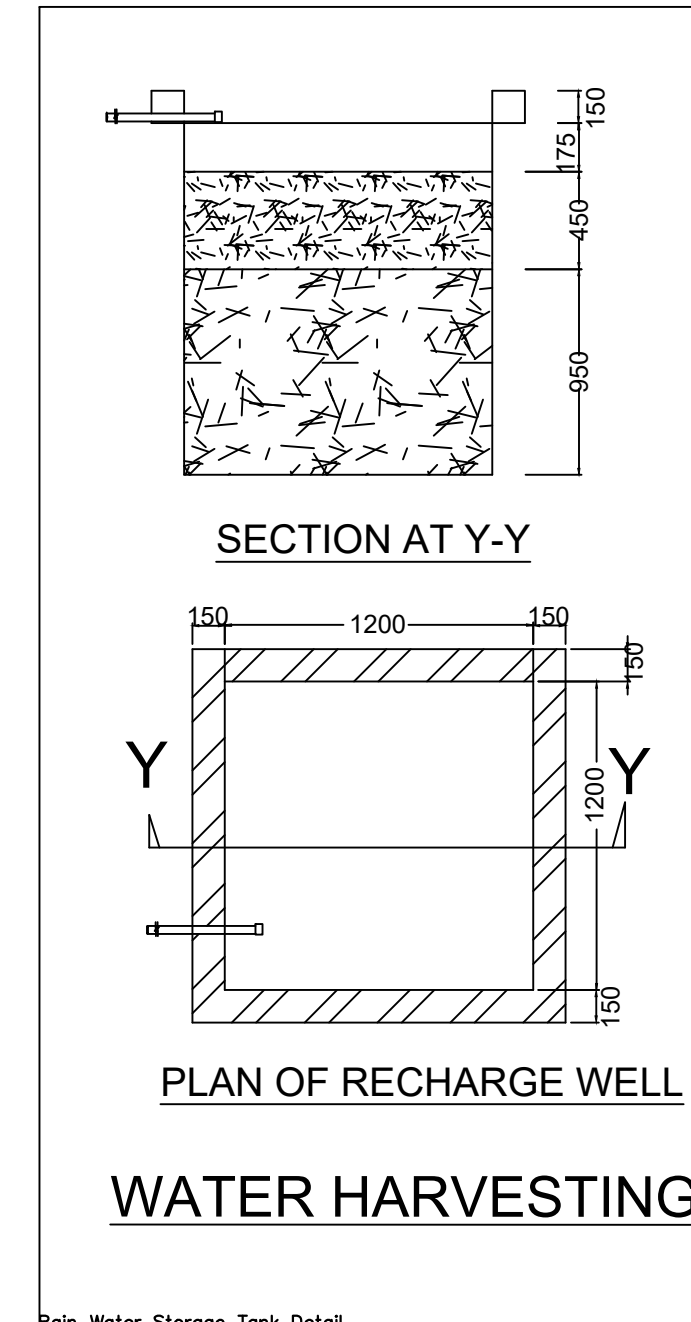
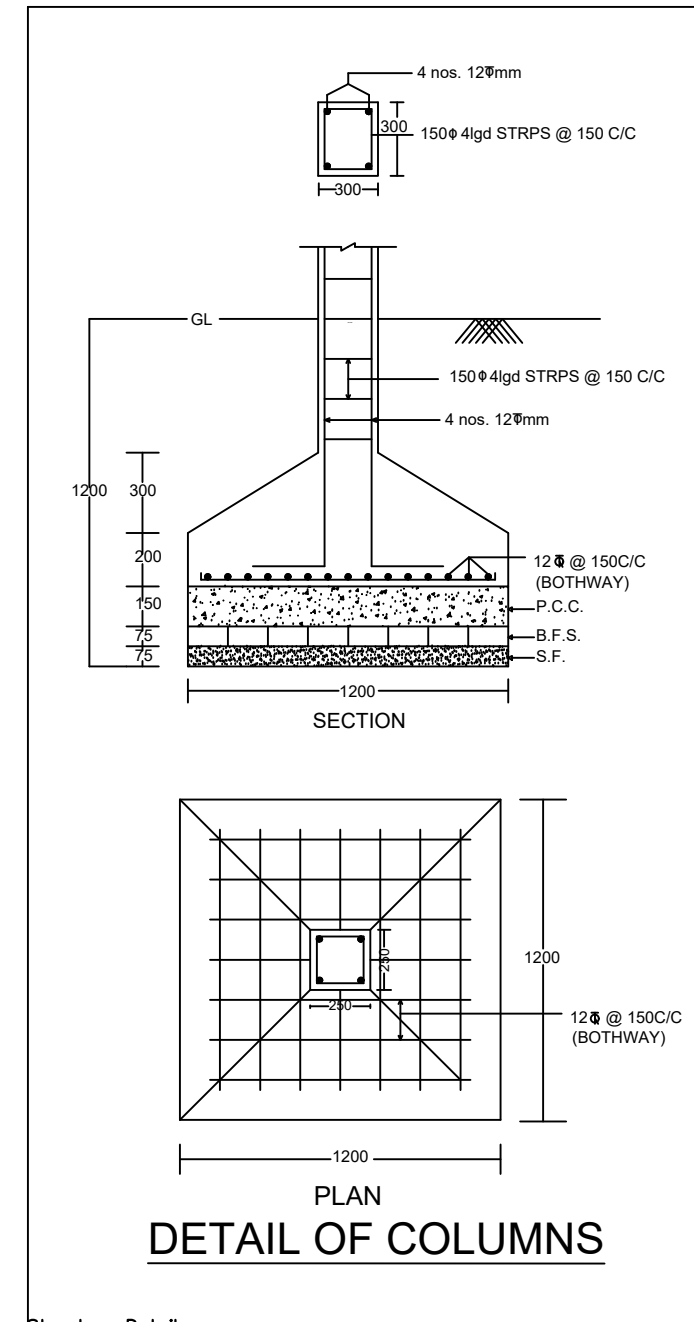
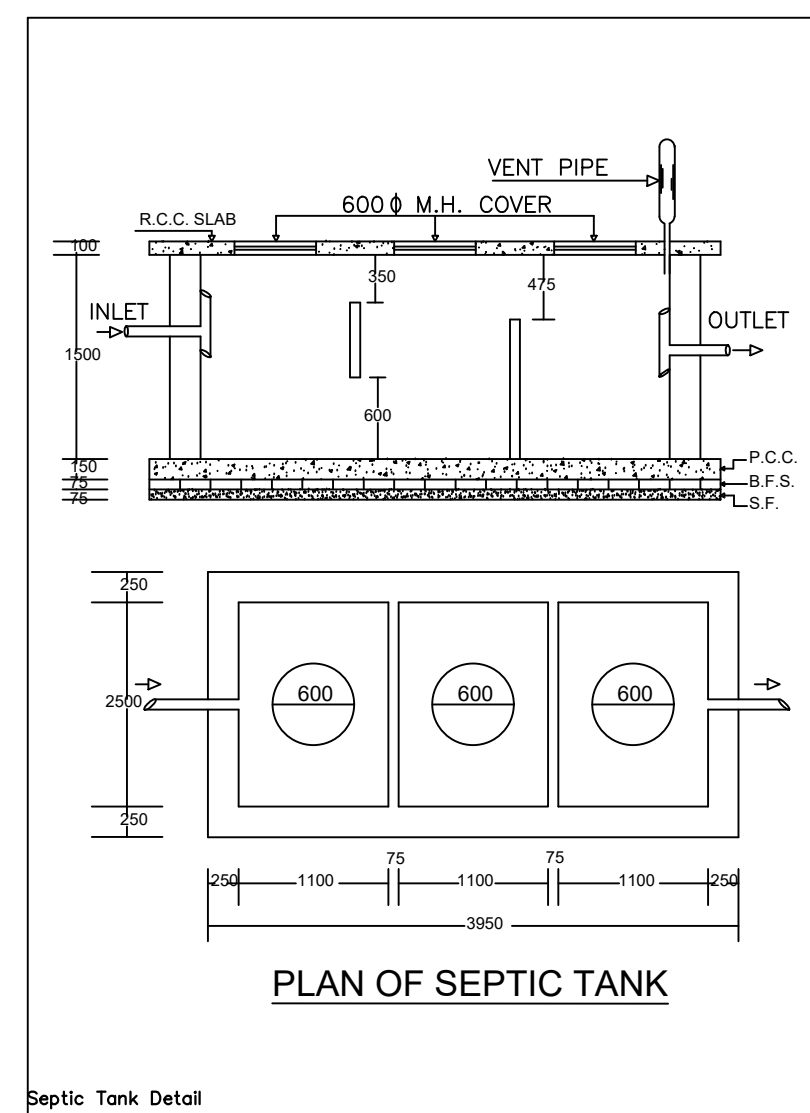
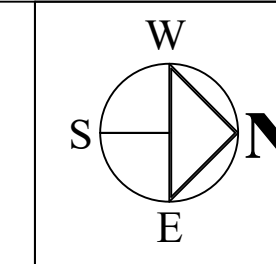
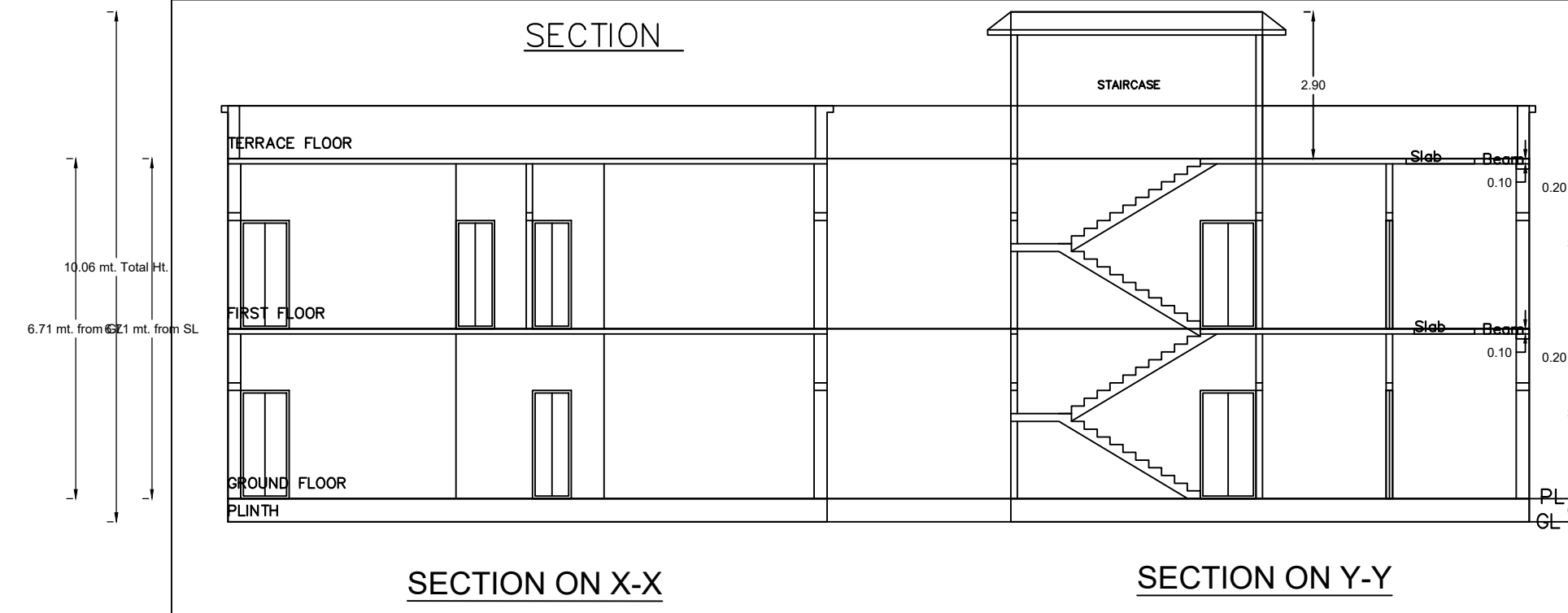
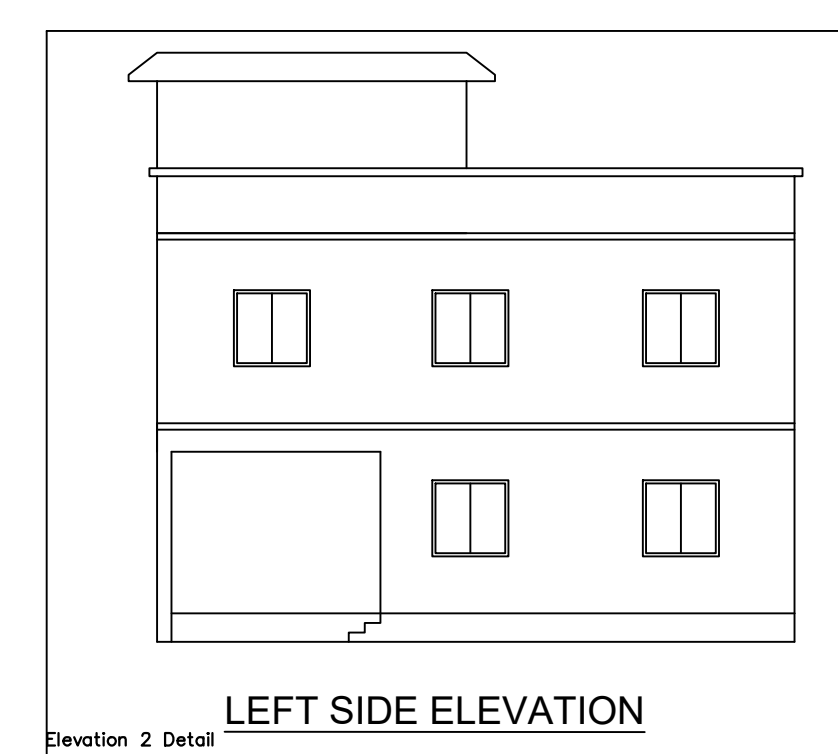
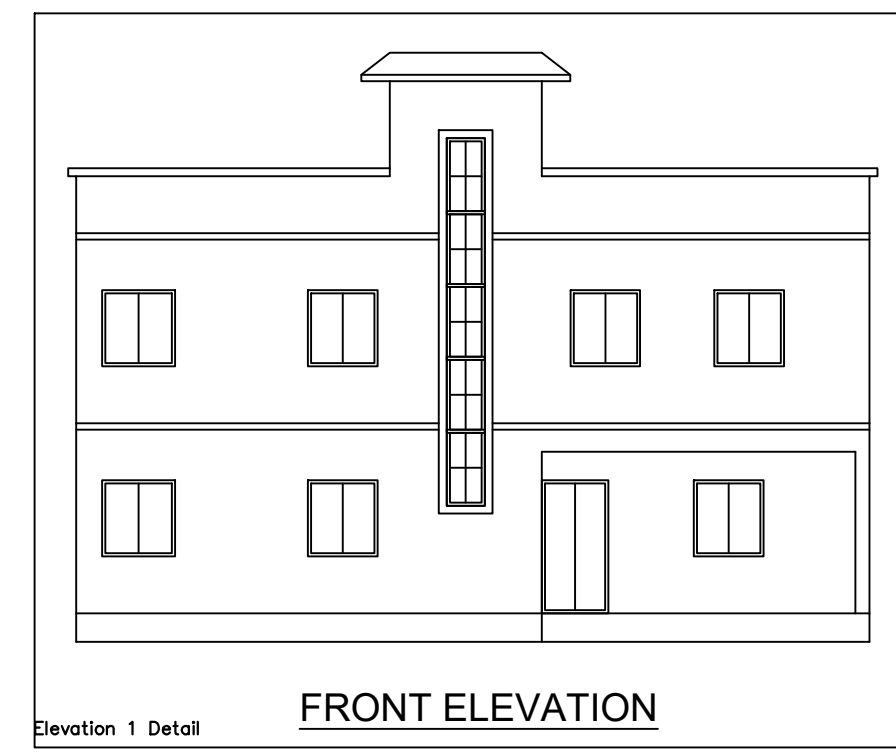

BRIEF SPECIFICATION

FOUNDATION..... CEMENT CONCRETE (1:1.5:3)
 BRICK WORK IN FOUNDATION & SUPERSTRUCTURE
 FIRST CLASS BRICK WORK IN CEMENT MORTAR (1:6)
 D.P.C.....25 D.P.C. IN CEMENT MORTAR (1:2:4)
 FLOOR.....25 P.S. OVER 75 P.C.C.
 ROOF.....100 THK. R.C.C. ROOF (1:1.5:3)
 UNTEEL.....150 THK. R.C.C. UNTEEL (1:1.5:3)
 STAIRS.....RISE-150, TREAD- 250

DETAILS OF AREA

TOTAL AREA (AS PER SITE)..... 229.86 Sq.Mt.
 TOTAL AREA (AS PER SITE)..... 219.16 Sq.Mt.
 GROUND FLOOR AREA..... 124.12 Sq.Mt.
 FIRST FLOOR AREA..... 124.12 Sq.Mt.
 TOTAL COVERED AREA..... 248.24 Sq.Mt.
 % PLINTH AREA..... 60.20 %
 FAR..... 1.38

SCHEDULE

D = 1.200X2.100	W = 1.800X1.200
D1 = 1.050X2.100	W1 = 2.400X1.200
D2 = 0.900X2.100	V = 0.600X0.600

TITLE OF DRAWING

PLAN OF PROPOSED RESIDENTIAL BUILDING OF SRI. VIJAY KUMAR MANDAL S/O BASU DEO MANDAL OF NEAR MIDDLE SCHOOL KHARIO, VILLA KHERIO, P.O. KHARIO, P.S. - HARIHAR PUR GOMOH, DIST- DHANBAD, UNDER MOUZA - SUSHNILEWA, NO. - 88, KHATA NO.- 33, NEW KHATA NO. - 94 PLOT NO.- 1070 NEW PLOT NO. - 1149 IN THE DIST. OF DHANBAD (JHARKHAND).

SIGNATURE OF OWNER

SIGNATURE OF ENGINEER

SCALE ALL DIMENSION ARE IN METRE

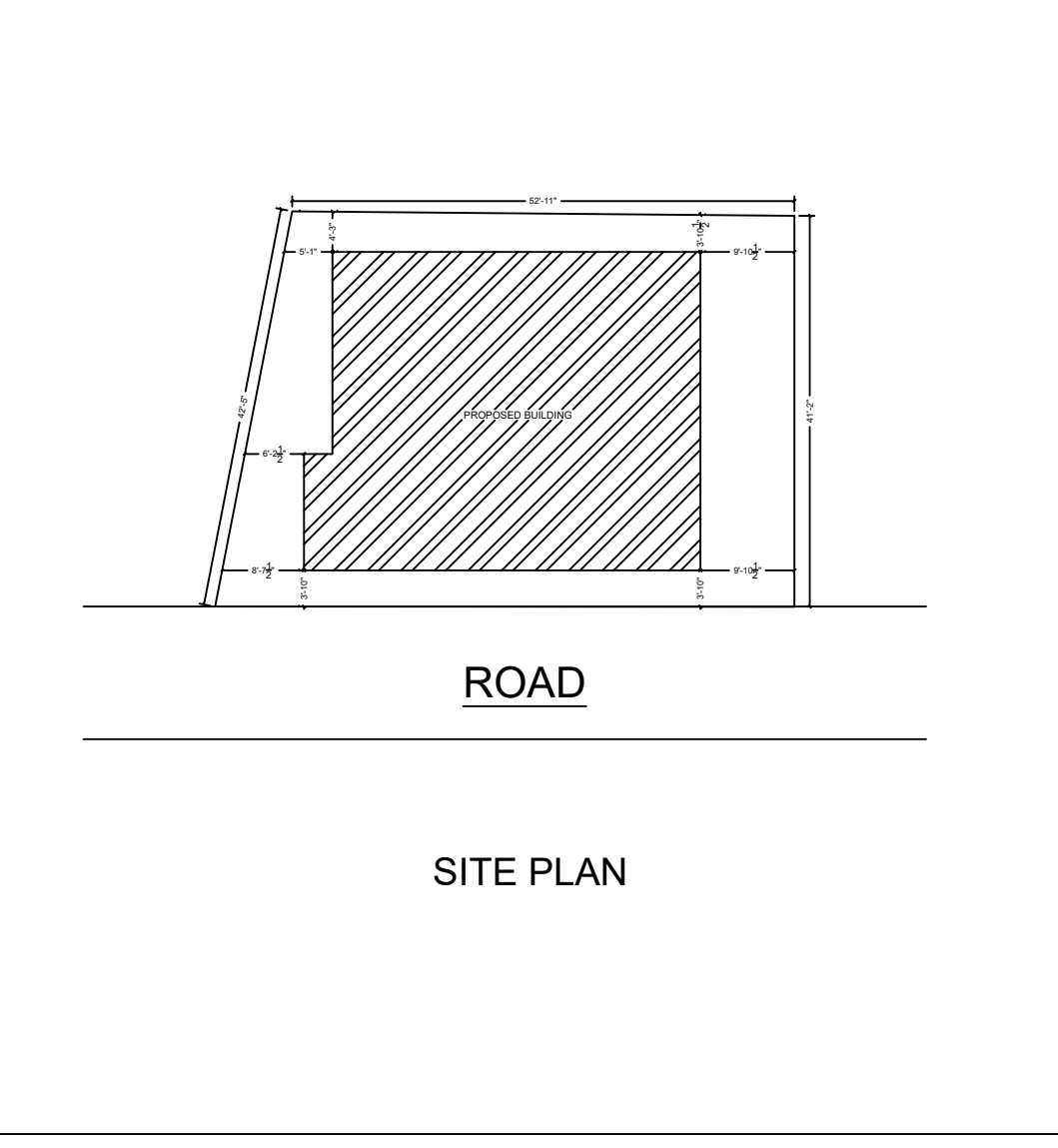
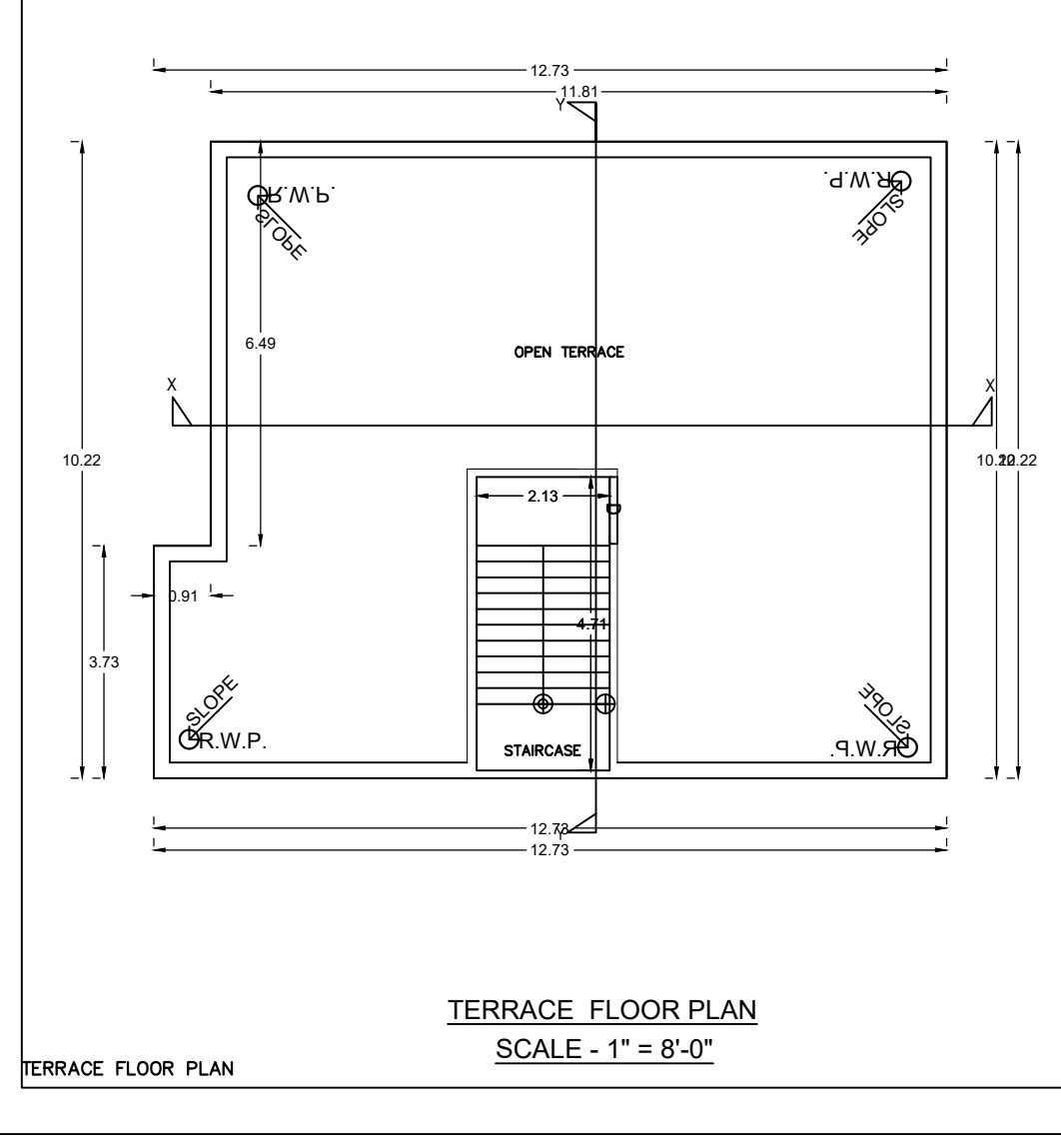
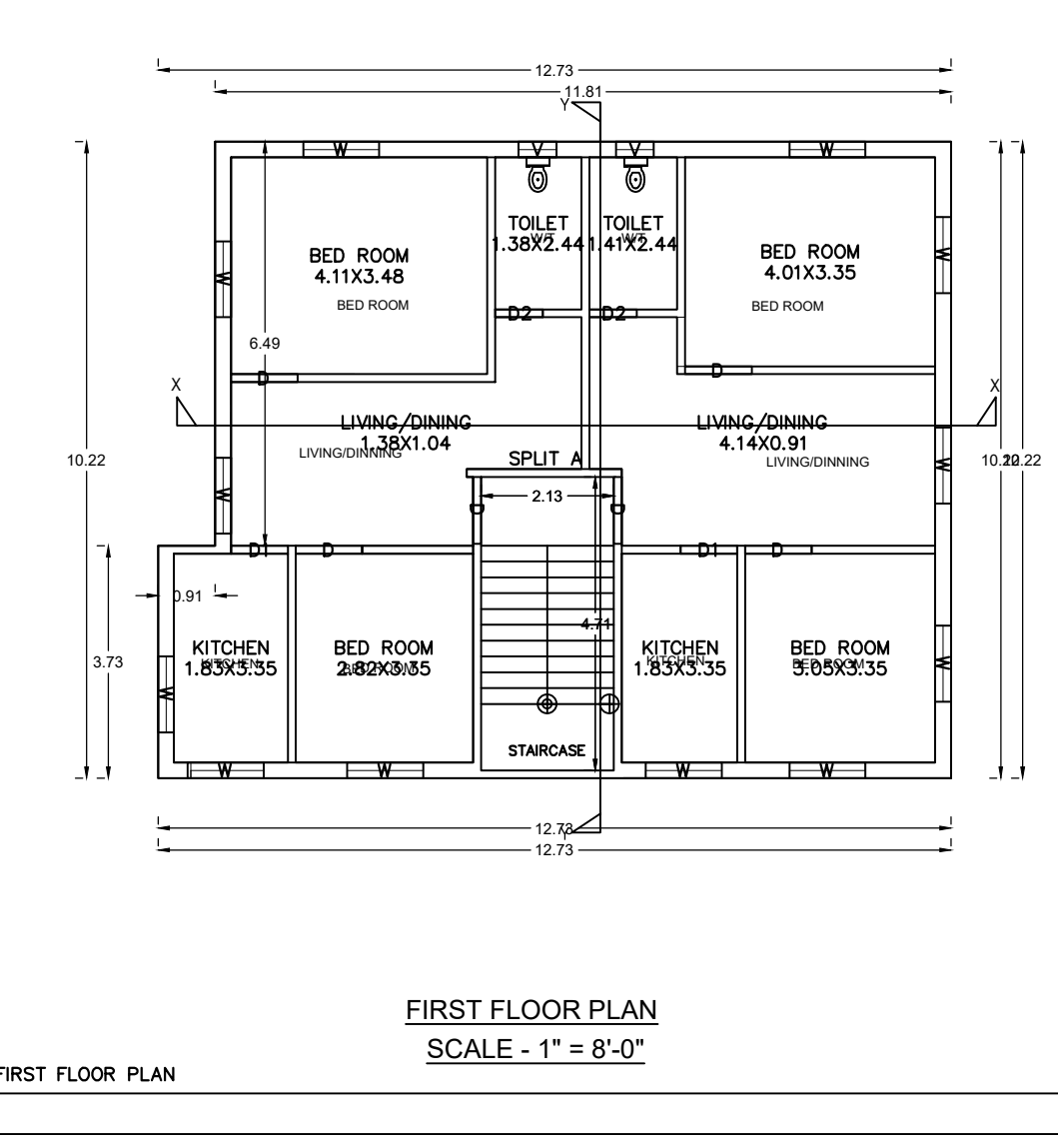
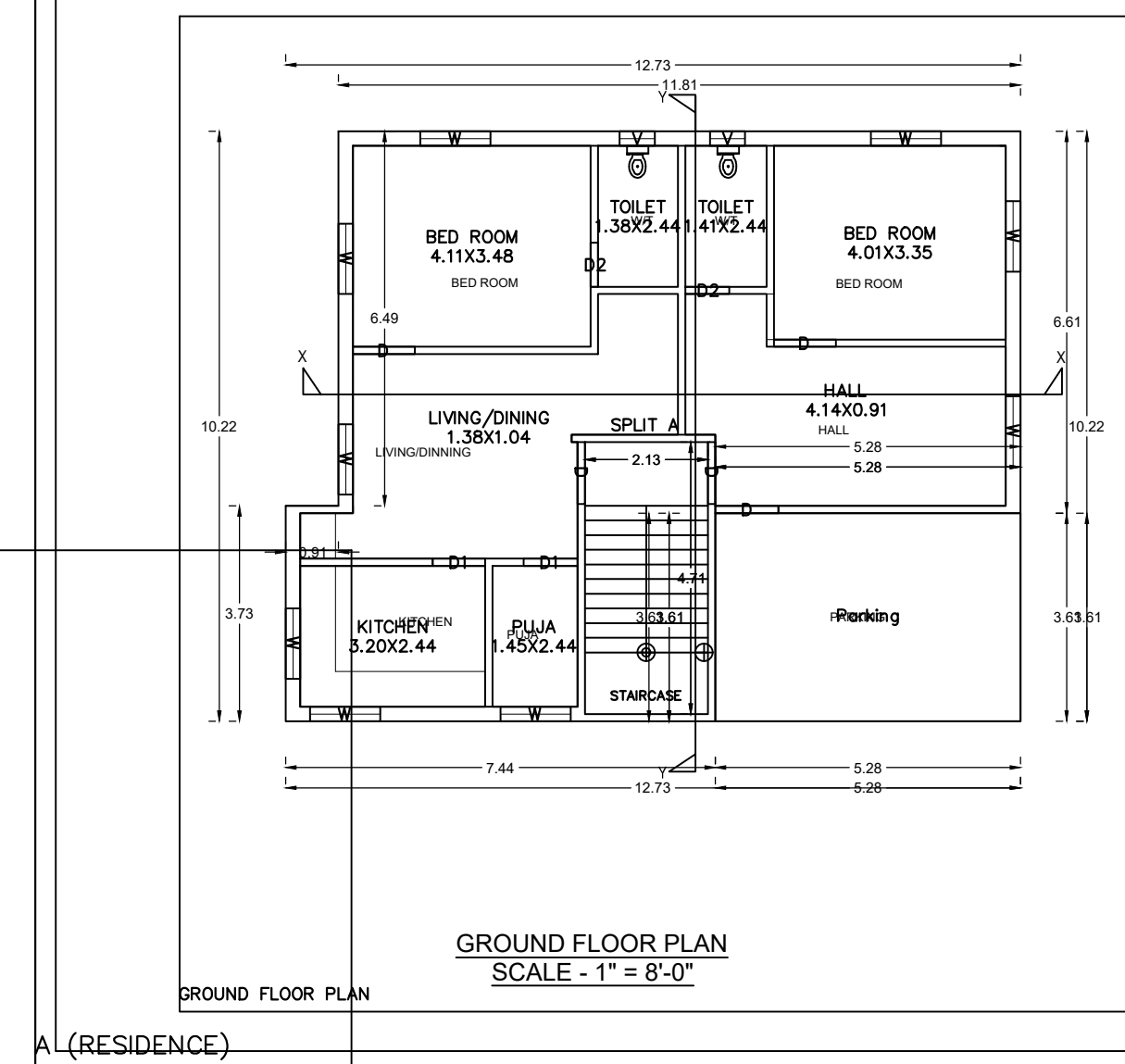
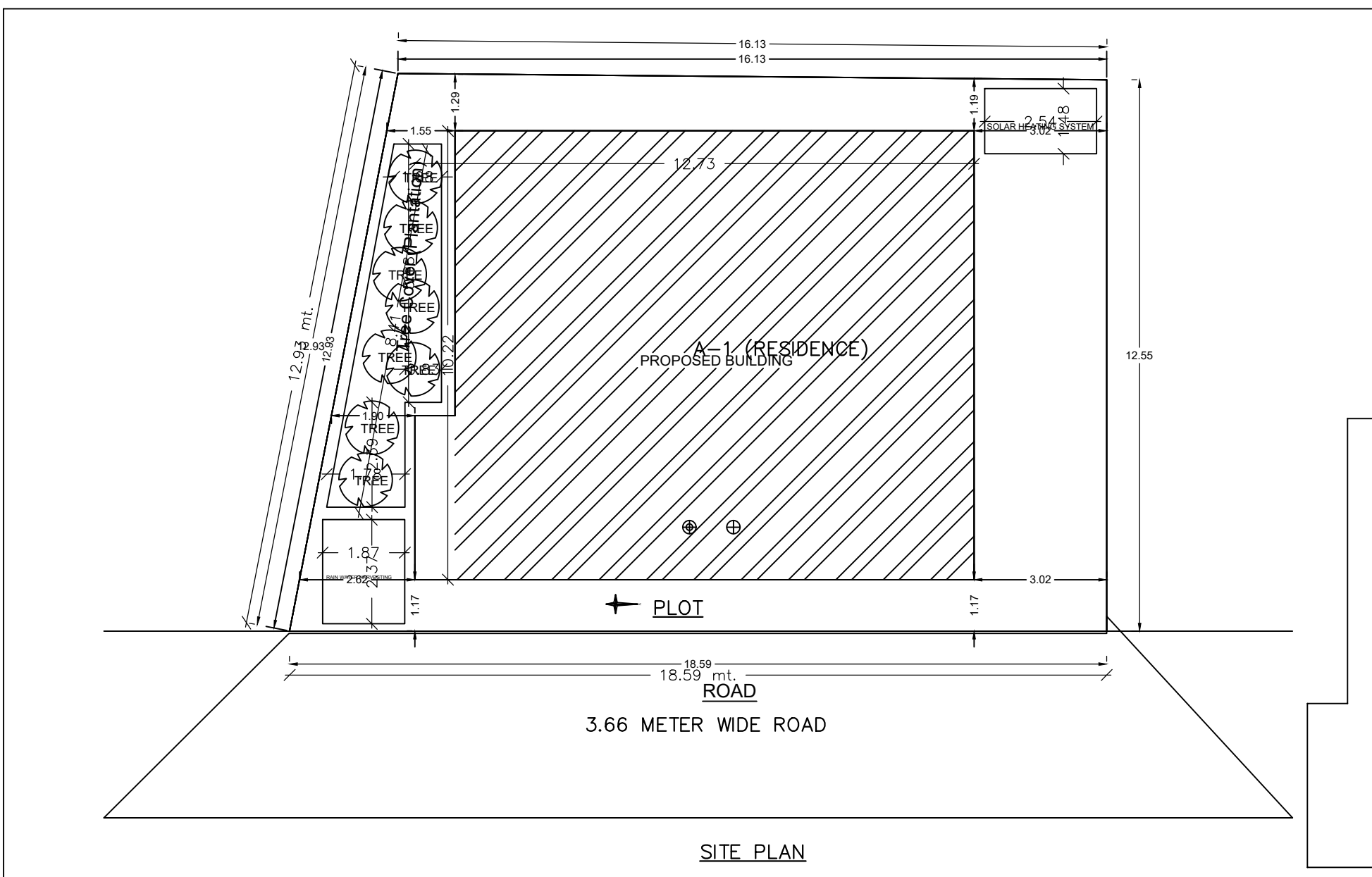

Building A (RESIDENCE)

Floor Name	Total Built Up Area (Sq.Mt)	Decks/Platform Area (Sq.Mt)	Proposed FAR Area (Sq.Mt)	Total FAR Area (Sq.Mt)	Trent (No.)
Ground Floor	124.12	0.00	124.12	124.12	01
First Floor	124.12	0.00	124.12	124.12	01
Terrace	0.00	0.00	0.00	0.00	00
Total	248.24	0.00	248.24	248.24	02

SCHEDULE OF JOINERY

ROOMING NAME	NAME	LENGTH	HEIGHT	NO.
A (RESIDENCE)	D	3.75	2.10	01
A (RESIDENCE)	D1	0.91	2.10	01
A (RESIDENCE)	D1	3.44	2.10	01
A (RESIDENCE)	D	1.07	2.10	01
A (RESIDENCE)	D	1.08	2.10	01
TOTAL	-	-	-	05

SCHEDULE OF JOINERY

ROOMING NAME	NAME	LENGTH	HEIGHT	NO.
A (RESIDENCE)	W	0.91	1.80	01
A (RESIDENCE)	W	1.22	1.22	01
TOTAL	-	-	-	02

UNBILUA Table for Building A (RESIDENCE)

FLOOR	Name	UNBILUA Type	UNBILUA Area	Carpet Area	No. of Rooms	No. of Tenement
GROUND FLOOR PLAN	SPLIT A	FLAT	166.67	166.67	0	1
TOTAL	-	-	166.67	166.67	0	1

AREA STATEMENT (GRAND TOTAL)

Sl. No.	Description	Area (Sq.Mt)
1	Total Plot Area	229.86
2	Total Covered Area	248.24
3	Total Plinth Area	124.12
4	Total Terrace Area	0.00
5	Total Open Area	0.00
6	Total Road Area	0.00
7	Total Water Body Area	0.00
8	Total Other Area	0.00
9	Total Area	229.86

COLOR INDEX

1	Red
2	Green
3	Blue
4	Yellow
5	Black

Color Index

1	Red
2	Green
3	Blue
4	Yellow
5	Black

Color Index

1	Red
2	Green
3	Blue
4	Yellow
5	Black

Color Index

1	Red
2	Green
3	Blue
4	Yellow
5	Black

Color Index

1	Red
2	Green
3	Blue
4	Yellow
5	Black

Color Index

1	Red
2	Green
3	Blue
4	Yellow
5	Black

Color Index

1	Red
2	Green
3	Blue
4	Yellow
5	Black

Color Index

1	Red
2	Green
3	Blue
4	Yellow
5	Black

Color Index

1	Red
2	Green
3	Blue
4	Yellow
5	Black

Color Index

1	Red
2	Green
3	Blue
4	Yellow
5	Black

Color Index

1	Red
2	Green
3	Blue
4	Yellow
5	Black

Color Index

1	Red
2	Green
3	Blue
4	Yellow
5	Black

Color Index

1	Red
2	Green
3	Blue
4	Yellow
5	Black

Color Index

1	Red
2	Green
3	Blue
4	Yellow
5	Black

Color Index

1	Red
2	Green
3	Blue
4	Yellow
5	Black