

Proposal Basic Information	
Proposal File No.	DMC/BP/0233/W21/2024
Owner Name	SARITA DEVI
Khata No	90
Plot No	9,10
Village Name	Dhaiya
Use	Residential
SubUse	Bungalow/ Dwelling / Non Apartment

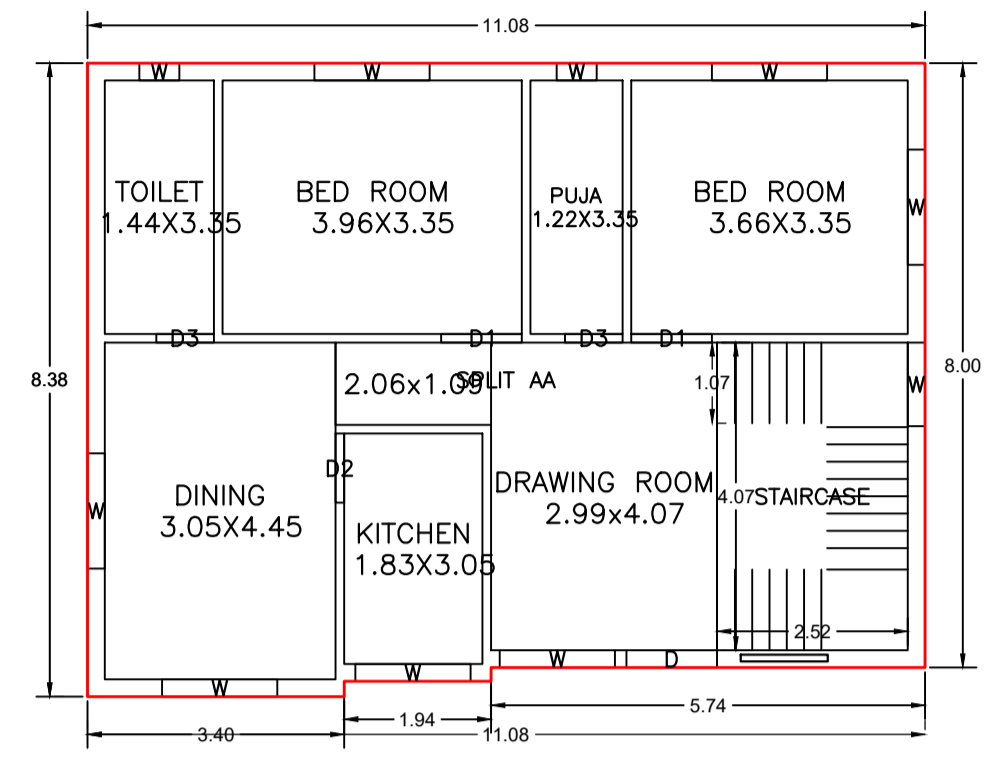

GROUND FLOOR PLAN
(Proposed)
(SCALE 1:100)

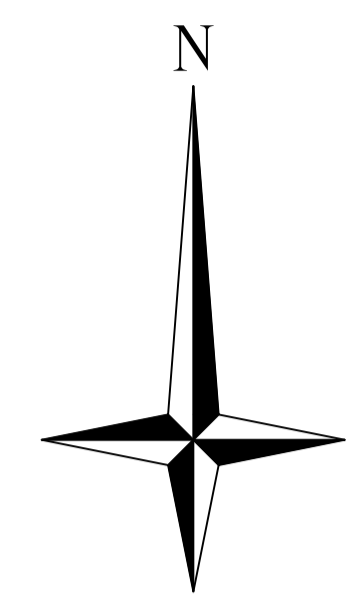
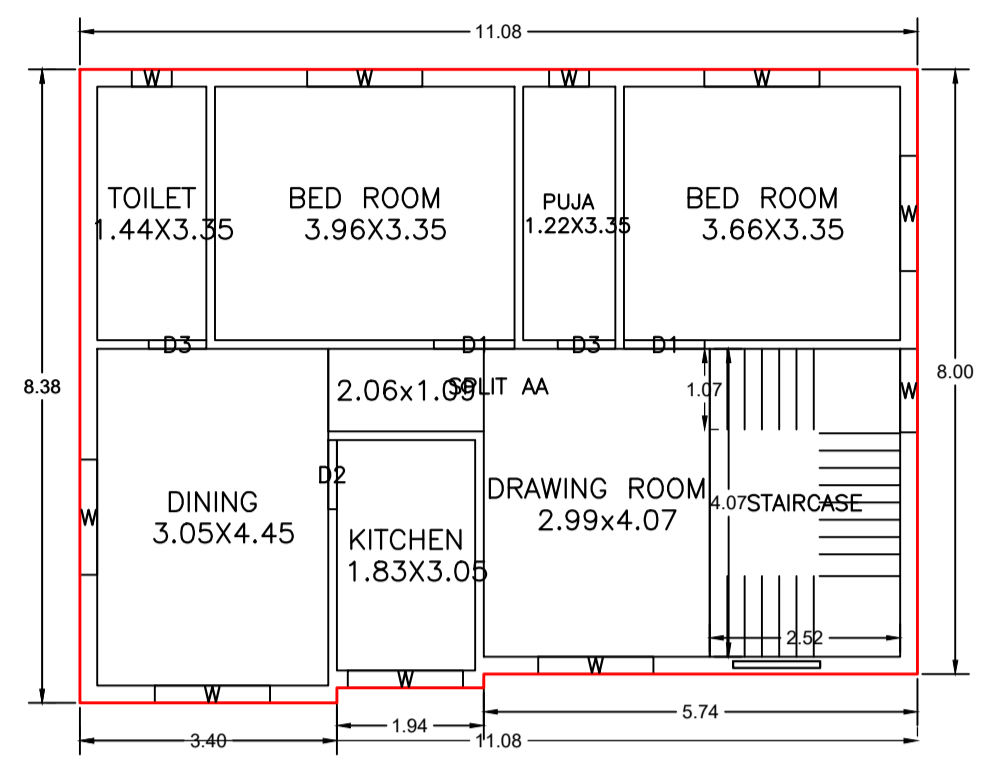

FIRST FLOOR PLAN
(Proposed)
(SCALE 1:100)

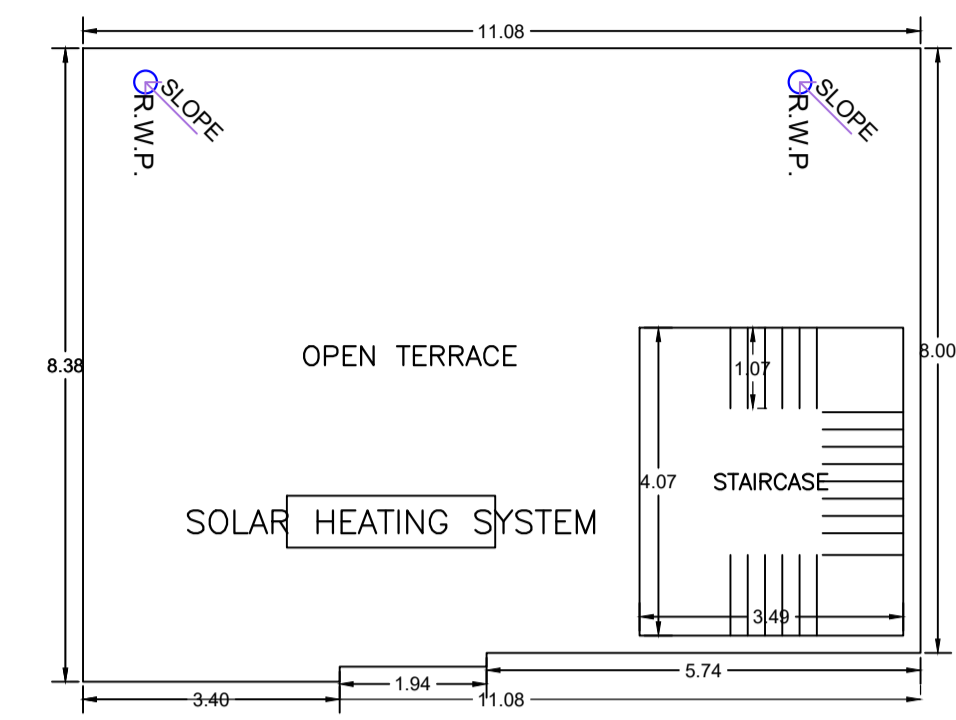

TERRACE FLOOR PLAN
(SCALE 1:100)

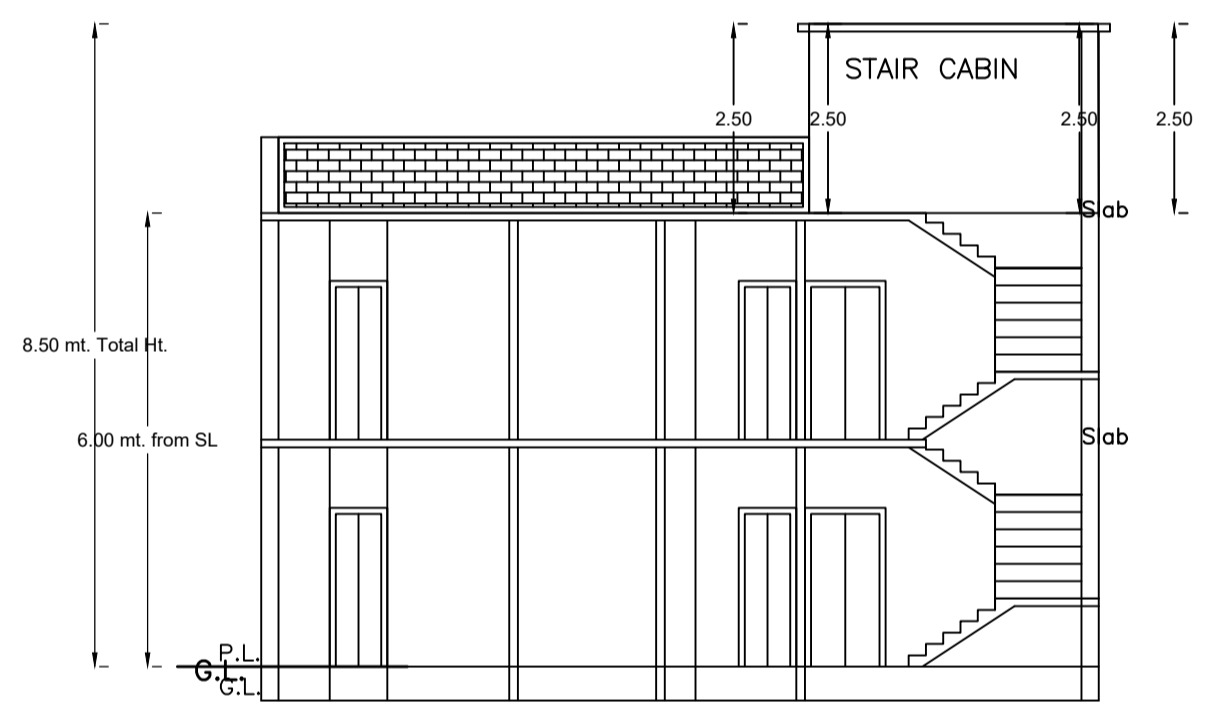

SECTION ON X-X

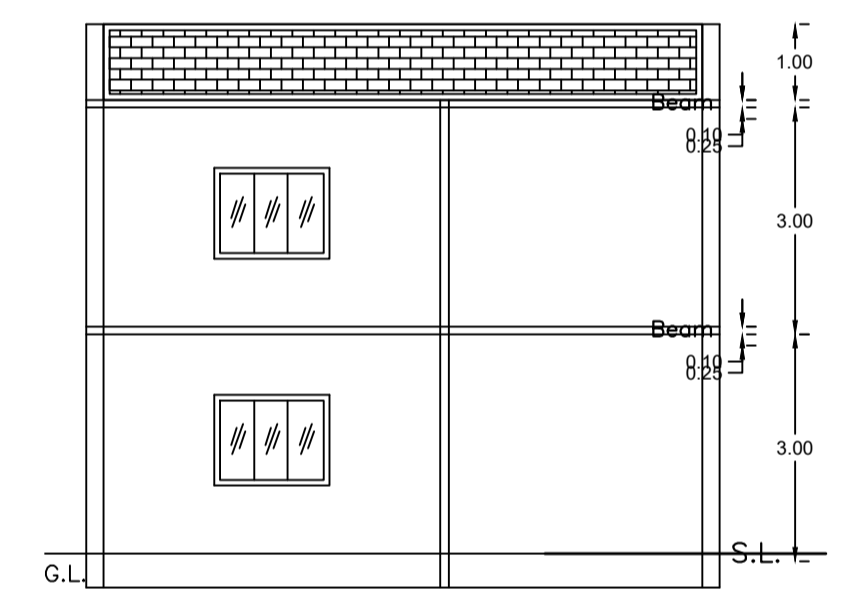

SECTION ON Y-Y

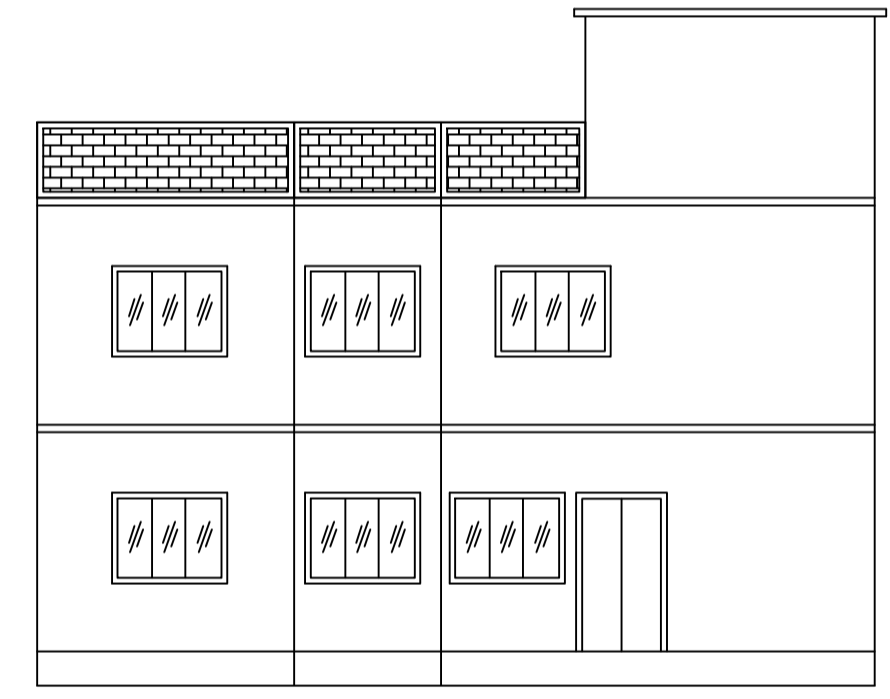

FRONT ELEVATION

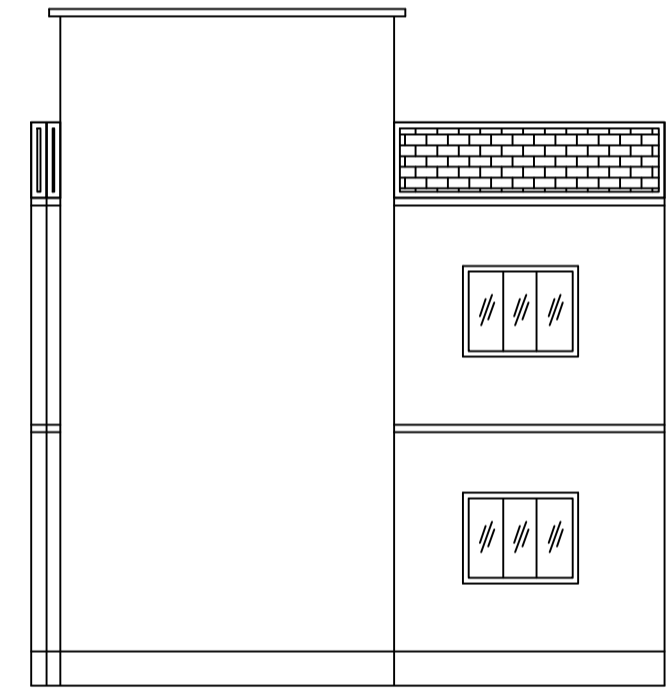

RIGHT SIDE ELEVATION

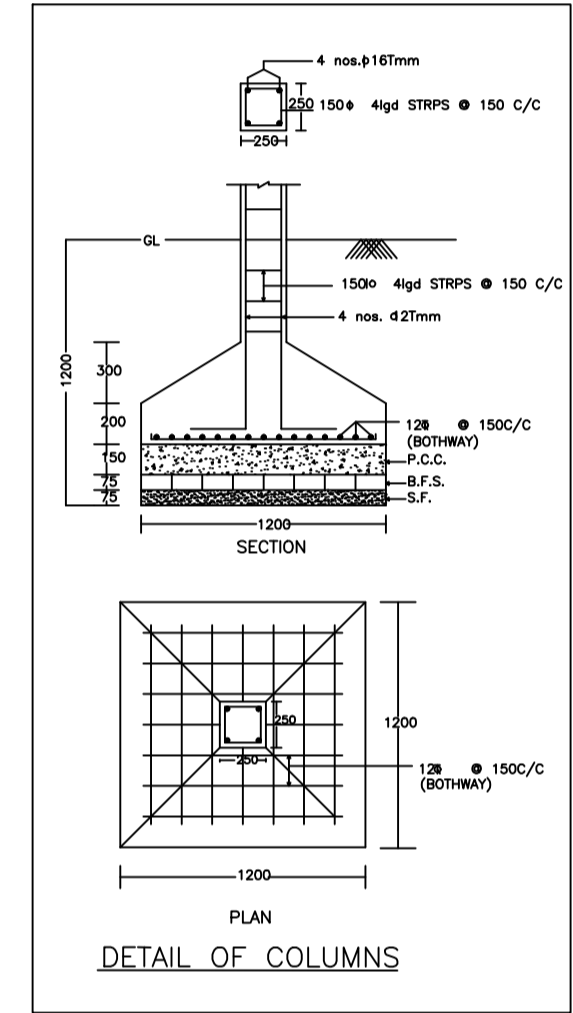

DETAIL OF COLUMNS

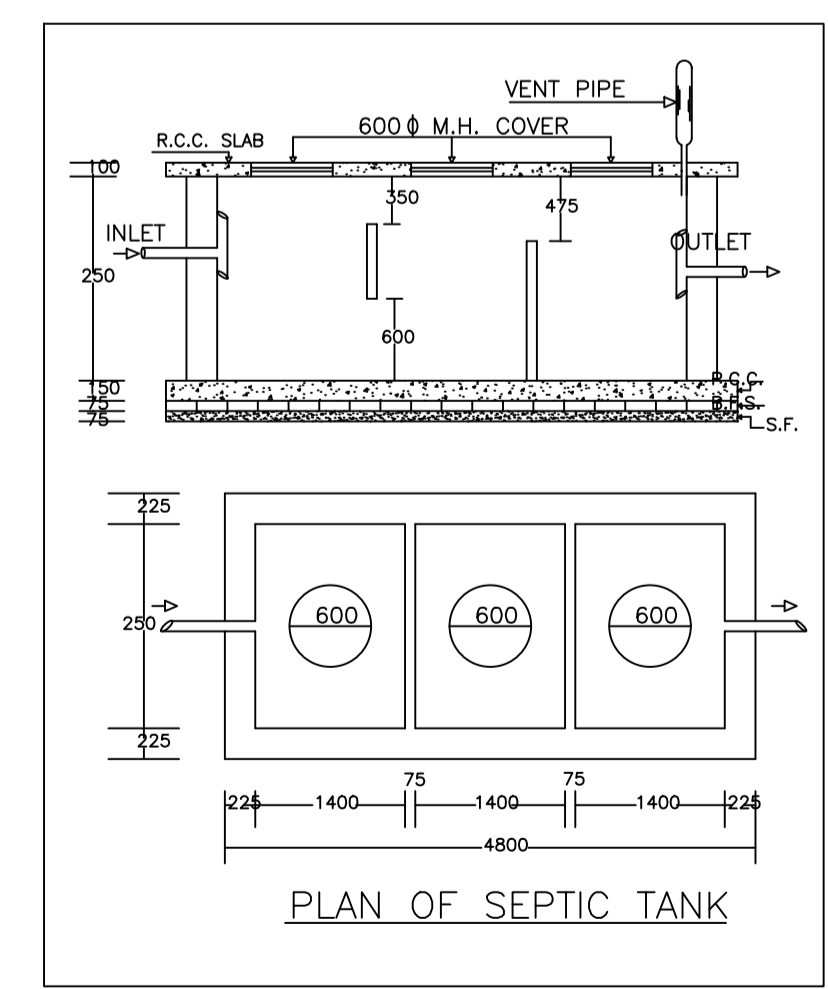

PLAN OF SEPTIC TANK

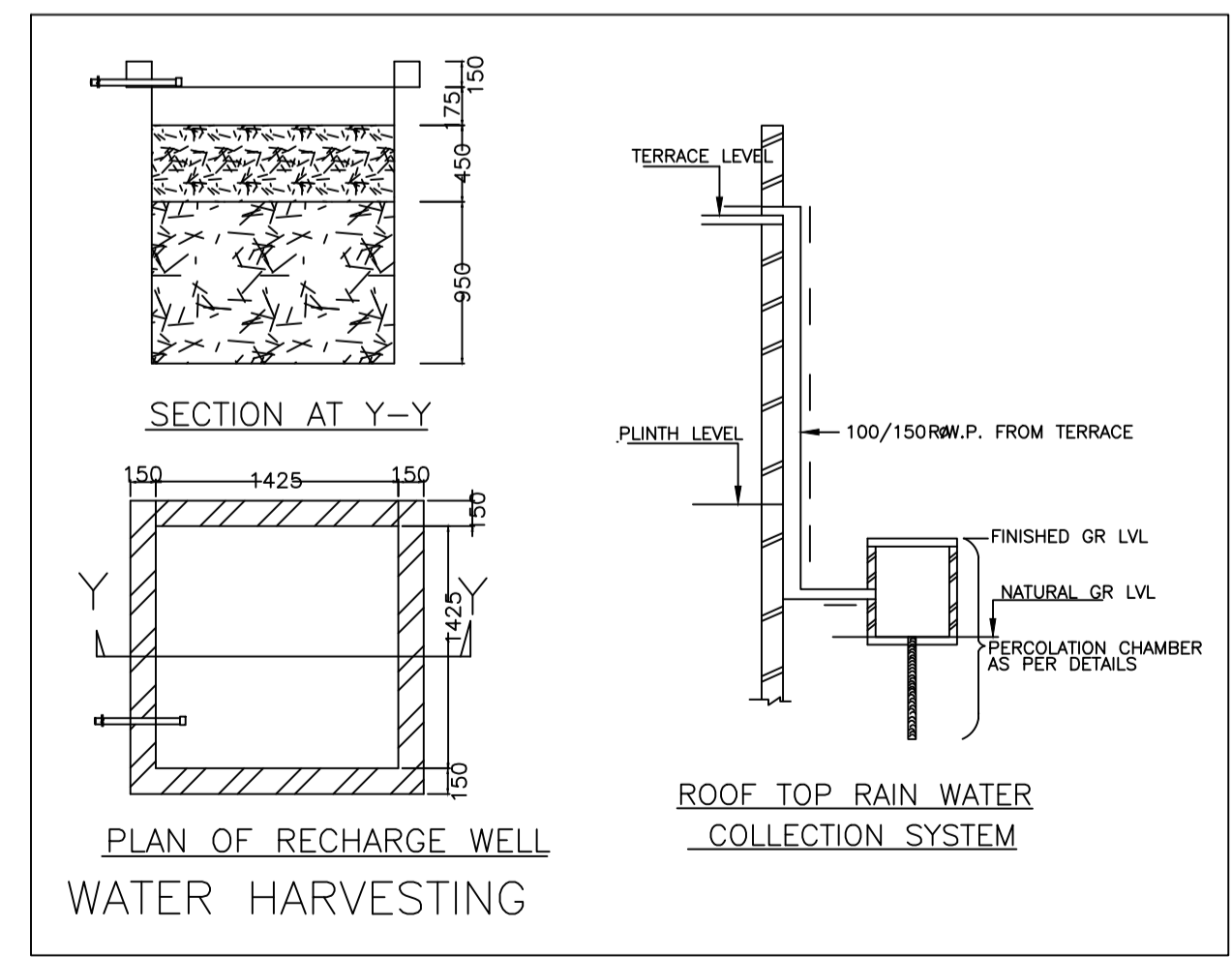

PLAN OF RECHARGE WELL
WATER HARVESTING

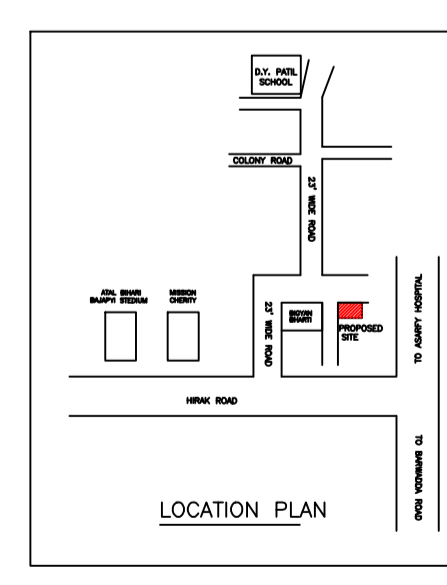

LOCATION PLAN

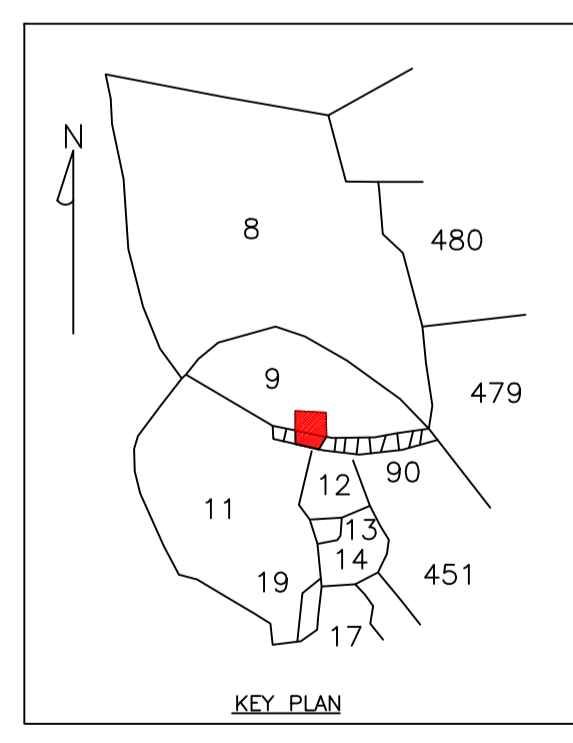

KEY PLAN

LTP NAME AND SIGNATURE	STRUCTURAL ENG'S NAME AND SIGNATURE	BUILDER NAME AND SIGNATURE	DIGITAL SIGNATURE
RAJEEV RANJAN SINGH DMC/ENG/0032/2017			