

Project Title :SMT USHA GUPTA

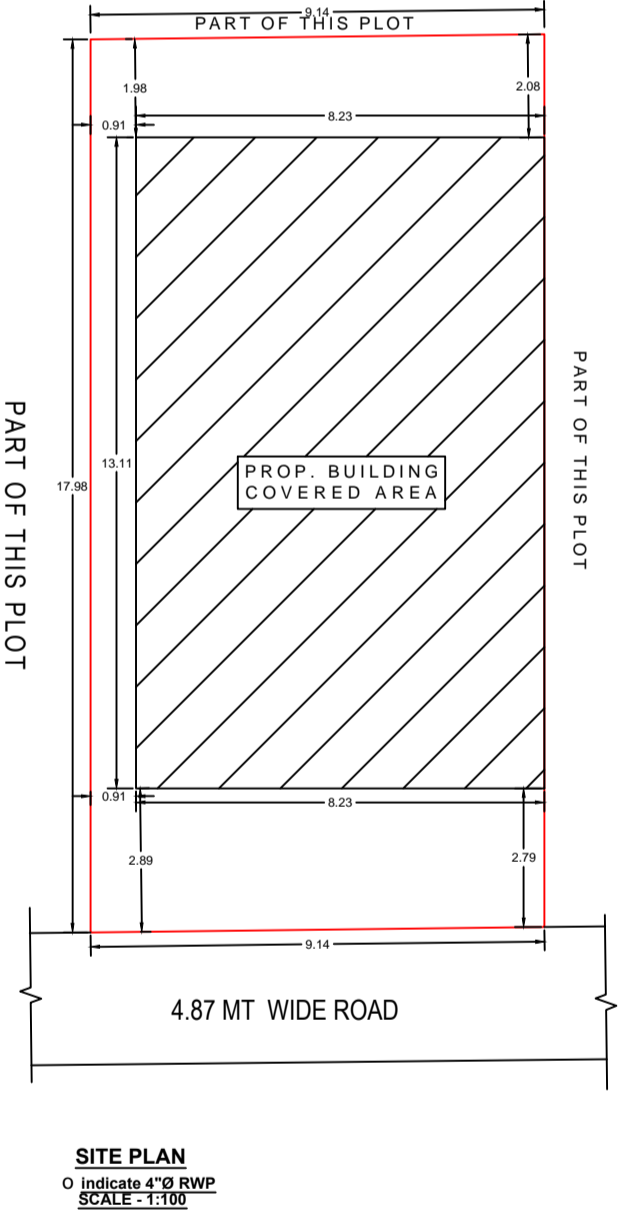
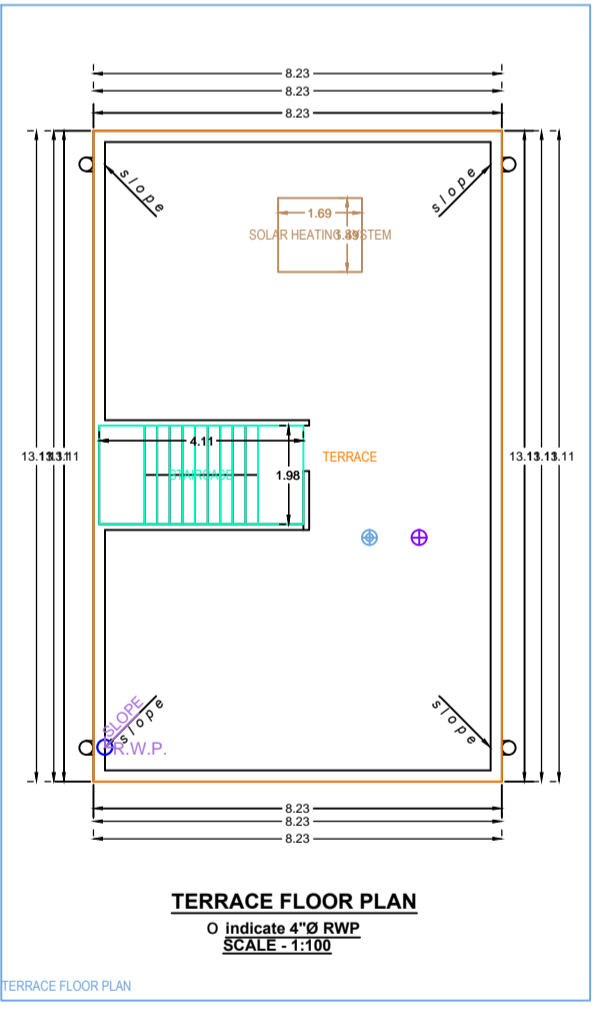
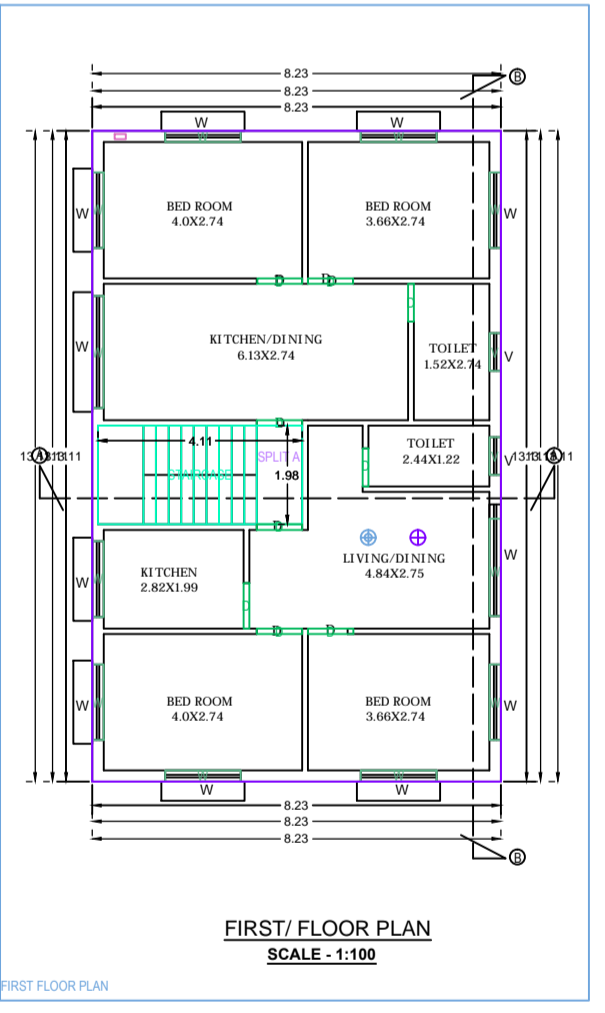
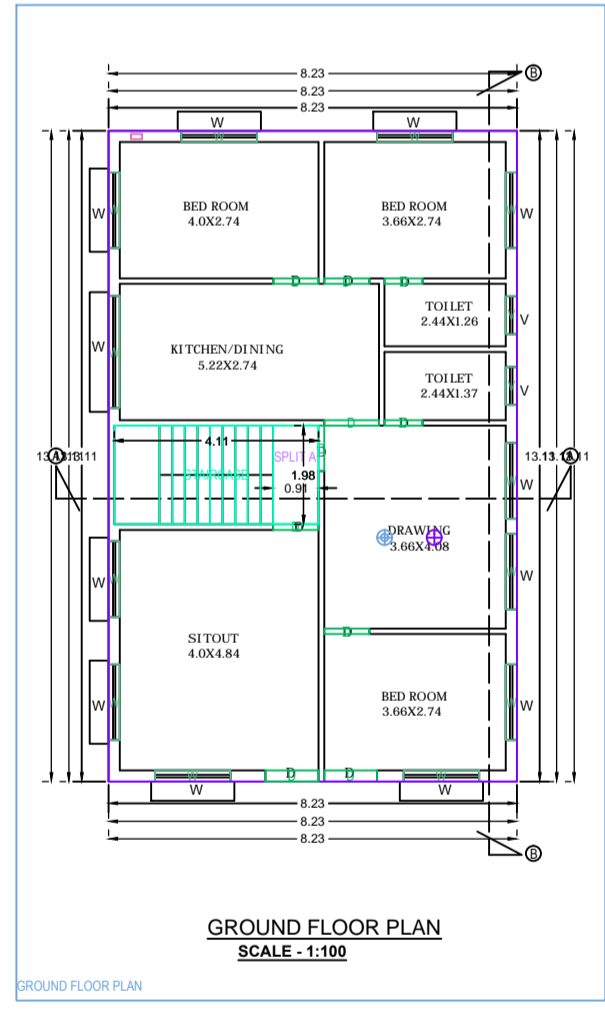
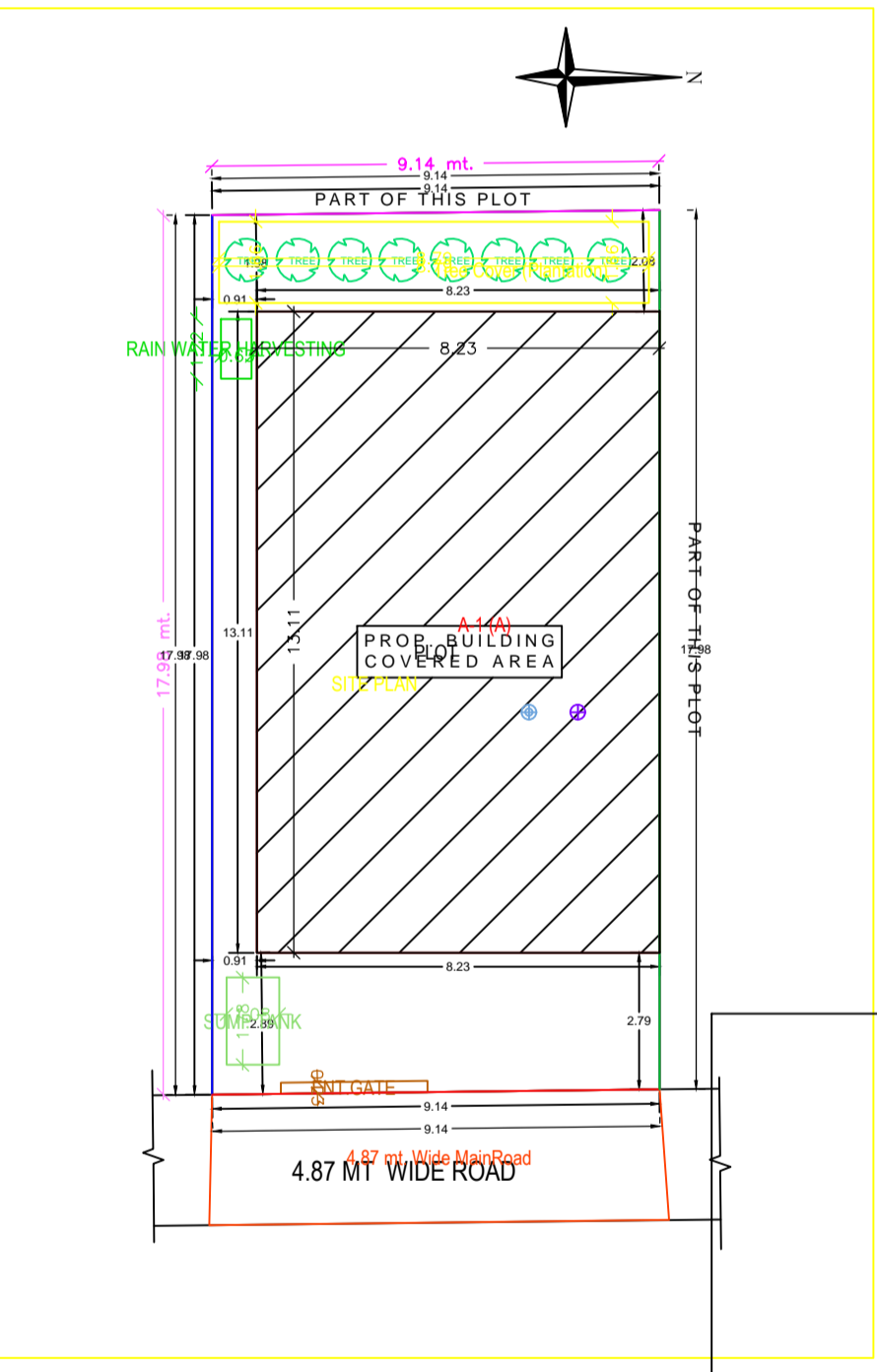
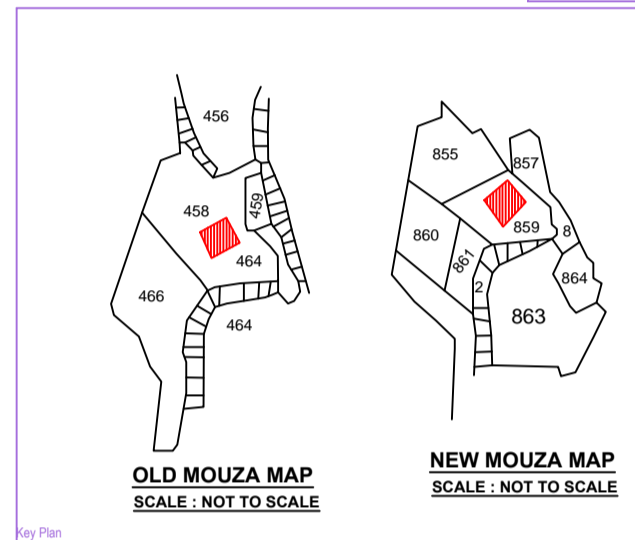
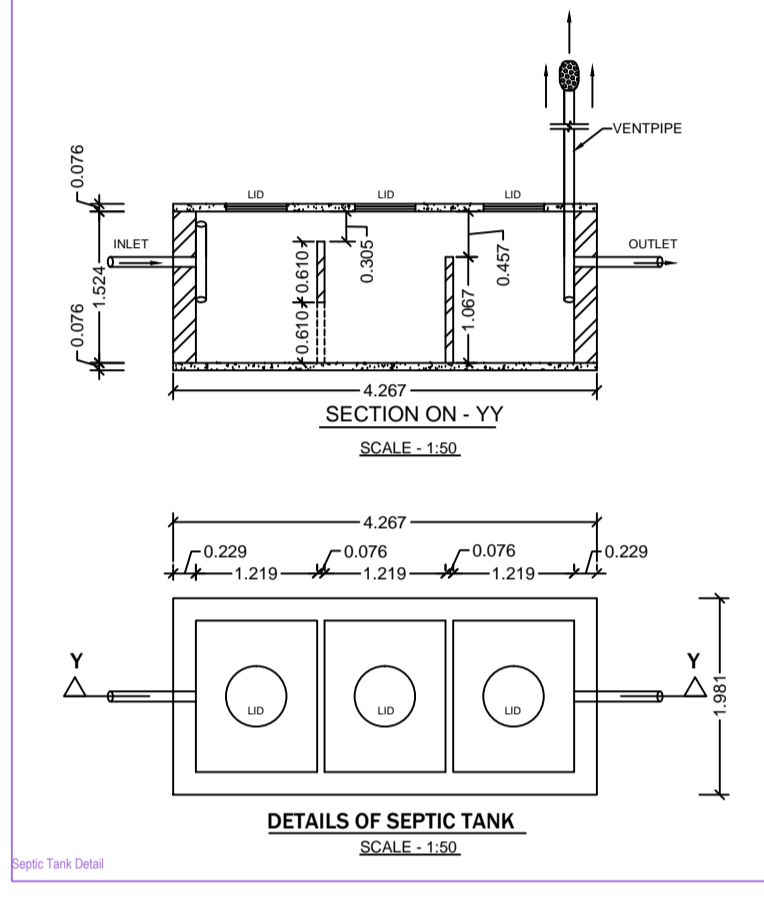
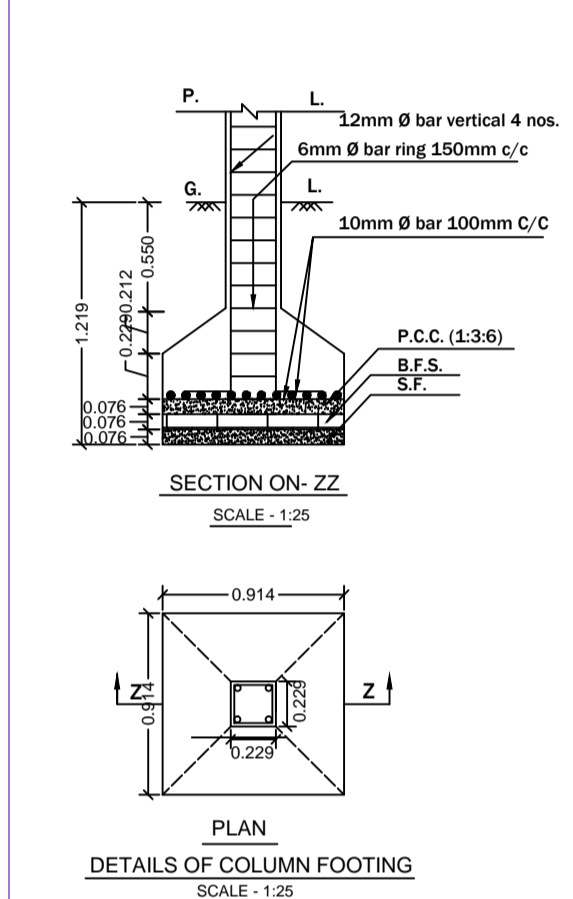
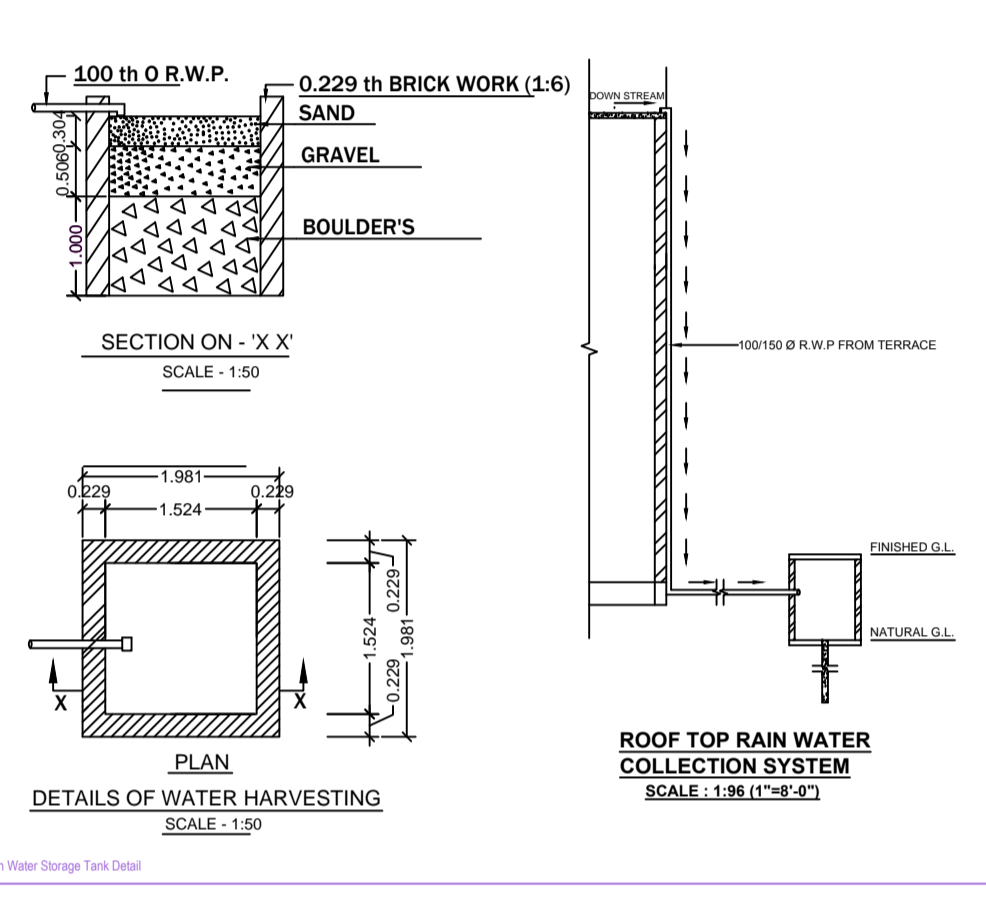
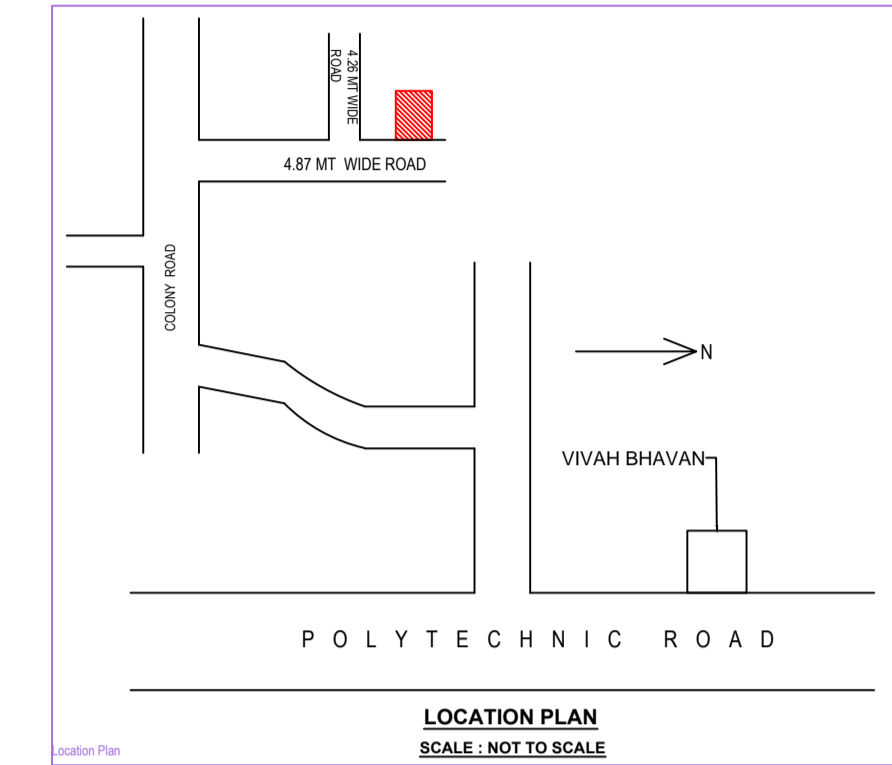
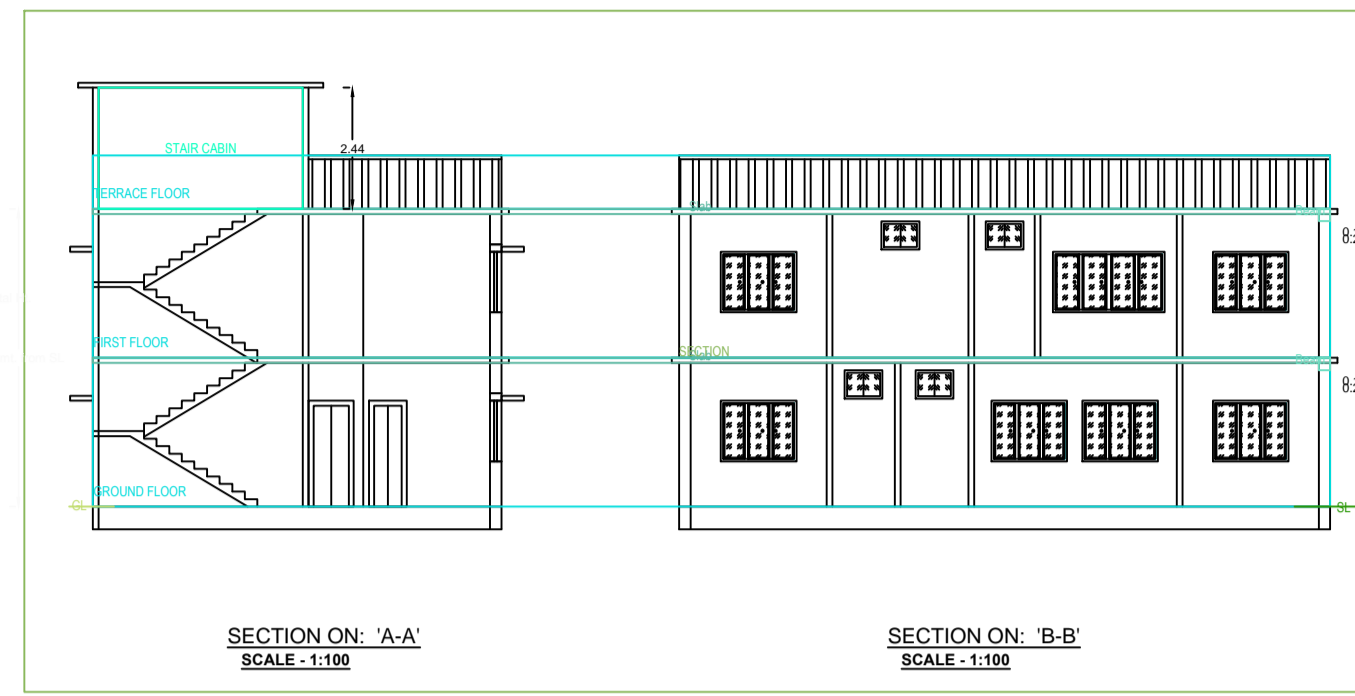
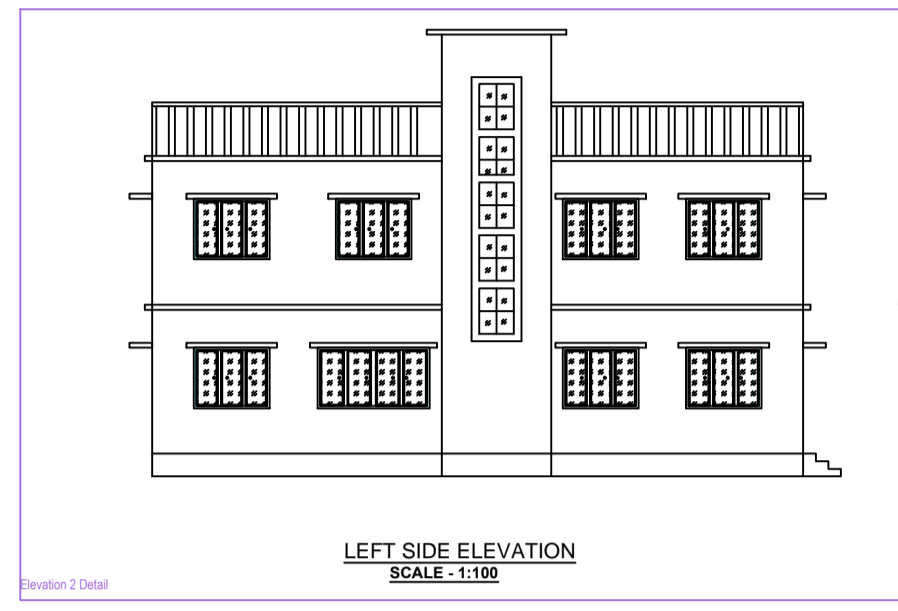
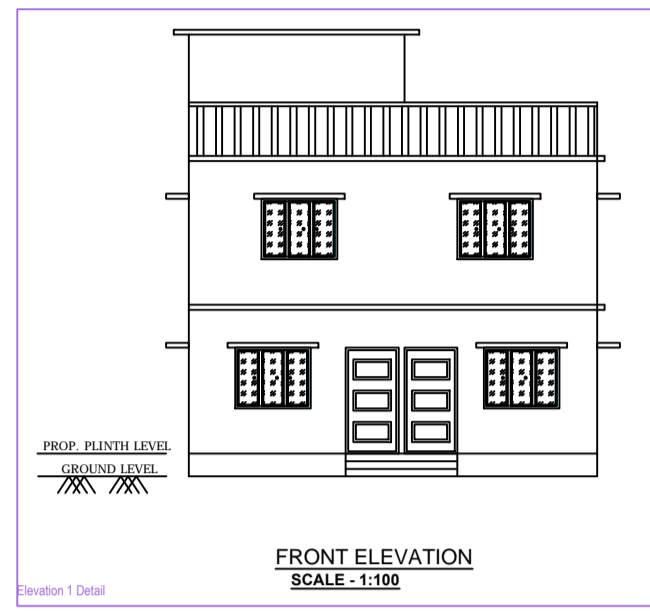

BRIEF SPECIFICATION

FOUNDATION :- R.C.C. (1:1.5:3) Column footing foundation.

PLINTH :- 304mm th R.C.C. (1:1.5:3) all round on plinth level.

FLOORING :- 40mmth Marble. flooring over 3"th P.C.C. (1:3:6).

SUPER STRUCTURE :- First class brick work in cement mortar (1:5).

SLAB, BEAM & LINTEL :- All R.C.C. work (1:1.5:3).

WOOD WORK :- All doors & windows frames of Sal wood

PLASTERING :- 12mm cement plaster (1:6) both side.

SCHEDULE

D - 1.067X2.134	W - 1.524X1.219
D1 - 0.914X2.134	W1 - 1.219X1.219
	V - 0.914X0.610

DETAILS OF AREA

1) LAND AREA (AS DEED) :-	167.28 Sq.M
2) LAND AREA (AS PER SITE) :-	164.42 Sq.M
3) GROUND FLOOR AREA :-	107.89 Sq.M
4) FIRST FLOOR AREA :-	107.89 Sq.M
5) COVERED AREA :-	215.78 Sq.ft.
6) % OF PLINTH AREA :-	65.61%
7) F.A.R. :-	1.31

TITLE OF DRAWING

PROPOSED RESIDENTIAL BUILDING PLAN OF SMT USHA GUPTA W/O SRI TRIPURARI PRASAD GUPTA ON PLOT NO.-OLD- 488 NEW-859, KHATA NO.-OLD-29, NEW-307 IN MOUZA- BISHUNPUR, MOUZA NO.05 IN DISTRICT OF DHANBAD (JHARKHAND)

SIG. OF OWNER

SIG. OF ENGINEER

AREA STATEMENT: DHANBAD MUNICIPAL CORPORATION

PROJECT DETAILS:

Version No. :-	Version No. 1.0/37
Version Date :-	Version Date: 16/10/2020
Project Name :-	Plot Use: Residential
Region :- JHARKHAND URBAN LOCAL BODIES	Plot Subtype: Bungalow/ Dwelling / Non Apartment
District: DHANBAD	Land Use Zone: NA
Application Type: General Proposal	Abutting Road Width :-
Project Type: Building Permission	Plot No. :-
Nature of Development: New	Reference Survey No./Survey No. :-
Location: Old Area	Thana No. :-
Sub Location: NA	Holding No. :-
Muza/Moza Name :-	Khata No. :-
Ward No. :-	North :-
Road/Street :-	South :-
	East :-
	West :-

AREA DETAILS:

AREA OF PLOT (Minimum)	(A)	SQ.MT	164.42
Net Plot Area (Gross Plot Area - Deduction from Gross Plot area)	(A-Deductions)		164.42
Deductions for Balance Plot Area (from Gross Plot Area)			14.60
COP Area			14.60
Total			149.81
Balance Plot Area (Net Plot Area - Recreational/Amenity space)	(A-Deductions)		164.42
Plot Area for Coverage (Net Plot Area)	(A-Deductions)		164.42
Plot Area for FSI (Net Plot Area + Road/Watering Area)	(A-Deductions)		164.42

COVERAGE CHECK

Proposed Coverage Area (65.65 %)	107.89
Total Coverage Area (65.62 %)	107.89

FAR CHECK

Proposed Area of FAR	215.78
Total Area of FAR	215.78

COLOR INDEX

Plot Boundary	Black
Abutting Road	Green
Proposed work (Coverage Area)	Red
Existing (To be retained)	Blue
Existing (To be demolished)	Yellow

MARGIN DETAIL:

Building / Wing Name	Road Name	Front Margin	Rear Margin	Side Margin	Side Margin
A (A)	4.87 mt. Wide Main Road	2.75	1.90	0.91	0.00

FAR & Tenement Details (Table 4c-1)

Building	No. of Same Bldg	Total Built Up Area (Sq.mt)	Proposed FAR Area (Sq.mt)	Total FAR Area (Sq.mt)	Tenent (No.)
A (A)	1	215.78	215.78	215.78	01
Grand Total:	1	215.78	215.78	215.78	01

Building A (A)

Floor Name	Total Built Up Area (Sq.mt)	Proposed FAR Area (Sq.mt)	Total FAR Area (Sq.mt)	Tenent (No.)
Ground Floor	107.89	107.89	107.89	01
First Floor	107.89	107.89	107.89	00
Terrace Floor	-	-	-	01
Total Number of Same Buildings	1	215.78	215.78	01
Total:	215.78	215.78	215.78	01

SCHEDULE OF JOINERY:

BUILDING NAME	NAME	LENGTH	HEIGHT	NOS
A (A)	D	0.76	2.10	04
A (A)	D	0.91	2.10	12
A (A)	D	1.07	2.10	02
A (A)	D	1.10	2.10	01
Total	-	-	-	19

SCHEDULE OF JOINERY:

BUILDING NAME	NAME	LENGTH	HEIGHT	NOS
A (A)	V	0.76	1.00	04
A (A)	W	1.52	1.20	20
A (A)	W	1.97	1.20	01
A (A)	W	2.25	1.20	02
Total	-	-	-	27

UnitBUA Table for Building A (A)

FLOOR	Name	UnitBUA Type	UnitBUA Area	Carpet Area	No. of Rooms	No. of Tenement
GROUND FLOOR PLAN	SPLIT A	FLAT	215.78	215.74	4	1
Total	-	-	215.78	215.74	18	1