

Proposal Basic Information

Proposal File No.	DMC/B/0109/W23/2024
Owner Name	SMT SHANTI DEVI
Khata No	37(OLD), 16(NEW)
Plot No	580(OLD), 370(NEW)
Village Name	Sabalpur
Use	Residential
SubUse	Bungalow/ Dwelling / Non Apartment

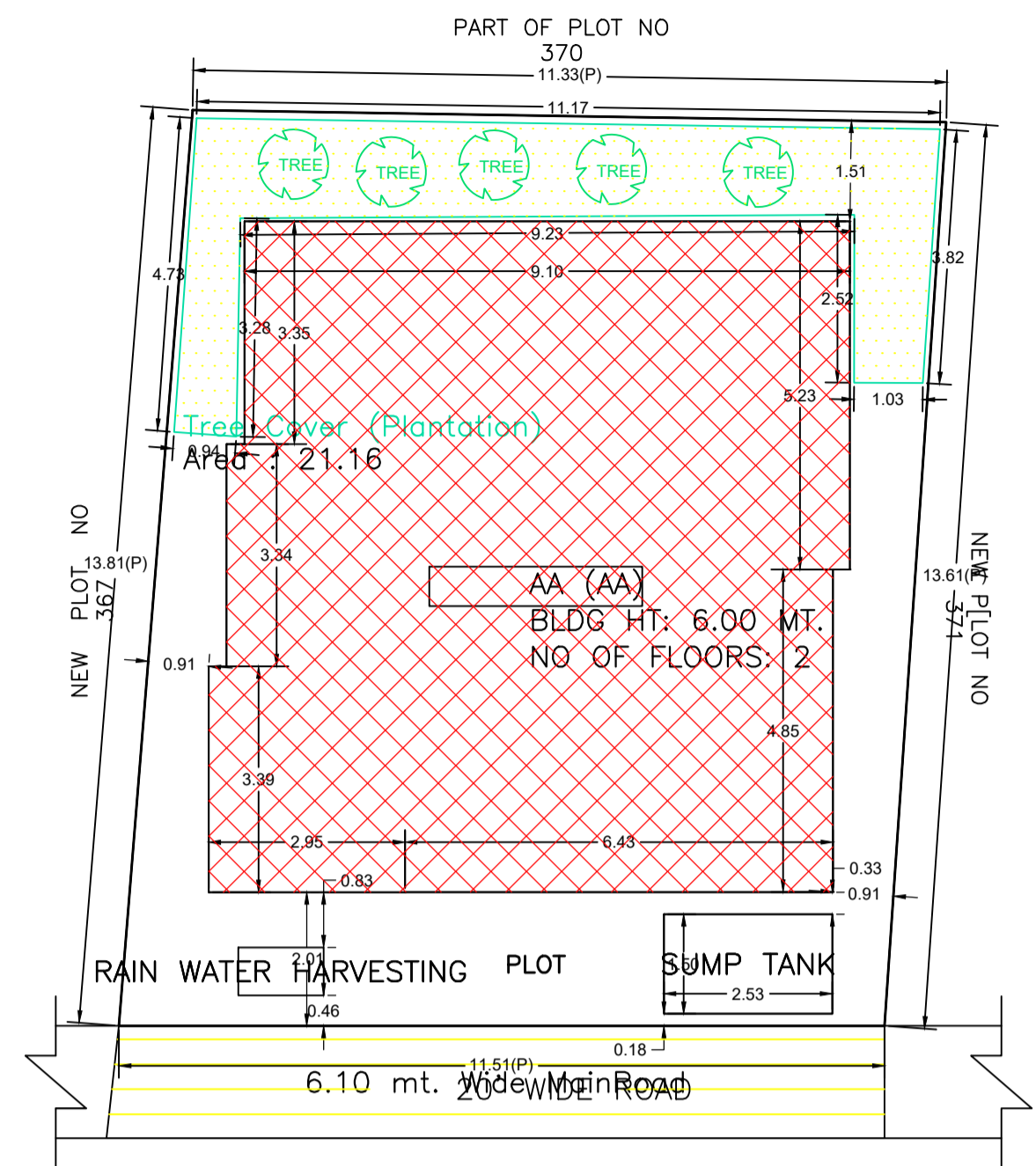

SITE PLAN

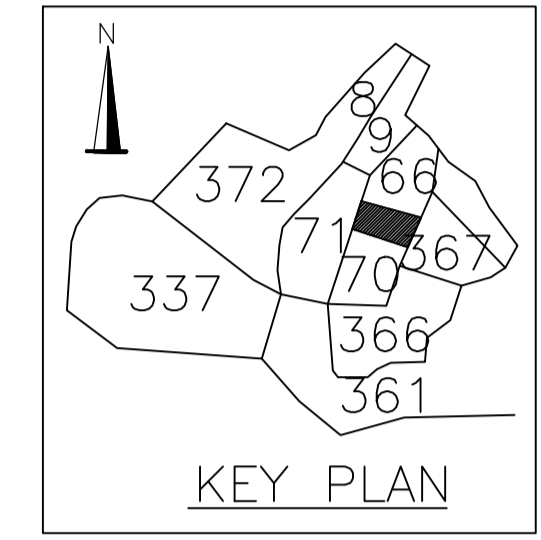

KEY PLAN

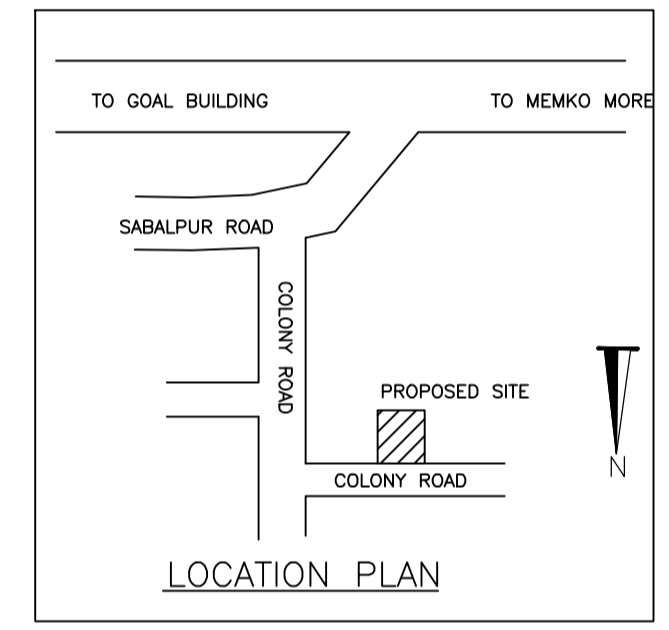

LOCATION PLAN

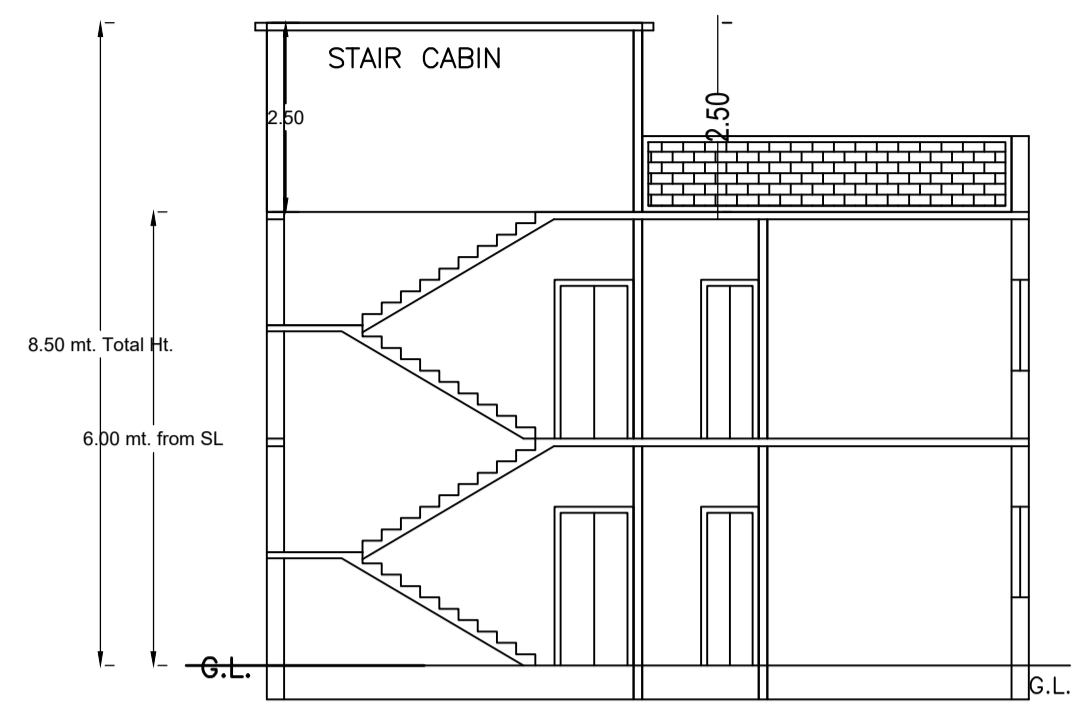

SECTION ON X-X

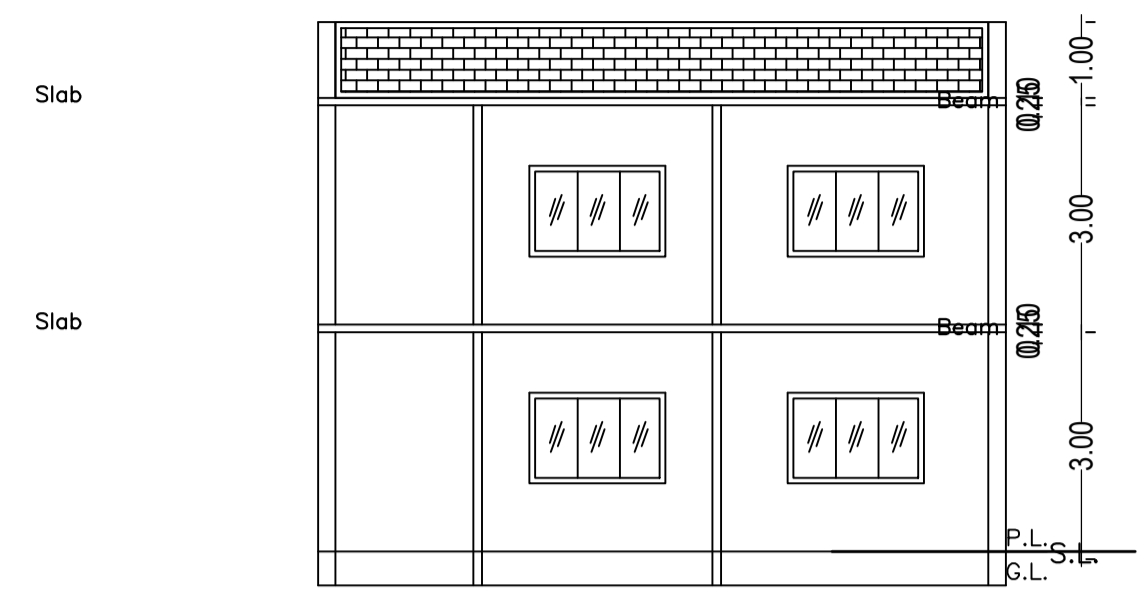

SECTION ON Y-Y

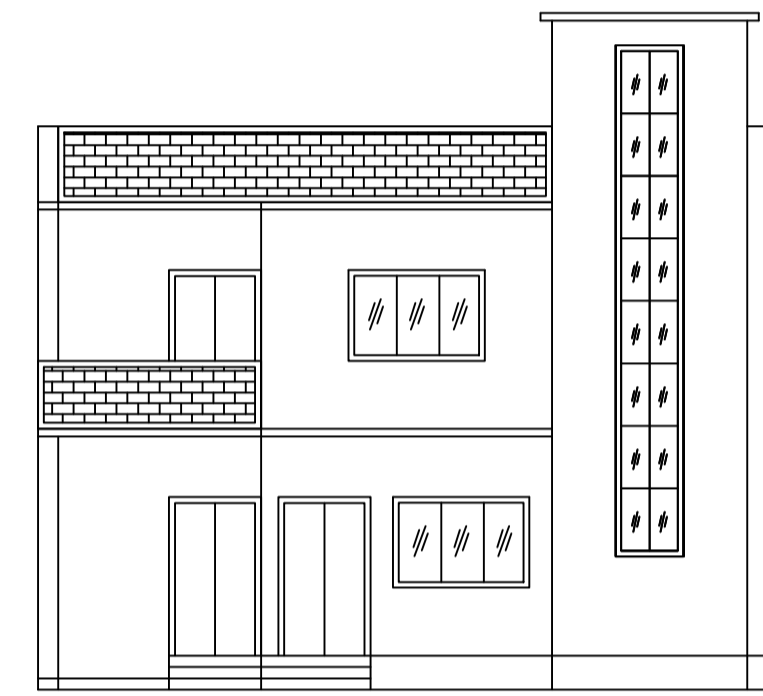

FRONT ELEVATION

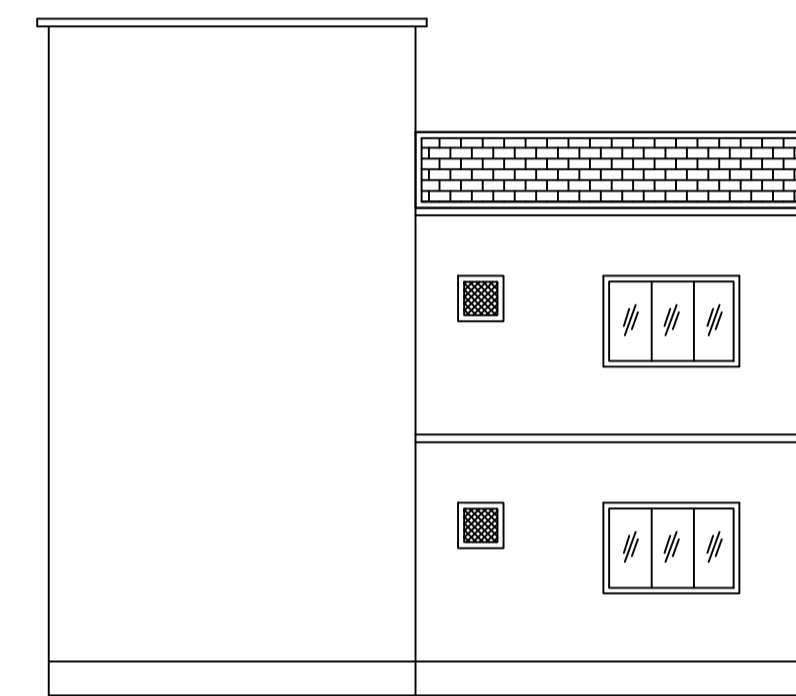

RIGHT SIDE ELEVATION

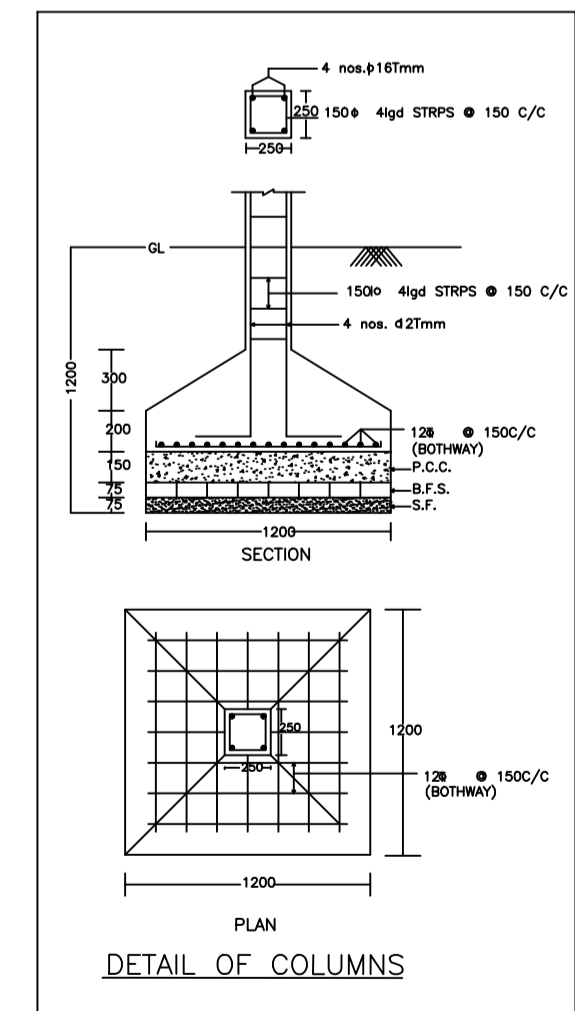

DETAIL OF COLUMNS

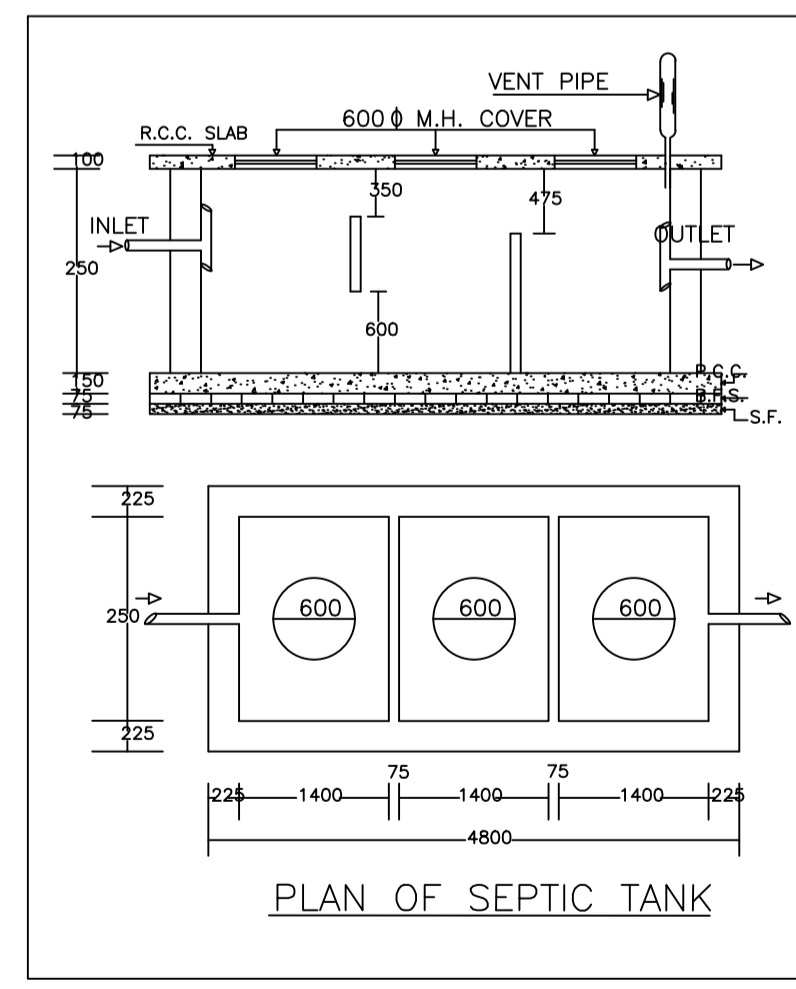

PLAN OF SEPTIC TANK

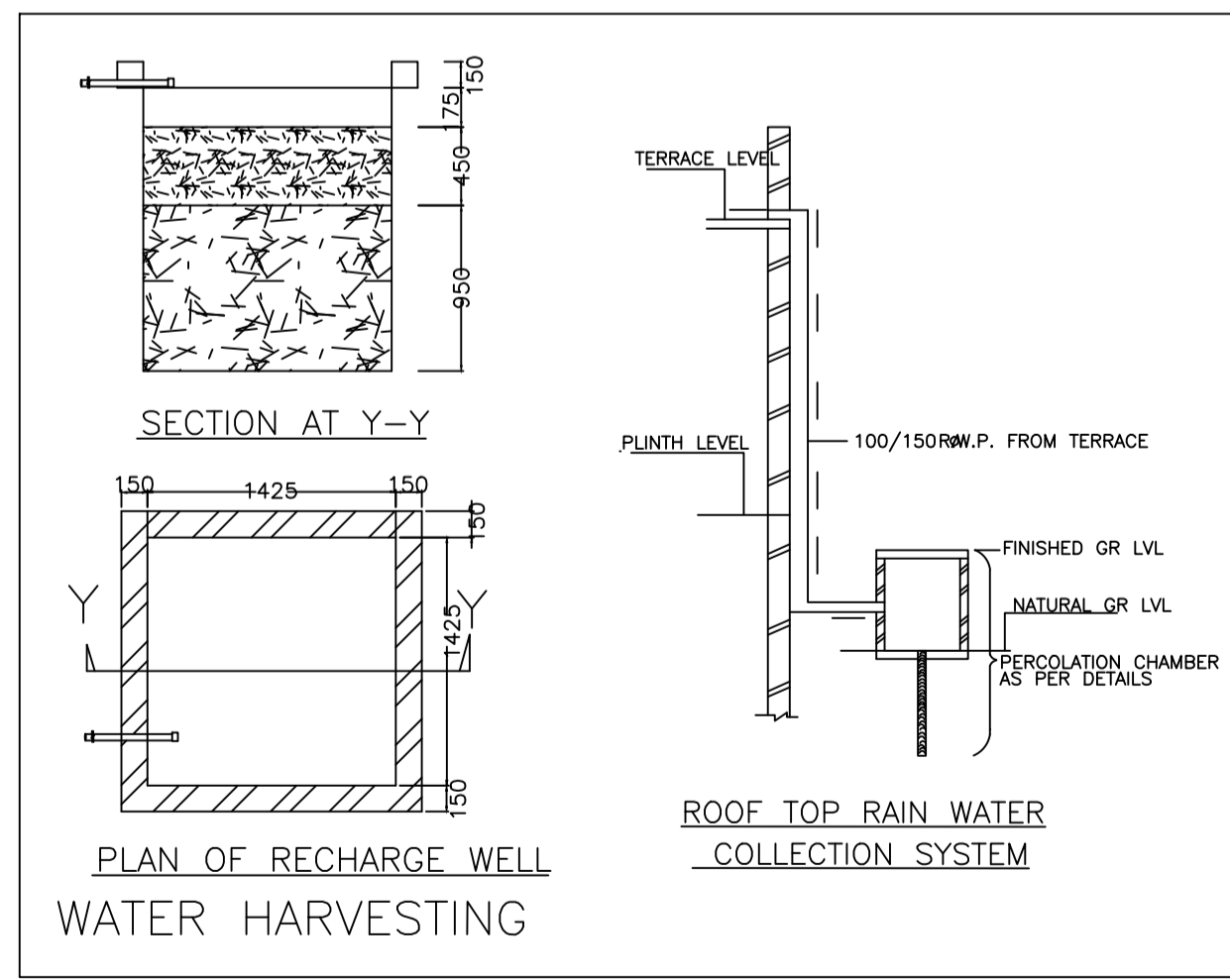

PLAN OF RECHARGE WELL WATER HARVESTING

UnitBUA Table for Building :AA (AA)

FLOOR	Name	UnitBUA Type	UnitBUA Area	Carpet Area	No. of Rooms	No. of Tenement
GROUND FLOOR PLAN	SPLIT AA	FLAT	177.03	176.54	6	1
FIRST FLOOR PLAN	SPLIT AA	FLAT	0.00	0.00	7	0
Total:			177.03	176.54	13	1

SCHEDULE OF DOOR:

BUILDING NAME	NAME	LENGTH	HEIGHT	NOS
AA (AA)	D3	0.76	2.10	02
AA (AA)	D1	0.91	2.10	02
AA (AA)	D1	0.93	2.10	02
AA (AA)	D2	0.99	2.10	02
AA (AA)	D1	1.07	2.10	04
AA (AA)	D1	1.22	2.10	01
AA (AA)	D	1.22	2.10	01

SCHEDULE OF WINDOW/VENTILATION:

BUILDING NAME	NAME	LENGTH	HEIGHT	NOS
AA (AA)	V	0.60	1.20	02
AA (AA)	W1	0.90	1.20	01
AA (AA)	W	1.80	1.20	14

Building :AA (AA)

Floor Name	Total Built Up Area (Sq.mt.)	Deductions (Area in Sq.mt.)		Proposed FAR Area (Sq.mt.)	Total FAR Area (Sq.mt.)	Total Consumed Additional FAR Area (Sq.mt.)	Trmt (No.)
		Parking	Resi.				
Ground Floor	93.21	9.41	83.80	83.80	83.80	83.80	01
First Floor	93.22	0.00	93.22	93.22	93.22	93.22	00
Terrace Floor	0.00	0.00	0.00	0.00	0.00	0.00	00
Total :	186.43	9.41	177.02	177.02	177.02	177.02	01
Total Number of Same Buildings :	1						
Total :	186.43	9.41	177.02	177.02	177.02	177.02	01

AREA STATEMENT		VERSION NO.:	1.0.69
DHANBAD MUNICIPAL CORPORATION		VERSION DATE:	16/10/2020
Region: JHARKHAND URBAN LOCAL BODIES	Plot Use: Residential		
District: DHANBAD	Plot SubUse: Bungalow/ Dwelling / Non Apartment		
Authority: DHANBAD MUNICIPAL CORPORATION	PlotNearbyReligiousStructure: NA		
Inward No: DMC/BP/0109/W23/2024	Plot/SubPlot No: 580(OLD), 370(NEW)		
Application Type: General Proposal	North Road Width - 6.10 WIDE ROAD		
Project Type: Building Permission	South: Plot No. - PART OF PLOT NO - 370		
Nature of Development: New	East: Plot No. - NEW PLOT NO-367		
Location of Development Area: Old Area	West: Plot No. - NEW PLOT NO-371		
AREA DETAILS:		SQ.MT.	
AREA OF PLOT (Minimum)	(A)	156.19	
NET AREA OF PLOT(Gross Plot Area - Deduction from Gross Plot area)	(A-Deductions)	156.19	
Deduction for Balance Plot Area(from Gross Plot Area)			
Common Plot		21.16	
Total		21.16	
BALANCE AREA OF PLOT(Net Plot Area - Recreational/Amenity space)	(A-Deductions)	135.03	
PLOT AREA FOR COVERAGE(Net Plot Area)	(A-Deductions)	156.19	
Plot Area for FAR (Net Plot Area + RoadWidening Area)	(A-Deductions)	156.19	
COVERAGE CHECK			
Permissible Coverage area (70.00 %)		109.33	
Proposed Coverage Area (59.67 %)		93.20	
Total Prop. Coverage Area (59.67 %)		93.20	
Balance coverage area (10.33 %)		16.13	
FAR CHECK			
Perm. FAR Area (2.500)		390.48	
Total Perm. FAR area		390.48	
Residential FAR		177.02	
Proposed FAR Area		177.02	
Total Proposed FAR Area		177.02	
Consumed FAR (Factor)		1.13	
Balance FAR Area		213.46	
BUILT UP AREA CHECK			
Total Proposed BuiltUp Area		186.43	
ARCHITECT (Regd)	Jyoti Mishra		
ENGINEER (Regd)			
SUPERVISOR (Regd)			
OWNER (Regd)	SMT SHANTI DEVI		
DEVELOPMENT AUTHORITY		LOCAL BODY	

COLOR INDEX	
PLOT BOUNDARY	[Red Line]
ABUTTING ROAD	[Green Line]
PROPOSED CONSTRUCTION	[Yellow Area]
COMMON PLOT	[Blue Area]
ROAD WIDENING AREA	[Orange Area]
EXISTING (To be retained)	[Grey Area]
EXISTING (To be demolished)	[Black Area]

Buildingwise Floor FAR Details

Floor Name	Building Name		Total	
	Proposed Built Up Area (Sq.mt.)	Proposed FAR Area (Sq.mt.)	Total Proposed Built Up Area (Sq.mt.)	Total FAR Area (Sq.mt.)
Ground Floor	93.21	83.80	93.21	83.80
First Floor	93.22	93.22	93.22	93.22
Terrace Floor	0.00	0.00	0.00	0.00
Total :	186.43	177.02	186.43	177.02

Building USE/SUBUSE Details

Building Name	Building Use	Building SubUse	Building Structure
AA (AA)	Residential	Bungalow/ Dwelling / Non Apartment	Non-Highrise

FAR & Tenement Details (Table 4c-1)

Building	No. of Same Bldg	Total Built Up Area (Sq.mt.)	Deductions (Area in Sq.mt.)		Proposed FAR Area (Sq.mt.)	Total FAR Area (Sq.mt.)	Total Consumed Additional FAR Area (Sq.mt.)	Trmt (No.)
			Parking	Resi.				
AA (AA)	1	186.43	9.41	83.80	177.02	177.02	177.02	01
Grand Total :	1	186.43	9.41	83.80	177.02	177.02	177.02	01

LTP NAME AND SIGNATURE	STRUCTURAL ENG'S NAME AND SIGNATURE	BUILDER NAME AND SIGNATURE	DIGITAL SIGNATURE
Jyoti Mishra DMC/ARC/0013/2017			

Proposal Basic Information	
Proposal File No.	DMCB/P0109/W23/2024
Owner Name	SMT SHANTI DEVI
Khata No	37(OLD), 16(NEW)
Plot No	580(OLD), 370(NEW)
Village Name	Sabalpur
Use	Residential
SubUse	Bungalow/ Dwelling / Non Apartment

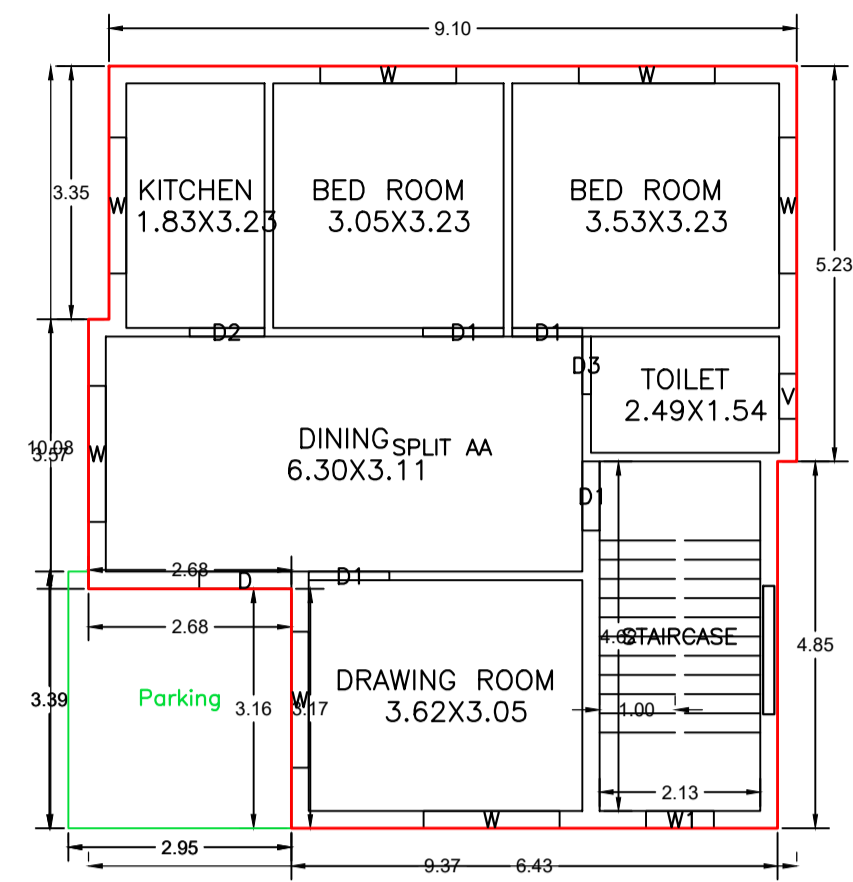

GROUND FLOOR PLAN
(Proposed)
(SCALE 1:100)

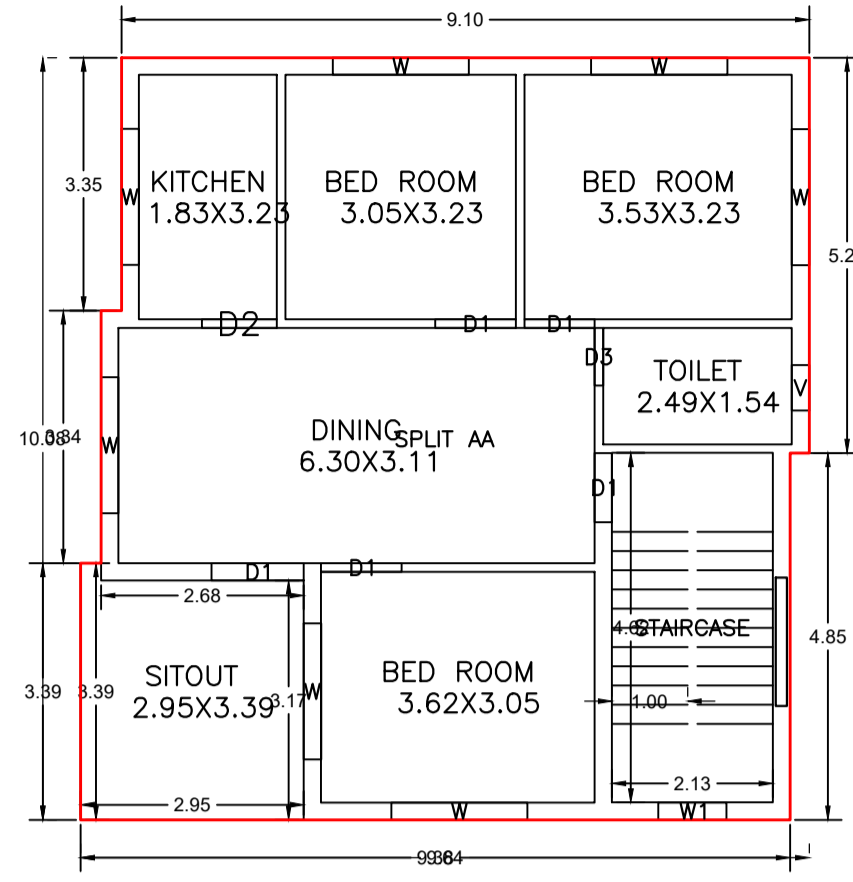

FIRST FLOOR PLAN
(Proposed)
(SCALE 1:100)

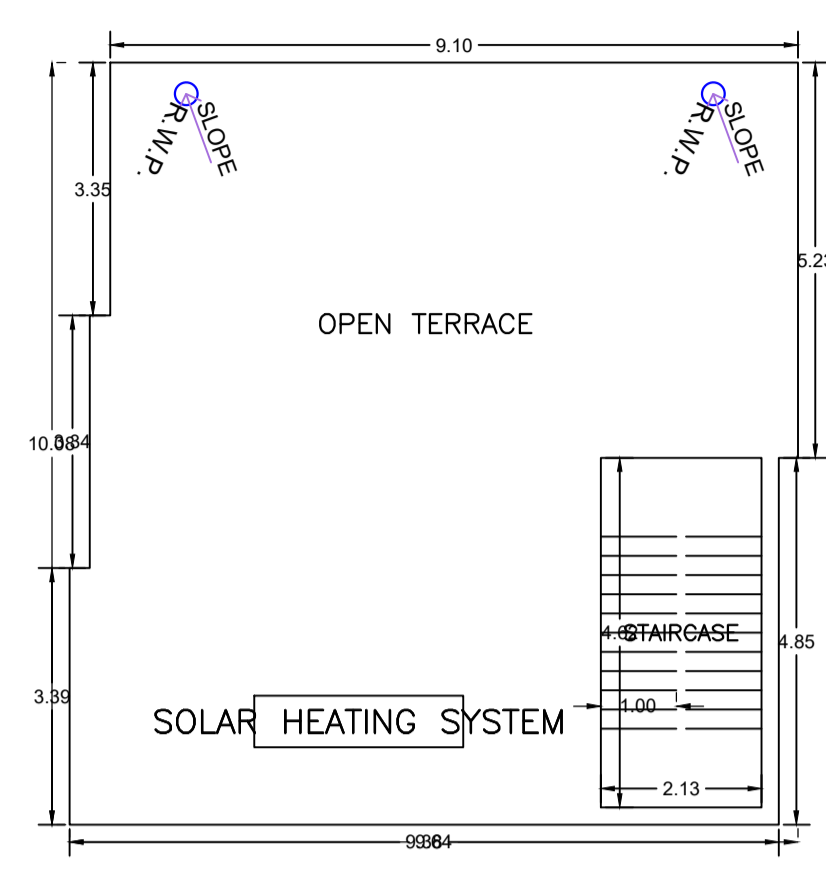

TERRACE FLOOR PLAN
(Proposed)
(SCALE 1:100)

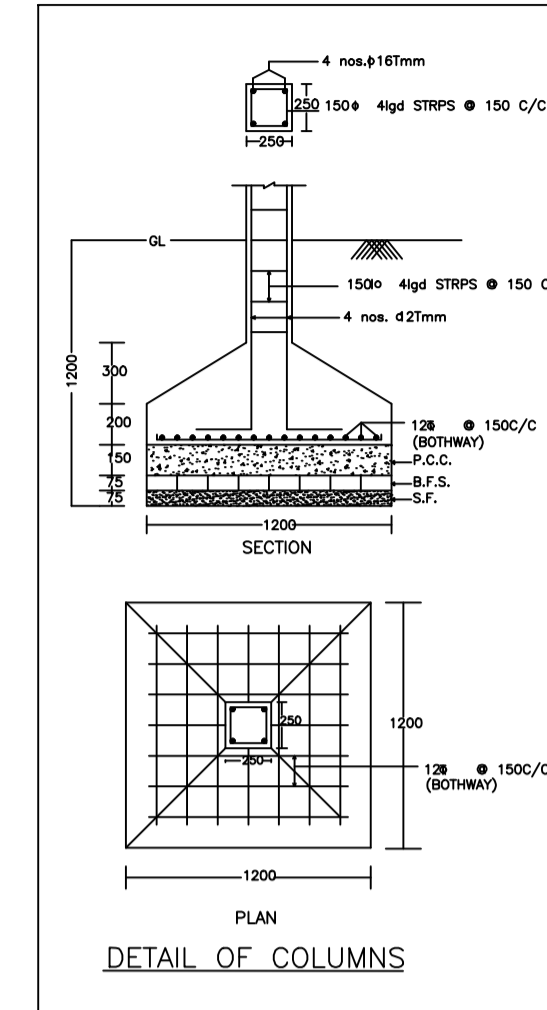

DETAIL OF COLUMNS

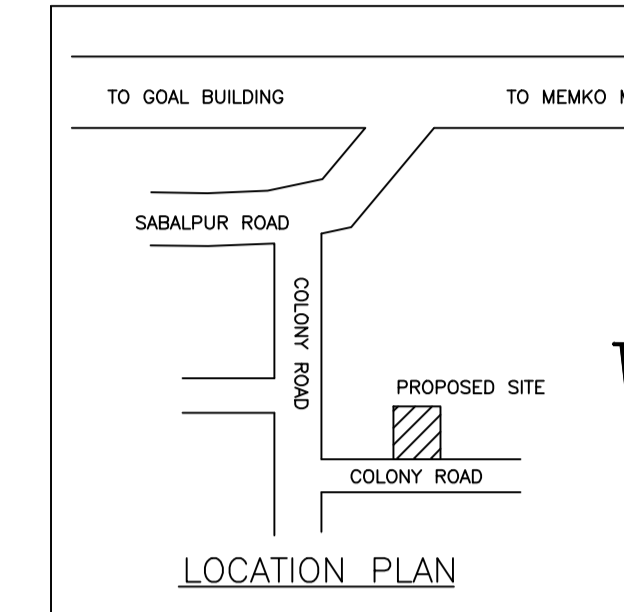

LOCATION PLAN

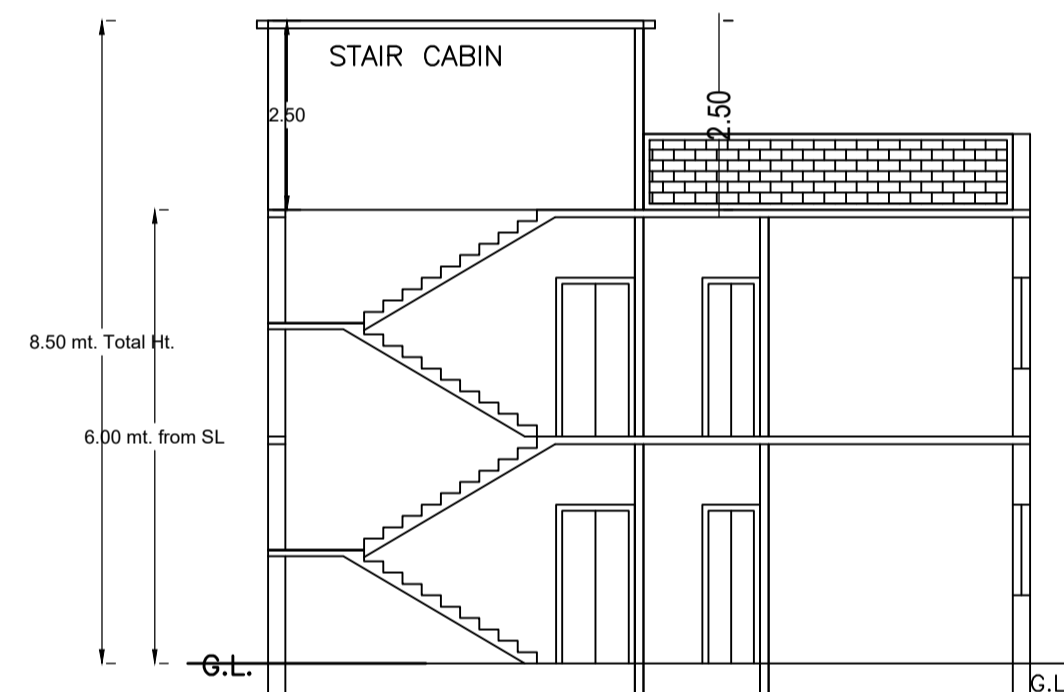

SECTION ON X-X

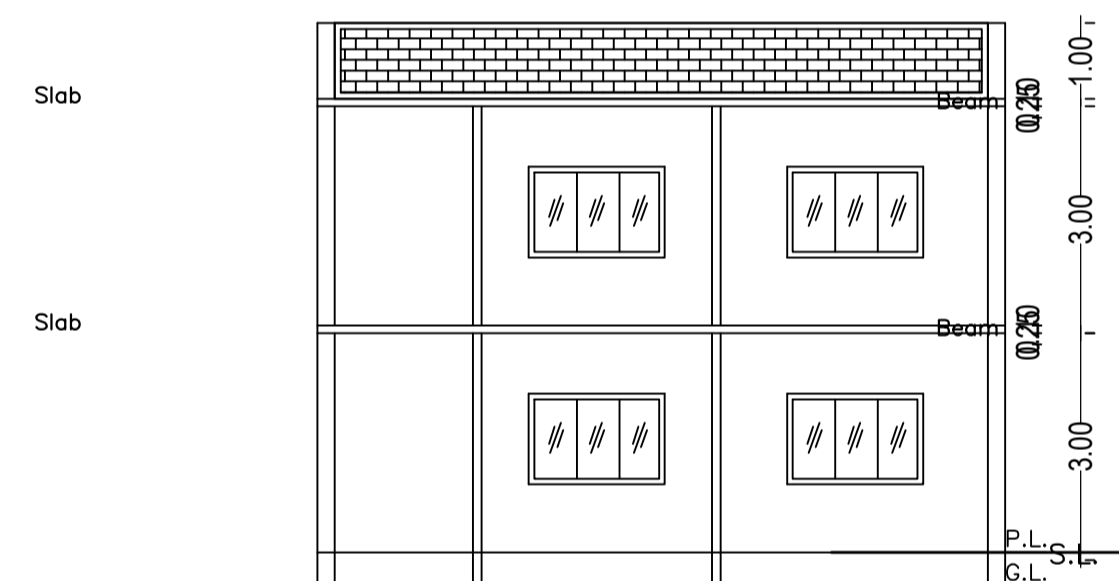

SECTION ON Y-Y

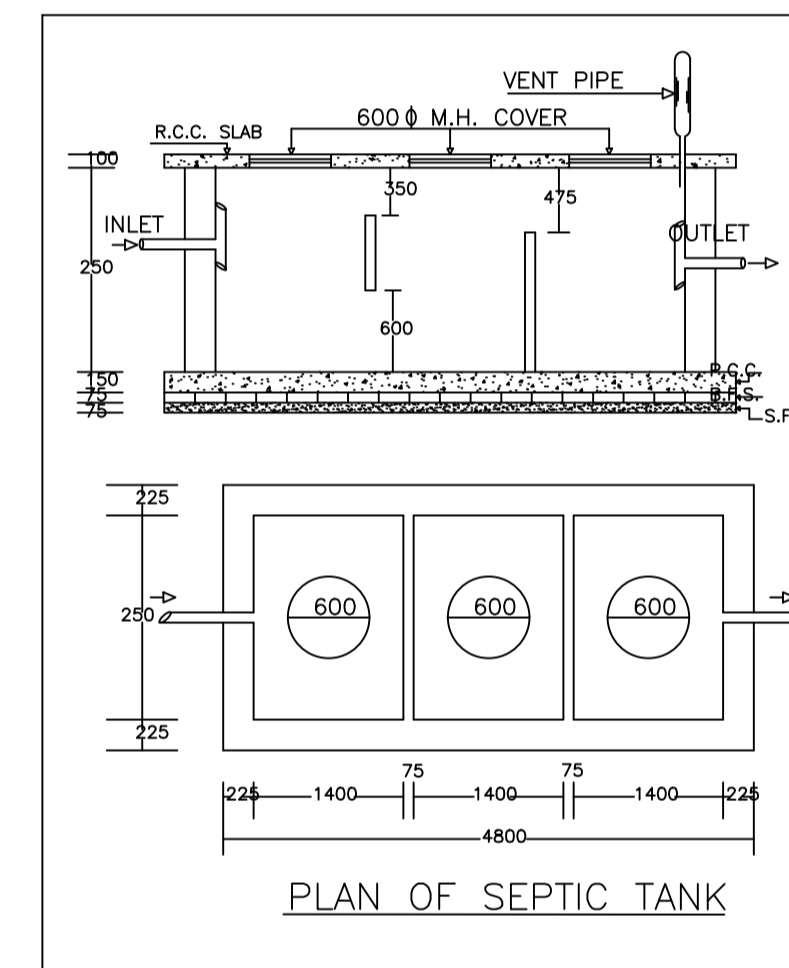

PLAN OF SEPTIC TANK

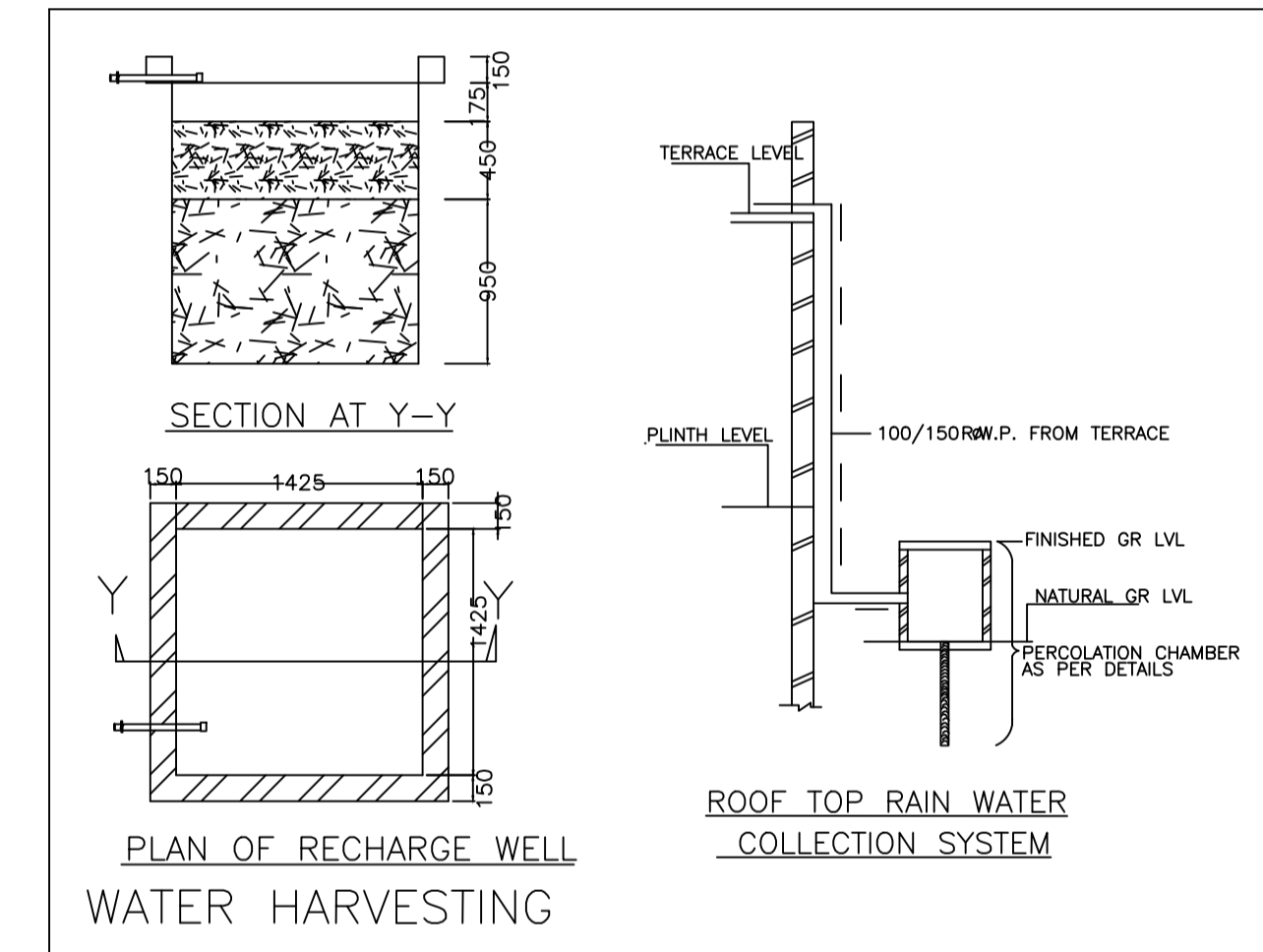

PLAN OF RECHARGE WELL
WATER HARVESTING

ROOF TOP RAIN WATER
COLLECTION SYSTEM

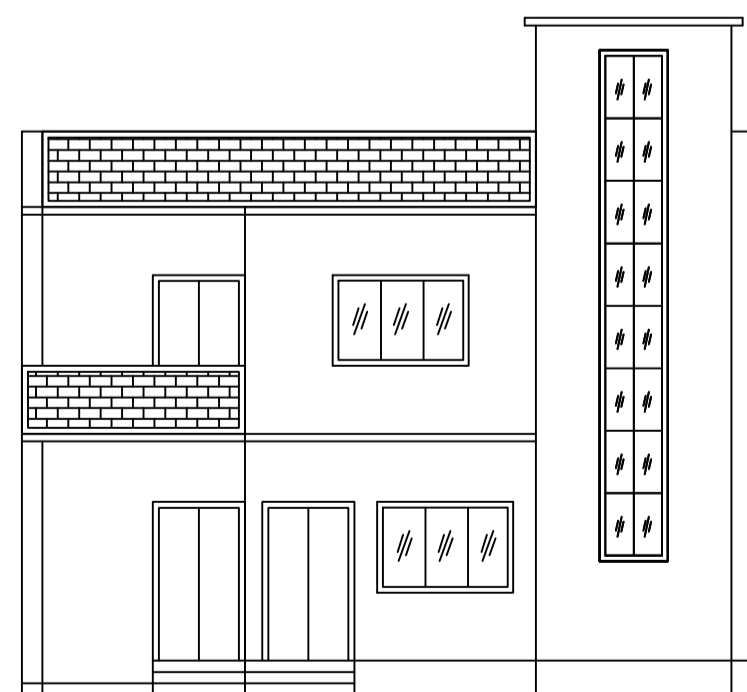

FRONT ELEVATION

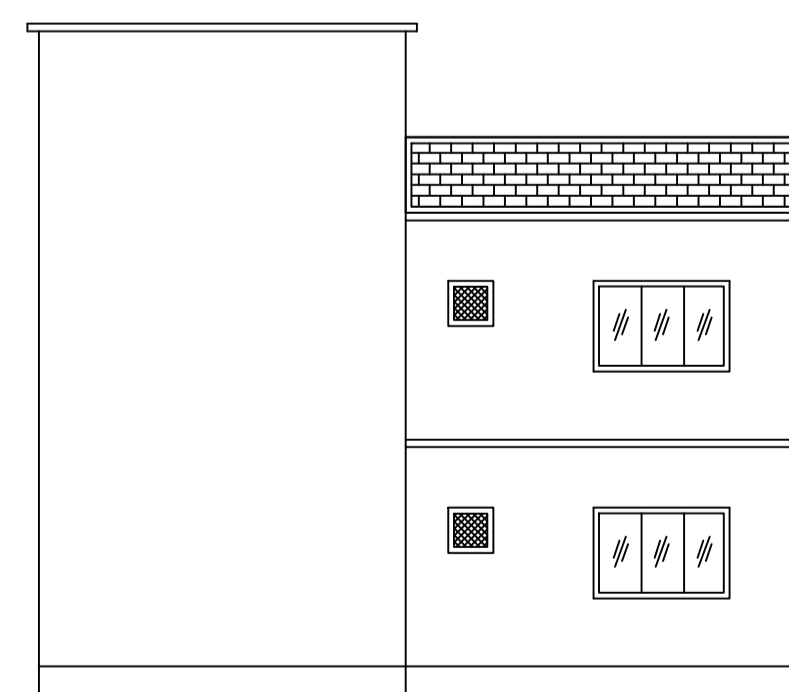

RIGHT SIDE ELEVATION

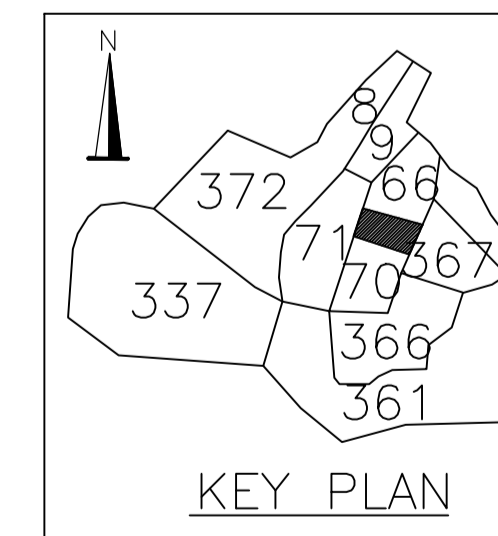

KEY PLAN

LTP NAME AND SIGNATURE	STRUCTURAL ENG'S NAME AND SIGNATURE	BUILDER NAME AND SIGNATURE	DIGITAL SIGNATURE
Jyoti Mishra DMC/ARC/0013/2017			