

Proposal Basic Information

Proposal File No.	DMC/BP/0284/W21/2024
Owner Name	SMT.RITA DEVI
Khata No	122
Plot No	4167
Village Name	Dhaiya
Use	Residential
SubUse	Bungalow/ Dwelling / Non Apartment

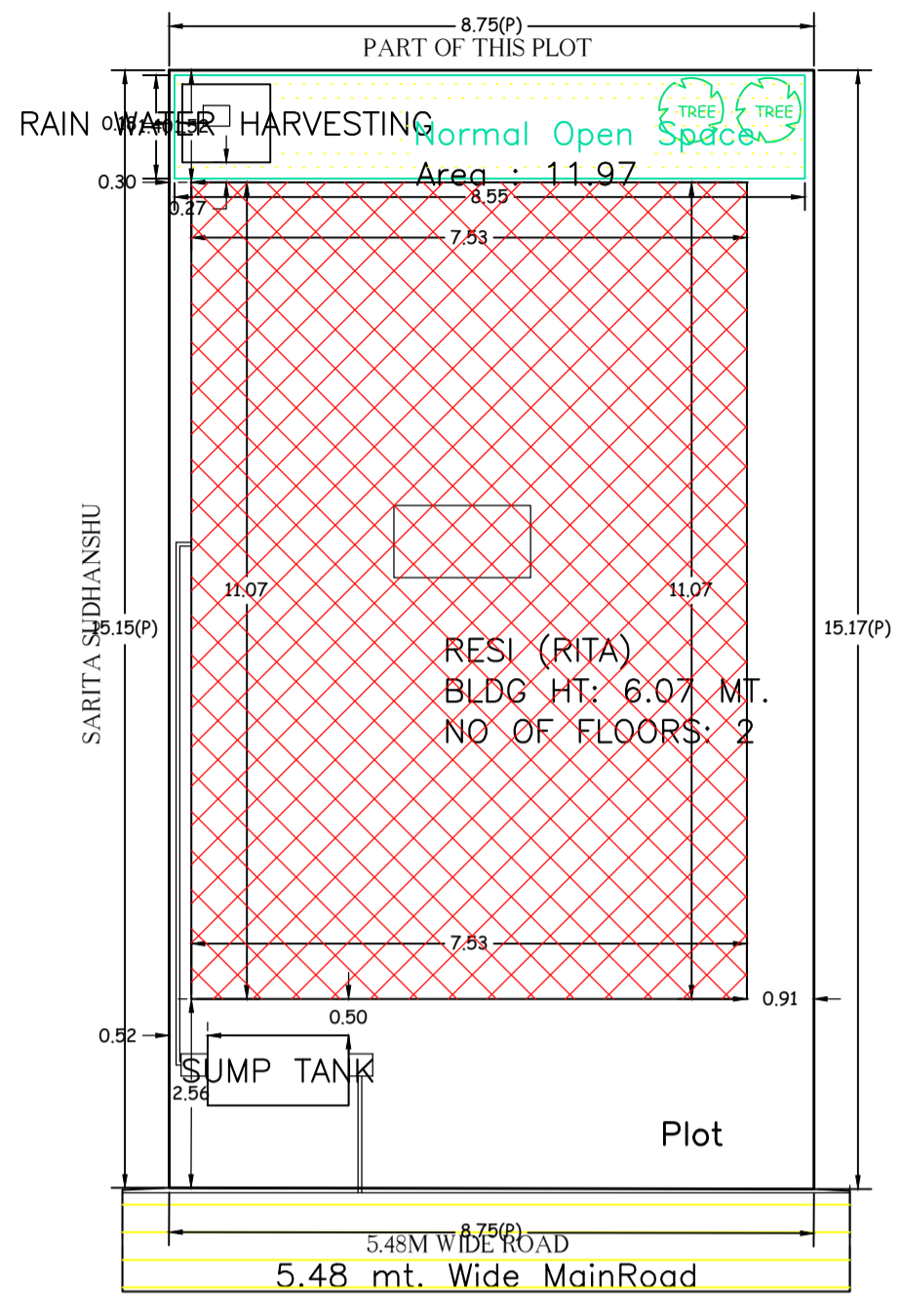

SITE PLAN

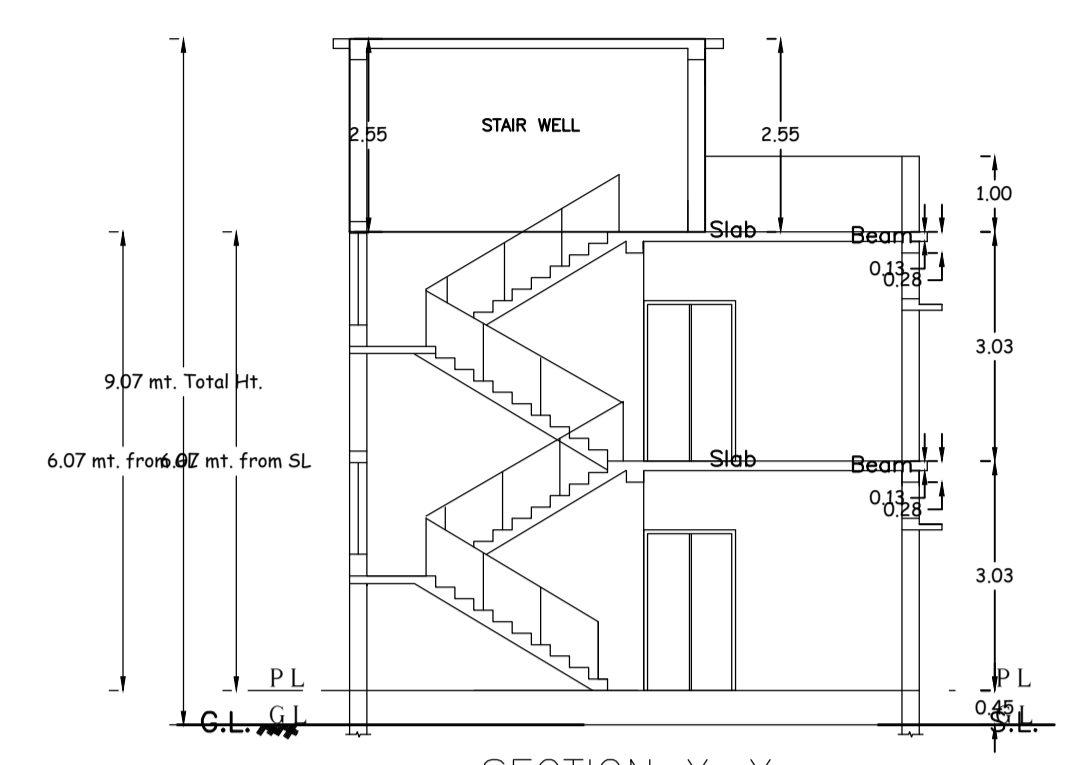

SECTION X-X

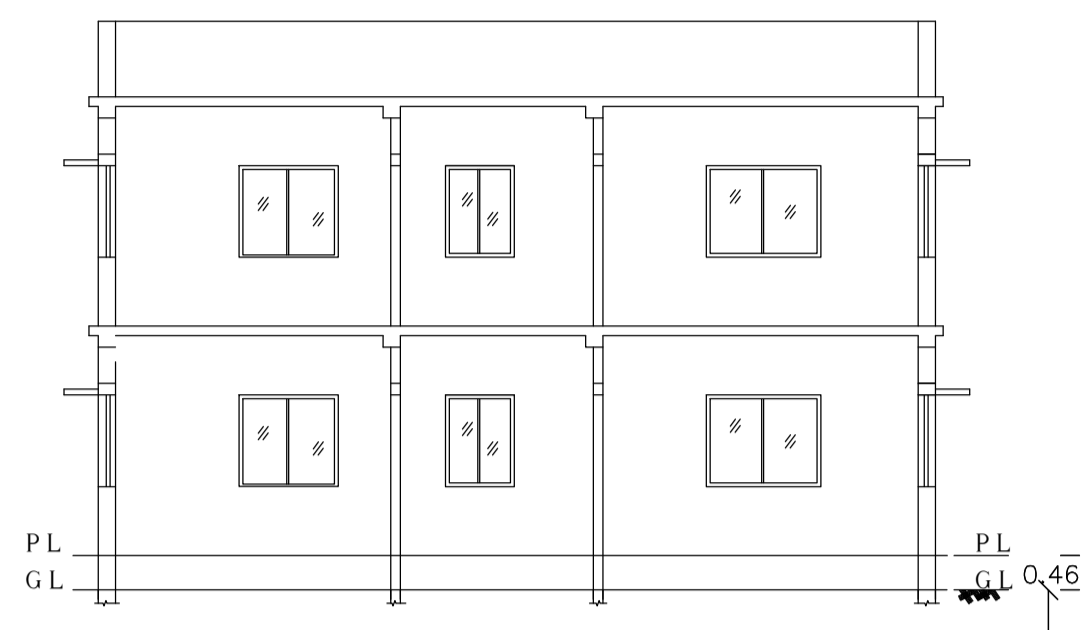

SECTION Y-Y

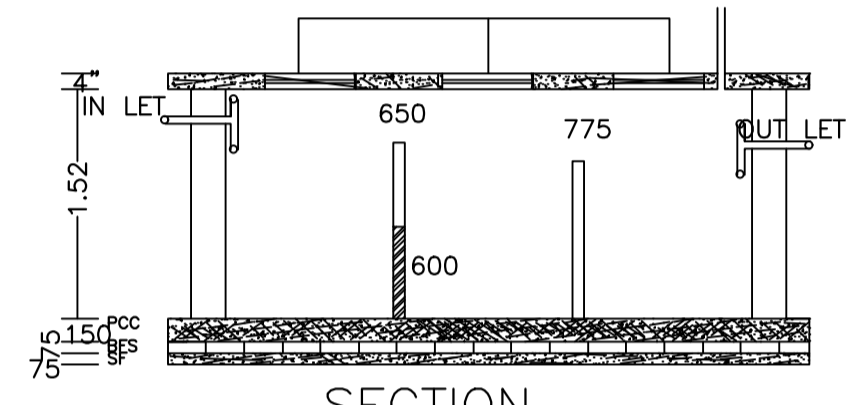

SECTION

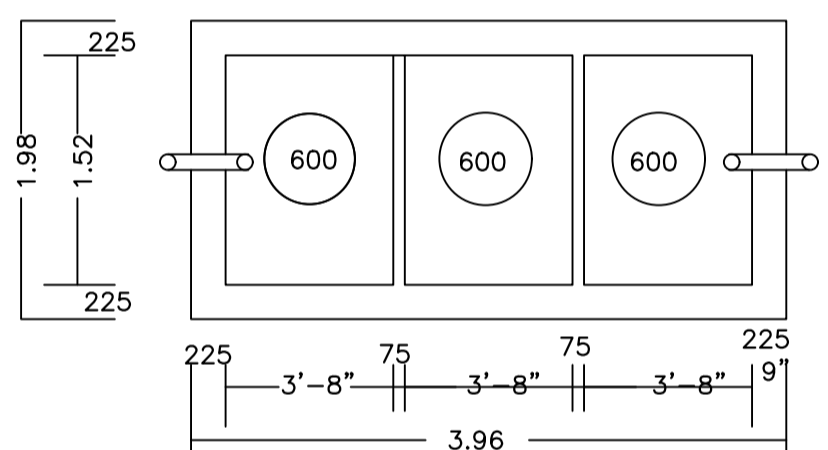

PLAN OF SEPTIC TANK

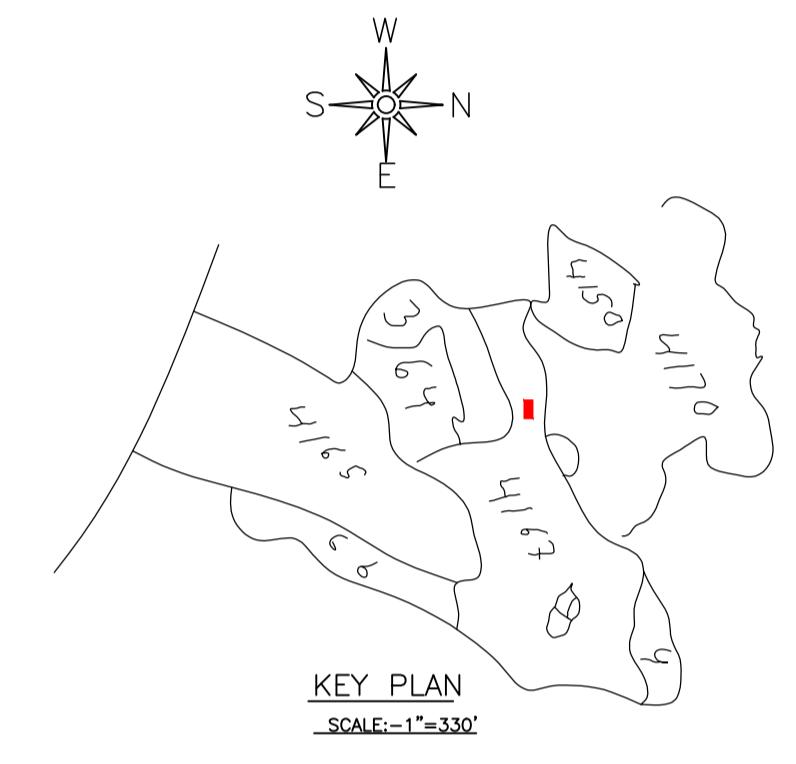

KEY PLAN

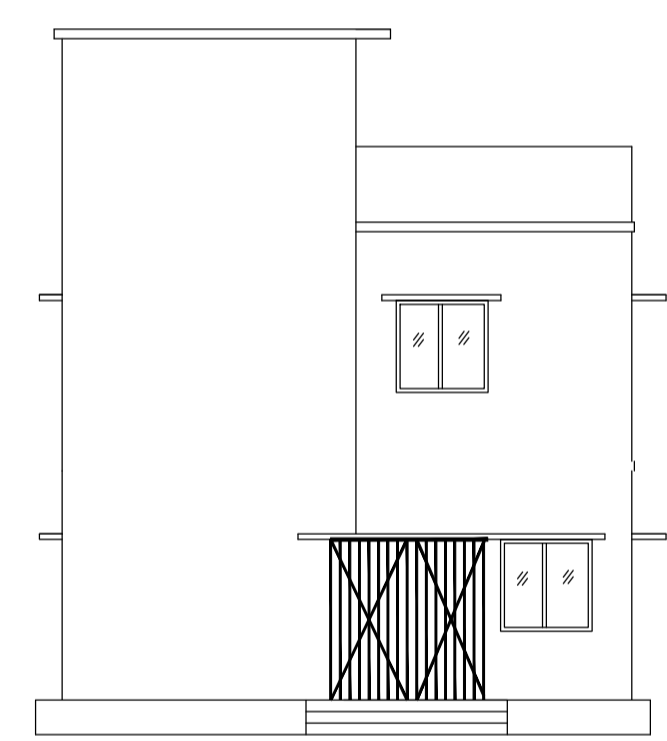

FRONT ELEVATION

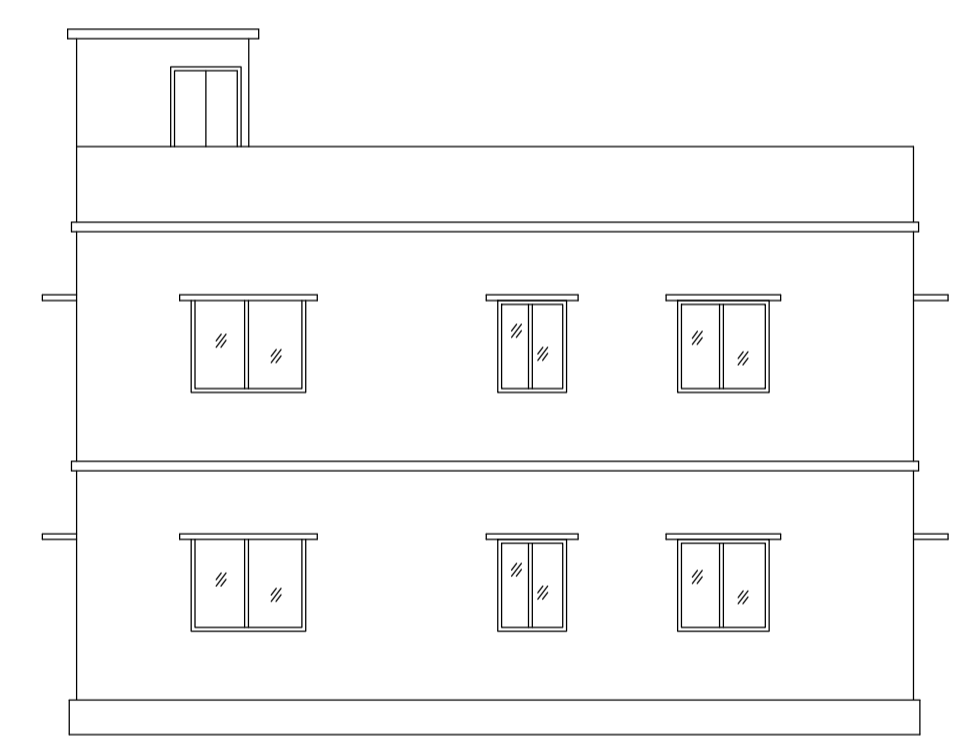

RIGHT SIDE ELEVATION

UnitBUA Table for Building :RESI (RITA)

FLOOR	Name	UnitBUA Type	UnitBUA Area	Carpet Area	No. of Rooms	No. of Tenement
GROUND FLOOR PLAN	SPLIT 1	FLAT	166.80	166.24	7	1
FIRST FLOOR PLAN	SPLIT 1	FLAT	0.00	0.00	7	0
Total:	-	-	166.80	166.24	14	1

SCHEDULE OF DOOR:

BUILDING NAME	NAME	LENGTH	HEIGHT	NOS
RESI (RITA)	D	0.73	2.10	04
RESI (RITA)	D	0.91	2.10	01
RESI (RITA)	D	0.92	2.10	01
RESI (RITA)	D	1.06	2.10	04
RESI (RITA)	D	1.07	2.10	02
RESI (RITA)	D	1.21	2.10	01

SCHEDULE OF WINDOW/VENTILATION:

BUILDING NAME	NAME	LENGTH	HEIGHT	NOS
RESI (RITA)	W	0.61	1.20	04
RESI (RITA)	W	0.91	1.20	02
RESI (RITA)	W	1.21	1.20	12
RESI (RITA)	W	1.52	1.20	02

Building :RESI (RITA)

Floor Name	Total Built Up Area (Sq.mt.)	Proposed FAR Area (Sq.mt.)	Total FAR Area (Sq.mt.)	Total Consumed Additional FAR Area (Sq.mt.)	Tnmt (No.)
Ground Floor	83.40	83.40	83.40	83.40	01
First Floor	83.40	83.40	83.40	83.40	00
Terrace Floor	0.00	0.00	0.00	0.00	00
Total:	166.80	166.80	166.80	166.80	01
Total Number of Same Buildings	1				
Total:	166.80	166.80	166.80	166.80	01

FAR & Tenement Details (Table 4c-1)

Building	No. of Same Bldg	Total Built Up Area (Sq.mt.)	Proposed FAR Area (Sq.mt.)	Total FAR Area (Sq.mt.)	Total Consumed Additional FAR Area (Sq.mt.)	Tnmt (No.)
RESI (RITA)	1	166.80	166.80	166.80	166.80	01
Grand Total :	1	166.80	166.80	166.80	166.80	01

LTP NAME AND SIGNATURE	STRUCTURAL ENG'S NAME AND SIGNATURE	BUILDER NAME AND SIGNATURE	DIGITAL SIGNATURE
DEEPAK KUMAR DMC/ARC/0004/2017			

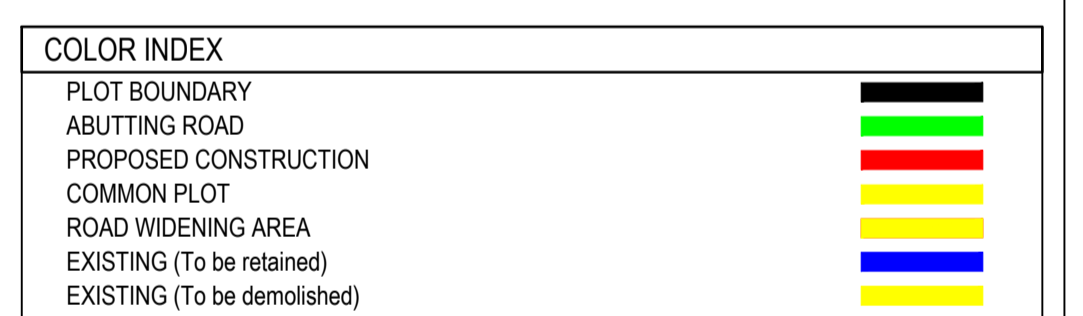

Buildingwise Floor FAR Details

Floor Name	Building Name		Total	
	Proposed Built Up Area (Sq.mt.)	Proposed FAR Area (Sq.mt.)	Total Proposed Built Up Area (Sq.mt.)	Total FAR Area (Sq.mt.)
Ground Floor	83.40	83.40	83.40	83.40
First Floor	83.40	83.40	83.40	83.40
Terrace Floor	0.00	0.00	0.00	0.00
Total :	166.80	166.80	166.80	166.80

Building USE/SUBUSE Details

Building Name	Building Use	Building SubUse	Building Structure	Floor Name	Floor Use	Floor SubUse	FAR Name	FAR Use	FAR SubUse
RESI (RITA)	Residential	Bungalow/ Dwelling / Non Apartment	Non-Highrise	GROUND FLOOR PLAN	Residential	Bungalow/ Dwelling / Non Apartment	Residential FAR	Residential	Bungalow/ Dwelling / Non Apartment
				FIRST FLOOR PLAN	Residential	Bungalow/ Dwelling / Non Apartment	Residential FAR	Residential	Bungalow/ Dwelling / Non Apartment
				TERRACE FLOOR PLAN	Residential	Bungalow/ Dwelling / Non Apartment	-	-	-

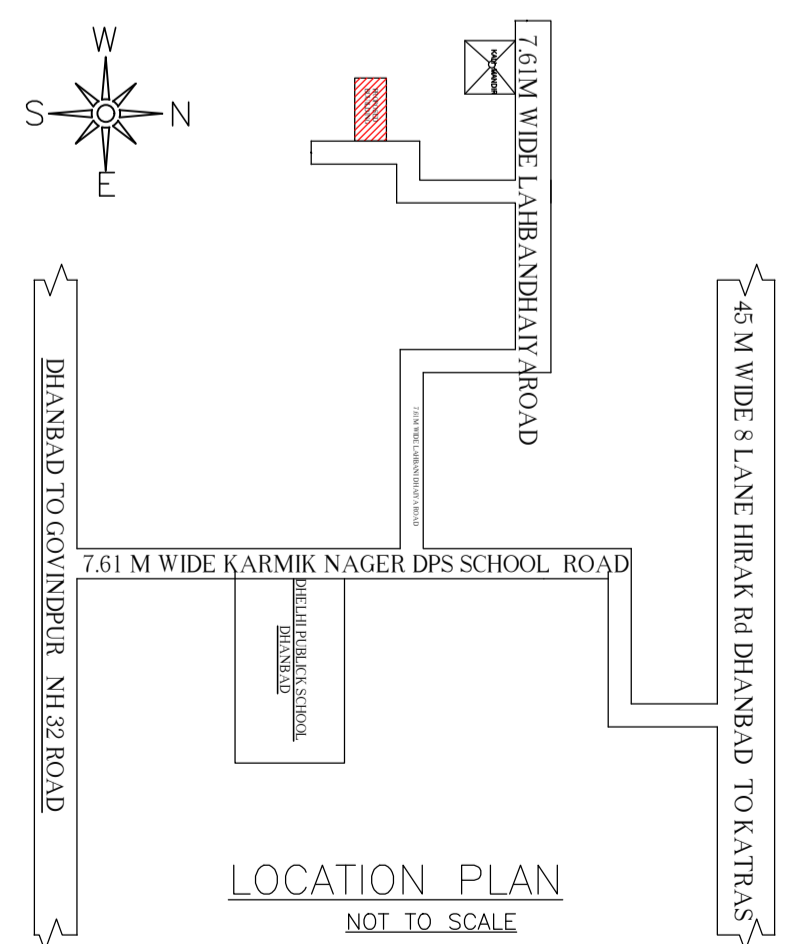

LOCATION PLAN

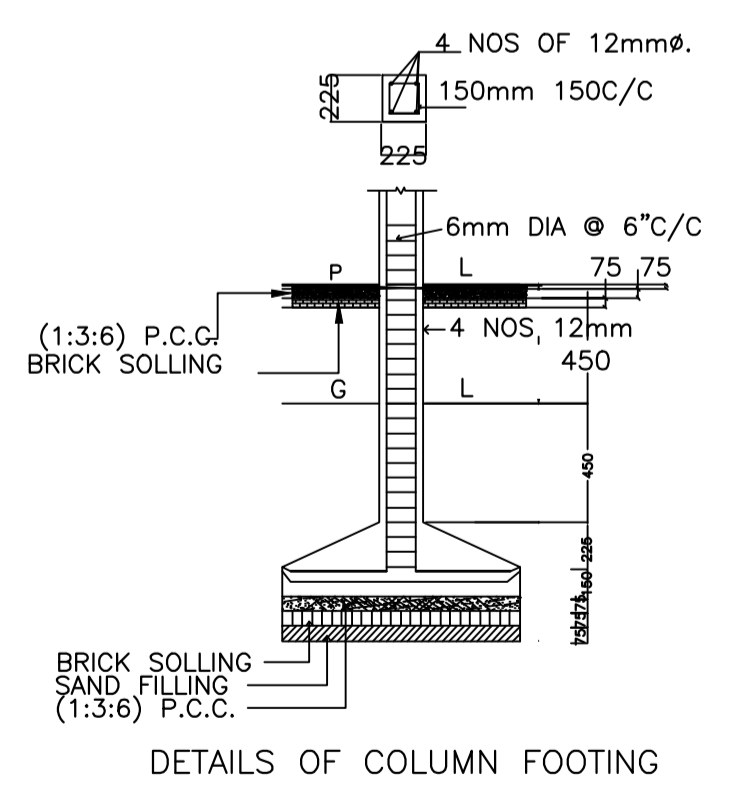

DETAILS OF COLUMN FOOTING

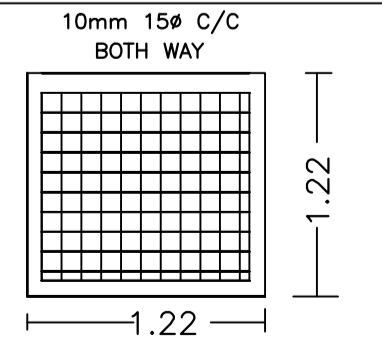

PLAN DETAILS OF COLUMNS (SCALE:- 1:50)

Proposal Basic Information	
Proposal File No.	DMC/BP/0284/W21/2024
Owner Name	SMT.RITA DEVI
Khata No	122
Plot No	4167
Village Name	Dhaiya
Use	Residential
SubUse	Bungalow/ Dwelling / Non Apartment

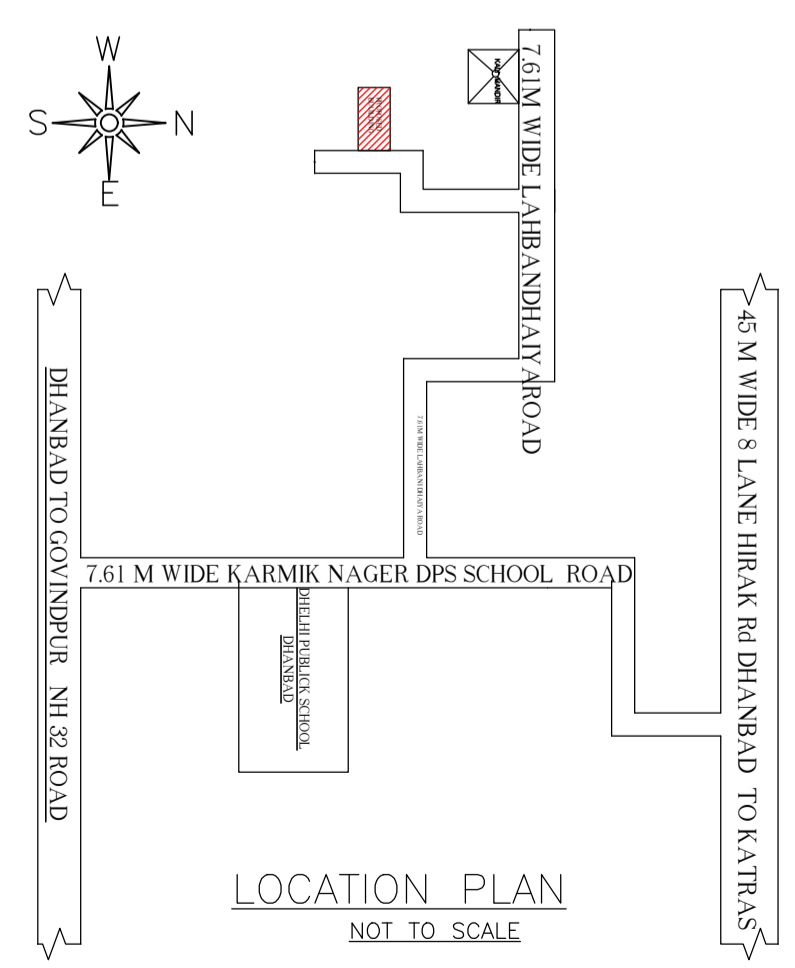
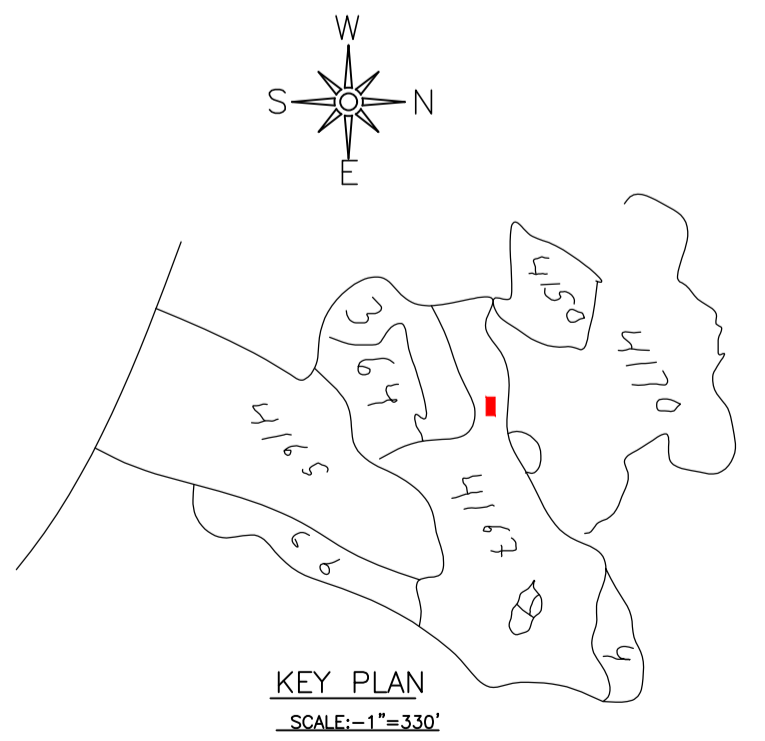
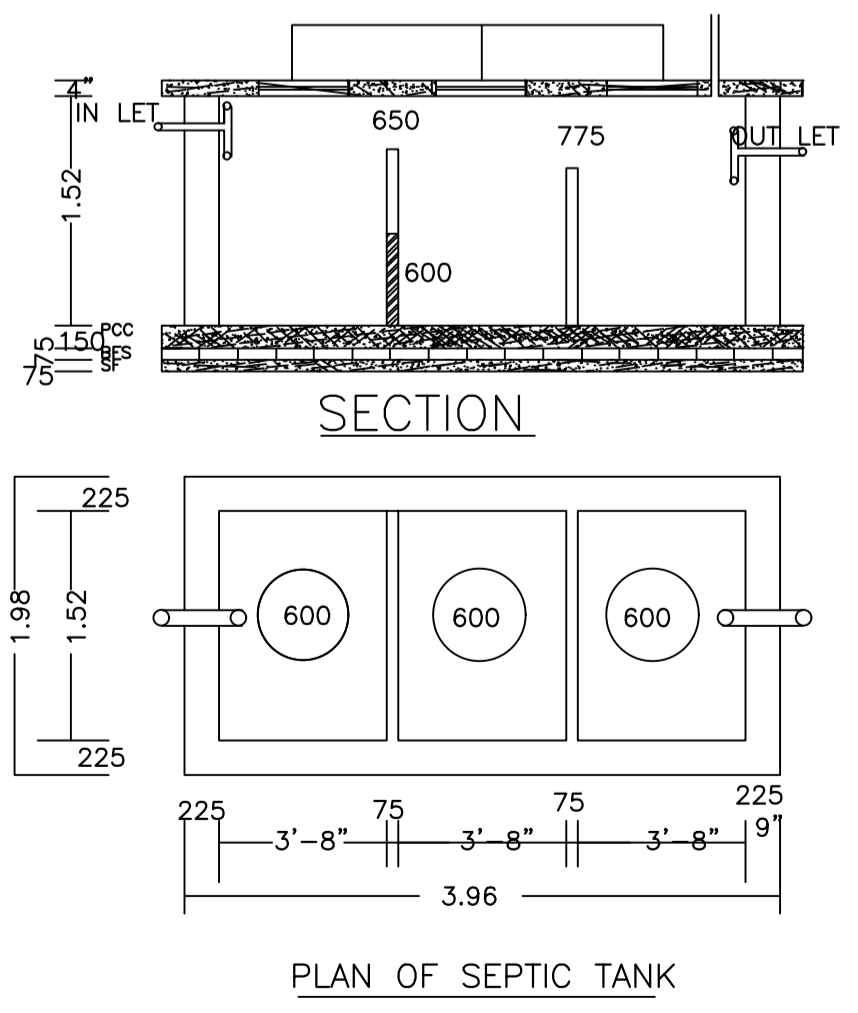
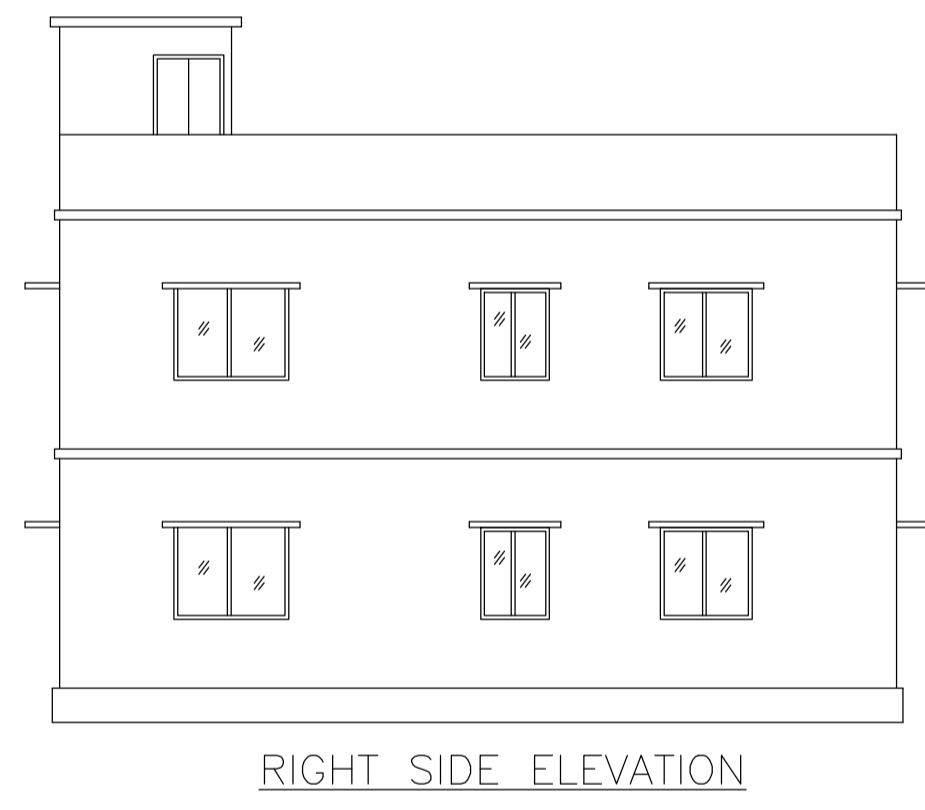
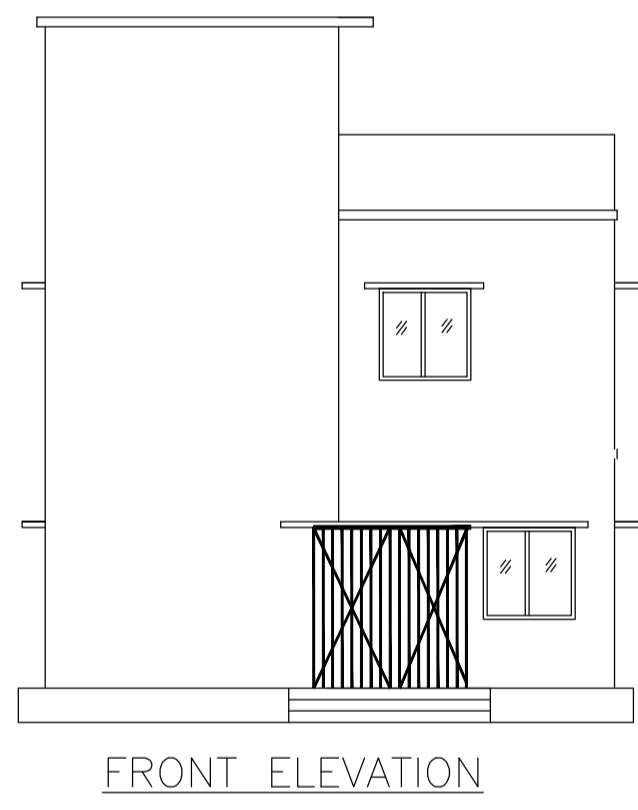
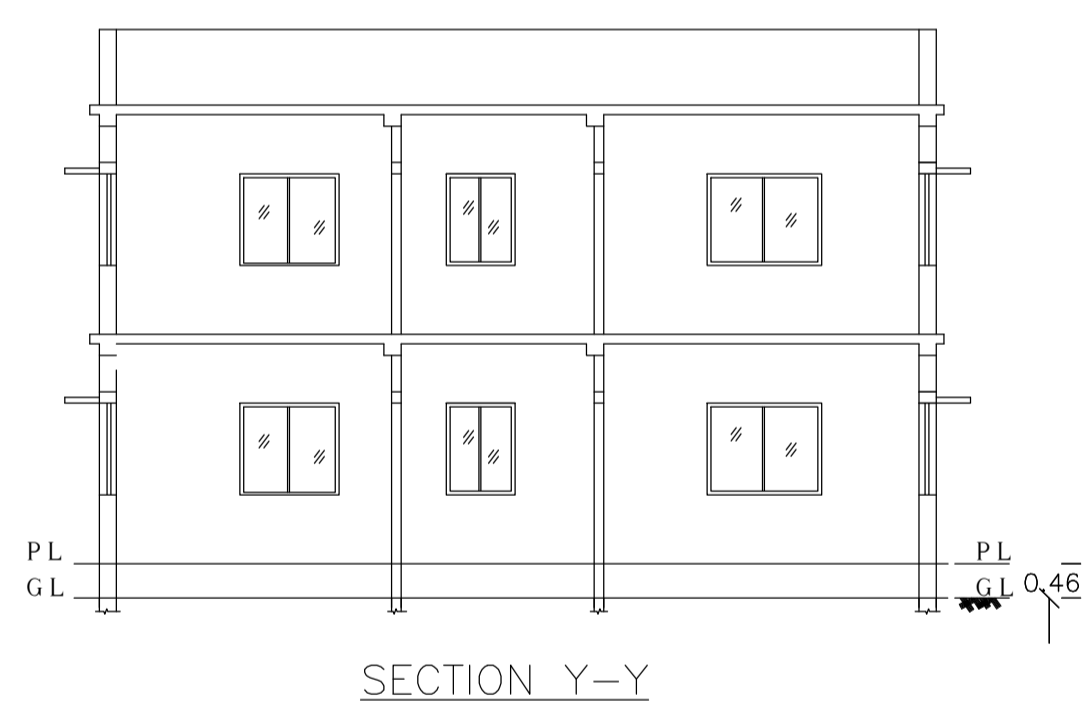
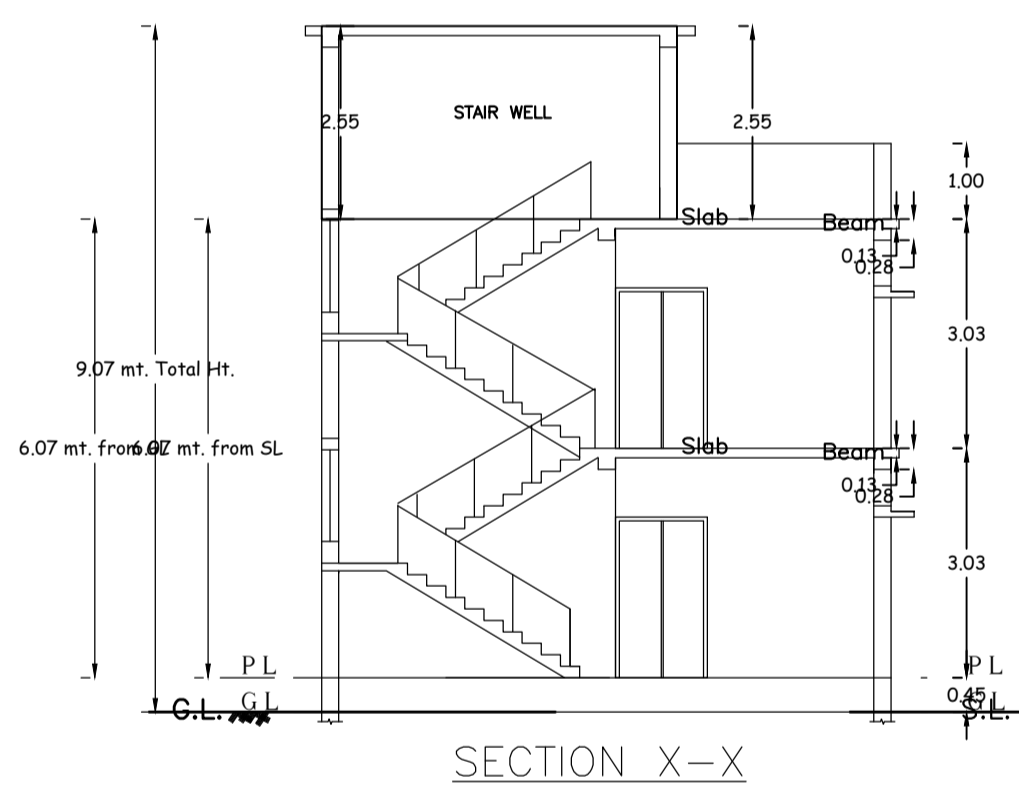
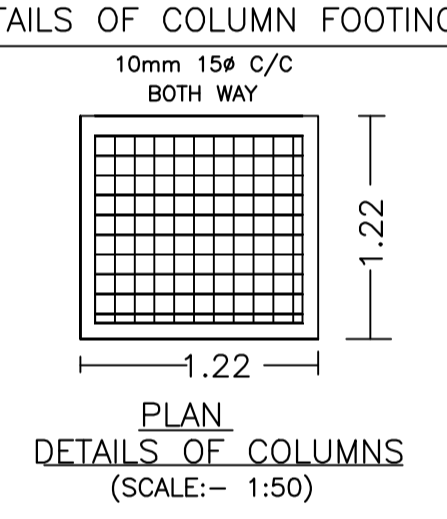
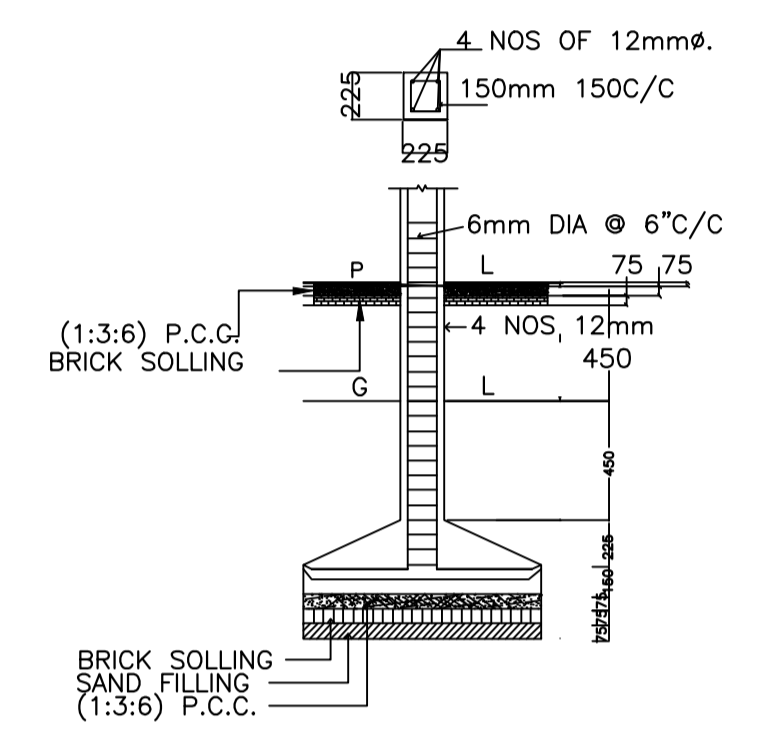
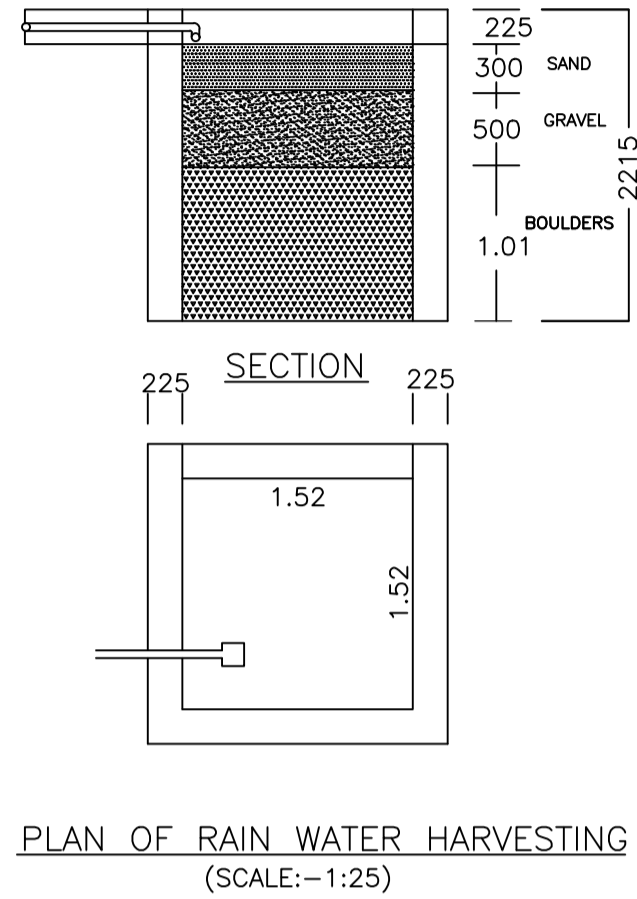
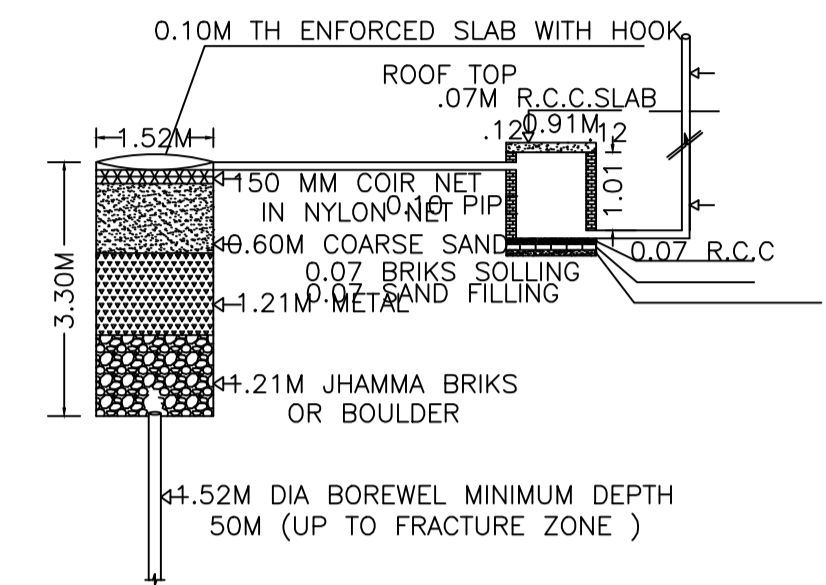
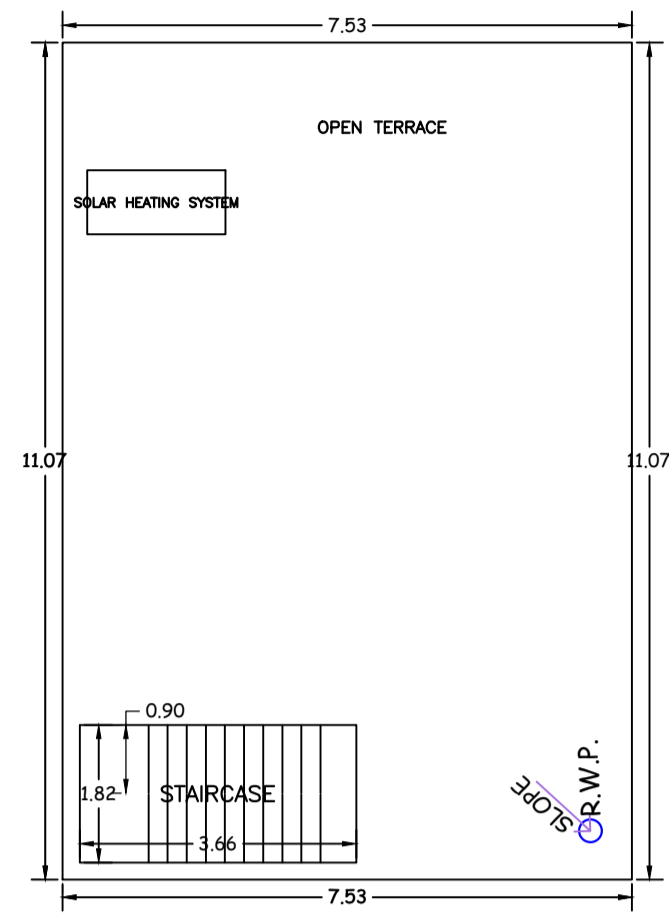
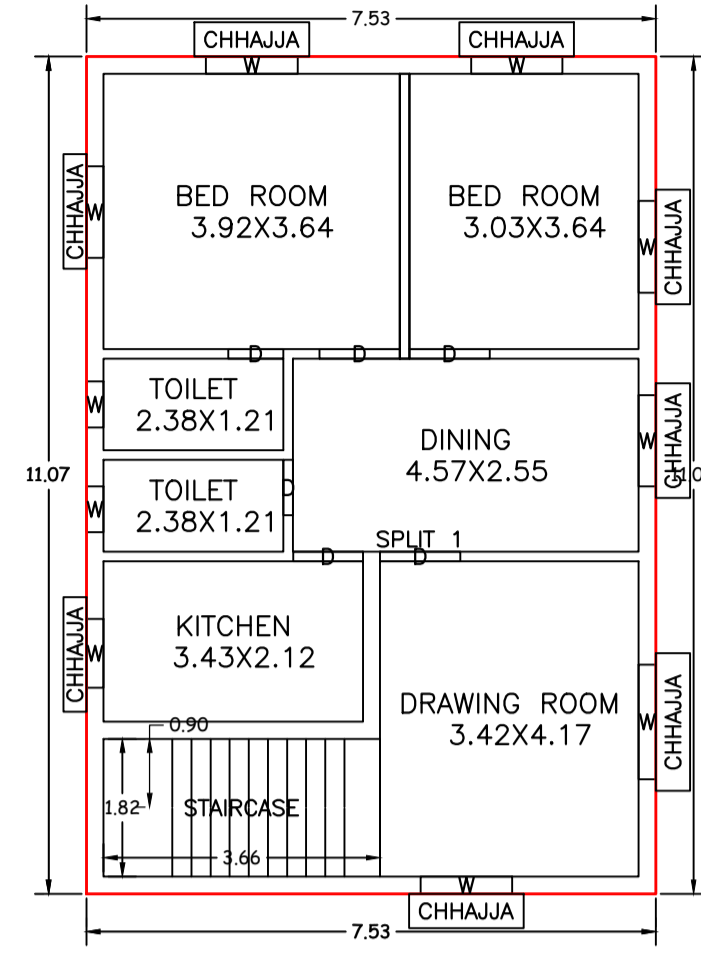
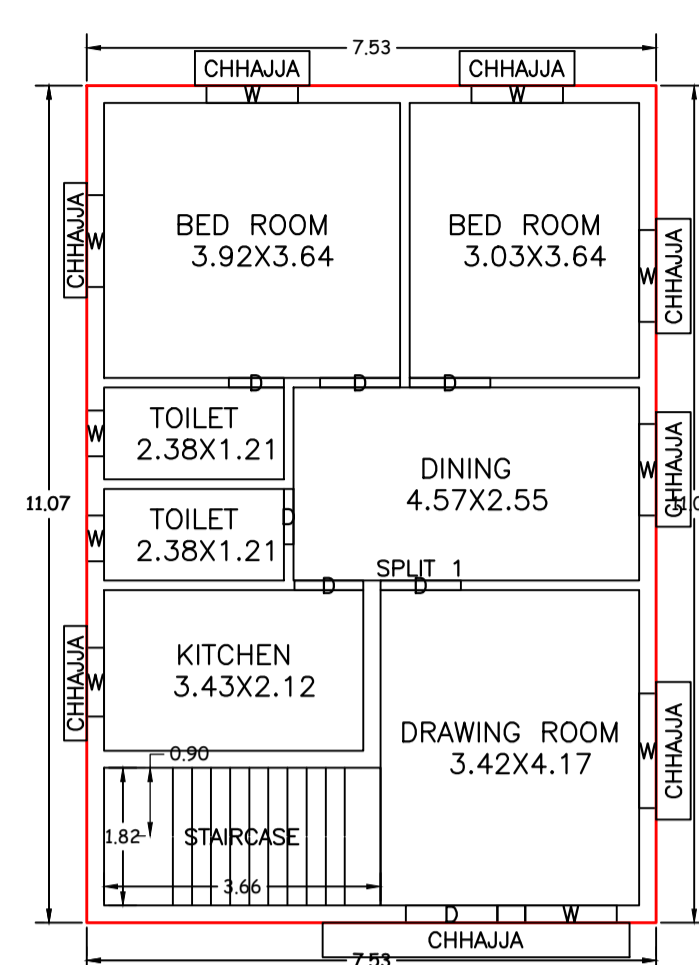

LTP NAME AND SIGNATURE	STRUCTURAL ENG'S NAME AND SIGNATURE	BUILDER NAME AND SIGNATURE	DIGITAL SIGNATURE
DEEPAK KUMAR DMC/ARC/0004/2017			